

CS : COMPUTER SCIENCE AND INFORMATION TECHNOLOGY*Duration:* Three Hours*Maximum Marks:* 100**Read the following instructions carefully.**

1. Do not open the seal of the Question Booklet until you are asked to do so by the invigilator.
2. Take out the **Optical Response Sheet (ORS)** from this Question Booklet **without breaking the seal** and read the instructions printed on the ORS carefully. If you find that either
 - a. The Question Booklet Code printed at the right hand top corner of this page does not match with the Question Booklet Code at the right hand top corner of the **ORS** or
 - b. The Question Paper Code preceding the Registration number on the **ORS** is not **CS**, then exchange the booklet immediately with a new sealed Question Booklet.
3. On the right hand side of the **ORS**, using **ONLY a black ink ballpoint pen**, (i) darken the appropriate bubble under each digit of your registration number and (ii) write your registration number, your name and name of the examination centre and put your signature at the specified location.
4. This Question Booklet contains **20** pages including blank pages for rough work. After you are permitted to open the seal, check all pages and report discrepancies, if any, to the invigilator.
5. There are a total of 65 questions carrying 100 marks. All these questions are of objective type. Each question has only **one** correct answer. Questions must be answered on the left hand side of the **ORS** by darkening the appropriate bubble (marked A, B, C, D) using **ONLY a black ink ballpoint pen** against the question number. **For each question darken the bubble of the correct answer.** More than one answer bubbled against a question will be treated as an incorrect response.
6. Since bubbles darkened by the black ink ballpoint pen **cannot** be erased, candidates should darken the bubbles in the ORS **very carefully**.
7. Questions Q.1 – Q.25 carry 1 mark each. Questions Q.26 – Q.55 carry 2 marks each. The 2 marks questions include two pairs of common data questions and two pairs of linked answer questions. The answer to the second question of the linked answer questions depends on the answer to the first question of the pair. If the first question in the linked pair is wrongly answered or is not attempted, then the answer to the second question in the pair will not be evaluated.
8. Questions Q.56 – Q.65 belong to General Aptitude (GA) section and carry a total of 15 marks. Questions Q.56 – Q.60 carry 1 mark each, and questions Q.61 – Q.65 carry 2 marks each.
9. Questions not attempted will result in zero mark and wrong answers will result in **NEGATIVE** marks. For all 1 mark questions, $\frac{1}{2}$ mark will be deducted for each wrong answer. For all 2 marks questions, $\frac{2}{3}$ mark will be deducted for each wrong answer. However, in the case of the linked answer question pair, there will be negative marks only for wrong answer to the first question and no negative marks for wrong answer to the second question.
10. Calculator is allowed whereas charts, graph sheets or tables are **NOT** allowed in the examination hall.
11. Rough work can be done on the Question Booklet itself. Blank pages are provided at the end of the Question Booklet for rough work.
12. Before the start of the examination, write your name and registration number in the space provided below using a black ink ballpoint pen.

Name									
Registration Number	CS								

Q.1 to Q.25 carry one mark each.

Q.1 The transport layer protocols used for real time multimedia, file transfer, DNS and email, respectively are

- (A) TCP, UDP, UDP and TCP
- (B) UDP, TCP, TCP and UDP
- (C) UDP, TCP, UDP and TCP
- (D) TCP, UDP, TCP and UDP

Q.2 Assume that source S and destination D are connected through two intermediate routers labeled R. Determine how many times each packet has to visit the network layer and the data link layer during a transmission from S to D.

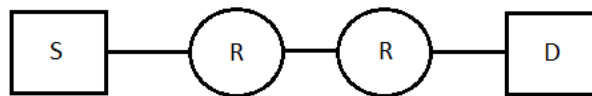

- (A) Network layer – 4 times and Data link layer – 4 times
- (B) Network layer – 4 times and Data link layer – 3 times
- (C) Network layer – 4 times and Data link layer – 6 times
- (D) Network layer – 2 times and Data link layer – 6 times

Q.3 An index is clustered, if

- (A) it is on a set of fields that form a candidate key.
- (B) it is on a set of fields that include the primary key.
- (C) the data records of the file are organized in the same order as the data entries of the index.
- (D) the data records of the file are organized not in the same order as the data entries of the index.

Q.4 Three concurrent processes X, Y, and Z execute three different code segments that access and update certain shared variables. Process X executes the P operation (i.e., wait) on semaphores a, b and c; process Y executes the P operation on semaphores b, c and d; process Z executes the P operation on semaphores c, d, and a before entering the respective code segments. After completing the execution of its code segment, each process invokes the V operation (i.e., signal) on its three semaphores. All semaphores are binary semaphores initialized to one. Which one of the following represents a deadlock-free order of invoking the P operations by the processes?

- (A) X: P(a)P(b)P(c) Y: P(b)P(c)P(d) Z: P(c)P(d)P(a)
- (B) X: P(b)P(a)P(c) Y: P(b)P(c)P(d) Z: P(a)P(c)P(d)
- (C) X: P(b)P(a)P(c) Y: P(c)P(b)P(d) Z: P(a)P(c)P(d)
- (D) X: P(a)P(b)P(c) Y: P(c)P(b)P(d) Z: P(c)P(d)P(a)

Q.5 Which of the following statements is/are **FALSE**?

1. For every non-deterministic Turing machine, there exists an equivalent deterministic Turing machine.
2. Turing recognizable languages are closed under union and complementation.
3. Turing decidable languages are closed under intersection and complementation.
4. Turing recognizable languages are closed under union and intersection.

- (A) 1 and 4 only (B) 1 and 3 only (C) 2 only (D) 3 only

- Q.6 Which of the following statements are **TRUE**?
- The problem of determining whether there exists a cycle in an undirected graph is in P.
 - The problem of determining whether there exists a cycle in an undirected graph is in NP.
 - If a problem A is NP-Complete, there exists a non-deterministic polynomial time algorithm to solve A.
- (A) 1, 2 and 3 (B) 1 and 2 only (C) 2 and 3 only (D) 1 and 3 only
- Q.7 What is the time complexity of Bellman-Ford single-source shortest path algorithm on a complete graph of n vertices?
- (A) $\Theta(n^2)$ (B) $\Theta(n^2 \log n)$ (C) $\Theta(n^3)$ (D) $\Theta(n^3 \log n)$
- Q.8 In a k -way set associative cache, the cache is divided into v sets, each of which consists of k lines. The lines of a set are placed in sequence one after another. The lines in set s are sequenced before the lines in set $(s+1)$. The main memory blocks are numbered 0 onwards. The main memory block numbered j must be mapped to any one of the cache lines from
- (A) $(j \bmod v) * k$ to $(j \bmod v) * k + (k-1)$ (B) $(j \bmod v)$ to $(j \bmod v) + (k-1)$
 (C) $(j \bmod k)$ to $(j \bmod k) + (v-1)$ (D) $(j \bmod k) * v$ to $(j \bmod k) * v + (v-1)$
- Q.9 Which one of the following expressions does **NOT** represent exclusive NOR of x and y ?
- (A) $xy + x'y'$ (B) $x \oplus y'$ (C) $x' \oplus y$ (D) $x' \oplus y'$
- Q.10 Which one of the following functions is continuous at $x = 3$?
- (A) $f(x) = \begin{cases} 2, & \text{if } x = 3 \\ x-1, & \text{if } x > 3 \\ \frac{x+3}{3}, & \text{if } x < 3 \end{cases}$ (B) $f(x) = \begin{cases} 4, & \text{if } x = 3 \\ 8-x, & \text{if } x \neq 3 \end{cases}$
 (C) $f(x) = \begin{cases} x+3, & \text{if } x \leq 3 \\ x-4, & \text{if } x > 3 \end{cases}$ (D) $f(x) = \frac{1}{x^3 - 27}, \text{ if } x \neq 3$
- Q.11 Function f is known at the following points:
- | | | | | | | | | | | | |
|--------|---|------|------|------|------|------|------|------|------|------|------|
| x | 0 | 0.3 | 0.6 | 0.9 | 1.2 | 1.5 | 1.8 | 2.1 | 2.4 | 2.7 | 3.0 |
| $f(x)$ | 0 | 0.09 | 0.36 | 0.81 | 1.44 | 2.25 | 3.24 | 4.41 | 5.76 | 7.29 | 9.00 |
- The value of $\int_0^3 f(x) dx$ computed using the trapezoidal rule is
- (A) 8.983 (B) 9.003 (C) 9.017 (D) 9.045
- Q.12 Which of the following statements is/are **TRUE** for undirected graphs?
- P: Number of odd degree vertices is even.
 Q: Sum of degrees of all vertices is even.
- (A) P only (B) Q only (C) Both P and Q (D) Neither P nor Q
- Q.13 Consider an undirected random graph of eight vertices. The probability that there is an edge between a pair of vertices is $1/2$. What is the expected number of unordered cycles of length three?
- (A) $1/8$ (B) 1 (C) 7 (D) 8

Q.14 A binary operation \oplus on a set of integers is defined as $x \oplus y = x^2 + y^2$. Which one of the following statements is **TRUE** about \oplus ?

- (A) Commutative but not associative (B) Both commutative and associative
(C) Associative but not commutative (D) Neither commutative nor associative

Q.15 Suppose p is the number of cars per minute passing through a certain road junction between 5 PM and 6 PM, and p has a Poisson distribution with mean 3. What is the probability of observing fewer than 3 cars during any given minute in this interval?

- (A) $8/(2e^3)$ (B) $9/(2e^3)$ (C) $17/(2e^3)$ (D) $26/(2e^3)$

Q.16 Which one of the following does **NOT** equal $\begin{vmatrix} 1 & x & x^2 \\ 1 & y & y^2 \\ 1 & z & z^2 \end{vmatrix}$?

(A) $\begin{vmatrix} 1 & x(x+1) & x+1 \\ 1 & y(y+1) & y+1 \\ 1 & z(z+1) & z+1 \end{vmatrix}$

(B) $\begin{vmatrix} 1 & x+1 & x^2+1 \\ 1 & y+1 & y^2+1 \\ 1 & z+1 & z^2+1 \end{vmatrix}$

(C) $\begin{vmatrix} 0 & x-y & x^2-y^2 \\ 0 & y-z & y^2-z^2 \\ 1 & z & z^2 \end{vmatrix}$

(D) $\begin{vmatrix} 2 & x+y & x^2+y^2 \\ 2 & y+z & y^2+z^2 \\ 1 & z & z^2 \end{vmatrix}$

Q.17 The smallest integer that can be represented by an 8-bit number in 2's complement form is

- (A) -256 (B) -128 (C) -127 (D) 0

Q.18 In the following truth table, V = 1 if and only if the input is valid.

Inputs				Outputs		
D ₀	D ₁	D ₂	D ₃	X ₀	X ₁	V
0	0	0	0	x	x	0
1	0	0	0	0	0	1
x	1	0	0	0	1	1
x	x	1	0	1	0	1
x	x	x	1	1	1	1

What function does the truth table represent?

- (A) Priority encoder (B) Decoder
(C) Multiplexer (D) Demultiplexer

Q.19 Which one of the following is the tightest upper bound that represents the number of swaps required to sort n numbers using selection sort?

- (A) $O(\log n)$ (B) $O(n)$ (C) $O(n \log n)$ (D) $O(n^2)$

Q.20 Which one of the following is the tightest upper bound that represents the time complexity of inserting an object into a binary search tree of n nodes?

- (A) $O(1)$ (B) $O(\log n)$ (C) $O(n)$ (D) $O(n \log n)$

- Q.21 Consider the languages $L_1 = \Phi$ and $L_2 = \{a\}$. Which one of the following represents $L_1 L_2^* \cup L_1^*$?
 (A) $\{\epsilon\}$ (B) Φ (C) a^* (D) $\{\epsilon, a\}$
- Q.22 What is the maximum number of reduce moves that can be taken by a bottom-up parser for a grammar with no epsilon- and unit-production (i.e., of type $A \rightarrow \epsilon$ and $A \rightarrow a$) to parse a string with n tokens?
 (A) $n/2$ (B) $n-1$ (C) $2n-1$ (D) 2^n
- Q.23 A scheduling algorithm assigns priority proportional to the waiting time of a process. Every process starts with priority zero (the lowest priority). The scheduler re-evaluates the process priorities every T time units and decides the next process to schedule. Which one of the following is **TRUE** if the processes have no I/O operations and all arrive at time zero?
 (A) This algorithm is equivalent to the first-come-first-serve algorithm.
 (B) This algorithm is equivalent to the round-robin algorithm.
 (C) This algorithm is equivalent to the shortest-job-first algorithm.
 (D) This algorithm is equivalent to the shortest-remaining-time-first algorithm.
- Q.24 Match the problem domains in **GROUP I** with the solution technologies in **GROUP II**.

GROUP I

- (P) Service oriented computing
 (Q) Heterogeneous communicating systems
 (R) Information representation
 (S) Process description

GROUP II

- (1) Interoperability
 (2) BPMN
 (3) Publish-find-bind
 (4) XML

- (A) P-1, Q-2, R-3, S-4 (B) P-3, Q-4, R-2, S-1
 (C) P-3, Q-1, R-4, S-2 (D) P-4, Q-3, R-2, S-1

- Q.25 Using public key cryptography, X adds a digital signature σ to message M , encrypts $\langle M, \sigma \rangle$, and sends it to Y, where it is decrypted. Which one of the following sequences of keys is used for the operations?
 (A) Encryption: X's private key followed by Y's private key; Decryption: X's public key followed by Y's public key
 (B) Encryption: X's private key followed by Y's public key; Decryption: X's public key followed by Y's private key
 (C) Encryption: X's public key followed by Y's private key; Decryption: Y's public key followed by X's private key
 (D) Encryption: X's private key followed by Y's public key; Decryption: Y's private key followed by X's public key

Q.26 to Q.55 carry two marks each.

Q.26 In an IPv4 datagram, the M bit is 0, the value of HLEN is 10, the value of total length is 400 and the fragment offset value is 300. The position of the datagram, the sequence numbers of the first and the last bytes of the payload, respectively are

- (A) Last fragment, 2400 and 2789
- (B) First fragment, 2400 and 2759
- (C) Last fragment, 2400 and 2759
- (D) Middle fragment, 300 and 689

Q.27 The following figure represents access graphs of two modules M1 and M2. The filled circles represent methods and the unfilled circles represent attributes. If method m is moved to module M2 keeping the attributes where they are, what can we say about the average cohesion and coupling between modules in the system of two modules?

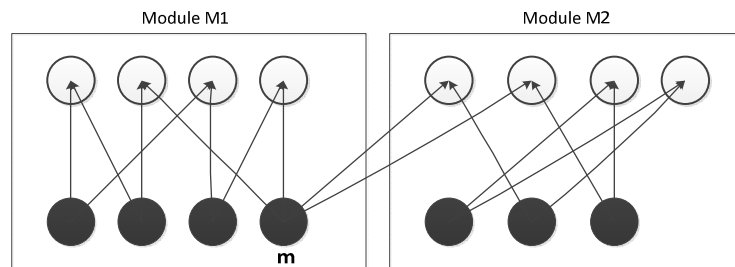

- (A) There is no change.
- (B) Average cohesion goes up but coupling is reduced.
- (C) Average cohesion goes down and coupling also reduces.
- (D) Average cohesion and coupling increase.

- Q.28 A certain computation generates two arrays a and b such that $a[i]=f(i)$ for $0 \leq i < n$ and $b[i]=g(a[i])$ for $0 \leq i < n$. Suppose this computation is decomposed into two concurrent processes X and Y such that X computes the array a and Y computes the array b . The processes employ two binary semaphores R and S , both initialized to zero. The array a is shared by the two processes. The structures of the processes are shown below.

```

Process X:
private i;
for (i=0; i<n; i++) {
    a[i] = f(i);
    ExitX(R, S);
}

Process Y:
private i;
for (i=0; i<n; i++) {
    EntryY(R, S);
    b[i] = g(a[i]);
}

```

Which one of the following represents the **CORRECT** implementations of `ExitX` and `EntryY`?

- (A) `ExitX(R, S) {`
`P(R);`
`V(S);`
`}`
`EntryY(R, S) {`
`P(S);`
`V(R);`
`}`
- (B) `ExitX(R, S) {`
`V(R);`
`V(S);`
`}`
`EntryY(R, S) {`
`P(R);`
`P(S);`
`}`
- (C) `ExitX(R, S) {`
`P(S);`
`V(R);`
`}`
`EntryY(R, S) {`
`V(S);`
`P(R);`
`}`
- (D) `ExitX(R, S) {`
`V(R);`
`P(S);`
`}`
`EntryY(R, S) {`
`V(S);`
`P(R);`
`}`

- Q.29 Consider the following two sets of LR(1) items of an LR(1) grammar.

```

X → c.X, c/d      X → c.X, $
X → .cX, c/d      X → .cX, $
X → .d, c/d        X → .d, $

```

Which of the following statements related to merging of the two sets in the corresponding LALR parser is/are **FALSE**?

1. Cannot be merged since look aheads are different.
2. Can be merged but will result in S-R conflict.
3. Can be merged but will result in R-R conflict.
4. Cannot be merged since *goto* on c will lead to two different sets.

- (A) 1 only (B) 2 only (C) 1 and 4 only (D) 1, 2, 3 and 4

- Q.30 Which of the following is/are undecidable?

1. G is a CFG. Is $L(G) = \Phi$?
2. G is a CFG. Is $L(G) = \Sigma^*$?
3. M is a Turing machine. Is $L(M)$ regular?
4. A is a DFA and N is an NFA. Is $L(A) = L(N)$?

- (A) 3 only (B) 3 and 4 only (C) 1, 2 and 3 only (D) 2 and 3 only

- Q.31 What is the return value of $f(p, p)$, if the value of p is initialized to 5 before the call? Note that the first parameter is passed by reference, whereas the second parameter is passed by value.

```
int f (int &x, int c) {
    c = c - 1;
    if (c==0) return 1;
    x = x + 1;
    return f(x,c) * x;
}
```

- (A) 3024 (B) 6561 (C) 55440 (D) 161051
- Q.32 The preorder traversal sequence of a binary search tree is 30, 20, 10, 15, 25, 23, 39, 35, 42. Which one of the following is the postorder traversal sequence of the same tree?

(A) 10, 20, 15, 23, 25, 35, 42, 39, 30 (B) 15, 10, 25, 23, 20, 42, 35, 39, 30
(C) 15, 20, 10, 23, 25, 42, 35, 39, 30 (D) 15, 10, 23, 25, 20, 35, 42, 39, 30

- Q.33 Consider an instruction pipeline with five stages without any branch prediction: Fetch Instruction (FI), Decode Instruction (DI), Fetch Operand (FO), Execute Instruction (EI) and Write Operand (WO). The stage delays for FI, DI, FO, EI and WO are 5 ns, 7 ns, 10 ns, 8 ns and 6 ns, respectively. There are intermediate storage buffers after each stage and the delay of each buffer is 1 ns. A program consisting of 12 instructions $I_1, I_2, I_3, \dots, I_{12}$ is executed in this pipelined processor. Instruction I_4 is the only branch instruction and its branch target is I_9 . If the branch is taken during the execution of this program, the time (in ns) needed to complete the program is

(A) 132 (B) 165 (C) 176 (D) 328

- Q.34 Consider the following operation along with Enqueue and Dequeue operations on queues, where k is a global parameter.

```
MultiDequeue(Q) {
    m = k
    while (Q is not empty) and (m > 0) {
        Dequeue(Q)
        m = m - 1
    }
}
```

What is the worst case time complexity of a sequence of n queue operations on an initially empty queue?

- (A) $\Theta(n)$ (B) $\Theta(n + k)$ (C) $\Theta(nk)$ (D) $\Theta(n^2)$
- Q.35 A RAM chip has a capacity of 1024 words of 8 bits each ($1K \times 8$). The number of 2×4 decoders with enable line needed to construct a $16K \times 16$ RAM from $1K \times 8$ RAM is

(A) 4 (B) 5 (C) 6 (D) 7

- Q.36 Which one of the following is **NOT** logically equivalent to $\neg \exists x (\forall y (\alpha) \wedge \forall z (\beta))$?

(A) $\forall x (\exists z (\neg \beta) \rightarrow \forall y (\alpha))$ (B) $\forall x (\forall z (\beta) \rightarrow \exists y (\neg \alpha))$
(C) $\forall x (\forall y (\alpha) \rightarrow \exists z (\neg \beta))$ (D) $\forall x (\exists y (\neg \alpha) \rightarrow \exists z (\neg \beta))$

- Q.37 What is the logical translation of the following statement?

“None of my friends are perfect.”

(A) $\exists x (F(x) \wedge \neg P(x))$ (B) $\exists x (\neg F(x) \wedge P(x))$
(C) $\exists x (\neg F(x) \wedge \neg P(x))$ (D) $\neg \exists x (F(x) \wedge P(x))$

- Q.38 The line graph $L(G)$ of a simple graph G is defined as follows:
- There is exactly one vertex $v(e)$ in $L(G)$ for each edge e in G .
 - For any two edges e and e' in G , $L(G)$ has an edge between $v(e)$ and $v(e')$, if and only if e and e' are incident with the same vertex in G .
- Which of the following statements is/are **TRUE**?
- (P) The line graph of a cycle is a cycle.
 (Q) The line graph of a clique is a clique.
 (R) The line graph of a planar graph is planar.
 (S) The line graph of a tree is a tree.
- (A) P only (B) P and R only
 (C) R only (D) P, Q and S only
- Q.39 Consider the following sequence of micro-operations.
- ```

MBR ← PC
MAR ← X
PC ← Y
Memory ← MBR

```
- Which one of the following is a possible operation performed by this sequence?
- (A) Instruction fetch (B) Operand fetch  
 (C) Conditional branch (D) Initiation of interrupt service
- Q.40 Consider a hard disk with 16 recording surfaces (0-15) having 16384 cylinders (0-16383) and each cylinder contains 64 sectors (0-63). Data storage capacity in each sector is 512 bytes. Data are organized cylinder-wise and the addressing format is <cylinder no., surface no., sector no.>. A file of size 42797 KB is stored in the disk and the starting disk location of the file is <1200, 9, 40>. What is the cylinder number of the last sector of the file, if it is stored in a contiguous manner?
- (A) 1281 (B) 1282 (C) 1283 (D) 1284
- Q.41 The number of elements that can be sorted in  $\Theta(\log n)$  time using heap sort is
- (A)  $\Theta(1)$  (B)  $\Theta(\sqrt{\log n})$  (C)  $\Theta\left(\frac{\log n}{\log \log n}\right)$  (D)  $\Theta(\log n)$
- Q.42 Consider the following function:
- ```

int unknown(int n){
    int i, j, k=0;
    for (i=n/2; i<=n; i++)
        for (j=2; j<=n; j=j*2)
            k = k + n/2;
    return (k);
}

```
- The return value of the function is
- (A) $\Theta(n^2)$ (B) $\Theta(n^2 \log n)$ (C) $\Theta(n^3)$ (D) $\Theta(n^3 \log n)$
- Q.43 Consider the following languages.
- $$L_1 = \{0^p 1^q 0^r \mid p, q, r \geq 0\}$$
- $$L_2 = \{0^p 1^q 0^r \mid p, q, r \geq 0, p \neq r\}$$
- Which one of the following statements is **FALSE**?
- (A) L_2 is context-free.
 (B) $L_1 \cap L_2$ is context-free.
 (C) Complement of L_2 is recursive.
 (D) Complement of L_1 is context-free but not regular.

Q.44 Consider the DFA A given below.

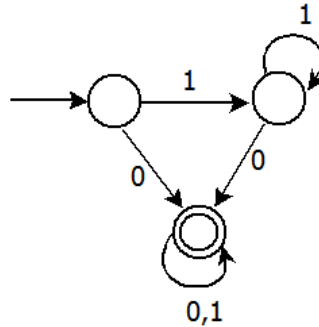

Which of the following are **FALSE**?

1. Complement of $L(A)$ is context-free.
2. $L(A) = L((11^*0+0)(0+1)^*0^*1^*)$
3. For the language accepted by A , A is the minimal DFA.
4. A accepts all strings over $\{0, 1\}$ of length at least 2.

(A) 1 and 3 only (B) 2 and 4 only (C) 2 and 3 only (D) 3 and 4 only

Q.45 A shared variable x , initialized to zero, is operated on by four concurrent processes W, X, Y, Z as follows. Each of the processes W and X reads x from memory, increments by one, stores it to memory, and then terminates. Each of the processes Y and Z reads x from memory, decrements by two, stores it to memory, and then terminates. Each process before reading x invokes the P operation (i.e., *wait*) on a counting semaphore S and invokes the V operation (i.e., *signal*) on the semaphore S after storing x to memory. Semaphore S is initialized to two. What is the maximum possible value of x after all processes complete execution?

(A) -2 (B) -1 (C) 1 (D) 2

Q.46 Consider the following relational schema.

Students(rollno: integer, sname: string)
 Courses(courseno: integer, cname: string)
 Registration(rollno: integer, courseno: integer, percent: real)

Which of the following queries are equivalent to this query in English?

“Find the distinct names of all students who score more than 90% in the course numbered 107”

- (I) $\text{SELECT DISTINCT } S.\text{sname}$
 $\text{FROM Students as } S, \text{Registration as } R$
 $\text{WHERE } R.\text{rollno}=S.\text{rollno AND } R.\text{courseno}=107 \text{ AND } R.\text{percent} > 90$
- (II) $\prod_{\text{sname}}(\sigma_{\text{courseno}=107 \wedge \text{percent}>90}(\text{Registration} \bowtie \text{Students}))$
- (III) $\{T \mid \exists S \in \text{Students}, \exists R \in \text{Registration} (S.\text{rollno}=R.\text{rollno} \wedge$
 $R.\text{courseno}=107 \wedge R.\text{percent}>90 \wedge T.\text{sname}=S.\text{sname})\}$
- (IV) $\{\langle S_N \rangle \mid \exists S_R \exists R_P (\langle S_R, S_N \rangle \in \text{Students} \wedge \langle S_R, 107, R_P \rangle \in \text{Registration} \wedge R_P > 90)\}$

(A) I, II, III and IV (B) I, II and III only
 (C) I, II and IV only (D) II, III and IV only

Q.47 Determine the maximum length of the cable (in km) for transmitting data at a rate of 500 Mbps in an Ethernet LAN with frames of size 10,000 bits. Assume the signal speed in the cable to be 2,00,000 km/s.

(A) 1 (B) 2 (C) 2.5 (D) 5

Common Data Questions

Common Data for Questions 48 and 49:

The procedure given below is required to find and replace certain characters inside an input character string supplied in array A. The characters to be replaced are supplied in array `oldc`, while their respective replacement characters are supplied in array `newc`. Array A has a fixed length of five characters, while arrays `oldc` and `newc` contain three characters each. However, the procedure is flawed.

```
void find_and_replace (char *A, char *oldc, char *newc) {
    for (int i=0; i<5; i++)
        for (int j=0; j<3; j++)
            if (A[i] == oldc[j]) A[i] = newc[j];
}
```

The procedure is tested with the following four test cases.

- (1) `oldc = "abc"`, `newc = "dab"` (2) `oldc = "cde"`, `newc = "bcd"`
(3) `oldc = "bca"`, `newc = "cda"` (4) `oldc = "abc"`, `newc = "bac"`

Q.48 If array A is made to hold the string "abcde", which of the above four test cases will be successful in exposing the flaw in this procedure?

- (A) None (B) 2 only
(C) 3 and 4 only (D) 4 only

Q.49 The tester now tests the program on all input strings of length five consisting of characters 'a', 'b', 'c', 'd' and 'e' with duplicates allowed. If the tester carries out this testing with the four test cases given above, how many test cases will be able to capture the flaw?

- (A) Only one (B) Only two (C) Only three (D) All four

Common Data for Questions 50 and 51:

The following code segment is executed on a processor which allows only register operands in its instructions. Each instruction can have at most two source operands and one destination operand. Assume that all variables are dead after this code segment.

```
c = a + b;
d = c * a;
e = c + a;
x = c * c;
if (x > a) {
    y = a * a;
}
else {
    d = d * d;
    e = e * e;
}
```

Q.50 What is the minimum number of registers needed in the instruction set architecture of the processor to compile this code segment without any spill to memory? Do not apply any optimization other than optimizing register allocation.

- (A) 3 (B) 4 (C) 5 (D) 6

Q.51 Suppose the instruction set architecture of the processor has only two registers. The only allowed compiler optimization is code motion, which moves statements from one place to another while preserving correctness. What is the minimum number of spills to memory in the compiled code?

- (A) 0 (B) 1 (C) 2 (D) 3

Linked Answer Questions

Statement for Linked Answer Questions 52 and 53:

Relation R has eight attributes $ABCDEFGH$. Fields of R contain only atomic values.

$F = \{CH \rightarrow G, A \rightarrow BC, B \rightarrow CFH, E \rightarrow A, F \rightarrow EG\}$ is a set of functional dependencies (FDs) so that F^+ is exactly the set of FDs that hold for R .

Q.52 How many candidate keys does the relation R have?

- (A) 3 (B) 4 (C) 5 (D) 6

Q.53 The relation R is

- (A) in 1NF, but not in 2NF. (B) in 2NF, but not in 3NF.
(C) in 3NF, but not in BCNF. (D) in BCNF.

Statement for Linked Answer Questions 54 and 55:

A computer uses 46-bit virtual address, 32-bit physical address, and a three-level paged page table organization. The page table base register stores the base address of the first-level table (T_1), which occupies exactly one page. Each entry of T_1 stores the base address of a page of the second-level table (T_2). Each entry of T_2 stores the base address of a page of the third-level table (T_3). Each entry of T_3 stores a page table entry (PTE). The PTE is 32 bits in size. The processor used in the computer has a 1 MB 16-way set associative virtually indexed physically tagged cache. The cache block size is 64 bytes.

Q.54 What is the size of a page in KB in this computer?

- (A) 2 (B) 4 (C) 8 (D) 16

Q.55 What is the minimum number of page colours needed to guarantee that no two synonyms map to different sets in the processor cache of this computer?

- (A) 2 (B) 4 (C) 8 (D) 16

General Aptitude (GA) Questions**Q.56 to Q.60 carry one mark each.**

Q.56 Choose the grammatically **INCORRECT** sentence:

- (A) He is of Asian origin.
- (B) They belonged to Africa.
- (C) She is an European.
- (D) They migrated from India to Australia.

Q.57 What will be the maximum sum of 44, 42, 40, ?

- (A) 502 (B) 504 (C) 506 (D) 500

Q.58 Were you a bird, you _____ in the sky.

- (A) would fly (B) shall fly (C) should fly (D) shall have flown

Q.59 Which one of the following options is the closest in meaning to the word given below?

Nadir

- (A) Highest (B) Lowest (C) Medium (D) Integration

Q.60 Complete the sentence:

Universalism is to particularism as diffuseness is to _____.

- (A) specificity (B) neutrality (C) generality (D) adaptation

Q.61 to Q.65 carry two marks each.

Q.61 The current erection cost of a structure is Rs. 13,200. If the labour wages per day increase by $\frac{1}{5}$ of the current wages and the working hours decrease by $\frac{1}{24}$ of the current period, then the new cost of erection in Rs. is

- (A) 16,500 (B) 15,180 (C) 11,000 (D) 10,120

Q.62 After several defeats in wars, Robert Bruce went in exile and wanted to commit suicide. Just before committing suicide, he came across a spider attempting tirelessly to have its net. Time and again, the spider failed but that did not deter it to refrain from making attempts. Such attempts by the spider made Bruce curious. Thus, Bruce started observing the near-impossible goal of the spider to have the net. Ultimately, the spider succeeded in having its net despite several failures. Such act of the spider encouraged Bruce not to commit suicide. And then, Bruce went back again and won many a battle, and the rest is history.

Which one of the following assertions is best supported by the above information?

- (A) Failure is the pillar of success.
- (B) Honesty is the best policy.
- (C) Life begins and ends with adventures.
- (D) No adversity justifies giving up hope.

Q.63 A tourist covers half of his journey by train at 60 km/h, half of the remainder by bus at 30 km/h and the rest by cycle at 10 km/h. The average speed of the tourist in km/h during his entire journey is

- (A) 36 (B) 30 (C) 24 (D) 18

Q.64 Find the sum of the expression

$$\frac{1}{\sqrt{1}+\sqrt{2}} + \frac{1}{\sqrt{2}+\sqrt{3}} + \frac{1}{\sqrt{3}+\sqrt{4}} + \dots + \frac{1}{\sqrt{80}+\sqrt{81}}$$

(A) 7
(C) 9

(B) 8
(D) 10

Q.65 Out of all the 2-digit integers between 1 and 100, a 2-digit number has to be selected at random. What is the probability that the selected number is not divisible by 7?

(A) 13/90

(B) 12/90

(C) 78/90

(D) 77/90

END OF THE QUESTION PAPER

Space for Rough Work

Space for Rough Work

Space for Rough Work

Space for Rough Work

Space for Rough Work

Space for Rough Work