

BITSAT

Engineering Entrance Exam Solved Paper 2009

MATHEMATICS

1. $x \in R : \frac{2x-1}{x^3+4x^2+3x} \in R$ Equals
- (a) $R - \{0\}$
 - (b) $R - \{0, 1, 3\}$
 - (c) $R - \{0, -1, -3\}$
 - (d) $R - \{0, -1, -3, \frac{1}{2}\}$
2. The number of subsets of $\{1, 2, 3, \dots, 9\}$ containing at least one odd number is -
- (a) 324
 - (b) 396
 - (c) 496
 - (d) 512
3. The coefficient of x^{24} in the expansion of $(1 + x^2)^{12}(1 + x^{12})(1 + x^{24})$ is
- (a) ${}^{12}C_6$
 - (b) ${}^{12}C_6 + 2$
 - (c) ${}^{12}C_6 + 4$
 - (d) ${}^{12}C_6 + 6$

4. For $|x| < 1$, the constant term in the expansion of $\frac{1}{x-1} \frac{1}{x-2}$ is

- (a) 2
- (b) 1
- (c) 0
- (d) $-\frac{1}{2}$

5. The roots of

$$(x - a)(x - a - 1) + (x - a - 1)(x - a - 2) + (x - a)(x - a - 2) = 0,$$

$a \in \mathbb{R}$ are always

- (a) Equal
- (b) Imaginary
- (c) real and distinct
- (d) rational and equal

6. Let $f(x) = x^2 + ax + b$, where $a, b \in \mathbb{R}$. If $f(x) = 0$ has all its roots imaginary, then the roots of $f(x) + f'(x) + f''(x) = 0$ are

- (a) Real and distinct
- (b) Imaginary
- (c) Equal
- (d) Rational and equal

7. If one of the roots of $\begin{vmatrix} 3 & 5 & x \\ 7 & x & 7 \\ x & 5 & 3 \end{vmatrix} = 0$ is -10 , then the other roots are

- (a) 3, 7
- (b) 4, 7
- (c) 3, 9
- (d) 3, 4

8. If x, y, z are all positive and are the p th, q th and r th terms of a geometric progression respectively, then the value of the determinant

$$\begin{vmatrix} \log x & p & 1 \\ \log y & q & 1 \\ \log z & r & 1 \end{vmatrix} \text{ equals}$$

- (a) $\log xyz$
- (b) $(p - 1)(q - 1)(r - 1)$
- (c) pqr
- (d) 0

9. If $\begin{vmatrix} 1 & -1 & x \\ 1 & x & 1 \\ x & -1 & 1 \end{vmatrix}$ has no inverse, then the real value of x is

- (a) 2
- (b) 3
- (c) 0
- (d) 1

10. The locus of z satisfying the inequality $\frac{z+2i}{2z+i} < 1$, where $z = x + iy$, is

- (a) $x^2 + y^2 < 1$

- (b) $x^2 - y^2 < 1$
- (c) $x^2 + y^2 > 1$
- (d) $2x^2 + 3y^2 < 1$

11. The period of $\sin^4 x + \cos^4 x$ is

- (a) $\frac{\pi^4}{2}$
- (b) $\frac{\pi^2}{2}$
- (c) $\frac{\pi}{4}$
- (d) $\frac{\pi}{2}$

12. $\frac{\cos x}{\cos x - 2y} = \lambda \Rightarrow \tan x - y \tan y$ is equal to

- (a) $\frac{1+\lambda}{1-\lambda}$
- (b) $\frac{1+\lambda}{1+\lambda}$
- (c) $\frac{\lambda}{1+\lambda}$
- (d) $\frac{\lambda}{1-\lambda}$

13. $\cos A \cos 2A \cos 4A \dots \cos 2^{n-1} A$ equals

- (a) $\frac{\sin 2^n A}{2^n \sin A}$
- (b) $\frac{2^n \sin 2^n A}{\sin A}$
- (c) $\frac{2^n \sin A}{\sin 2^n A}$

(d) $\frac{\sin A}{2^n \sin 2^n A}$

14. If $3 \cos x \neq -2 \sin x$, then the general solution of $\sin^2 x - \cos 2x = 2 - \sin 2x$ is

(a) $n\pi + (-1)^n \frac{\pi}{2}, n \in \mathbb{Z}$

(b) $\frac{n\pi}{2}, n \in \mathbb{Z}$

(c) $4n \pm 1 \frac{\pi}{2}, n \in \mathbb{Z}$

(d) $2n - 1 \pi, n \in \mathbb{Z}$

15. In a ΔABC

$\frac{a+b+c}{4b^2c^2} \frac{b+c-a}{4b^2c^2} \frac{c+a-b}{4b^2c^2} \frac{a+b-c}{4b^2c^2}$ equals

(a) $\cos^2 A$

(b) $\cos^2 B$

(c) $\sin^2 A$

(d) $\sin^2 B$

16. P is a point on the segment joining the feet of two vertical poles of heights a and b. The angles of elevation of the tops of the poles from P are 45° each. Then, the square of the distance between the tops of the poles is

(a) $\frac{a^2 + b^2}{2}$

(b) $a^2 + b^2$

(c) $2(a^2 + b^2)$

(d) $4(a^2 + b^2)$

17. In a quadrilateral ABCD, the point P divides DC in the ratio 1:2 and Q is the mid point of AG. If $AB + 2AD + BC - 2DC = k PQ$, then k is equal to

- (a) - 6
- (b) - 4
- (c) 6
- (d) 4

18. If m_1, m_2, m_3 and m_4 are respectively the magnitudes of the vectors

$$a_1 = 2i - j + k, a_2 = 3i - 4j - 4k,$$

$$a_3 = i + j - k \text{ and } a_4 = -i + 3j + k,$$

then the correct order of m_1, m_2, m_3 and m_4 is

- (a) $m_3 < m_1 < m_4 < m_2$
 - (b) $m_3 < m_1 < m_2 < m_4$
 - (c) $m_3 < m_4 < m_1 < m_2$
 - (d) $m_3 < m_4 < m_2 < m_1$
19. The volume of the tetrahedron having the edges $i + 2j - k, i + j + k, i - j + \lambda k$ as coterminous, is $\frac{2}{3}$ cubic unit. Then λ equals
- (a) 1
 - (b) 2
 - (c) 3
 - (d) 4

20. If A and B are events of a random experiment such that $P(A \cup B) = \frac{4}{5}$, $P(A \cup \bar{B}) = \frac{7}{10}$ and $P(B) = \frac{2}{5}$, then $P(A)$ equals

(a) $\frac{9}{10}$

(b) $\frac{8}{10}$

(c) $\frac{7}{10}$

(d) $\frac{3}{5}$

21. If X is a binomial variate with the range $\{0, 1, 2, 3, 4, 5, 6\}$ and $P(X = 2) = 4P(X = 4)$, then the parameter p of X is

(a) $\frac{1}{3}$

(b) $\frac{1}{2}$

(c) $\frac{2}{3}$

(d) $\frac{3}{4}$

22. The area (in square unit) of the circle which touches the lines $4x + 3y = 15$ and $4x + 3y = 5$ is

(a) 4π

(b) 3π

(c) 2π

(d) π

23. The point on the line $3x + 4y = 5$ which is equidistant from (1, 1) and (4, 1) is

- 2) and (3, 4) is
- (a) (7, -4)
 - (b) (15, -10)
 - (c) (1/7, 8/7)
 - (d) (0, 5/4)
24. The equation of the straight line perpendicular to the straight line $3x + 2y = 0$ and passing through the point of intersection of the lines $x + 3y - 1 = 0$ and $x - 2y + 4 = 0$ is
- (a) $2x - 3y + 1 = 0$
 - (b) $2x - 3y + 3 = 0$
 - (c) $2x - 3y + 5 = 0$
 - (d) $2x - 3y + 7 = 0$
25. The value of λ with $|\lambda| < 16$ such that $2x^2 - 10xy + 12y^2 + 5x + \lambda y - 3 = 0$ represents a pair of straight lines, is
- (a) -10
 - (b) -9
 - (c) 10
 - (d) 9
26. The area (in square unit) of the triangle formed by $x + y + 1 = 0$ and the pair of straight lines $x^2 - 3xy + 2y^2 = 0$ is
- (a) 7/12
 - (b) 5/12
 - (c) 1/12

(d) $1/6$

27. The pairs of straight lines $x^2 - 3xy + 2y^2 = 0$ and $x^2 - 3xy + 2y^2 + x - 2 = 0$ form a

- (a) Square but not rhombus
- (b) Rhombus
- (c) Parallelogram
- (d) Rectangle but not a square

28. The equations of the circle which pass through the origin and makes intercepts of lengths 4 and 8 on the x and y-axes respectively are

- (a) $x^2 + y^2 \pm 4x \pm 8y = 0$
- (b) $x^2 + y^2 \pm 2x \pm 4y = 0$
- (c) $x^2 + y^2 \pm 8x \pm 16y = 0$
- (d) $x^2 + y^2 \pm x \pm y = 0$

29. The locus of centre of a circle which passes through the origin and cuts off a length of 4 unit from the line $x = 3$ is

- (a) $y^2 + 6x = 0$
- (b) $y^2 + 6x = 13$
- (c) $y^2 + 6x = 10$
- (d) $x^2 + 6y = 13$

30. The point $(3, -4)$ lies on both the circles $x^2 + y^2 - 2x + 8y + 13 = 0$ and $x^2 + y^2 - 4x + 6y + 11 = 0$ Then, the angle between the circles is -

- (a) 60°
- (b) $\tan^{-1} \frac{1}{2}$
- (c) $\tan^{-1} \frac{3}{5}$
- (d) 135°
31. The equation of the circle which passes through the origin and cuts orthogonally each of the circles $x^2 + y^2 - 6x + 8 = 0$ and $x^2 + y^2 - 2x - 2y = T$ is
- (a) $3x^2 + 3y^2 - 8x - 13y = 0$
- (b) $3x^2 + 3y^2 - 8x + 29y = 0$
- (c) $3x^2 + 3y^2 + 8x + 29y = 0$
- (d) $3x^2 + 3y^2 - 8x - 29y = 0$
32. The number of normals drawn to the parabola $y^2 = 4x$ from the point $(1, 0)$ is
- (a) 0
- (b) 1
- (c) 2
- (d) 3
33. If the circle $x^2 + y^2 = a^2$ intersects the hyperbola $xy = c^2$ in four points (x_i, y_i) , for $i = 1, 2, 3$ and 4 , then $y_1 + y_2 + y_3 + y_4$ equals
- (a) 0
- (b) c
- (c) a

(d) c^4

34. The mid point of the chord $4x - 3y = 5$ of the hyperbola $2x^2 - 3y^2 - 12$ is

(a) $0, -\frac{5}{3}$

(b) $2, 1$

(c) $\frac{5}{4}, 0$

(d) $\frac{11}{4}, 2$

35. If a line in the space makes angle α , β and γ with the coordinate axes, then

$\cos 2\alpha + \cos 2\beta + \cos 2\gamma + \sin^2 \alpha + \sin^2 \beta + \sin^2 \gamma$ equals

(a) -1

(b) 0

(c) 1

(d) 2

36. The image of the point $(3, 2, 1)$ in the plane $2x - y + 3z = 7$ is

(a) $(1, 2, 3)$

(b) $(2, 3, 1)$

(c) $(3, 2, 1)$

(d) $(2, 1, 3)$

37. $\lim_{x \rightarrow \infty} \frac{x+5}{x+2}^{x+3}$ equals

- (a) e
- (b) e^2
- (c) e^3
- (d) e^5

38. If $f: \mathbb{R} \rightarrow \mathbb{R}$ is defined by

$f(x) = \begin{cases} \frac{2 \sin x - \sin 2x}{2x \cos x}, & \text{if } x \neq 0 \\ a, & \text{if } x = 0 \end{cases}$, then the value of a so that f is continuous at 0 is

- (a) 2
- (b) 1
- (c) -1
- (d) 0

39. $x = \frac{1-\bar{y}}{1+\bar{y}} \Rightarrow \frac{dy}{dx}$ is equal to

- (a) $\frac{4}{x+1}^2$
- (b) $\frac{4x-1}{1+x}^3$
- (c) $\frac{x-1}{1+x}^3$
- (d) $\frac{4}{x+1}^3$

40. $\frac{d}{dx} a \tan^{-1} x + b \log \frac{x-1}{x+1} = \frac{1}{x^2-1} \Rightarrow a - 2b$ is equal to

- (a) 1
- (b) -1
- (c) 0
- (d) 2

41. $y = e^{a \sin^{-1} x} \Rightarrow (1 - x^2) y_{n+2} - (2n + 1) xy_{n+1}$ is equal to

- (a) $-(n^2 + a^2)y_n$
- (b) $(n^2 - a^2)y_n$
- (c) $(n^2 + a^2) y_n$
- (d) $-(n^2 - a^2) y_n$

42. The function $f(x) = x^3 + ax^2 + bx + c, a^2 \leq 3b$ has

- (a) one maximum value
- (b) one minimum value
- (c) no extreme value
- (d) one maximum and one minimum value

43. $\int \frac{2 - \sin 2x}{1 - \cos 2x} e^x dx$ is equal to

- (a) $-e^x \cot x + c$
- (b) $e^x \cot x + c$
- (c) $2e^x \cot x + c$
- (d) $-2e^x \cot x + c$

44. $\int_0^{\pi} \frac{1}{1 + \sin x} dx$ is equal to

- (a) 1
- (b) 2
- (c) -1
- (d) -2

45. The solution of the differential equation $\frac{dy}{dx} = \sin x + y \tan x + y - 1$ is

- (a) $\operatorname{cosec}(x + y) + \tan(x + y) = x + c$
- (b) $x + \operatorname{cosec}(x + y) = c$
- (c) $x + \tan(x + y) = c$
- (d) $x + \sec(x + y) = c$

Physics

46. When a wave traverses a medium the displacement of a particle located at x at a time is given by $y = a \sin(bt - cx)$, where a , b and c are constants of the wave, which of the following is a quantity with dimensions?

- (a) $\frac{y}{a}$
- (b) bt
- (c) cx
- (d) $\frac{b}{c}$

47. A body is projected vertically upwards at time $t = 0$ and it is seen at a height H at time t_1 and t_2 second during its flight. The maximum height attained is (g is acceleration due to gravity)

(a) $\frac{g t_2 - t_1^2}{8}$

(b) $\frac{g t_1 + t_2^2}{4}$

(c) $\frac{g t_1 + t_2^2}{8}$

(d) $\frac{g t_2 - t_1^2}{4}$

48. A particle is projected up from a point at an angle θ with the horizontal direction. At any time t , if P is the linear momentum, y is the vertical displacement, x is horizontal displacement, the graph among the following which does not represent the variation of kinetic energy KE of the particle is

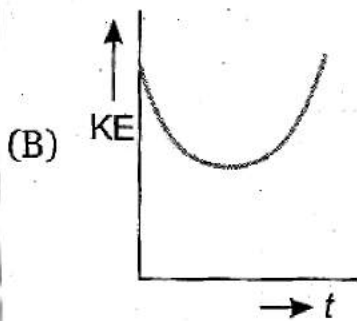
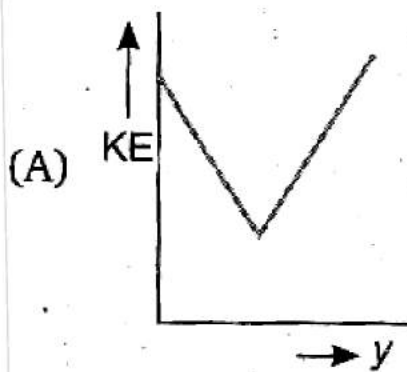

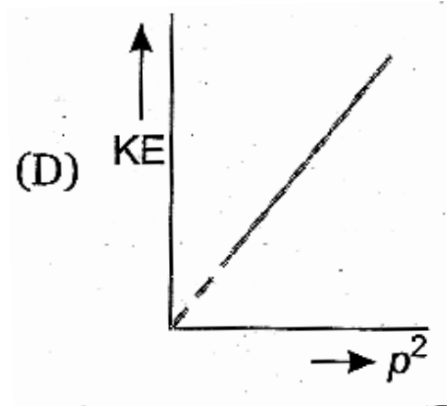
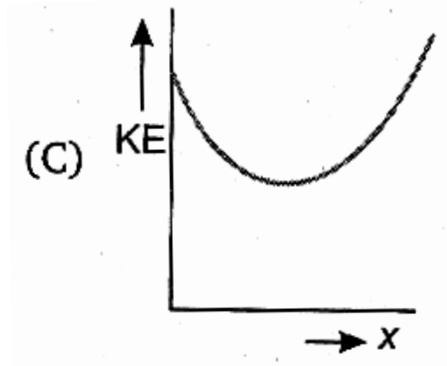

- (a) graph (A)
- (b) graph (B)
- (c) graph (C)
- (d) graph (D)

49. A motor of power P_0 is used to deliver water at a certain rate through a given horizontal pipe. To increase the rate of flow of water through the same pipe n times, the power of the motor is increased to P_1 . The ratio of P_1 to P_0 is

- (a) $n: 1$
- (b) $n^2: 1$
- (c) $n^3: 1$

(d) $n^4: 1$

50. A body of mass 5 kg makes an elastic collision with another body at rest and continues to move in the original direction after collision with a velocity equal to 1/10th of its original velocity. Then the mass of the second body is

(a) 4.09 kg

(b) 0.5 kg

(c) 5 kg

(d) 5.09 kg

51. A particle of mass 4 m explodes into three pieces, of masses m, m and 2 m. The equal masses move along X-axis and Y-axis with velocities 4 ms^{-1} and 6 ms^{-1} respectively. The magnitude of the velocity of the heavier mass is

(a) $\sqrt{17} \text{ ms}^{-1}$

(b) $2\sqrt{13} \text{ ms}^{-1}$

(c) $\sqrt{13} \text{ ms}^{-1}$

(d) $\frac{\sqrt{13}}{2} \text{ ms}^{-1}$

52. A body is projected vertically upwards from the surface of the earth with a velocity equal to half the escape velocity. If R is the radius of the earth, maximum height attained by the body from the surface of the earth is

(a) $R/6$

(b) $R/3$

(c) $2R/3$

(d) R

53. The displacement of a particle executing SHM is given by

$$y = 5 \sin 4t + \frac{\pi}{3} .$$

If T is the time period and the mass of the particle is 2 g, the kinetic energy of the particle when $t = \frac{T}{4}$ is given by

(a) 0.4 J

(b) 0.5 J

(c) 3 J

(d) 0.3 J

54. If the ratio of lengths, radii and Young's modulus of steel and brass wires shown in the figure are a, b and c respectively, the ratio between the increase in lengths of brass and steel wires would be



(a) $\frac{b^2 a}{2c}$

(b) $\frac{bc}{2a^2}$

(c) $\frac{ba^2}{2c}$

(d) $\frac{a}{24\pi Tr^2}$

55. A soap bubble of radius r is blown up to form a bubble of radius $2r$ under isothermal conditions. If T is the surface tension of soap solution, the energy spent in the blowing

- (a) $3\pi Tr^2$
- (b) $6\pi Tr^2$
- (c) $12\pi Tr^2$
- (d) $24\pi Tr^2$

56. Eight spherical rain drops of the same mass and radius are falling down with a terminal speed of 6 cm s^{-1} . If they coalesce to form one big drop, what will be the terminal speed of bigger drop? (Neglect the buoyancy of the air)

- (a) 1.5 cm-s^{-1}
- (b) 6 cm -s^{-1}
- (c) 24 cm-s^{-1}
- (d) 32 cm-s^{-1}

57. A clock pendulum made of invar has a period of 0.5 s , at 20°C . If the clock is used in a climate where the temperature averages to 30°C , how much time does the clock lose in each oscillation?

(For invar, $\alpha = 9 \times 10^{-7} / ^\circ\text{C}$, $g = \text{constant}$)

- (a) $2.25 \times 10^{-6}\text{ s}$
- (b) $2.5 \times 10^{-7}\text{ s}$
- (c) $5 \times 10^{-7}\text{ s}$
- (d) $1.125 \times 10^{-6}\text{ s}$

58. A piece of metal weighs 45 g in air and 25 g in a liquid of density $1.5 \times 10^3 \text{ kg-m}^{-3}$ kept at 30°C .

When the temperature of the liquid is raised to 40°C , the metal piece weighs 27 g. The density of liquid at 40°C is $1.25 \times 10^3 \text{ kg-m}^{-3}$. The coefficient of linear expansion of metal is

- (a) $1.3 \times 10^{-3}/^\circ\text{C}$
(b) $5.2 \times 10^{-3}/^\circ\text{C}$
(c) $2.6 \times 10^{-3}/^\circ\text{C}$
(d) $0.26 \times 10^{-3}/^\circ\text{C}$
59. An ideal gas is subjected to a cyclic process ABCD as depicted in the p- V diagram given below:

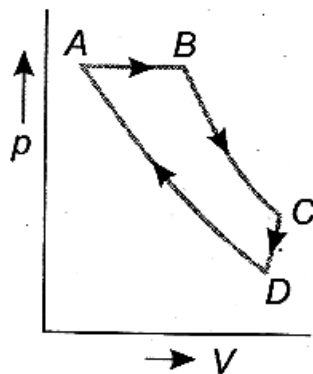

Which of the following curves represents the equivalent cyclic process?

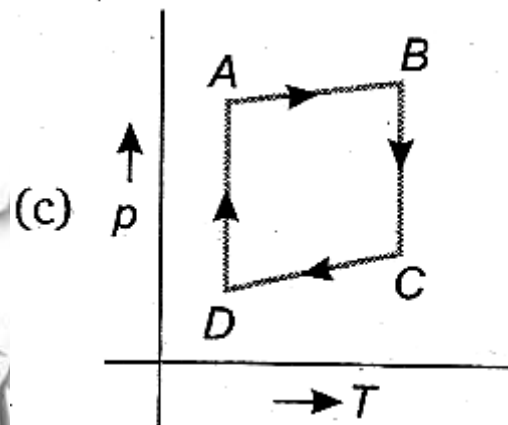
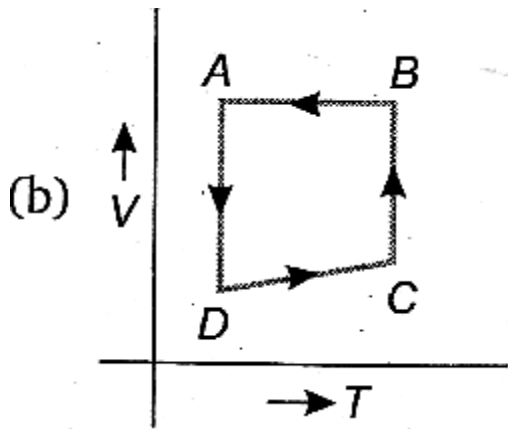
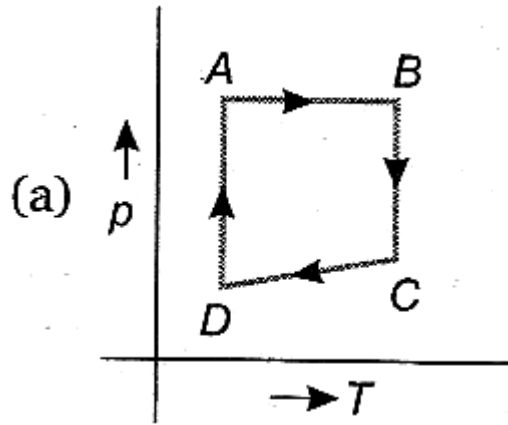

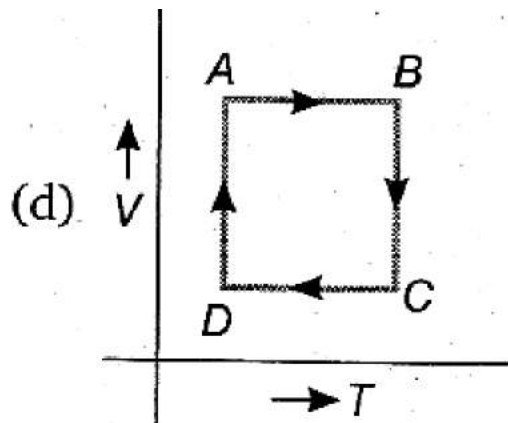

60. An ideal gas is subjected to cyclic process involving four thermodynamic states, the amounts of heat (Q) and work (W) involved in each of these states are

$$Q_1 = 6000 \text{ J,}$$

$$Q_2 = -5500 \text{ J;}$$

$$Q_3 = -3000 \text{ J;}$$

$$Q_4 = 3500 \text{ J}$$

$$W_1 = 2500 \text{ J;}$$

$$W_2 = -1000 \text{ J;}$$

$$W_3 = -1200 \text{ J;}$$

$$W_4 = x \text{ J.}$$

The ratio of the net work done by the gas to the total heat absorbed by the gas is η . The values of x and η respectively are

- (a) 500; 7.5%
 (b) 700; 10.5%
 (c) 1000; 21%
 (d) 1500; 15%

61. Two cylinders A and B fitted with pistons contain equal number of moles of an ideal mono atomic gas at 400 K. The piston of A is free to move while that of B is held fixed. Same amount of heat energy is given to the gas in each cylinder. If the rise in temperature of the gas in A is 42 K, the rise in temperature of the gas in B is
- (a) 21 K
(b) 35 K
(c) 42 K
(d) 70 K
62. Three rods of same dimensional have thermal conductivity 3 K, 2 K and K. They are arranged as shown in the figure below

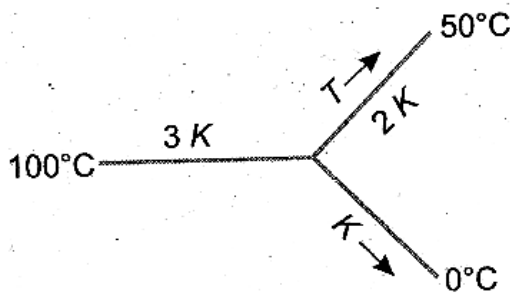

Then, the temperature of the junction in steady state is

- (a) $\frac{200}{3}^\circ\text{C}$
(b) $\frac{100}{3}^\circ\text{C}$
(c) 75°C
(d) $\frac{50}{3}^\circ\text{C}$

63. Two sources A and B are sending notes of frequency 680 Hz. A listener moves from A and B with a constant velocity u . If the speed of sound in air is 340 ms^{-1} , what must be the value of u so that he hears 10 beats per second?
- (a) 2.0 ms^{-1}
 - (b) 2.5 ms^{-1}
 - (c) 3.0 ms^{-1}
 - (d) 3.5 ms^{-1}
64. Two identical piano wires have a fundamental frequency of 600 cycle per second when kept under the same tension. What fractional increase in the tension of one wires will lead to the occurrence of 6 beats per second when both wires vibrate simultaneously?
- (a) 0.01
 - (b) 0.02
 - (c) 0.03
 - (d) 0.04
65. In the Young's double slit experiment, the intensities at two points P_1 and P_2 on the screen are respectively I_1 and I_2 , If P_1 is located at the centre of a bright fringe and P_2 is located at a distance equal to a quarter of fringe width from P_1 , then $\frac{I_1}{I_2}$ is
- (a) 2
 - (b) $\frac{1}{2}$
 - (c) 4

(d) 16

66. In Young's double slit experiment, the 10th maximum of wavelength λ_1 is at a distance of y_1 from the central maximum. When the wavelength of the source is changed to λ_2 , 5th maximum is at a distance of y_2 from its central maximum. The ratio $\frac{y_1}{y_2}$ is

(a) $\frac{2\lambda_1}{\lambda_2}$

(b) $\frac{2\lambda_2}{\lambda_1}$

(c) $\frac{\lambda_1}{2\lambda_2}$

(d) $\frac{\lambda_2}{2\lambda_1}$

67. Four light sources produce the following four waves:

(i) $y_1 = a' \sin (\omega t + \phi_1)$

(ii) $y_2 = a' \sin 2\omega t$

(iii) $y_3 = a' \sin (\omega t + \phi_2)$

(iv) $y_4 = a' \sin (3 \omega t + \phi)$

Super Position of which two waves give rise to interference?

(a) (i) and (ii)

(b) (ii) and (iii)

(c) (i) and (iii)

(d) (iii) and (iv)

68. The two lenses of an achromatic doublet should have www.examrace.com

- (a) Equal powers
 - (b) Equal dispersive powers
 - (c) Equal ratio of their power and dispersive power
 - (d) Sum of the product of their powers and dispersive power equal to zero
69. Two bar magnets A and B are placed one over the other and are allowed to vibrate in a vibration magnetometer. They make 20 oscillations per minute when the similar poles of A and B are on the same side, while they make 15 oscillations per minute when their opposite poles lie on the same side. If M_A and M_B are the magnetic moments of A and B and if $M_A > M_B$, the ratio of M_A and M_B is
- (a) 4: 3
 - (b) 25:7
 - (c) 7: 5
 - (d) 25: 16
70. A bar magnet is 10 cm long is kept with its north (N)-pole pointing north. A neutral point is formed at a distance of 15 cm from each pole:
- Given the horizontal component of earth's field is 0.4 Gauss, the pole strength of the magnet is
- (a) 9 A-m
 - (b) 6.75 A-m
 - (c) 27 A-m
 - (d) 1.35 A-m

71. An infinitely long thin straight wire has uniform linear charge density of $\frac{1}{3} \text{ cm}^{-1} \text{ cm}^{-1}$. Then, the magnitude of the electric intensity at a point 18 cm away is

(given $\epsilon_0 = 8.8 \times 10^{-12} \text{ C}^2\text{Nm}^{-2}$)

- (a) $0.33 \times 10^{11} \text{ NC}^{-1}$
(b) $3 \times 10^{11} \text{ NC}^{-1}$
(c) $0.66 \times 10^{11} \text{ NC}^{-1}$
(d) $1.32 \times 10^{11} \text{ NC}^{-1}$
72. Two point charges $-q$ and $+q$ are located at point's $(0, 0, -a)$ and, $(0, 0, a)$ respectively. The electric potential at a point $(0, 9, z)$, where $z > a$ is

(a) $\frac{qa}{4\pi\epsilon_0 z^2}$

(b) $\frac{q}{4\pi\epsilon_0 a}$

(c) $\frac{2qa}{4\pi\epsilon_0 z^2 - a^2}$

(d) $\frac{2qa}{4\pi\epsilon_0 z^2 + a^2}$

73. In the adjacent shown circuit, a voltmeter of internal resistance R , when connected across B and C reads $\frac{100}{3} \text{ V}$.

Neglecting the internal resistance of the battery, the value of R is

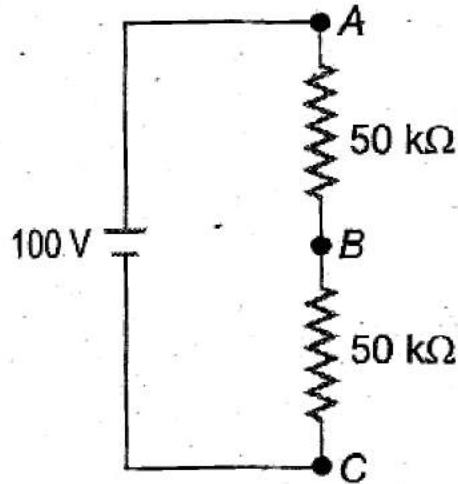

- (a) 100 k Ω
- (b) 75 k Ω
- (c) 50 k Ω
- (d) 25 k Ω

74. A cell in secondary circuit gives null deflection for 2.5 m length of potentiometer having 10 m length of wire. If the length of the potentiometer wire is increased by 1 m without changing the cell in the primary, the position of the null point now is -

- (a) 3.5 m
- (b) 3 m
- (c) 2.75 m
- (d) 2.0 m

75. The following series L-C-R circuit, when driven by an emf source of angular frequency 70 kilo-radians per second, the circuit effectively behaves like

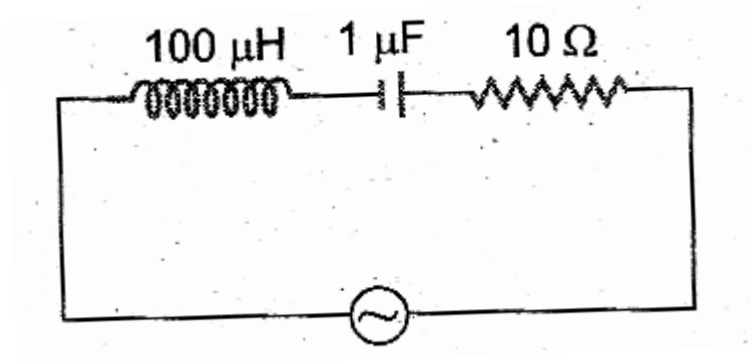

- (a) Purely resistive circuit
- (b) Series R-L circuit
- (c) Series R-C circuit
- (d) Series L-C circuit with $R = 0$
76. A wire of length l is bent into a circular loop of radius R and carries a current I . The magnetic field at the centre of the loop is B . The same wire is now bent into a double loop of equal radii. If both loops carry the same current I and it is in the same direction, the magnetic field at the centre of the double loop will be -
- (a) Zero
- (b) $2B$
- (c) $4B$
- (d) $8B$
77. An infinitely long straight conductor is bent into the shape as shown below. It carries a current of I ampere and the radius of the circular loop is R metre. Then, the magnitude of magnetic induction at the centre of the circular loop is -

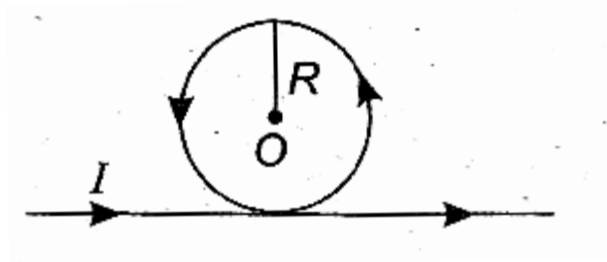

- (a) $\frac{\mu_0 I}{2\pi R}$
- (b) $\frac{\mu_0 nI}{2R}$
- (c) $\frac{\mu_0 I}{2\pi R} \pi + 1$
- (d) $\frac{\mu_0 I}{2\pi R} \pi - 1$

76. The work function of a certain metal is 3.31×10^{-19} J. Then, the maximum kinetic energy of photoelectrons emitted by incident radiation of wavelength 5000 Å is

(Given, $h = 6.62 \times 10^{-34}$ J-s,
 $c = 3 \times 10^8$ ms⁻¹. $e = 1.6 \times 10^{-19}$ C)

- (a) 248 eV
- (b) 0.41 eV
- (c) 2.07 eV
- (d) 0.82 eV

79. A photon of energy E ejects; a photoelectron from a metal surface whose work function is W_0 . If this electron enters into a uniform magnetic field of induction B in a direction perpendicular to the field and describes a circular path of radius r , then the radius r is given by, (in the usual notation)

- (a) $\frac{2m \sqrt{E - W_0}}{eB}$

(b) $\frac{2m E - W_0}{eB}$

(c) $\frac{2e E - W_0}{mB}$

(d) $\frac{2m E - W_0}{eB}$

80. Two radioactive materials X_1 and X_2 have decay constants 10λ and λ respectively. If initially they have the same number of nuclei, then the ratio of the number of nuclei of X_1 to that of X_2 will be $1/e$ after a time

(a) $(1/10\lambda)$

(b) $1/(11\lambda)$

(c) $11/(10\lambda)$

(d) $1/(9\lambda)$

81. Currents flowing in each of the following circuits A and B respectively are

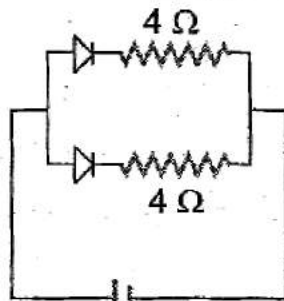

8 V
(Circuit A)

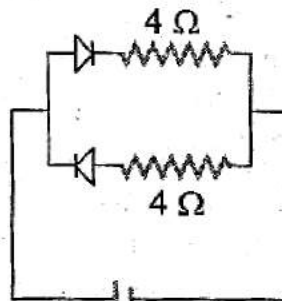

8 V
(Circuit B)

(a) 1 A, 2 A

(b) 2 A, 1 A

(c) 4 A, 2 A

(d) 2 A, 4 A

82. A bullet of mass 0.02 kg travelling horizontally with velocity 250 ms^{-1} strikes a block of wood of mass 0.23 kg which rests on a rough horizontal surface. After the impact, the block and bullet move together and come to rest after travelling a distance of 40 m. The coefficient of sliding friction of the rough surface is ($g = 9.8 \text{ ms}^{-2}$)

(a) 0.75

(b) 0.61

(c) 0.51

(d) 0.30

83. Two persons A and B are located in X - Y plane at the points (0, 0) and (0, 10) respectively. (The distances are measured in MKS unit). At a time $t = 0$, they start moving simultaneously with velocities $v_A = 2j \text{ ms}^{-1}$ and $v_B = 2i \text{ ms}^{-1}$ respectively. The time after which A and B are at their closest distance is

(a) 2.5 s

(b) 4 s

(c) 1 s

(d) $\frac{10}{2} \text{ s}$

84. A rod of length l is held vertically stationary with its lower end located at a point P, on the horizontal plane. When the rod is released to topple about P, the velocity of the upper end of the rod with which it hits the ground is

(a) $\frac{g}{l}$

(b) $\frac{3gl}{r}$

(c) $3 \frac{g}{l}$

(d) $\frac{3g}{l}$

85. A wheel of radius 0.4 m can rotate freely about its axis as shown in the figure. A string is wrapped over its rim and a mass of 4 kg is hung. An angular acceleration of 8 rad-s^{-2} is produced in it due to the torque. Then, moment of inertia of the wheel is ($g = 10 \text{ ms}^{-2}$)

(a) 2 kg-m^2

(b) 1 kg-m^2

(c) -4 kg-m^2

(d) 8 kg-m^2

CHEMISTRY

86. Given that $\Delta H_f(\text{H}) = 218 \text{ kJ/mol}$, express the H-H bond energy in kcal/mol.

(a) 52.15

(b) 911

(c) 104

(d) 52153

87. Identify the alkyne in the following sequence of reactions,

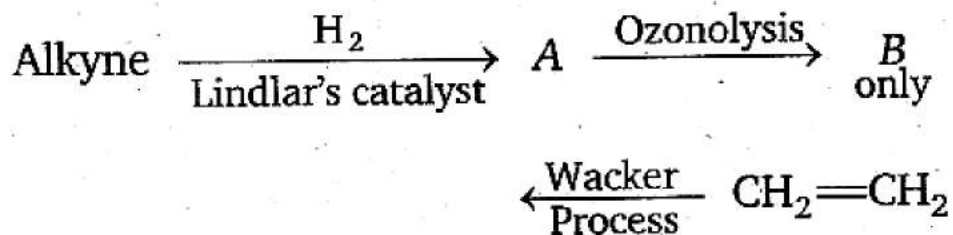

- (a) $\text{H}_3\text{C} - \text{C} \equiv \text{C} - \text{CH}_3$
- (b) $\text{H}_3\text{C} - \text{CH}_2 - \text{C} \equiv \text{CH}$
- (c) $\text{H}_2\text{C} = \text{CH} - \text{C} \equiv \text{CH}$
- (d) $\text{HC} = \text{C} - \text{CH}_2 - \text{C} \equiv \text{CH}$
88. Fluorine reacts with dilute NaOH and forms a gaseous product A. The bond angle in the molecule of A is
- (a) $104^\circ 40'$
- (b) 103°
- (c) 107°
- (d) $109^\circ 28'$
89. One mole of alkene X on ozonolysis gave one mole of acetaldehyde and one mole of acetone. The IUPAC name of X is
- (a) 2-methyl-2-butene
- (b) 2-methyl-1-butene
- (c) 2-butene
- (d) 1-butene
90. The number of $p\pi-d\pi$ 'pi' bonds present in XeO_3 and XeO_4 molecules, respectively are

- (a) 3, 4
(b) 4, 2
(c) 2, 3
(d) 3, 2
91. The wavelengths of electron waves in two orbits is 3: 5. The ratio of kinetic energy of electrons will be
(a) 25: 9
(b) 5: 3
(c) 9: 25
(d) 3: 5
92. Which one of the following sets correctly represents the increase in the paramagnetic property of the ions?
(a) $\text{Cu}^{2+} > \text{V}^{2+} > \text{Cr}^{2+} > \text{Mn}^{2+}$
(b) $\text{Cu}^{2+} < \text{Cr}^{2+} < \text{V}^{2+} < \text{Mn}^{2+}$
(c) $\text{Cu}^{2+} < \text{V}^{2+} < \text{Cr}^{2+} < \text{Mn}^{2+}$
(d) $\text{V}^{2+} < \text{Cu}^{2+} < \text{Cr}^{2+} < \text{Mn}^{2+}$
93. Electrons with a kinetic energy of 6.023×10^4 J/mol are evolved from the surface of a metal, when it is exposed to radiation of wavelength of 600 nm. The minimum amount of energy required to remove an electron from the metal atom is
(a) 2.3125×10^{19} J
(b) 3×10^{-19} J
(c) 6.02×10^{-19} J
(d) 6.62×10^{-34} J

94. The chemical entities present in thermosphere of the atmosphere are

- (a) O^{+2}, O^+, NO^+
- (b) O_3
- (c) N_2, O_2, CO_2, H_2O
- (d) O_3, O^{+2}, O_2

95. The type of bonds present in sulphuric anhydride are -

- (a) 3σ and three $p\pi - d\pi$
- (b) 3σ one $p\pi - p\pi$ and two $p\pi - d\pi$
- (c) 2σ and three $p\pi - d\pi$
- (d) 2σ and two $p\pi - d\pi$

96. In Gattermann reaction, a diazonium group is replaced by X using Y and Y are -

- | | <u>X</u> | <u>Y</u> |
|-----|--------------|--------------|
| (a) | Cl^\ominus | Cu/HCl |
| (b) | Cl^\oplus | $CuCl_2/HCl$ |
| (c) | Cl^\oplus | $CuCl_2/HCl$ |
| (d) | Cl_2 | Cu_2O/HCl |

97. Which pair of oxyacids of phosphorus contains 'P-H' bonds?

- (a) H_3PO_4, H_3PO_3
- (b) $H_3PO_3, H_4P_2O_7$

- (c) $\text{H}_3\text{PO}_3, \text{H}_3\text{PO}_2$
- (d) $\text{H}_3\text{PO}_2, \text{HPO}_3$
98. Dipole moment of $\text{HCl} = 1.03 \text{ D}$, $\text{HI} = 0.38 \text{ D}$. Bond length of $\text{HCl} = 1.3 \text{ \AA}$ and $\text{HI} = 1.6 \text{ \AA}$. The ratio of fraction of electric charge, δ , existing on each atom in HCl and HI is
- (a) 12: 1
- (b) 2.7: 1
- (c) 3.3: 1
- (d) 1: 3.3
99. SiCl_4 on hydrolysis forms 'X' and HCl . Compound 'X' loses water at 1000°C and gives 'Y'. Compounds 'X' and 'Y' respectively are
- (a) $\text{H}_2\text{SiCl}_6, \text{SiO}_2$
- (b) $\text{H}_4\text{SiO}_4, \text{Si}$
- (c) SiO_2, Si
- (d) $\text{H}_4\text{SiO}_4, \text{SiO}_2$
100. 1.5 g of CdCl_2 was found to contain 0.9 g of Cd . Calculate the atomic weight of Cd .
- (a) 118
- (b) 112
- (c) 106.5
- (d) 53.25

101. Aluminium reacts with NaOH and forms compound 'X'. If the coordination number of aluminium in 'X' is 6, the correct formula of X is

- (a) $[\text{Al}(\text{H}_2\text{O})_4(\text{OH})_2]^+$
- (b) $[\text{Al}(\text{H}_2\text{O}_3)(\text{OH})_3]$
- (c) $[\text{Al}(\text{H}_2\text{O})_2(\text{OH})_4]^-$
- (d) $[\text{Al}(\text{H}_2\text{O})_6](\text{OH})_3$

102. The average kinetic energy of one molecule of an ideal gas at 27°C and 1 atm pressure is

- (a) $900 \text{ cal K}^{-1} \text{ mol}^{-1}$
- (b) $6.21 \times 10^{-21} \text{ JK}^{-1} \text{ molecule}^{-1}$
- (c) $336.7 \text{ JK}^{-1} \text{ molecule}^{-1}$
- (d) $3741.3 \text{ JK}^{-1} \text{ mol}^{-1}$

103. **Assertion (A)** K, Rb and Cs form superoxides. Reason (R) The stability of the superoxides increases from 'K' to 'Cs' due to decrease in lattice energy.

The correct answer is

- (a) Both (A) and (R) are true and (R) is the correct explanation of (A)
- (b) Both (A) and (R) are true but (R) is not the correct explanation of (A)
- (c) (A) is true but (R) is not true
- (d) (A) is not true but (R) is true

104. How many 'mL' of perhydrol is required to produce sufficient oxygen which can be used to completely convert 2L of SO_2 gas

to SO_3 gas?

- (a) 10 mL
- (b) 5 mL
- (c) 20 mL
- (d) 30 mL

105. pH of a buffer solution decreases by 0.02 units when 0.12 g of acetic acid is added to 250 mL of a buffer solution of acetic acid and potassium acetate at 27°C . The buffer capacity of the solution is

- (a) 0.1
- (b) 10
- (c) 1
- (d) 0.4

106. Match the following.

List I		List II	
(A)	Felspar	(I)	$[\text{Ag}_3\text{SbS}_3]$
(B)	Asbestos	(II)	$\text{Al}_2\text{O}_3 \cdot \text{H}_2\text{O}$
(C)	Pyrrargyrite	(III)	$\text{MgSO}_4 \cdot \text{H}_2\text{O}$
(D)	Diaspore	(IV)	KAlSi_3O_8
		(V)	$\text{CaMg}_3(\text{SiO}_3)_4$

The correct answer is

- | | (A) | (B) | (C) | (D) |
|-----|-----|-----|-----|-----|
| (a) | IV | V | II | I |
| (b) | IV | V | I | II |
| (c) | IV | I | III | II |
| (d) | II | V | IV | I |

107. Which one of the following order is correct for the first ionisation energies of the elements?

- (a) $B < Be < N < O$
 (b) $Be < B < N < O$
 (c) $B < Be < O < N$
 (d) $B < O < Be < N$

108. What are X and Y in the following reaction sequence?

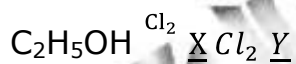

- (a) C_2H_5Cl, CH_3CHO
 (b) CH_3CHO, CH_3CO_2H
 (c) CH_3CHO, CCl_3CHO
 (d) C_2H_5Cl, CCl_3CHO

109. What are A B C in the following reactions?

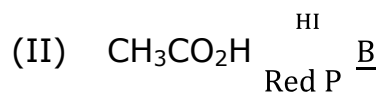
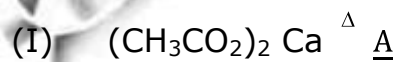

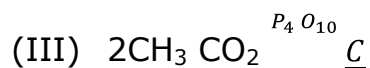

	<u>A</u>	<u>B</u>	<u>C</u>
(a)	C_2H_6	CH_3COCH_3	$(\text{CH}_3\text{CO})_2\text{O}$
(b)	$(\text{CH}_3\text{CO})_2\text{O}$	C_2H_6	CH_3COCH_3
(c)	CH_3COCH_3	C_2H_6	$(\text{CH}_3\text{CO})_2\text{O}$
(d)	CH_3COCH_3	$(\text{CH}_3\text{CO})_2\text{O}$	C_2H_6

110. One per cent composition of an organic compound A is, carbon: 85.71% and hydrogen 14.29%. Its vapour density is 14. Consider the following reaction sequence

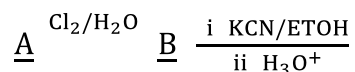

Identify C

- (a) $\text{CH}_3 - \underset{\begin{array}{c} | \\ \text{OH} \end{array}}{\text{CH}} - \text{CO}_2\text{H}$
- (b) $\text{HO} - \text{CH}_2 - \text{CH}_2 - \text{CO}_2\text{H}$
- (c) $\text{HO} - \text{CH}_2 - \text{CO}_2\text{H}$
- (d) $\text{CH}_3 - \text{CH}_2 - \text{CO}_2\text{H}$

111. How many tripeptides can be prepared by linking the amino acids glycine, alanine and phenyl alanine?

- (a) One

- (b) Three
- (c) Six
- (d) Twelve

112. A codon has a sequence of A, and specifies a particular B that is 'to be incorporated into a C. What are A, B, C?

- | | <u>A</u> | <u>B</u> | <u>C</u> |
|-----|----------|--------------|--------------|
| (a) | 3 bases | amino acid | carbohydrate |
| (b) | 3 acids | carbohydrate | protein |
| (c) | 3 bases | protein | amino acid |
| (d) | 3 bases | amino acid | protein |

113. Parkinson's disease is linked to abnormalities in the levels of dopamine in the body. The structure of dopamine is -

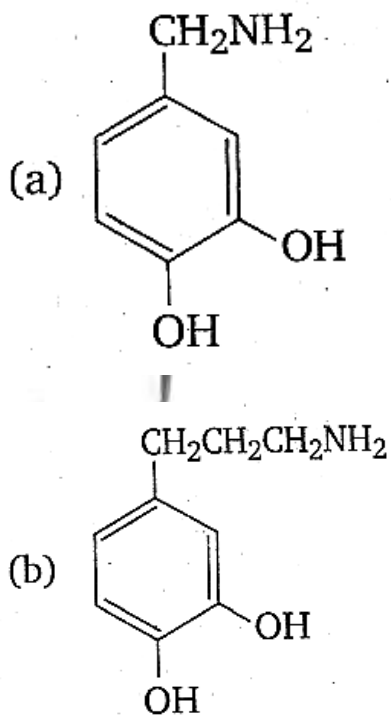

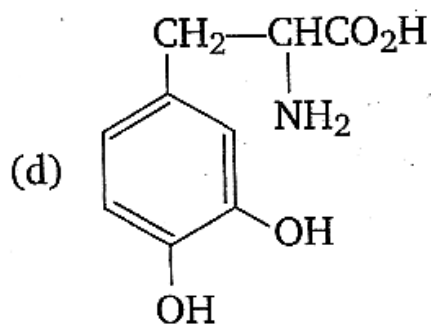
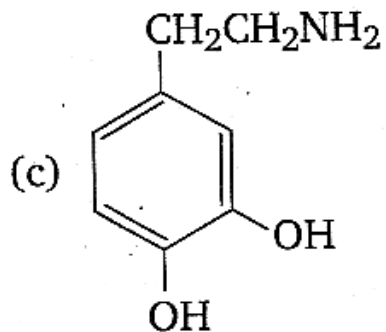

114. During the depression in freezing point experiment, an equilibrium is established between the molecules of -

- (a) Liquid solvent and solid solvent
- (b) Liquid solute and solid solvent
- (c) Liquid solute and solid solute
- (d) Liquid solvent and solid solute

115. Consider the following reaction,

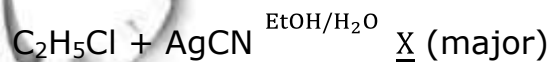

Which one of the following statements is true for X?

- (I) It gives propionic acid on hydrolysis
- (II) It has an ester functional group

(III) It has a nitrogen linked to ethyl carbon

(IV) It has a cyanide group

(a) IV

(b) III

(c) II

(d) I

116. For the following cell reaction,



$$\Delta G_f^\ominus / (\text{AgCl}) = -109 \text{ kJ/mol}$$

$$\Delta G_f^\ominus / (\text{Cl}^\ominus) = -129 \text{ kJ/mol}$$

$$\Delta G_f^\ominus / (\text{Ag}^+) = 78 \text{ kJ/mol}$$

E^\ominus of the cell is

(a) - 0.60 V

(b) 0.60 V

(c) 6.0 V

(d) None of these

117. The synthesis of crotonaldehyde from acetaldehyde is an example of reaction

(a) nucleophilic addition

(b) elimination

(c) electrophilic addition

(d) nucleophilic addition-elimination

118. At 25°C, the molar conductances at infinite dilution for the strong electrolytes NaOH, NaCl and BaCl₂ are 248×10^{-4} , 126×10^{-4} and $280 \times 10^{-4} \text{ Sm}^2 \text{ mol}^{-1}$ respectively, $\lambda_m^\circ \text{ Ba(OH)}_2$ in $\text{Sm}^2 \text{ mol}^{-1}$ is –

- (a) 52.4×10^{-4}
- (b) 524×10^{-4}
- (c) 402×10^{-4}
- (d) 262×10^{-4}

119. The cubic unit cell of a metal (molar mass = 63.55 g mol^{-1}) has an edge length of 362 pm.

Its density is 8.92 g cm^{-3} the type of unit cell is

- (a) Primitive
- (b) Face centred
- (c) Body centred
- (d) End centred

120. The equilibrium constant for the given reaction is 100.

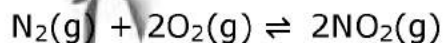

What is the equilibrium constant for the reaction given below?

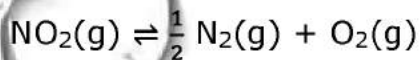

- (a) 10
- (b) 1
- (c) 0.1

(d) 0.01

121. For a first order reaction at 27°C, the ratio of time required for 75% completion to 25% completion of reaction is -

(a) 3.0

(b) 2.303

(c) 4.8

(d) 0.477

122. The concentration of an organic compound in chloroform is 6.15 g per 100 mL of solution. A portion of this solution in a 5 cm polarimeter tube causes an observed rotation of -1.2° . What is the specific rotation of the compound?

(a) $+12^\circ$

(b) -3.9°

(c) -39°

(d) $+61.5^\circ$

123. 20 mL of 0.1 M acetic acid is mixed with 50 mL of potassium acetate. K_a of acetic acid = 1.8×10^{-5} at 27°C. Calculate concentration of potassium acetate if pH of the mixture is 4.8.

(a) 0.1 M

(b) 0.04 M

(c) 0.4 M

(d) 0.02 M

124. Calculate ΔH° for the reaction,

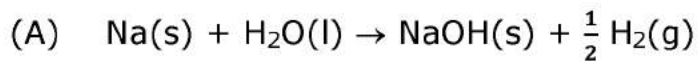

$$\Delta H^\circ = -146 \text{ kJ}$$

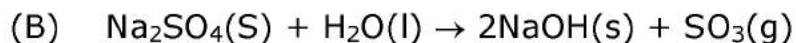

$$\Delta H^\circ = + 418 \text{ kJ}$$

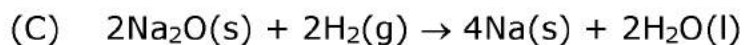

$$\Delta H^\circ = + 259 \text{ kJ}$$

(a) + 823 kJ

(b) -581 kJ

(c) -435 kJ

(d) +531 kJ

125. Which one of the following is most effective in causing the coagulation of an As_2S_3 sol?

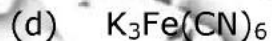

REASONING

Directions (Q. 126-128): In each of the following questions, choose the most appropriate alternative to fill in the blank.

126. It is difficult to believe what he tells us because his account of any event is always full of of all sorts.

- (a) Discrepancies
- (b) Differences
- (c) Discretions
- (d) Distinctions

127. The bank clerk tried to money from his friend's account.

- (a) Empower
- (b) Embellish
- (c) Embroil
- (d) Embezzle

128. Eight scientists have the national awards for outstanding contribution and dedication to the profession-

- (a) Bestowed
- (b) Picked
- (c) Bagged
- (d) Conferred

Directions (Q. 129-131): In the following questions, some parts have been jumbled up. You are required to rearrange these parts, which are labelled P, Q, R and S, to produce the correct sentence.

129. Freedom, is the restricted kind in the sense/(P), the rich and

poor woman/(Q), that a wide gulf separates/ (R), which a modern woman enjoys(S)

- (a) P S R Q
- (b) S R Q P
- (c) R Q P S
- (d) S P R Q

130. In life, some rules are/(P), as in business/(Q), they seem almost instinctive/(R), learnt so early that/(S)

- (a) R S P Q
- (b) Q P S R
- (c) R P S Q
- (d) Q S P R

131. Kapil, left in an aeroplane/(P), after reading a sailing magazine/(Q), had decided/(R), to build his own boat nine years earlier/(S)

- (a) P R Q S
- (b) R S Q P
- (c) R Q P S
- (d) P S R Q

Directions (Q. 132-134): In each of the following questions is choose the alternative which is most nearly the same in meaning to the word given in capital letters.

132. DENOUEMENT

- (a) Outcome
- (b) Eschew
- (c) Action
- (d) Character

133. GAUCHE

- (a) Vain
- (b) Rich
- (c) Polished
- (d) Tactless

134. ACCOLADE

- (a) Honour
- (b) Appreciation
- (c) Greeting
- (d) Gift

Directions (Q. 135-137): In each of the following questions, choose the alternative which is opposite in meaning to the word given in capital letters.

135. REPRIMAND

- (a) Reward

- (b) Appreciate
- (c) Encourage
- (d) Praise

136. IMPERTINENT

- (a) Polite
- (b) Indifferent
- (c) Unpleasant
- (d) Stubborn

137. EQUIVOCAL

- (a) Mistaken
- (b) Quaint
- (c) Clear
- (d) Universal

Directions (Q. 138-140): In each of the following questions, choose the alternative which can be substituted for the given words/sentence.

138. Design made by putting together coloured pieces of glass or stones –

- (a) Oleograph
- (b) Mosaic
- (c) Tracery
- (d) Relief

139. The doctrine that human soul passes from one body to another at the time of death

- (a) Metamorphosis
- (b) Transition
- (c) Transmigration
- (d) Extrapolation

140. A style in which a writer makes a display of his knowledge

- (a) Pedantic
- (b) Ornate
- (c) Verbose
- (d) Pompous

Directions (Q. 141): In each of these questions, two figure/words are given to the left of the sign :: and one figures word to the right of the sign:: with four alternatives under it out. of which one of the alternatives has the same relationship with the figures/words to the right of the sign:: as between the two figures/words to the left of the sign (::). Find the correct alternative.

141.

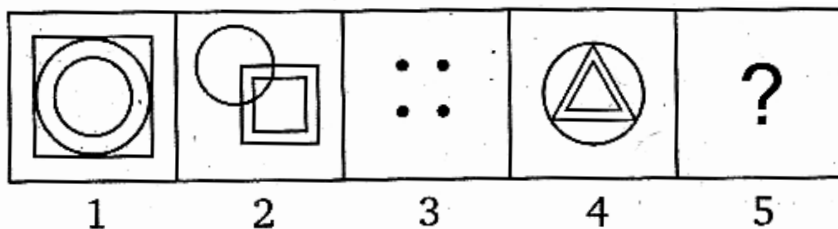

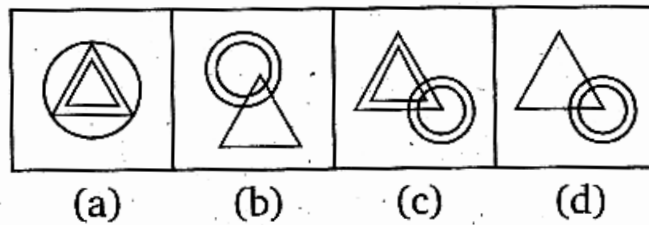

Directions (Q. 142): In the following question, choose the missing word or sign (?) on the basis of the relationship between the words given on the left/right hand side of the signs.

142. Doctor: Nurse:: ? : Follower

- (a) Worker
- (b) Employer
- (c) Union
- (d) Leader

143. One of the, numbers does not fit into the series.

Find the wrong number

1788, 892, 444, 220, 112, 52, 24

- (a) 52
- (b) 112
- (c) 220
- (d) 444

Directions (Q. 144): In the question below is given a statement followed by three assumptions numbered I, II and III. An assumption is something supposed or taken for granted. You

have to consider the statement and the following assumptions and decide which of the assumption(s) is/are implicit in the statement.

144. **Statement:** Large number of people affected by the flood in the area gathered at the relief camp for food, water and shelter organized by the state government

Assumptions:

- I. The relief camp has enough supplies to provide food and water to the affected people in the area.
 - II. All those whose houses are submerged can be accommodated in the temporary shelters.
 - III. Many more affected people are yet to reach the relief camp.
- (a) Only I is implicit
 - (b) Only I and II are implicit
 - (c) Only II is implicit
 - (d) Only II and III are implicit

145. Identify the missing part of the figure and select it from the given alternatives.

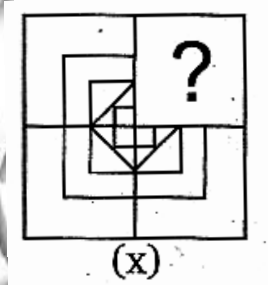

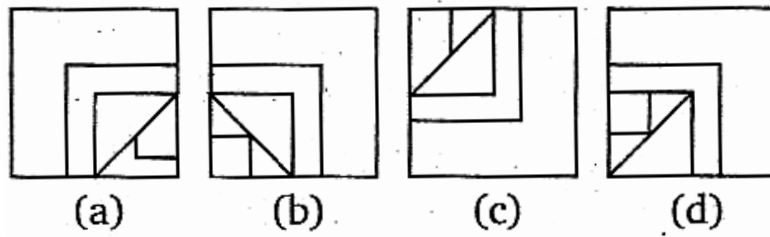

146. Figure (x) is embedded in any one of the four alternative figures. Choose the alternative which contains figure (x).

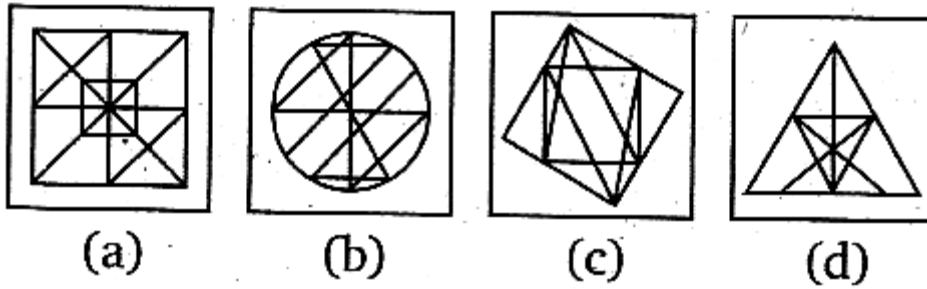
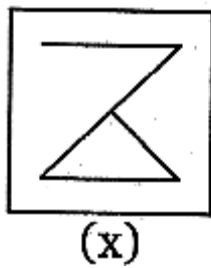

147. Which symbol will appear on the opposite surface to the symbol x?

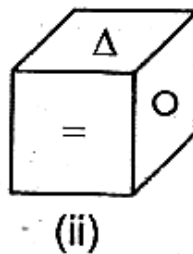
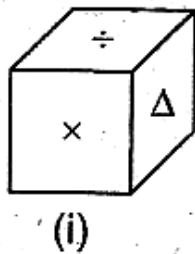

- (a) '÷'
- (b) 'x'
- (c) '+'
- (d) '-'

148. The three figures marked X, Y, Z show the manner in which a paper is folded step by step and then cut. From the answer figures (a), (b), (c), (d), select the one, showing the unfolded position of the Paper after the cut.

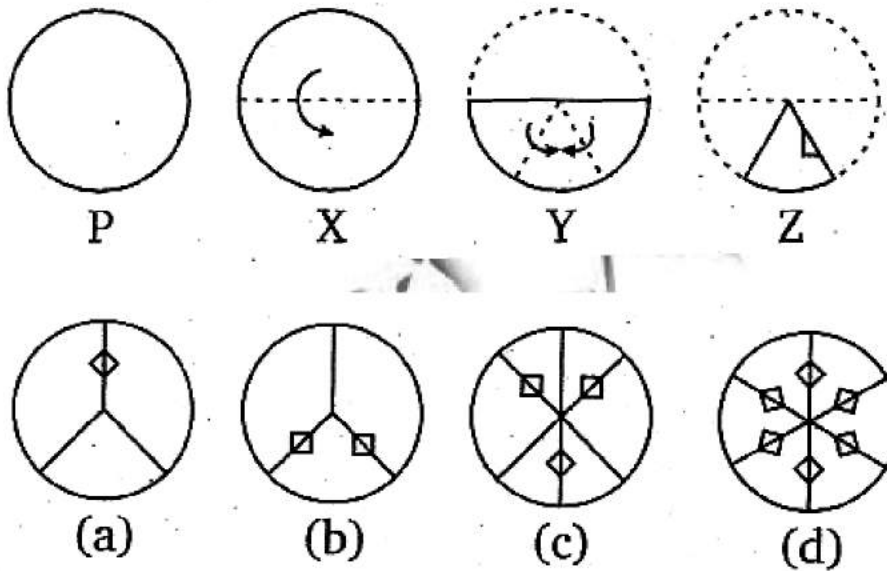

149. SERVANT: QGPXYPR :: KING?

- (a) MKPI
- (b) IKLI
- (c) IGLE
- (d) IGPI

149. If P denotes ' \div '

Q denotes, ' \times '

R denotes '+'

S denotes '-',

Then what is the value of $18 Q 12 P 4 R 5 S 6 = ?$

(a) 64

(b) 81

(c) 53

(d) 24

Answers

www.examrace.com

MATHEMATICS

1. (c)	2. (c)
3. (b)	4. (d)
5. (c)	6. (b)
7. (a)	8. (d)
9. (d)	10. (c)
11. (d)	12. (b)
13. (a)	14. (c)
15. (c)	16. (c)
17. (a)	18. (a)
19. (a)	20. (c)
21. (a)	22. (d)
23. (b)	24. (d)
25. (b)	26. (c)
27. (c)	28. (a)
29. (b)	30. (d)
31. (b)	32. (b)
33. (a)	34. (b)
35. (c)	36. (c)
37. (c)	38. (d)
39. (b)	40. (b)
41. (c)	42. (c)
43. (a)	44. (b)

45. (b)	
----------------	--

PHYSICS

46. (d)	47. (c)
48. (a)	49. (a)
50. (a)	51. (c)
52. (b)	53. (d)
54. (d)	55. (d)
56. (c)	57. (a)
58. (c)	59. (a)
60. (b)	61. (c)
62. (a)	63. (b)
64. (b)	65. (d)
66. (a)	67. (c)
68. (d)	69. (b)
70. (d)	71. (a)
72. (c)	73. (c)
74. (c)	75. (c)
76. (c)	77. (c)
78. (b)	79. (d)
80. (d)	81. (c)
82. (c)	83. (a)
84. (b)	85. (a)

CHEMISTRY

86. (c)	87. (a)
88. (b)	89. (a)
90. (a)	91. (a)
92. (c)	93. (a)
94. (a)	95. (b)
96. (a)	97. (c)
98. (c)	99. (d)
100. (c)	101. (c)
102. (b)	103. (c)
104. (a)	105. (d)
106. (b)	107. (c)
108. (c)	109. (c)
110. (b)	111. (c)
112. (d)	113. (c)
114. (a)	115. (b)
116. (a)	117. (d)
118. (b)	119. (b)
120. (c)	121. (c)
122. (c)	123. (b)

124. (b)	125. (b)
-----------------	-----------------

REASONING

126. (a)	127. (d)
128. (c)	129. (d)
130. (b)	131. (b)
132. (a)	133. (d)
134. (b)	135. (b)
136. (a)	137. (c)
138. (b)	139. (c)
140. (a)	141. (d)
142. (d)	143. (b)
144. (b)	145. (b)
146. (b)	147. (d)
148. (b)	149. (a)
150. (c)	

Solutions
MATHEMATICS

1. Let $A = \{x \in \mathbb{R} : \frac{2x-1}{x^3+4x^2+3x}\}$

$$\begin{aligned}\text{Now, } x^3 + 4x^2 + 3x &= x(x^2 + 4x + 3) \\ &= x(x + 3)(x + 1)\end{aligned}$$

$$A = \mathbb{R} - \{0, -1, -3\}$$

2. The total number of subsets of given set is $2^9 = 512$

Even numbers are $\{2, 4, 6, 8\}$.

Case I When selecting only one even number.

$$= {}^4C_1 = 4$$

Case II When selecting only two even numbers

$$= {}^4C_2 = 6$$

Case III When selecting only three even numbers.

$$= {}^4C_3 = 4$$

Case IV When selecting only four even numbers = ${}^4C_4 = 1$

\therefore Required number of ways

$$= 512 - (4 + 6 + 4 + 1) - 1$$

$$= 496$$

[Here, we subtract 1 for due to the null set]

3. Now, $(1 + x^2)^{12}(1 + x^{12} + x^{24} + x^{36})$

$$= [1 + {}^{12}C_1(x^2) + {}^{12}C_2(x^2)^2 + {}^{12}C_3(x^2)^3$$

$$+ {}^{12}C_4(x^2)^4 + {}^{12}C_5(x^2)^5 + {}^{12}C_6(x^2)^6$$

$$+ \dots + {}^{12}C_{12}(x^2)^{12}] \times (1 + x^{12} + x^{24} + x^{36})$$

$$\text{Coefficient of } x^{24} = {}^{12}C_6 + {}^{12}C_{12} + 1$$

$$= {}^{12}C_6 + 2$$

$$4. \quad \frac{1}{x-1} \cdot \frac{1}{x-2} = \frac{1}{-2} \cdot \frac{1}{1-x} \cdot \frac{1}{1-\frac{x}{2}}$$

$$= -\frac{1}{2} (1-x)^{-2} \left(1-\frac{x}{2}\right)^{-1}$$

$$= -\frac{1}{2} (1+2x+\dots) \left(1+\frac{x}{2}+\dots\right)$$

\therefore Coefficient of constant term is $-\frac{1}{2}$.

5. Given,

$$(x-a)(x-a-1) + (x-a-1)(x-a-2) + (x-a)(x-a-2) = 0$$

Let $x-a = t$, then

$$t(t-1) + (t-1)(t-2) + t(t-2) = 0$$

$$\Rightarrow t^2 - t + t^2 - 3t + 2 + t^2 - 2t = 0$$

$$\Rightarrow 3t^2 - 6t + 2 = 0$$

$$\Rightarrow t = \frac{6 \pm \sqrt{36-24}}{2 \cdot 3} = \frac{6 \pm 2\sqrt{3}}{2 \cdot 3}$$

$$\Rightarrow x-a = \frac{3 \pm \sqrt{3}}{3}$$

$$\Rightarrow x = a + \frac{3 \pm \sqrt{3}}{3}$$

Hence, x is real and distinct.

6. Given, $f(x) = x^2 + ax + b$ has imaginary roots.

$$\therefore \text{Discriminant, } D < 0 \Rightarrow a^2 - 4b < 0$$

$$\text{Now, } f'(x) = 2x + a$$

$$f''(x) = 2$$

$$\text{Also, } f(x) + f'(x) + f''(x) = 0 \quad \dots\dots\dots (i)$$

$$\Rightarrow x^2 + ax + b + 2x + a + 2 = 0$$

$$\Rightarrow x^2 + (a + 2)x + b + a + 2 = 0$$

$$\therefore x = \frac{-a+2 \pm \sqrt{a+2^2-4(a+b+2)}}{2}$$

$$= \frac{-a+2 \pm \sqrt{a^2-4b-4}}{2}$$

$$\text{Since, } a^2 - 4b < 0$$

$$a^2 - 4b - 4 < 0$$

Hence, Eq. (i) has imaginary roots.

7. Given,
$$\begin{vmatrix} 3 & 5 & x \\ 7 & x & 7 \\ x & 5 & 3 \end{vmatrix} = 0$$

$$\Rightarrow 3(3x - 35) - 5(21 - 7x) + x(35 - x^2) = 0$$

$$\Rightarrow 9x - 105 - 105 + 35x + 35x - x^3 = 0$$

$$\Rightarrow -x^3 - 79x + 210 = 0$$

$$\Rightarrow (x + 10)(x - 3)(x - 7) = 0$$

$$\Rightarrow x = -10, 3, 7$$

8. Let a and R be the first term and common ratio of a GP.

$$\therefore T_p = aR^{p-1} = x$$

$$T_q = aR^{q-1} = y$$

And $T_r = aR^{r-1} = z$

$\Rightarrow \log x = \log a + (p - 1) \log R$

$\log y = \log a + (q - 1) \log R$

and $\log z = \log a + (r - 1) \log R$

$$\therefore \begin{matrix} \log x & x & 1 & \log a + & p - 1 & \log R & p & 1 \\ \log y & y & 1 & \log a + & q - 1 & \log R & q & 1 \\ \log z & z & 1 & \log a + & r - 1 & \log R & r & 1 \end{matrix}$$

$$= \begin{matrix} \log a & p & 1 & p - 1 & \log R & p & 1 \\ \log a & q & 1 & q - 1 & \log R & q & 1 \\ \log a & r & 1 & r - 1 & \log R & r & 1 \end{matrix}$$

$$= \begin{matrix} 1 & p & 1 & p - 1 & p - 1 & 1 \\ \log a & 1 & q & 1 & q - 1 & q - 1 & 1 \\ 1 & r & 1 & r - 1 & r - 1 & r - 1 & 1 \end{matrix}$$

$C_2 \rightarrow C_2 - C_3$

$= 0 + 0 = 0$ (\because two columns are identical)

9. If matrix has no inverse it means the value of determinant should be zero.

$$\therefore \begin{vmatrix} 1 & -1 & x \\ 1 & x & 1 \\ x & -1 & 1 \end{vmatrix} = 0$$

If we put $x = 1$, then column Ist and IIIrd are identical.

Hence, option (d) is correct.

10. Let $z = x + iy$

Given, $\frac{z+2i}{2z+i} < 1$

$$\Rightarrow \frac{\overline{x^2 + y^2 + 4 + 4y}}{2x^2 + 2y^2 + 1 + 4y} < 1$$

$$\Rightarrow x^2 + y^2 + 4 + 4y < 4x^2 + 4y^2 + 1 + 4y$$

$$\Rightarrow 3x^2 + 3y^2 > 3$$

$$\Rightarrow x^2 + y^2 > 1$$

11. Let $f(x) = \sin^4 x + \cos^4 x$

$$= (\sin^2 x + \cos^2 x)^2 - 2 \sin^2 x \cos^2 x$$

$$= 1 - \frac{1}{4} \cdot 2 \sin^2 2x$$

$$= 1 - \frac{1}{4} (1 - \cos 4x)$$

$$= \frac{3}{4} + \frac{\cos 4x}{4}$$

$$\therefore \text{Period of } f(x) = \frac{2\pi}{4} = \frac{\pi}{2}$$

12. Now, $\tan(x - y) \tan y$

$$= \frac{\sin(x - y) \sin y}{\cos(x - y) \cos y} \times \frac{2}{2}$$

$$= \frac{\cos(x - 2y) - \cos x}{\cos(x - 2y) + \cos x}$$

$$= \frac{1 - \frac{\cos x}{\cos(x - 2y)}}{1 + \frac{\cos x}{\cos(x - 2y)}}$$

$$= \frac{1 - \lambda}{1 + \lambda} \quad \text{Given, } \lambda = \frac{\cos x}{\cos(x - 2y)}$$

13. It is a standard result.

$$\cos A \cos 2A \cos 2^2 A \dots \cos 2^{n-1} A$$

$$= \frac{\sin 2^n A}{2^n \sin A}$$

14. $\sin^2 x - \cos 2x = 2 - \sin 2x$

$$\Rightarrow 1 - \cos^2 x - (2 \cos^2 x - 1) = 2 - 2 \sin x \cos x$$

$$\Rightarrow -3 \cos^2 x + 2 \sin x \cos x = 0$$

$$\Rightarrow \cos x (2 \sin x - 3 \cos x) = 0$$

$$\Rightarrow \cos x = 0, (\because 2 \sin x - 3 \cos x \neq 0)$$

$$\Rightarrow x = 2n\pi \pm \frac{\pi}{2}$$

$$\Rightarrow x = (4n \pm 1) \frac{\pi}{2}$$

15. We know that, $2s = a + b + c$

$$\therefore \frac{a+b+c}{4b^2c^2} \frac{b+c-a}{4b^2c^2} \frac{c+a-b}{4b^2c^2} \frac{a+b-c}{4b^2c^2}$$

$$= \frac{2s}{4b^2c^2} \frac{2s-2a}{4b^2c^2} \frac{2s-2b}{4b^2c^2} \frac{2s-2c}{4b^2c^2}$$

$$= 4 \frac{s}{bc} \frac{s-a}{bc} \times \frac{s-b}{bc} \frac{s-c}{bc}$$

$$= 4 \cos^2 \frac{A}{2} \times \sin^2 \frac{A}{2}$$

$$= \sin^2 A$$

16. In $\triangle APD$

$$\tan 45^\circ = \frac{a}{AP} \Rightarrow AP = a$$

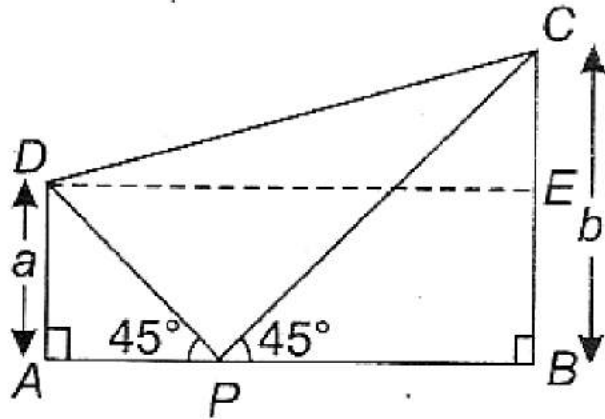

And in $\triangle BPC$, $\tan 45^\circ = \frac{b}{PB} \Rightarrow PB = b$

$\therefore DE = a + b$ and $CE = b - a$

$$\begin{aligned} \text{In } \triangle DEC, \quad DC^2 &= DE^2 + EC^2 \\ &= (a + b)^2 + (b - a)^2 \\ &= 2(a^2 + b^2) \end{aligned}$$

17. Now, $AB + 2AD + \mathbf{BC} - 2DC$
 $= AC + 2AD - 2DC$
 $= AC + 2(AC + CD) - 2DC$

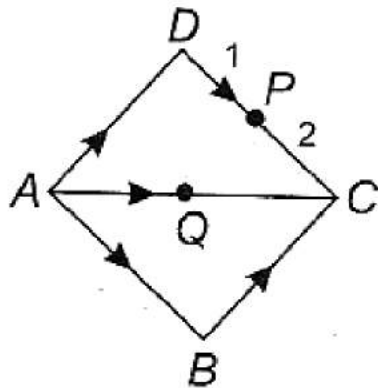

$$\begin{aligned}
&= 3AC - 4DC \\
&= 3(2QC) - 4\left(\frac{3}{2}PC\right) \\
&= 6QC - 6PC = 6(QC + CP) \\
&= kPQ = 6QP = -6PQ \quad (\text{given}) \\
\Rightarrow k &= -6
\end{aligned}$$

18. Given, $m_1 = |a_1| = \sqrt{2^2 + (-1)^2 + 1^2} = \sqrt{6}$
 $m_2 = |a_2| = \sqrt{3^2 + (-4)^2 + (-4)^2} = \sqrt{6}$
 $m_3 = |a_3| = \sqrt{1^2 + 1^2 + (-1)^2} = \sqrt{3}$
and $m_4 = |a_4| = \sqrt{(-1)^2 + 3^2 + 1^2} = \sqrt{11}$
 $\therefore m_3 < m_1 < m_4 < m_2$

19. Let $a = i + 2j - k$, $b = i + j + k$
and $c = i - j + \lambda k$

Since, volume of tetrahedron $= \frac{1}{6} [abc]$

$$\Rightarrow \frac{2}{3} = \frac{1}{6} \begin{vmatrix} 1 & 2 & -1 \\ 1 & 1 & 1 \\ 1 & -1 & \lambda \end{vmatrix}$$

$$\Rightarrow 4 = -\lambda + 5$$

$$\Rightarrow \lambda = 1$$

20. Given, $P(\bar{A} \cup \bar{B}) = P(\overline{A \cap B}) = \frac{7}{10}$

Since, $P(A \cap B) + P(\overline{A \cap B}) = \frac{1}{3}$

$$\Rightarrow P(A \cap B) = 1 - \frac{7}{10} = \frac{3}{10}$$

$$\text{Also, } P(A \cup B) = P(A) + P(B) - P(A \cap B)$$

$$\Rightarrow \frac{4}{5} = P(A) + \frac{2}{5} - \frac{3}{10}$$

$$\begin{aligned}\Rightarrow P(A) &= \frac{4}{5} - \frac{2}{5} + \frac{3}{10} \\ &= \frac{2}{5} + \frac{3}{10} = \frac{7}{10}\end{aligned}$$

21. Here, $n = 6$

According to the question

$${}^6C_2 p^2 q^4 = 4 \cdot {}^6C_4 p^4 q^2$$

$$\Rightarrow q^2 = 4p^2$$

$$\Rightarrow (1-p)^2 = 4p^2$$

$$\Rightarrow 3p^2 + 2p - 1 = 0$$

$$\Rightarrow (p+1)(3p-1) = 0$$

$$\Rightarrow p = \frac{1}{3}$$

(\because p cannot be negative)

22. Since, given lines are parallel.

$$\therefore d = \frac{15-5}{4^2+3^2} = \frac{10}{5}$$

$$\Rightarrow d = 2 = \text{diameter of the circle}$$

$$\therefore \text{Radius of circle} = 1$$

$$\therefore \text{Area of circle} = \pi r^2 = \pi \text{ sq unit}$$

23. Let point (x_1, y_1) be on the line $3x + 4y = 5$.

$$3x_1 + 4y_1 = 5 \quad \dots\dots\dots (i)$$

$$\text{Also, } (x_1 - 1)^2 + (y_1 - 2)^2 = (x_1 - 3)^2 + (y_1 - 4)^2$$

$$\begin{aligned} \Rightarrow x_1 + y_1^2 - 2x_1 - 4y_1 + 5 \\ = x_1^2 + y_1^2 - 6x_1 - 8y_1 + 25 \quad \dots\dots\dots (ii) \end{aligned}$$

$$\Rightarrow 4x_1 + 4y_1 = 20 \quad \dots\dots\dots (iii)$$

On solving Eqs. (i) and (ii), we get, $x_1 = 15, y_1 = -10$

24. The point of intersection of lines

$$x + 3y - 1 = 0 \text{ and } X - 2y + 4 = 0 \text{ is } (-2, 1).$$

Let equation of line perpendicular to the given line is

$$2x - 3y + \lambda = 0.$$

Since, it passes through $(-2, 1)$.

$$\therefore 2(-2) - 3(1) + \lambda = 0$$

$$\Rightarrow \lambda = 7$$

$$\therefore \text{Required line is } 2x - 3y + 7 = 0$$

25. Given equation is

$$2x^2 - 10xy + 12y^2 + 5x + \lambda y - 3 = 0$$

$$\text{Here, } a = 2, h = -5, b = 12, g = \frac{5}{2}, f = \frac{\lambda}{2}, c = -3$$

$$\text{For pair of lines } \begin{vmatrix} a & h & g \\ h & b & f \\ g & f & c \end{vmatrix} = 0$$

$$\Rightarrow \begin{vmatrix} 2 & -5 & 5/2 \\ -5 & 12 & \lambda/2 \\ 5/3 & \lambda/2 & -3 \end{vmatrix} = 0$$

$$\Rightarrow 2 - 36 - \frac{\lambda^2}{4} + 5 \cdot 15 - \frac{5\lambda}{4}$$

$$+ \frac{5}{2} \cdot \frac{-5\lambda}{2} - 30 = 0$$

$$\Rightarrow -72 - \frac{\lambda^2}{2} + 75 - \frac{25\lambda}{4} - \frac{25\lambda}{4} - 75 = 0$$

$$\Rightarrow \lambda^2 + 25\lambda + 144 = 0$$

$$\Rightarrow \lambda + 9 \quad \lambda + 16 = 0$$

$$\Rightarrow \lambda = -9 \quad \because \lambda < 16$$

26. Given, $x^2 - 2xy - xy + 2y^2 = 0$

$$\Rightarrow (x - 2y)(x - y) = 0$$

$$\Rightarrow x = 2y, x = y \quad \dots\dots\dots (i)$$

Also, $x + y + 1 = 0 \quad \dots\dots\dots (ii)$

On solving Eqs. (i) and (ii), we get

A $-\frac{2}{3}, -\frac{1}{3}$ B $-\frac{1}{2}, -\frac{1}{2}$, C 0, 0

$$\therefore \text{Area of } \Delta ABC = \frac{1}{2} \begin{vmatrix} -\frac{2}{3} & -\frac{1}{3} & 1 \\ -\frac{1}{2} & -\frac{1}{2} & 1 \\ 0 & 0 & 1 \end{vmatrix}$$

$$= \frac{1}{2} \left[\frac{1}{3} - \frac{1}{6} \right] = \frac{1}{2} \cdot \frac{1}{6} = \frac{1}{12}$$

27. Given pair of lines are $x^2 - 3xy + 2y^2 = 0$

and $x^2 - 3xy + 2y^2 + x - 2 = 0$

$$\therefore (x - 2y)(x - y) = 0$$

And $(x - 2y + 2)(x - y - 1) = 0$

$$\Rightarrow x - 2y = 0, x - y = 0 \text{ and } x - 2y + 2 = 0,$$

$$x - y - 1 = 0$$

Since, the lines $x - 2y = 0$, $x - 2y + 2 = 0$ and $x - y = 0$, $x - y - 1 = 0$ are parallel.

Also, angle between $x - 2y = 0$ and $x - y = 0$ is not 90° .

\therefore It is a parallelogram.

28. In $\triangle OAC$,

$$OC^2 = 2^2 + 4^2 = 20$$

\therefore Required equation of circle is

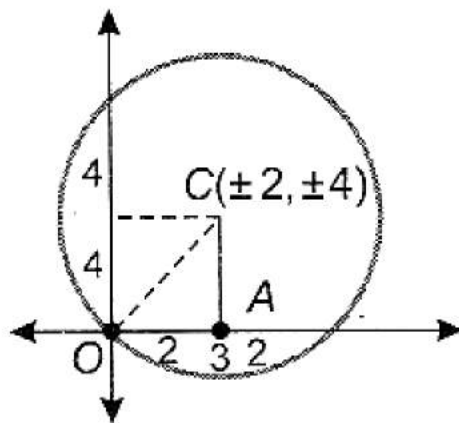

$$(x \pm 2)^2 + (y \pm 4)^2 = 20$$

$$\Rightarrow x^2 + y^2 \pm 4x \pm 8y = 0$$

29. Let centre of circle be $C(-g, -f)$, then equation of circle passing through origin be

$$x^2 + y^2 + 2gx + 2fy = 0$$

$$\therefore \text{Distance, } d = |-g - 3| = g + 3$$

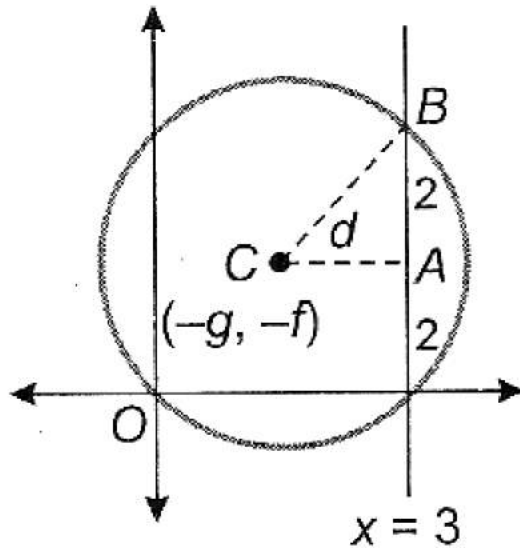

In ΔABC , $(BC)^2 = AC^2 + BA^2$

$$\Rightarrow g^2 + f^2 = (g + 3)^2 + 2^2$$

$$\Rightarrow g^2 + f^2 = g^2 + 6g + 9 + 4$$

$$\Rightarrow f^2 = 6g + 13$$

Hence, required locus is $y^2 + 6x = 13$

30. Given circles are $x^2 + y^2 - 2x + 8y + 13 = 0$ and $x^2 + y^2 - 4x + 6y + 11 = 0$.

Here, $C_1 = (1, -4)$, $C_2 = (2, -3)$,

$$\Rightarrow r_1 = \sqrt{1 + 16 - 13} = 2$$

and $r_2 = \sqrt{4 + 9 - 11} = \sqrt{2}$

$$\text{Now, } d = C_1C_2 = \sqrt{2 - 1^2 + -3 + 4^2} = \sqrt{2}$$

$$\therefore \cos \theta = \frac{d^2 - r_1^2 - r_2^2}{2r_1r_2} = \frac{2 - 4 - 2}{2 \times 2 \times \sqrt{2}} = -\frac{1}{\sqrt{2}}$$

$$\Rightarrow \theta = 135^\circ$$

31. Let the required equation of circle be $x^2 + y^2 + 2gx + 2fy = 0$.

Since, the above circle cuts the given circles orthogonally.

$$\therefore 2(-3g) + 2f(0) = 8 \Rightarrow 2g = -\frac{8}{3}$$

$$\text{And } -2g - 2f = -7$$

$$\Rightarrow 2f = +7 + \frac{8}{3} = \frac{29}{3}$$

\therefore Required equation of circle is

$$x^2 + y^2 - \frac{8}{3}x + \frac{29}{3}y = 0$$

$$\text{Or } 3x^2 + 3y^2 - 8x + 29y = 0$$

33. Given,

$$x^2y^2 = c^4$$

$$\Rightarrow y^2(a^2 - y^2) = c^4$$

$$\Rightarrow y^4 - a^2y^2 + c^4 = 0$$

Let $y_1 + y_2 + y_3$ and y_4 are the roots.

$$\therefore y_1 + y_2 + y_3 + y_4 = 0$$

34. Given, $4x - 3y = 5$ and $2x^2 - 3y^2 = 12$

$$\therefore 2 \left(\frac{5+3y}{4} \right)^2 - 3y^2 = 12$$

$$\Rightarrow \frac{25+9y^2+30y}{8} - 3y^2 = 12$$

$$\Rightarrow 15y^2 - 30y + 71 = 0$$

$$\Rightarrow y = \frac{30 \pm \sqrt{900 - 4260}}{30}$$

$$= 1 \pm \frac{-3360}{30}$$

Also, $2x^2 - 3 \frac{4x-5}{3}^2 = 12$

$$\Rightarrow 10x^2 - 40x + 61 = 0$$

$$\Rightarrow x = \frac{40 \pm \sqrt{1600 - 4 \times 10 \times 61}}{2 \times 10}$$

$$= \frac{40 \pm \sqrt{-840}}{20}$$

$$= 2 \pm \frac{-840}{20}$$

\therefore Point are A $2 + \frac{-840}{20}, 1 + \frac{-3360}{30}$ and

B $2 - \frac{-840}{20}, 1 - \frac{-3360}{30}$.

\therefore Mid point of AB is (2, 1).

35. $\cos 2a + \cos 2\beta + \cos 2\gamma + \sin^2 a + \sin^2 \beta + \sin^2 \gamma$
 $= (\cos^2 a - \sin^2 a) + (\cos^2 \beta - \sin^2 \beta)$
 $+ (\cos^2 \gamma - \sin^2 \gamma) + \sin^2 a + \sin^2 \beta + \sin^2 \gamma$
 $= \cos^2 a + \cos^2 \beta + \cos^2 \gamma = 1$

36. We know that image (x, y, z) of a point (x₁, y₁, z₁) in a plane ax + by + cz + d = 0 is

$$\frac{x-x_1}{a} = \frac{y-y_1}{b} = \frac{z-z_1}{c}$$

$$= \frac{-2ax_1 + by_1 + cz_1 + d}{a^2 + b^2 + c^2}$$

Here, point is (3, 2, 1) and plane is 2x - y + 3z = 7.

$$\therefore \frac{x-3}{2} = \frac{y-2}{-1} = \frac{z-1}{3}$$

$$= \frac{-2 \cdot 2 \cdot 3 - 2 + 3 \cdot 1 - 7}{2^2 + 1^2 + 3^2}$$

$$\Rightarrow \frac{x-3}{2} = \frac{y-2}{-1} = \frac{z-1}{3} = -2 \cdot 0$$

$$\Rightarrow x = 3, y = 2, z = 1$$

$$37. \lim_{x \rightarrow \infty} \frac{x+5}{x+2}^{x+3} = \lim_{x \rightarrow \infty} 1 + \frac{3}{x+2}^{x+3}$$

$$= \lim_{x \rightarrow \infty} 1 + \frac{3}{x+2}^{\frac{x+2}{3} \cdot \frac{3}{x+2} \cdot (x+3)}$$

$$= e^{\lim_{x \rightarrow \infty} 3 \cdot \frac{1+\frac{3}{x}}{1+\frac{2}{x}}} = e^3$$

$$38. \text{ Given, } f(x) = \begin{cases} \frac{2 \sin x - \sin 2x}{2x \cos x} & \text{if } x \neq 0 \\ a & \text{if } x = 0 \end{cases}$$

$$\text{Now, } \lim_{x \rightarrow 0} f(x) = \lim_{x \rightarrow 0} \frac{2 \sin x - \sin 2x}{2x \cos x} \quad \frac{0}{0} \text{ form}$$

$$= \lim_{x \rightarrow 0} \frac{2 \cos x - 2 \cos 2x}{2 \cos x - x \sin x}$$

$$= \lim_{x \rightarrow 0} \frac{2-2}{2 \cdot 1 - 0} = 0$$

Since, $f(x)$ is continuous at $x = 0$

$$\therefore f(0) = \lim_{x \rightarrow 0} f(x)$$

$$\Rightarrow a = 0$$

$$39. \text{ Given, } \frac{x}{1} = \frac{1 - \bar{y}}{1 + \bar{y}}$$

Applying componendo and dividendo, we get

$$\frac{1+x}{1-x} = \frac{1 + \bar{y} + 1 - \bar{y}}{1 + \bar{y} - 1 - \bar{y}}$$

$$\Rightarrow \frac{1+x}{1-x} = \frac{2}{2y}$$

$$\Rightarrow y = \frac{1-x}{1+x}^2$$

On differentiating w.r.t. x , we get

$$\begin{aligned} \frac{dy}{dx} &= \frac{-2 \frac{1+x}{1-x} \cdot \frac{1-x}{1+x} - \frac{1-x}{1+x} \cdot 2 \cdot \frac{1+x}{1-x}}{1+x^2} \\ &= \frac{1-x}{1+x} \cdot \frac{1+x}{1-x} \cdot \frac{-2-2x-2+2x}{1+x^2} \\ &= \frac{4x-1}{x-1}^3 \end{aligned}$$

40. Given, $\frac{d}{dx} a \tan^{-1} x + b \log \frac{x+1}{x-1} = \frac{1}{x^2-1}$

On integrating both sides, we get

$$\begin{aligned} a \tan^{-1} x + b \log \frac{x-1}{x+1} &= \int \frac{1}{x^2-1} - \frac{1}{x^2+1} dx \\ &= \frac{1}{2} \left(\frac{1}{x^2-1} - \frac{1}{x^2+1} \right) dx \\ \Rightarrow a \tan^{-1} x + b \log \frac{x-1}{x+1} &= \frac{1}{4} \log \frac{x-1}{x+1} - \frac{1}{2} \tan^{-1} x \\ \Rightarrow a &= -\frac{1}{2}, b = \frac{1}{4} \end{aligned}$$

$$\therefore a - 2b = -\frac{1}{2} - 2 \cdot \frac{1}{4} = -1$$

41. Given, $Y = e^{a \sin^{-1} x}$

On differentiating w.r.t. x , we get

$$y_1 = e^{a \sin^{-1} x} \cdot a \cdot \frac{1}{1-x^2}$$

$$\Rightarrow y_1 \overline{1-x^2} = ay$$

$$\Rightarrow 1 - x^2 y_1^2 = a^2 y^2$$

Again, differentiating w.r.t. x , we get

$$(1 - x^2)2y_1 y_2 - 2xy_1^2 = a^2 2yy_1$$

$$\Rightarrow (1 - x^2)y_2 - xy_1 - a^2 y = 0$$

Using Leibnitz's rule,

$$(1 - x^2)y_{n+2} + {}^n C_1 y_{n+1} (-2x) + {}^n C_2 y_n (-2)$$

$$-xy_{n+1} - {}^n C_1 y_n - a^2 y_n = 0$$

$$\Rightarrow (1 - x^2)y_{n+2} + xy_{n+1}(-2n - 1) + y_n[-n(n - 1) - n - a^2] = 0$$

$$\Rightarrow (1 - x^2)y_{n+2} - (2n + 1)xy_{n+1} = (n^2 + a^2)y_n$$

42. Given, $f(x) = x^3 + ax^2 + bx + c$, $a^2 \leq 3b$.

On differentiating w.r.t. x , we get

$$f'(x) = 3x^2 + 2ax + b$$

Put $f'(x) = 0$

$$\Rightarrow 3x^2 + 2ax + b = 0$$

$$\Rightarrow x = \frac{-2a \pm \sqrt{4a^2 - 12b}}{2 \times 3} = \frac{-2a \pm \sqrt{a^2 - 3b}}{3}$$

Since, $a^2 \leq 3b$,

$\therefore x$ has an imaginary value.

Hence; no extreme value of x exist.

43. Let $I = \frac{2 - \sin 2x}{1 - \cos 2x} e^x dx$

$$= \frac{2 - 2 \sin x \cos x}{2 \sin^2 x} e^x dx$$

$$\begin{aligned}
 &= \operatorname{cosec}^2 x e^x dx - \cot x e^x dx \\
 &= -\cot x e^x - \cot x e^x dx \\
 &\quad - \cot x e^x dx + c \\
 &= -\cot x e^x + c
 \end{aligned}$$

44. Let $I = \int_0^{\pi} \frac{1}{1+\sin x} dx = \int_0^{\pi} \frac{1}{1 + \frac{2 \tan \frac{x}{2}}{1 + \tan^2 \frac{x}{2}}} dx$

$$= \int_0^{\pi} \frac{\sec^2 \frac{x}{2}}{1 + \tan^2 \frac{x}{2}} dx$$

Put $\tan \frac{x}{2} = t \Rightarrow \frac{1}{2} \sec^2 \frac{x}{2} dx = dt$

$$\therefore I = \int_0^{\infty} \frac{2 dt}{1+t^2} = -\frac{2}{1+t} \Big|_0^{\infty} = 2$$

45. Given, $\frac{dy}{dx} = \sin x + y \tan x + y - 1$

Put $x + y = z \Rightarrow 1 + \frac{dy}{dx} = \frac{dz}{dx}$

$$\therefore \frac{dz}{dx} - 1 = \sin z \tan z - 1$$

$$\Rightarrow \frac{\cos z}{\sin^2 z} dz = dx$$

Put $\sin z = t \Rightarrow \cos z dz = dt$

$$\therefore \frac{1}{t^2} dt = x - c \Rightarrow -\frac{1}{t} = x - c$$

$$\Rightarrow -\operatorname{cosec} z = x - c$$

$$\Rightarrow x + \operatorname{cosec} x + y = c$$

46. Given, $y = a \sin (bt - cx)$

Comparing the given equation with general wave equation

$$y = a \sin \frac{2\pi t}{T} - \frac{2\pi x}{\lambda}$$

we get $b = \frac{2\pi}{T}$, $c = \frac{2\pi}{\lambda}$

(a) Dimensions of $\frac{y}{a} = \frac{\text{metre}}{\text{metre}} = \frac{L}{L}$

(b) Dimensions of $bt = \frac{2\pi}{T} \cdot t = \frac{T}{T}$

(c) Dimensions of $cx = \frac{2\pi}{\lambda} \cdot x = \frac{L}{L}$

(d) Dimensions of $\frac{b}{c} = \frac{2\pi}{T} / \frac{2\pi}{\lambda} = \lambda/T = LT^{-1}$

Thus, option (d) has dimensions.

47. Let time taken by the body to fall from point C to B is t' .

Then $t_1 + 2t' = t_2$

$$t' = \frac{t_2 - t_1}{2} \quad \dots\dots (i)$$

Total time taken to reach point C

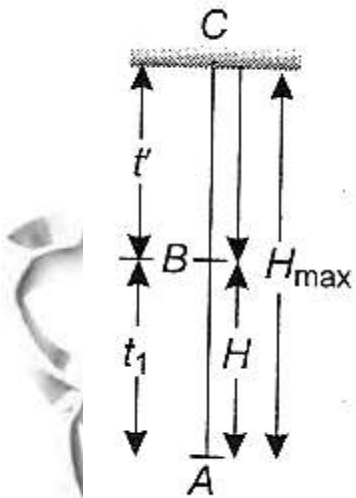

$$\begin{aligned} T &= t_1 + t' \\ &= t_1 + \frac{t_2 - t_1}{2} \end{aligned}$$

$$= \frac{2t_1 + t_2 - t_1}{2}$$

$$= \frac{t_1 + t_2}{2}$$

Maximum height attained

$$H_{\max} = \frac{1}{2} g T^2$$

$$= \frac{1}{2} g \left(\frac{t_1 + t_2}{2} \right)^2$$

$$= \frac{1}{2} g \cdot \frac{t_1^2 + t_2^2 + 2t_1 t_2}{4}$$

$$\Rightarrow H_{\max} = \frac{1}{8} g \cdot (t_1 + t_2)^2$$

48. Momentum, $p = m \cdot v$

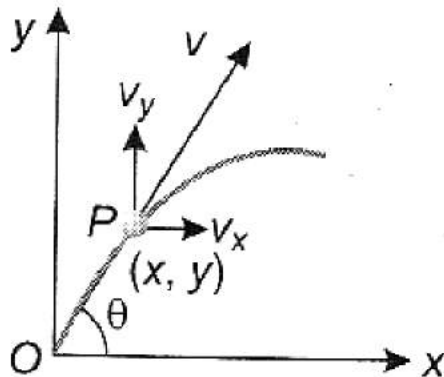

$$\Rightarrow v = \frac{p}{m}$$

$$\text{Kinetic energy, } KE = \frac{1}{2} m v^2$$

$$= \frac{1}{2} m \frac{p^2}{m^2} = \frac{1}{2m} p^2$$

$$\Rightarrow KE \propto p^2 \quad \because \frac{1}{2m} = \text{constant}$$

Hence, the graph between KE and p^2 will be linear as shown below

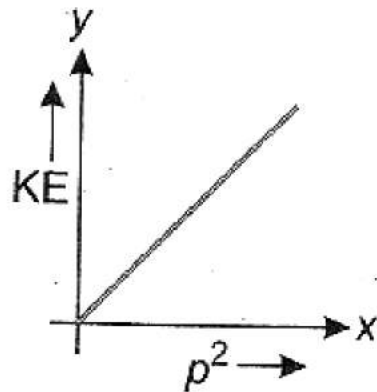

Now, Kinetic energy $KE = \frac{1}{2} mv^2$

The velocity component at point P,

$$v_y = (u \sin \theta - gt)$$

and $v_x = u \cos \theta$

Resultant velocity at point P,

$$v = v_y j + v_x i$$

$$= (u \sin \theta - gt) j + u \cos \theta i$$

$$v = \sqrt{u \cos^2 \theta + u \sin \theta - gt^2}$$

$$= \sqrt{u^2 \cos^2 \theta + u^2 \sin^2 \theta + g^2 t^2 - 2ugt \sin \theta}$$

$$\therefore v = \sqrt{u^2 \cos^2 \theta + \sin^2 \theta + g^2 t^2 - 2ugt \sin \theta}$$

$$KE = \frac{1}{2} m (u^2 + g^2 t^2 - 2ugt \sin \theta)$$

$$\Rightarrow KE \propto t^2$$

Hence, graph will be parabolic with intercept on y-axis.

Hence, the graph between KE and t

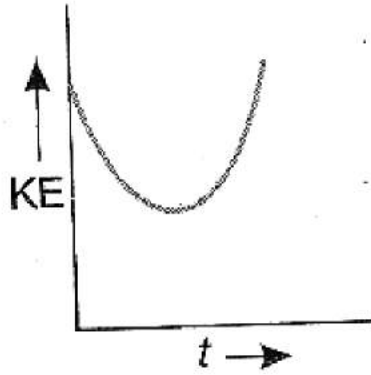

Now, in case of height

$$KE = \frac{1}{2} m(v^2)$$

and $v^2 = (u^2 - 2gy)$

$$\therefore KE = \frac{1}{2} m(u^2 - 2gy)$$

$$KE = -mgy + \frac{1}{2} mu^2$$

Intercept on y-axis = $\frac{1}{2} mu^2$

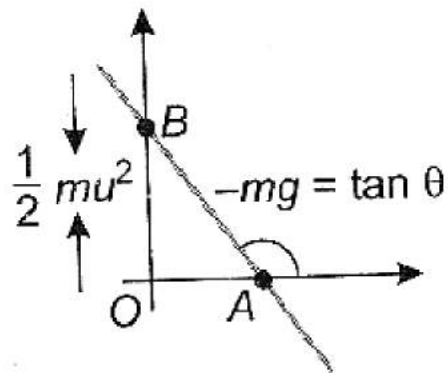

Now, $KE = \frac{1}{2} mv^2$

$$KE = \frac{1}{2} m \left(\frac{x}{t}\right)^2$$

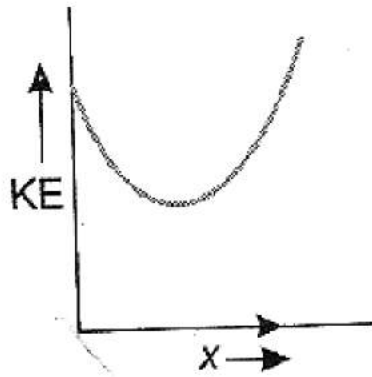

$KE \propto x^2$. Thus graph between KE and x will be parabolic.

49. Power of motor initially = P_0

Let, rate of flow of motor = (x)

$$\text{Since, power, } P_0 = \frac{\text{work}}{\text{time}} = \frac{mgy}{t}$$

$$= mg \frac{y}{t},$$

$$= \frac{y}{t} = x = \text{rate of flow of water}$$

$$= mgx \quad \dots\dots\dots (i)$$

If rate of flow of water is increased by n times, ie, (nx) .

$$\text{Increased power } P_1 = \frac{mgy'}{t}$$

$$= mg \frac{y'}{t}$$

$$= mgn.x \quad \dots\dots\dots (ii)$$

$$= nmgx$$

The ratio of power

$$\frac{P_1}{P_0} = \frac{nmgx}{mgx}$$

$$\frac{P_1}{P_0} = \frac{n}{1} \Rightarrow P_1 : P_0 = n : 1$$

50. Mass of the first body $m_1 = 5 \text{ kg}$, for elastic collision $e = 1$.

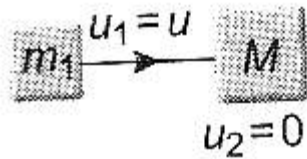

Suppose initially body m_1 moves with velocity u after collision velocity becomes $\frac{u}{10}$.

Let after collision velocity of M block becomes (v_2).

By conservation of momentum

$$m_1 u_1 + m_2 u_2 = m_1 v_1 + m_2 v_2$$

$$\text{or } 5u + M \times 0 = 5 \times \frac{u}{10} + Mv_2$$

$$\text{or } 5u = \frac{u}{2} + Mv_2 \quad \dots\dots\dots (i)$$

Since, $v_1 - v_2 = -e(u_1 - u_2)$

$$\frac{u}{10} - v_2 = -u$$

$$\text{Or } \frac{u}{10} + u = v_2$$

$$\frac{11u}{10} = v_2$$

Substituting value of v_2 in Eq. (i) from Eq. (ii). we get

$$5u = \frac{u}{2} + M \frac{11u}{10}$$

$$\text{Or } 5 - \frac{1}{2} = M \frac{11}{10}$$

$$\text{Or } M = \frac{9 \times 10}{2 \times 11}$$

$$\text{Or } M = \frac{45}{11} = 4.09 \text{ kg}$$

51.

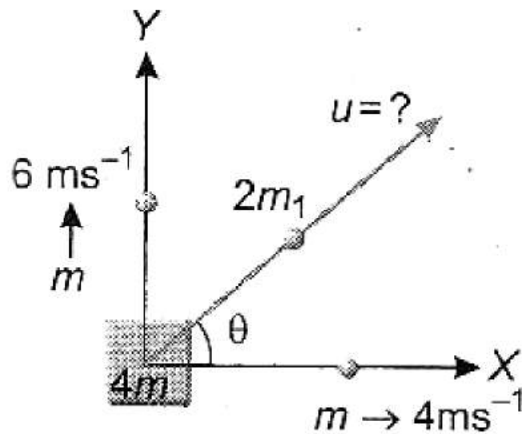

Let third mass particle ($2m$) moves making angle θ with X-axis.

The horizontal component of velocity of $2m$ mass particle = $u \cos \theta$ and vertical component = $u \sin \theta$

From conservation of linear momentum in X-direction

$$m_1 u_1 + m_2 u_2 = m_1 v_1 + m_2 v_2$$

or $0 = m \times 4 + 2m (u \cos \theta)$

or $-4 = 2u \cos \theta$

or $-2 = u \cos \theta$ (i)

Again, applying law of conservation of linear momentum in y-direction.

$$0 = m \times 6 + 2m(u \sin \theta)$$

$\Rightarrow -\frac{6}{2} = u \sin \theta$

or $-3 = u \sin \theta$ (ii)

Squaring Eqs. (i) and (ii) and adding, we get

$$\begin{aligned} (4) + (9) &= u^2 \cos^2 \theta + u^2 \sin^2 \theta \\ &= u^2 (\cos^2 \theta + \sin^2 \theta) \end{aligned}$$

or $13 = u^2$

or $u = \sqrt{13} \text{ ms}^{-1}$

52. Maximum height attained by a projectile

$$h = \frac{v^2 R}{2gR - v^2} \dots\dots\dots (i)$$

Velocity of body = half the escape velocity

$$v = \frac{v_e}{2}$$

Or $v = \frac{\sqrt{2gR}}{2} \Rightarrow v^2 = \frac{2gR}{4}$

Or $v^2 = \frac{gR}{2}$

Now, putting value of v^2 in Eq. (i), we get

$$h = \frac{\frac{gR}{2} \cdot R}{2gR - \frac{gR}{2}}$$
$$= \frac{gR^2/R}{3gR/2}$$

Or $h = \frac{R}{3}$

53. The displacement of particle, executing SHM is

$$y = 5 \sin \left(4t + \frac{\pi}{3} \right) \dots\dots\dots (i)$$

Velocity of particle

$$\frac{dy}{dt} = \frac{5d}{dt} \sin \left(4t + \frac{\pi}{3} \right)$$

$$= 5 \cos \left(4t + \frac{\pi}{3} \right)$$

$$= 20 \cos \left(4t + \frac{\pi}{3} \right)$$

Velocity at $t = \frac{T}{4}$

$$\frac{dy}{dt} \Big|_{t=\frac{T}{4}} = 20 \cos \left(4 \times \frac{T}{4} + \frac{\pi}{3} \right)$$

Or $u = 20 \cos \left(T + \frac{\pi}{3} \right)$ (ii)

Now, putting value of T in Eq. (ii), we get

$$\begin{aligned} u &= 20 \cos \left(\frac{\pi}{2} + \frac{\pi}{3} \right) \\ &= -20 \sin \frac{\pi}{3} \\ &= -20 \times \frac{\sqrt{3}}{2} \\ &= -10 \times \sqrt{3} \end{aligned}$$

The kinetic energy of particle,

$$KE = \frac{1}{2} mu^2$$

$$\begin{aligned} \because m &= 2g = 2 \times 10^{-3} \text{ kg} \\ &= \frac{1}{2} \times 2 \times 10^{-3} \times (-10\sqrt{3})^2 \\ &= 10^{-3} \times 100 \times 3 \\ &= 3 \times 10^{-1} \end{aligned}$$

$$KE = 0.3 \text{ J}$$

54. Free body diagram of the two blocks are

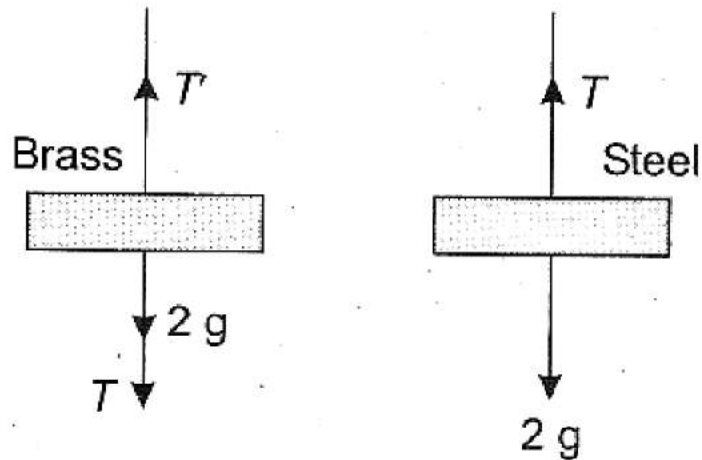

Given, $\frac{l_1}{l_2} = a, \frac{r_1}{r_2} = b, \frac{Y_1}{Y_2}$

Let Young's modulus of steel is Y_1 and of brass is Y_2 .

$\therefore Y_1 = \frac{F_1 \cdot l_1}{A_1 \cdot \Delta l_1}$ (i)

And $Y_2 = \frac{F_2 \cdot l_2}{A_2 \cdot \Delta l_2}$ (ii)

Dividing Eq. (i) by Eq. (ii), we get

$$\frac{Y_1}{Y_2} = \frac{\frac{F_1 l_1}{A_1 \Delta l_1}}{\frac{F_2 l_2}{A_2 \Delta l_2}}$$

Or $\frac{Y_1}{Y_2} = \frac{F_1 \cdot A_2 \cdot l_1 \cdot \Delta l_2}{F_2 \cdot A_1 \cdot l_2 \cdot \Delta l_1}$ (iii)

Force on steel wire from free body diagram

$$T = F_1 = (2g) \text{ newton}$$

Force on brass wire from free body diagram

$$F_2 = T' = T + 2g = (4g) \text{ newton}$$

Now, putting the value of F_1, F_2 , in Eq. (iii), we get

$$\frac{Y_1}{Y_2} = \frac{2g}{4g} \cdot \frac{\pi r_2^2}{\pi r_1^2} \cdot \frac{l_2}{l_1} \cdot \frac{\Delta l_2}{\Delta l_1}$$

$$\text{Or } c = \frac{1}{2} \cdot \frac{1}{b^2} \cdot a \cdot \frac{\Delta l_2}{\Delta l_1}$$

$$\text{Or } \frac{\Delta l_1}{\Delta l_2} = \frac{a}{2b^2 c}$$

55. Initially area of soap bubble $A_1 = 4\pi r^2$

Under isothermal condition radius becomes $2r$,

$$\begin{aligned} \text{Then, area } A_2 &= 4\pi(2r)^2 \\ &= 4\pi \cdot 4r^2 \\ &= 16\pi r^2 \end{aligned}$$

Increase in surface area

$$\begin{aligned} \Delta A &= 2(A_2 - A_1) \\ &= 2(16\pi r^2 - 4\pi r^2) \\ &= 24\pi r^2 \end{aligned}$$

Energy spent

$$\begin{aligned} W &= T \times \Delta A \\ &= T \cdot 24\pi r^2 \end{aligned}$$

or $W = 24\pi T r^2 \text{ J}$

56. Let now radius of big drop is R .

$$\text{Then } \frac{4}{3} \pi R^3 = \frac{4}{3} \times \pi r^3 \cdot 8$$

$$R = 2r$$

where r is radius of small drops. Now, terminal velocity of drop in liquid.

$$v_e = \frac{2}{9} \times \frac{r^2}{\eta} (\rho - \sigma) g$$

where η is coefficient of viscosity and ρ is density of drop σ is density of liquid.

Terminal speed drop is 6 cm s^{-1}

$$\therefore 6 = \frac{2}{9} \times \frac{r^2}{\eta} \rho - \sigma g \quad \dots\dots\dots (i)$$

Let terminal velocity becomes v' after coalesce, then

$$v' = \frac{2}{9} \frac{R^2}{\eta} \rho - \sigma g \quad \dots\dots\dots (ii)$$

Dividing Eq. (i) by Eq. (ii), we get

$$\frac{6}{v'} = \frac{\frac{2r^2}{9\eta} \rho - \sigma g}{\frac{2R^2}{9\eta} \rho - \sigma g}$$

$$\text{Or } \frac{6}{v'} = \frac{r^2}{2r^2}$$

$$\text{Or } v' = 24 \text{ cm s}^{-1}$$

57. Time period of oscillation,

$$T = 2\pi \sqrt{\frac{l}{g}}$$

$$\Rightarrow \frac{dT}{T} = \frac{1}{2} \frac{dl}{l}$$

$$\text{As, } \frac{dl}{l} = a dt$$

$$\Rightarrow \frac{dT}{T} = \frac{1}{2} a dt$$

$$= \frac{1}{2} \times 9 \times 10^{-7} \times 30 - 20$$

$$= 4.5 \times 10^{-6}$$

$$\therefore \text{Loss in time} = 4.5 \times 10^{-6} \times 0.5$$

$$= 2.25 \times 10^{-6} \text{ s}$$

58. The volume of the metal at 30°C is

$$V_{30} = \frac{\text{loss of weight}}{\text{specific gravity} \times g}$$
$$= \frac{45-25 \text{ g}}{1.5 \times g} = 13.33 \text{ cm}^3$$

Similarly, volume of metal at 40°C is

$$V_{40} = \frac{40-27 \text{ g}}{1.25 \times g}$$
$$= 14.40 \text{ cm}^3$$

Now, $V_{40} = V_{30} [1 + \gamma (t_2 - t_1)]$

Or $\gamma = \frac{V_{40} - V_{30}}{V_{30} (t_2 - t_1)}$

$$= \frac{14.40 - 13.33}{13.33 (40 - 30)}$$
$$= 8.03 \times 10^{-3} / ^\circ\text{C}$$

∴ Coefficient of linear expansion of the metal is

$$a = \frac{\gamma}{3} = \frac{8.03 \times 10^{-3}}{3}$$
$$\approx 2.6 \times 10^{-3} / ^\circ\text{C}$$

59. A → B → C → D → A is clockwise process.

During A → B, pressure is constant and B → C, process follows $p \propto \frac{1}{V}$, it means T is constant.

During process C → D, both p and V changes and process D → A follows $p \propto \frac{1}{V}$ which means T is constant:

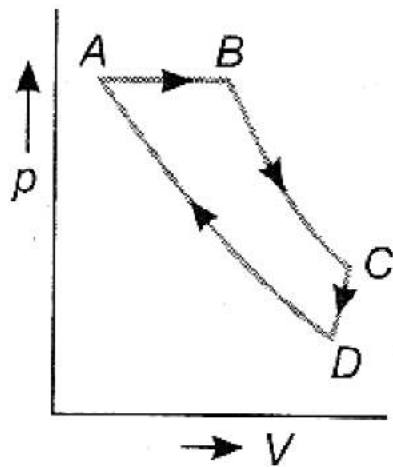

Hence, from above data it is clear that equivalent cyclic process is

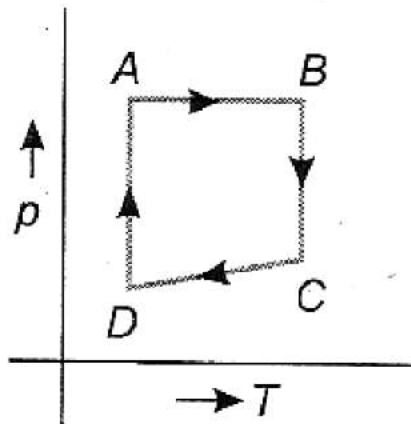

60. From first law of thermodynamics

$$Q = \Delta U + W$$

or $\Delta U = Q - W$

$$\therefore \Delta U_1 = Q_1 - W_1 = 6000 - 2500 = 3500 \text{ J}$$

$$\Delta U_2 = Q_1 - W_2 = -5500 + 1000 = -4500 \text{ J}$$

$$\Delta U_3 = Q_3 - W_3 = -3000 + 1200 = -1800 \text{ J}$$

$$\Delta U_4 = Q_4 - W_4 = 3500 - x = 0$$

For cyclic process $\Delta U = 0$

$$\therefore 3500 - 4500 - 1800 + 3500 - x = 0$$

$$\text{or } x = 700 \text{ J}$$

$$\text{Efficiency, } \eta = \frac{\text{output}}{\text{input}} \times 100$$

$$= \frac{W_1 + W_2 + W_3 + W_4}{Q_1 + Q_4} \times 100$$

$$= \frac{2500 - 1000 - 1200 + 700}{6000 + 3500} \times 100$$

$$= \frac{1000}{9500} \times 100$$

$$\eta = 10.5\%$$

61. From first law of thermodynamics

$$Q = \Delta U + W$$

For cylinder A pressure remains constant

\therefore Work done by a system

$$W = \frac{\mu R}{\gamma - 1} T_1 - T_2$$

For monatomic gases

$$\mu = 1$$

$$\gamma = \frac{5}{3}$$

$$\therefore W = \frac{1 \times R}{5} 442 - 400 = \frac{3}{2} R \times 42$$

$$\text{or } W = 63R$$

But $\Delta U = 0$, for cylinder A

$$Q = 0 + 63R$$

$$Q = 63R$$

For cylinder B volume is constant,

$$\therefore W = 0$$

and $Q = \mu C_v \Delta T$

For mono atomic gas

$$C_v = \frac{3}{2} R$$

$$Q = 1 \times \frac{3}{2} R \Delta T$$

As heat given to both cylinder is same

$$\therefore 63R = \frac{3}{2} R \Delta T$$

$$\Delta T = 42K$$

62. According to the figure

$$H = H_1 + H_2$$

$$\Rightarrow \frac{3KA}{l} \frac{100-T}{l} = \frac{2KA}{l} \frac{T-50}{l} + \frac{KA}{l} \frac{T-0}{l}$$

$$300 - 3T = 2T - 100 + T$$

$$\Rightarrow 6T = 400$$

$$\text{Or } T = \frac{200}{3} \text{ } ^\circ\text{C}$$

63. Listener go from A \rightarrow B with velocity (u) let the apparent frequency of sound from source A by listener



$$n' = n \frac{v - v_0}{v + v_s}$$

or $n' = 680 \frac{340 - u}{340 + 0}$

The apparent frequency of sound from source B by listener

$$n'' = n \frac{v + v_0}{v - v_s} = 680 \frac{340 + u}{340 - 0}$$

But listener hear 10 beats per second.

Or $680 \frac{340 + u}{340} - 680 \frac{340 - u}{340} = 10$

Or $2 \frac{340 + u - 340 + u}{340} = 10$

$$u = 2.5 \text{ m s}^{-1}$$

64. Beats per second when both the wires vibrate simultaneously.

$$n_1 \pm n_2 = 6$$

or $\frac{1}{2l} \frac{T}{m} \pm \frac{1}{2l} \frac{T'}{m} = 6$

or $\frac{1}{2l} \frac{T'}{m} - \frac{1}{2l} \frac{T}{m} = 6$

or $\frac{1}{2l} \frac{T'}{m} - 600 = 6$

$$\frac{1}{2l} \frac{T'}{m} = 606$$

..... (i)

Given that fundamental frequency

$$\frac{1}{2l} \frac{\bar{T}}{m} = 600 \quad \dots\dots\dots (ii)$$

Dividing Eq.(i) by Eq. (ii), we get

$$\frac{\frac{1}{2l} \frac{\bar{T}'}{m}}{\frac{1}{2l} \frac{\bar{T}}{m}} = \frac{606}{600}$$

Or $\frac{\bar{T}'}{\bar{T}} = 1.01$

Or $\frac{T'}{T} = 1.02 \%$

Or $T' = T 1.02$

Increase in tension

$$\begin{aligned} \Delta T' &= T \times 1.02 - T \\ &= 0.02T \end{aligned}$$

Hence, $\Delta T' = 0.02$

65.

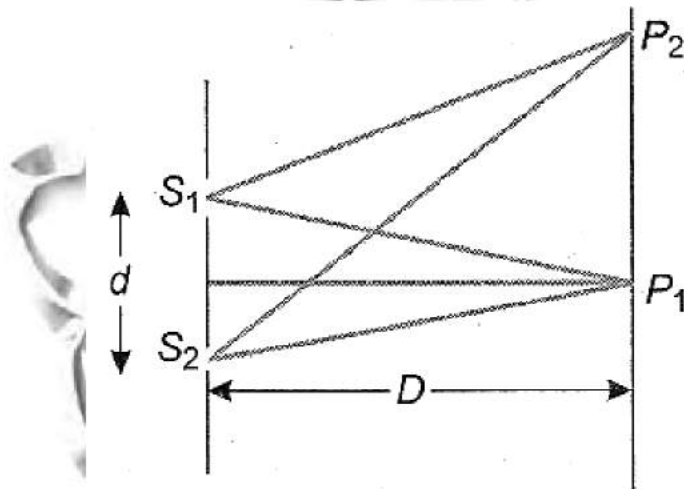

Fringe width $\beta = \frac{\lambda D}{d}$

Let the amplitude of that place where constructive interference takes place is a.

The position of fringe at p_2 is

$$x = \frac{n\lambda D}{d}$$

Given, $\beta = \frac{\beta}{4}$

$$\therefore \frac{\lambda D}{4d} = \frac{n\lambda D}{d}$$

or $n = \frac{1}{4}$

$$\therefore \frac{I_1}{I_2} = \frac{a^2}{\frac{a}{4}^2}$$

Or $I_1 : I_2 = 16 : 1$

66. Position fringe from central maxima

$$y_1 = \frac{n\lambda_1 D}{d}$$

Given, $n = 10$

$$\therefore y_1 = \frac{10\lambda_1 D}{d} \dots\dots\dots (i)$$

For second source

$$y_2 = \frac{5\lambda_2 D}{d} \dots\dots\dots (ii)$$

$$\therefore \frac{y_1}{y_2} = \frac{\frac{10\lambda_1 D}{d}}{\frac{5\lambda_2 D}{d}}$$

$$\Rightarrow \frac{y_1}{y_2} = \frac{2\lambda_1}{\lambda_2}$$

67. Interference phenomenon takes place between two waves which www.exampape.com

have equal frequency and propagate in same direction.

$$\text{Hence, } y_1 = a \sin (\omega t + \phi)_1$$

$$y_3 = a' \sin (\omega t + \phi_2)$$

will give rise to interference as the two waves have same frequency ω .

68. The two lenses of an achromatic doublet should have, sum of the product of their powers and dispersive power equal to zero.

69. Ratio of magnetic moments of two magnets of equal size when in sum and difference position is

$$\frac{M_A}{M_B} = \frac{T_d^2 + T_s^2}{T_d^2 - T_s^2} = \frac{v_s^2 + v_d^2}{v_s^2 - v_d^2}$$

$$= \frac{\frac{1}{20}^2 + \frac{1}{15}^2}{\frac{1}{15}^2 - \frac{1}{20}^2}$$

$$= \frac{400 + 225}{400 - 225}$$

$$\Rightarrow M_A : M_B = 25 : 7$$

70. Length of magnet = 10 cm = 10×10^{-2} m,

$$r = 15 \times 10^{-2} \text{ m}$$

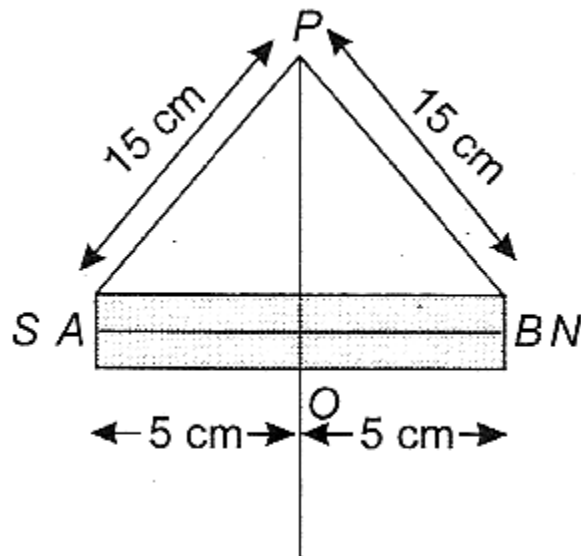

$$OP = \sqrt{225 - 25} = \sqrt{200} \text{ cm}$$

Since, at the neutral point, magnetic field due to the magnet is equal to B_H

$$B_H = \frac{\mu_0}{4\pi} \cdot \frac{M}{OP^2 + AO^2} \cdot \frac{1}{3/2}$$

$$0.4 \times 10^{-4} = 10^{-7} \times \frac{M}{200 \times 10^{-4} + 25 \times 10^{-4}} \cdot \frac{2}{3}$$

$$\frac{0.4 \times 10^{-4}}{10^{-7}} \times \frac{3}{2} \times 225 \times 10^{-4} = M$$

$$0.4 \times 10^3 \times 10^{-6} \times 225 \cdot \frac{3}{2} = M$$

$$M = 1.35 \text{ A-m}$$

71. Charge density of long wire

$$\lambda = \frac{1}{3} \text{ C-m}$$

And $r = 18 \times 10^{-2} \text{ m}$

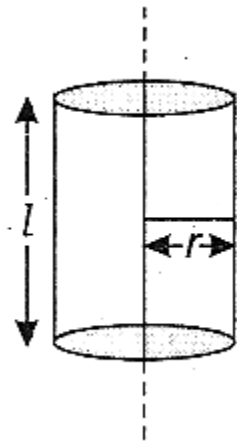

From Gauss theorem

$$E \cdot dS = \frac{q}{\epsilon_0}$$

$$E \cdot dS = \frac{q}{\epsilon_0}$$

or $E \times 2\pi r l = \frac{q}{\epsilon_0}$

or $E = \frac{q}{2\pi\epsilon_0 r l} = \frac{q/l}{2\pi\epsilon_0 r}$

$$= \frac{\lambda \times 2}{2\pi\epsilon_0 r \times 2} = \frac{\lambda \times 2}{4\pi\epsilon_0 r}$$

$$= 9 \times 10^9 \times \frac{1}{3} \times 2 \times \frac{1}{18 \times 10^{-2}}$$

$$= \frac{1}{3} \times 10^{11} = 0.33 \times 10^{11}$$

$$= 0.33 \times 10^{11} \text{ NC}^{-1}$$

72. Potential at P due to (+q) charge

$$V_1 = \frac{1}{4\pi\epsilon_0} \cdot \frac{q}{z-a}$$

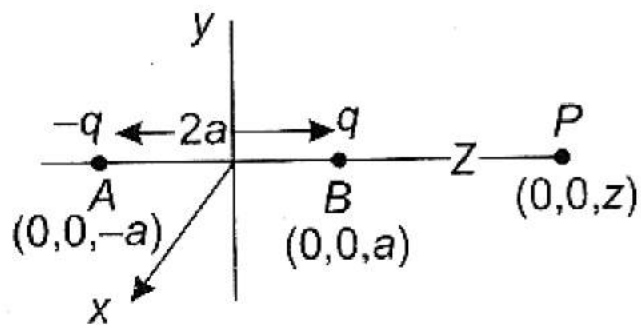

Potential at P due to (-q) charge

$$V_2 = \frac{1}{4\pi\epsilon_0} \cdot \frac{-q}{z+a}$$

Total potential at P due to (AB) electric dipole

$$V = V_1 + V_2$$

$$= \frac{1}{4\pi\epsilon_0} \cdot \frac{q}{z-a} - \frac{1}{4\pi\epsilon_0} \cdot \frac{q}{z+a}$$

$$= \frac{q}{4\pi\epsilon_0} \cdot \frac{z-a-z+a}{z-a} \cdot \frac{1}{z+a}$$

$$\Rightarrow V = \frac{2qa}{4\pi\epsilon_0 z^2 - a^2}$$

73.

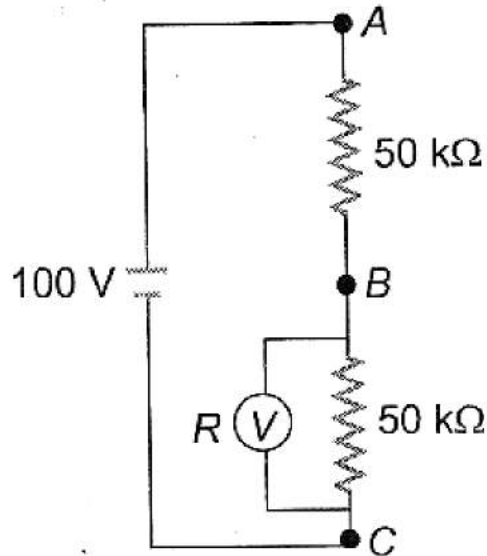

Internal resistance of voltmeter is R.

Therefore effective resistance across B and C, R' is given by

$$\frac{1}{R'} = \frac{1}{R} + \frac{1}{50} = \frac{50+R}{50R}$$

Or $R' = \frac{50R}{50+R}$

According to Ohm's law

$$V' = IR'$$

or $\frac{100}{3} = I \cdot \frac{50R}{50+R}$

or $\frac{100}{3} \cdot \frac{50+R}{50R} = I$

Now, total resistance of circuit

$$R'' = 50 + \frac{50R}{50+R}$$

Or $R'' = \frac{2500+100R}{50+R}$

Now, $V'' = IR''$

$$\Rightarrow 100 = \frac{100}{3} \cdot \frac{50+R}{50R} \cdot \frac{2500+100R}{50+R}$$

or $150R = 2500 + 100R$

or $50R = 2500$

or $R = 50 \text{ k}\Omega$

74. Resistance of potentiometer wire

$$R = \rho \times \frac{l}{A}$$

Or $R' = \frac{2.5\rho}{A \times 10}$

Potential $V' = I \times R'$

$$= I \frac{2.5\rho}{A \times 10}$$

Now, again the length of potentiometer wire is increased by 1 m, then resistance of null position wire.

$$R'' = \frac{\rho \times l}{11 \times A}$$

$$V'' = IR''$$

And $V = V'$

$$\frac{I \times 2.5\rho}{A \times 10} = \frac{\rho \times l}{11 \times A} \times I$$

Or $\frac{2.5 \times 11}{10} = l = 2.75 \text{ m}$

75.

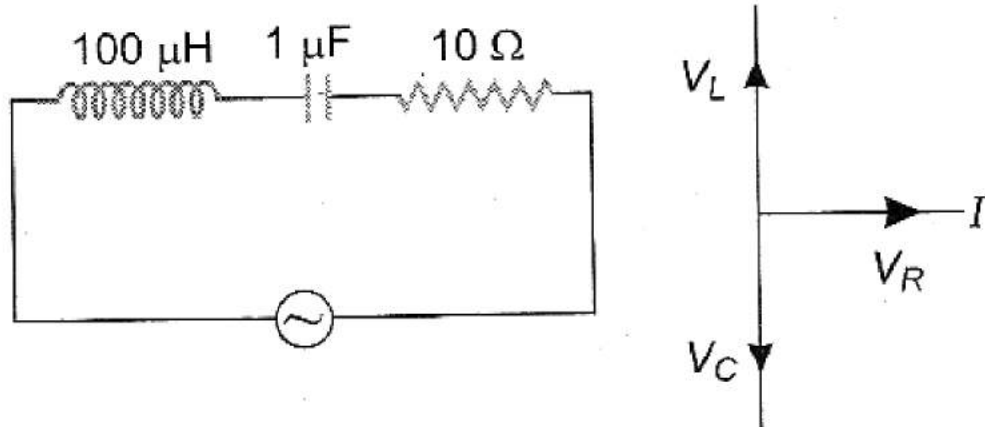

Impedance, $Z = \sqrt{X_L - X_C^2 + R^2}$

Or $Z = \sqrt{\omega L - \frac{1}{\omega C}^2 + R^2}$

Inductive reactance

$$X_L = \omega L = 70 \times 10^3 \times 100 \times 10^{-6} = 7 \Omega$$

Capacitance reactance

$$X_C = \frac{1}{\omega C} = \frac{1}{70 \times 10^3 \times 1 \times 10^{-6}}$$

$$= \frac{1}{7 \times 10^{-2}} = \frac{10^2}{7} = \frac{100}{7}$$

As $X_C > X_L$

Hence, circuit behave like as R - C circuit.

76. Magnetic field at the centre of the loop

$$B = \frac{\mu_0}{4 \pi} \cdot \frac{I \cdot 2\pi R}{R^2} \dots\dots\dots (i)$$

For the wire which is looped double let radius becomes r

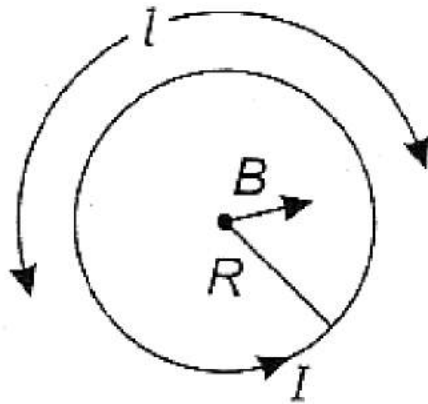

Then, $\frac{l}{2} = 2\pi r$

or $\frac{l}{4\pi} = r$

$\therefore B' = \frac{\mu_0}{4\pi} \cdot \frac{I \cdot 2\pi r \times 2}{r^2}$

Or $B' = \frac{\mu_0}{4\pi} \cdot \frac{I \cdot \frac{l}{2}}{\frac{l}{4\pi}}$

Or $B' = \frac{\mu_0}{4\pi} \cdot \frac{I \times 16\pi^2}{l^2}$ (ii)

Now, $B = \frac{\mu_0}{4\pi} \cdot \frac{I \cdot l}{\frac{l}{2\pi}}$ $R = \frac{l}{2\pi}$ (iii)

Dividing Eq (ii) by Eq. (iii) we get

$$\frac{B'}{B} = \frac{\frac{\mu_0 I \cdot 16\pi^2}{4\pi l^2}}{\frac{\mu_0 I l \cdot 4\pi^2}{4\pi l^2}}$$

Or $\frac{B'}{B} = 4$

Or $B' = 4B$

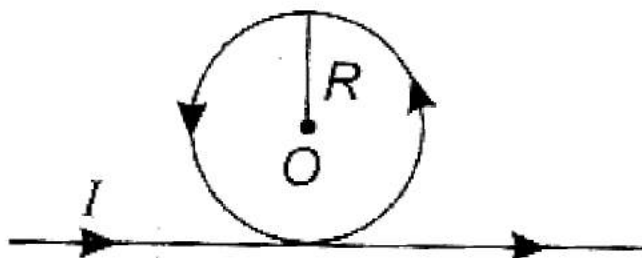

Magnetic field due to long wire at O point

$$B_1 = \frac{\mu_0}{2\pi} \frac{I}{R} \quad \text{upward direction}$$

Magnetic field due to loop at O point

$$B_2 = \frac{\mu_0}{4\pi} \cdot \frac{I \cdot 2\pi R}{R^2}$$

$$B_2 = \frac{\mu_0}{2} \cdot \frac{I}{R} \quad \text{in upward direction}$$

Hence, resultant magnetic field at centre O

$$B = B_1 + B_2$$

$$B = \frac{\mu_0 I}{2\pi R} \pi + 1 \text{ T}$$

78. Work function $W_0 = 3.31 \times 10^{-19} \text{ J}$

Wavelength of incident radiation

$$\lambda = 5000 \times 10^{-10} \text{ m}$$

$$E = W_0 + KE$$

(According to Einstein equation)

$$\frac{hc}{\lambda} = 3.31 \times 10^{-19} + KE$$

$$KE = -3.31 \times 10^{-19} + \frac{6.62 \times 10^{-34} \times 3 \times 10^8}{5000 \times 10^{-10}}$$

$$= -3.31 \times 10^{-19} + \frac{6.62 \times 3}{5} \times 10^{-19}$$

$$= (-3.31 \times 1.324 \times 3) \times 10^{-19}$$

$$= (3.972 - 3.31) \times 10^{-19} = 0.662 \times 10^{-19} \text{ J}$$

$$\Rightarrow E = \frac{0.662 \times 10^{-19}}{1.6 \times 10^{-19}} = 0.41 \text{ eV}$$

79. From Einstein's equation

$$E = W_0 + \frac{1}{2} mv^2$$

$$\frac{2E - W_0}{m} = v$$

or A charged particle placed in uniform magnetic field experience a force

$$F = \frac{mv^2}{r}$$

$$\text{or } evB = \frac{mv^2}{r}$$

$$\text{or } r = \frac{mv}{eB}$$

$$\text{or } r = \frac{m \frac{2E - W_0}{m}}{eB}$$

$$\Rightarrow r = \frac{2mE - W_0}{eB}$$

80. $N_1 = N_0 e^{-10\lambda t}$

and $N_2 = N_0 e^{-\lambda t}$

$$\Rightarrow \frac{N_1}{N_2} = \frac{1}{e} = e^{-1} = e^{-10\lambda + \lambda t}$$

$$= e^{-9\lambda t}$$

$$\Rightarrow t = \frac{1}{9\lambda}$$

81. In circuit A, both (p-n) junction diode act as forward biasing www.bearingce.com

Hence, current flows in circuit A.

Total resistance R is given by

$$\frac{1}{R} = \frac{1}{4} + \frac{1}{4}$$

Or $\frac{1}{R} = \frac{2}{4}$

Or $R = 2\Omega$

According to Ohm's law

$$V = I_A R$$

or $8 = I_A \times 2$

or $I_A = 4A$

In circuit B, lower p-n-junction diode is reverse biased. Hence, no current will flow but upper diode is forward biased so current, can flow through it

$$V = I_B R$$

or $8 = I_B \times 4$

or $I_B = 2A$

82. After impact the bullet and block move together and come to rest after covering a distance of 40 m.

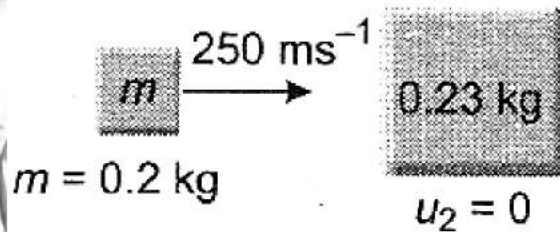

By conservation of momentum,

$$m_1 u_1 + m_2 u_2 = m_1 v_1 + m_2 v_2$$

$$\text{or } 0.02 \times 250 + 0.23 \times 0 = 0.02 v + 0.23 v$$

$$5 + 0 = v (0.25)$$

$$\frac{500}{25} v = 20 \text{ ms}^{-1}$$

Now, by conservation of energy

$$\frac{1}{2} M v^2 = \mu R \cdot d$$

$$\text{or } \frac{1}{2} \times 0.25 \times 400 = \mu \times 0.25 \times 9.8 \times 40$$

$$\Rightarrow \mu = \frac{200}{9.8 \times 40} = 0.51$$

83. Let after the time (t) the position of A is $(0, v_A t)$ and position of B = $(v_B t, 10)$. Distance between them

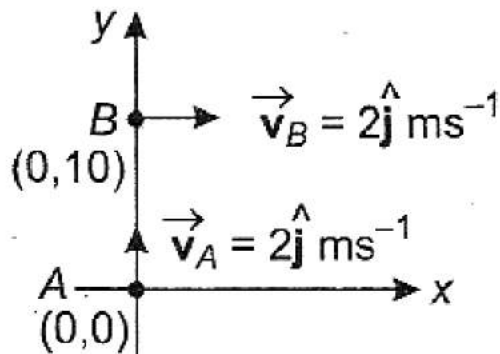

$$l = \sqrt{0 - v_B t^2 + v_A t - 10^2}$$

$$\text{or } l^2 = (2t)^2 + (2t - 10)^2$$

$$\text{or } l^2 = 1 = 4t^2 + 4t^2 + 100 - 40t$$

$$\Rightarrow l = 8t^2 + 100 - 40t$$

$$\text{Now, } \frac{dl}{dt} (16t - 40) = 0$$

$$t = \frac{40}{16} = 2.5\text{s}$$

As $\frac{d^2l}{dt^2} = -16 = (-ve)$

Hence, l will be minimum.

84. In this process potential energy of the metre stick will be converted into rotational kinetic energy.

PE of metre stick = $\frac{mgl}{2}$

Because its centre of gravity lies at the middle of the rod.

Rotational kinetic energy $E = \frac{1}{2} I\omega^2$

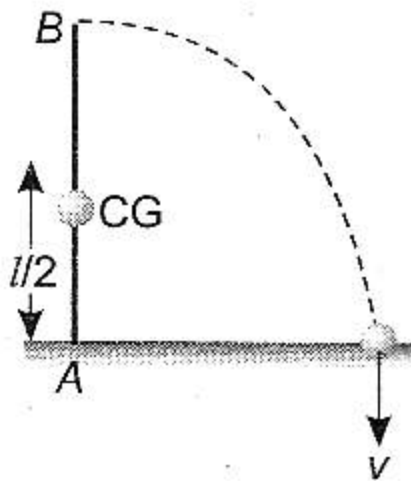

$I =$ moment of inertia of metre stick about point $A = \frac{3l^2}{3}$.

By the law of conservation of energy

$$mg \frac{l}{2} = \frac{1}{2} I\omega^2 = \frac{1}{2} \frac{ml^2}{3} \frac{v_B}{l}^2$$

By solving, we get $v_B = \sqrt{3gl}$

85. Given, $r = 0.4 \text{ m}$,

$a = 8 \text{ rad s}^{-1}$,

$$m = 4 \text{ kg}, 1 = ?$$

$$\text{Torque, } \tau = I a$$

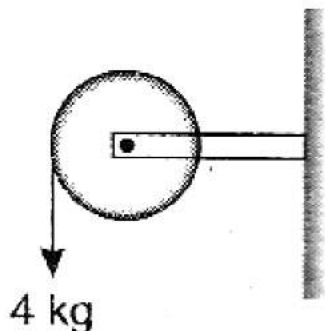

$$m g r + I \cdot a$$

$$\text{or } 4 \times 10 \times 0.4 = I \times 8$$

$$\Rightarrow I = \frac{16}{8} = 2 \text{ kg-m}^2$$

$$\text{or } I = 2 \text{ kg - m}^2$$

CHEMISTRY

86. Given: $\Delta H_f (\text{H}) = 218 \text{ kJ/mol}$



$$= \frac{436}{4.18} = 104.3 \text{ kcal/mol}$$

Thus, 104.3 kcal/mol energy is absorbed for breaking one mole of H-H bonds. Hence, H-H bond energy is 104.3 kcal/mol.

87. In Wacker process, alkene is oxidised into aldehyde.

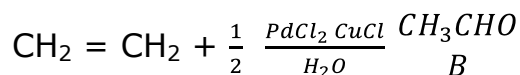

Since on ozonolysis, only alkenes produce aldehydes, 'A' must be an alkene. To decide the structure of alkene that undergoes ozonolysis, bring the products together in such a way that O atoms are face to face and, replace O by double (=) bond. Thus,

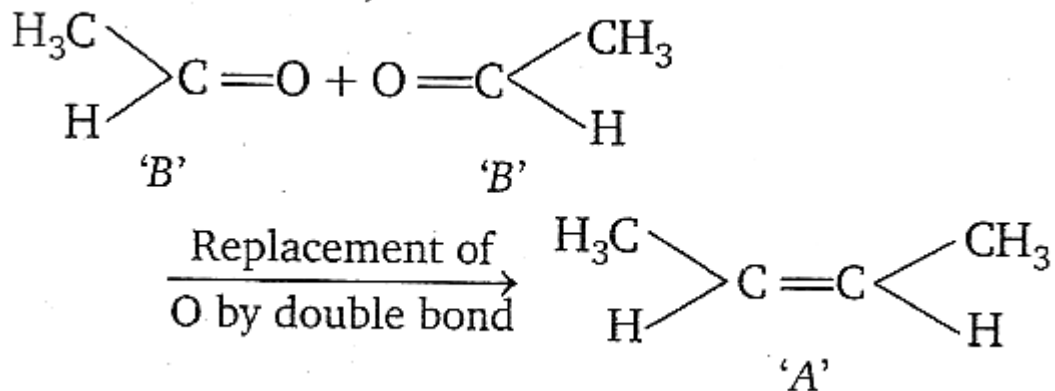

Therefore, alkyne must be

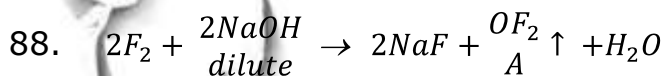
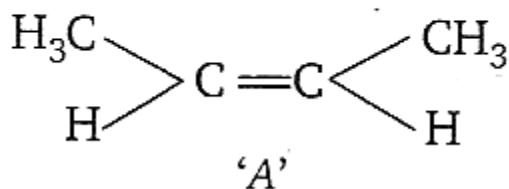
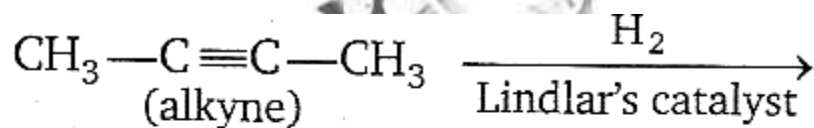

The structure of 'A' (OF₂) is as

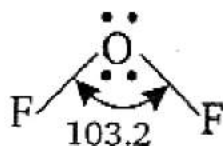

σ bonds made by O = 2

Lone pairs of electrons on O = 2

\therefore No. of orbitals used by O for hybridisation

$$= 2 + 2 = 4$$

\therefore Hybridisation of O in $\text{OF}_2 = sp^3$

Due to repulsion between two lone pairs of electrons, its shape gets distorted. Therefore, the bond angle in the molecule is 103° .

89. To decide the structure of alkene that undergoes " ozonolysis, bring the products together in such a way that O atoms are face to face, and replace O by double (=) bond. Thus,

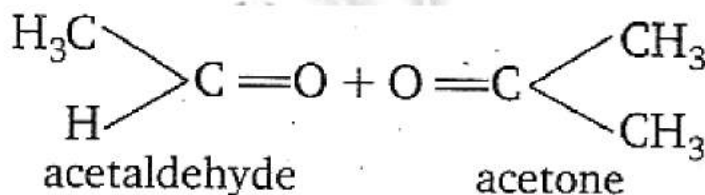

Replacement
of O by double bond \longrightarrow

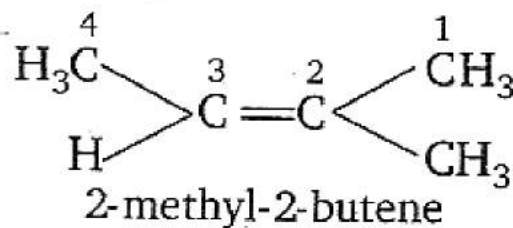

90. **Structure of XeO_3**

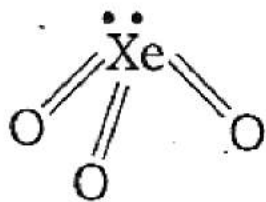

⇒ 3 pπ - dπ pi bonds.

Structure of XeO₄

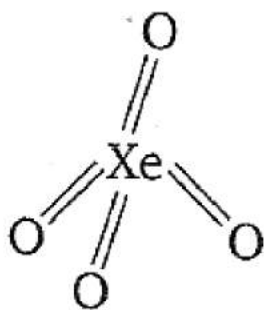

⇒ 4 pπ - dπ bonds.

91. From de-Broglie's equation

$$\lambda = \frac{h}{mv}$$

$$\Rightarrow \lambda^2 = \frac{h^2}{m^2 v^2}$$

$$\Rightarrow mv^2 = \frac{h^2}{m\lambda^2}$$

$$\therefore KE = \frac{1}{2} mv^2$$

$$\therefore KE = \frac{1}{2} \frac{h^2}{m\lambda^2}$$

$$\Rightarrow \frac{K_1}{K_2} = \frac{\lambda_2^2}{\lambda_1^2} = \frac{5}{3}$$

$$\therefore K_1 : K_2 = 25 : 9$$

92. Paramagnetic property depends upon the number of unpaired electrons. Higher the number of unpaired electrons, higher the paramagnetic property will be.

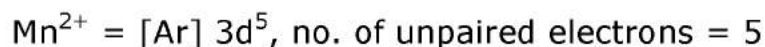
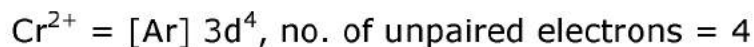
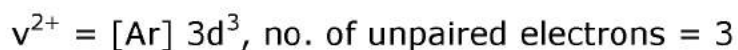
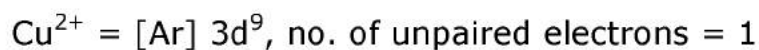

Hence, correct order is -

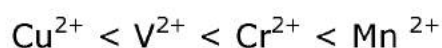

93. 1 mol = 6.023×10^{23} atoms

$$\text{KE of 1 mol} = 6.023 \times 10^4 \text{ J}$$

or KE of 6.023×10^{23} atoms

$$= 6.023 \times 10^4 \text{ J}$$

$$\therefore \text{KE of 1 atom} = \frac{6.023 \times 10^4}{6.023 \times 10^{23}}$$

$$= 1.0 \times 10^{-19} \text{ J}$$

$$h\nu_{\text{energy}} = \frac{hc}{\lambda} = \frac{6.626 \times 10^{-34} \times 3 \times 10^8}{600 \times 10^{-9}}$$

$$= 3.313 \times 10^{-19} \text{ J}$$

Minimum amount of energy required to remove an electron from the metal ion (ie, Threshold energy)

$$= h\nu - \text{KE}$$

$$= 3.313 \times 10^{-19} - 1.0 \times 10^{-19}$$

$$= 2.313 \times 10^{-19} \text{ J}$$

94. The thermosphere is the fourth layer of the earth's atmosphere www.examrace.com

and is located above the mesosphere. The air is thin in the thermosphere. The earth's thermosphere also includes the region of the atmosphere, called the ionosphere. The ionosphere is the region of the atmosphere that is filled with charged particles such as O^+ , NO^+ . The high temperature in the thermosphere can cause molecules to ionize.

95. Sulphuric anhydride is SO_3 and its structure is as follows:

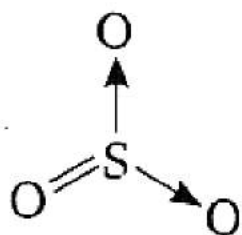

⇒ 3σ , $1 p\pi$, $2 p\pi-d\pi$ bonds are present.

96.

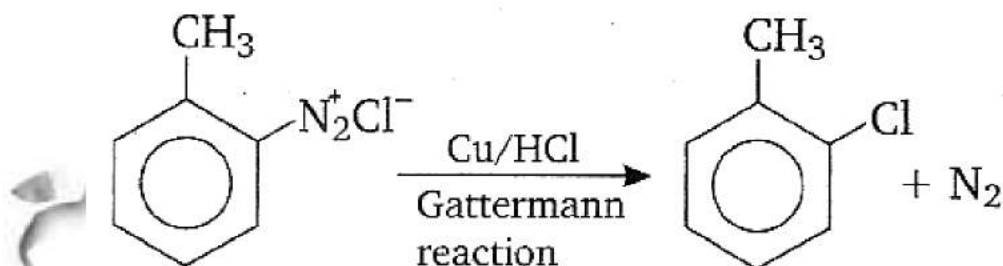

97.

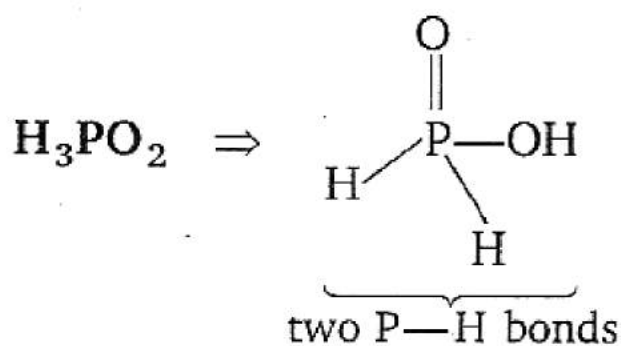
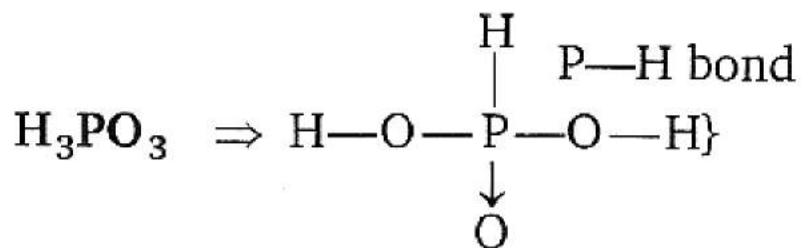

98. From the definition of dipole moment,

$$\mu = \delta \times d$$

where, δ = magnitude of electric charge

d = distance between particles (here bond length)

$$\therefore \delta = \frac{\mu}{d}$$

$$\begin{aligned} \text{or, } \frac{\delta_{\text{HCl}}}{\delta_{\text{HI}}} &= \frac{\mu_{\text{HCl}}}{\mu_{\text{HI}}} \times \frac{d_{\text{HI}}}{d_{\text{HCl}}} \\ &= \frac{1.03 \times 1.6}{1.3 \times 0.38} = 3.3:1 \end{aligned}$$

99. $\text{SiCl}_4 + 4\text{H}_2\text{O} \rightarrow \text{H}_4\text{SiO}_4 + 4\text{HCl}$

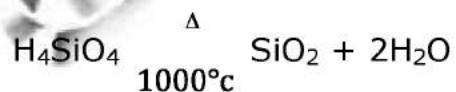

$$100. \quad \% \text{ of Cd in CdCl}_2 = \frac{0.9}{1.5} \times 100$$

$$= 60\%$$

Therefore, % of Cl₂ in CdCl₂ = 100 - 60 = 40%

$$\therefore \quad 40\% \text{ part (Cl}_2\text{) has atomic weight}$$

$$= 2 \times 35.5 = 71.0$$

$$\therefore \quad 60\% \text{ part (Cd) has atomic weight}$$

$$= \frac{71.0 \times 60}{40}$$

$$= 106.5$$

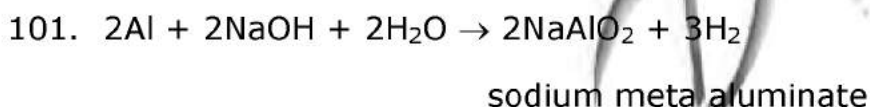

Sodiummetaaluminate, thus formed, is soluble in water and changes into the complex $[\text{Al}(\text{H}_2\text{O})_2(\text{OH})_4]^-$, in which coordination number of Al is 6.

102. Average kinetic energy per molecule

$$= \frac{3}{2} kT$$

Or $= \frac{3R}{2N_0} T$

$$= \frac{3}{2} \times \frac{8.314}{6.023 \times 10^{23}} \times 300$$

$$= 6.21 \times 10^{-21} \text{ JK}^{-1} \text{ molecule}^{-1}$$

103. Superoxides are the species having an O - O bond and O in an oxidation state of $-\frac{1}{2}$ (Superoxide ion is O₂⁻). Usually these are formed by active metals such as KO₂, RbO₂ and CsO₂. For the salts of larger anions (like O₂⁻), lattice energy increases in a

group. Since, lattice energy is the driving force for the formation of an ionic compound and its stability, the stability of the superoxides from 'K' to 'Cs' also increases.

104. Perhydrol means 30% solution of H_2O_2 .

H_2O_2 decomposes as

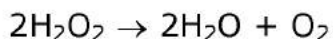

Volume strength of 30% H_2O_2 solution is 100 that means 1 mL of this solution on decomposition gives 100 mL oxygen.

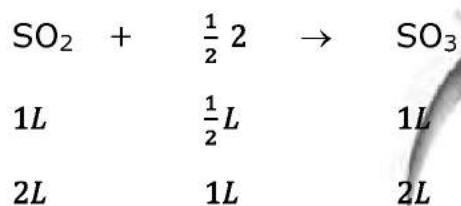

Since, 100 mL of oxygen is obtained by

$$= 1 \text{ mL of } \text{H}_2\text{O}_2$$

\therefore 1000 mL of oxygen will be obtained by

$$= \frac{1}{100} \times 1000 \text{ mL of } \text{H}_2\text{O}_2$$

$$= 10 \text{ mL of } \text{H}_2\text{O}_2$$

105. Buffer capacity, $\beta = \frac{dC_{\text{HA}}}{d_{\text{pH}}}$,

where, dC_{HA} = no. of moles of acid added per litre

d_{pH} = change in pH.

$$dC_{\text{HA}} = \frac{\text{moles of acetic acid}}{\text{volume}}$$

$$= \frac{0.12/60}{250/1000} = \frac{1}{125}$$

$$\therefore \beta = \frac{1/125}{0.02} = \frac{1}{2.5} = 0.4$$

106. (A) Felspar (orthoclase) (KAlSi_3O_8)

It is used in the manufacture of porcelain.

(B) Asbestos $\{\text{CaMg}_3(\text{SiO}_3)_4\}$

It is used for fireproof sheets, cloths etc.

(C) Pyrargyrite (Ruby silver) (Ag_3SbS_3)

It is an ore of silver.

(D) Diaspore ($\text{Al}_2\text{O}_3 \cdot \text{H}_2\text{O}$)

It is an ore of aluminium.

107. First ionisation energy increases in a period. Thus, the first IE of the elements of the second period should be as follows

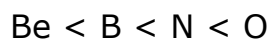

But in practice, the elements do not follow the above order. The first IE of these elements is

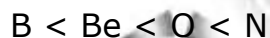

The lower IE of B than that of Be is because in B ($1s^2, 2s^2 2p^1$), electron is to be removed from 2p which is easy while in Be ($1s^2, 2s^2$), electron is to be removed from 2s which is difficult. The low IE of O than that of N is because of the half-filled 2 p orbitals in N ($1s^2, 2s^2 2p^3$).

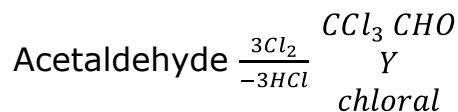

109.

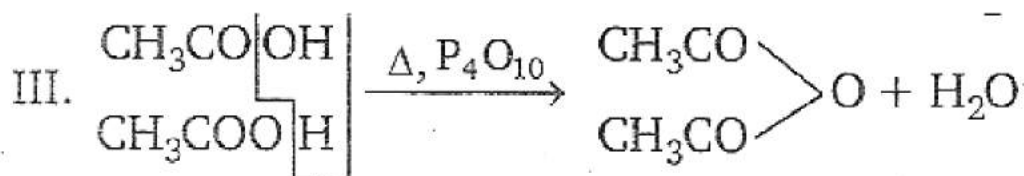
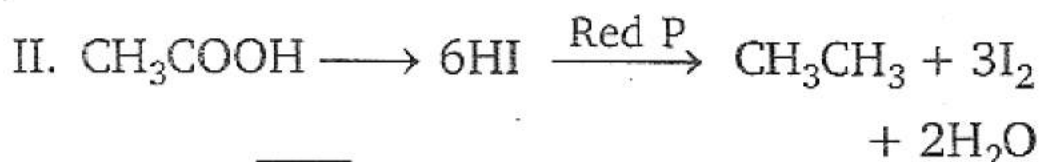
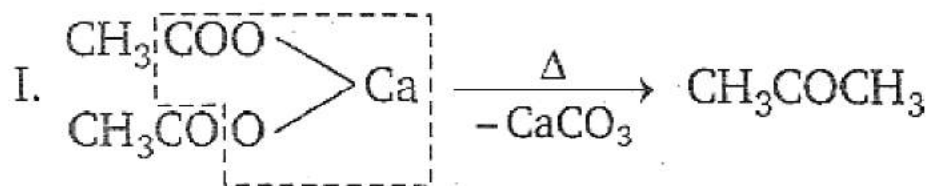

$$110. \quad C = 85.71\% = \frac{85.71}{12} = 7.14; \quad \frac{7.14}{7.14} = 1$$

$$H = 14.29\% = \frac{14.29}{1} = 14.29; \quad \frac{14.29}{7.14} = 2$$

\therefore Empirical formula = CH_2

And, empirical formula weight = $12 + 2 = 14$

Again, molecular formula weight

$$= 2 \times \text{vapour density}$$

$$= 2 \times 14 = 28$$

$$\therefore n = \frac{28}{14} = 2$$

\therefore Molecular formula = $\text{CH}_2 \cdot 2 = \text{C}_2\text{H}_4$

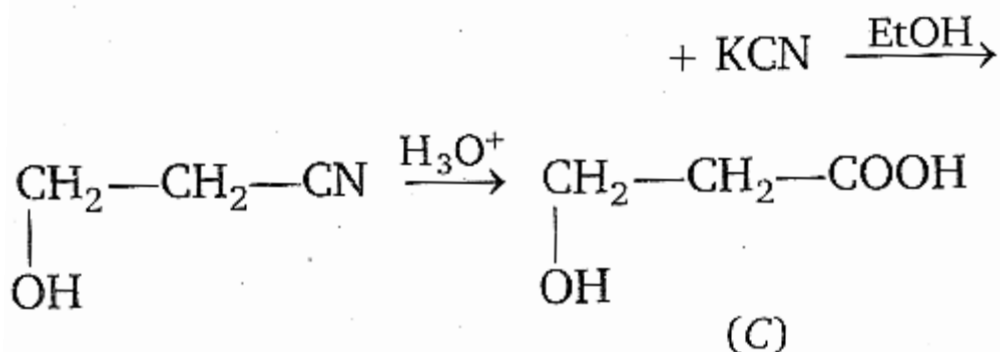
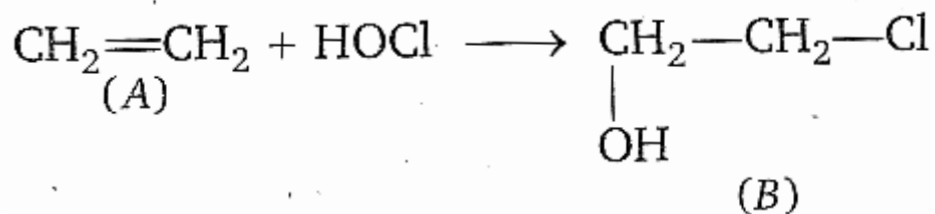

111. Tripeptides are amino acids polymers in which three individual amino acid units, called residues, are linked together by amide bonds.

In these, an amine group "from one residue forms an amide bond with the carboxyl group of a second residue, the amino group of the second forms an amide bond with the carboxyl group of the third.

Therefore, glycine ($\text{NH}_2\text{-CH}_2\text{-COOH}$),

alanine ($\text{CH}_3\text{—CH—COOH}$) and phenyl alanine



$\text{C}_6\text{H}_5\text{—CH}_2\text{—CHCOOH}$ can be linked in six

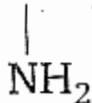

different ways.

112. A codon is a specific sequence of three adjacent bases on a strand of DNA or RNA that provides genetic code information for a particular amino acid.
113. Dopamine is produced in several areas of the brain. If the amount of dopamine increases in the brain, the patient may be affected with Parkinson's disease. The IUPAC name of dopamine is 2-(3, 4-dihydroxyphenyl) ethylamine and its structure is as follows:

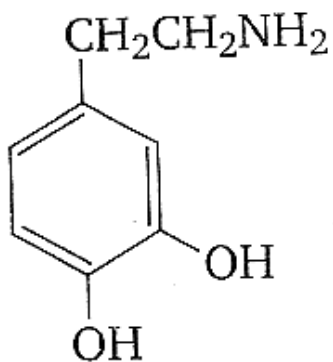

114. Freezing point of a substance is the temperature at which the solid and the liquid forms of the substance are in equilibrium."

If a non-volatile solute is added to the solvent, there is decrease

in vapour pressure of the solution and thus the freezing point of the solution is less than that of pure solvent. It is called depression in freezing point.

115.



N-linked to ethyl carbon

116. For the given cell,



The cell reactions are as follows

At anode:



At cathode:



Net cell reaction:



$$\begin{aligned} \therefore \Delta G^\circ_{\text{reaction}} &= \Sigma \Delta G^\circ_P - \Sigma \Delta G^\circ_R \\ &= 78 - 129 - (-109) \\ &= +58 \text{ kJ / mol} \end{aligned}$$

$$\Delta G^\circ = -nFE^\circ$$

$$58 \times 10^3 \text{ J} = -1 \times 96500 \times E^\circ_{\text{cell}}$$

$$E^\circ_{\text{cell}} = \frac{-58 \times 1000}{96500}$$

$$= -0.6 \text{ V}$$

117. Crotonaldehyde is produced by the aldol condensation of acetaldehyde-

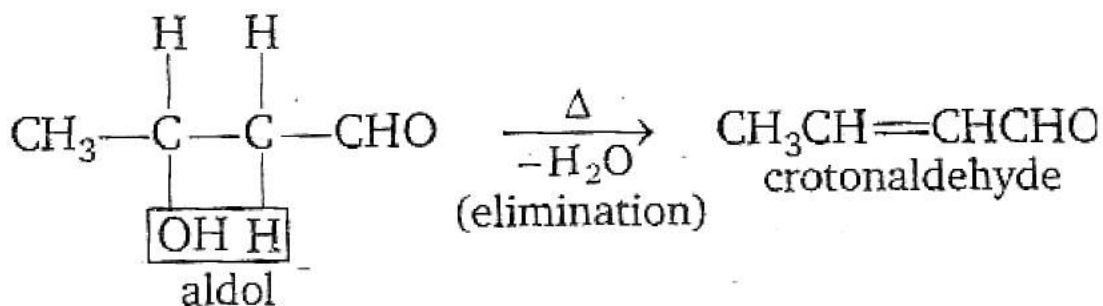
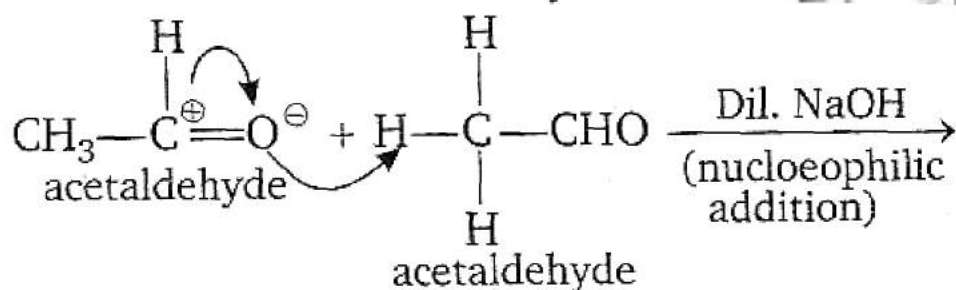

118. $\text{BaCl}_2 + 2\text{NaOH} \rightarrow \text{Ba(OH)}_2 + 2\text{NaCl}$

$$\lambda_{m \text{ Ba OH}_2}^\circ = \lambda_{m \text{ BaCl}_2}^\circ + 2\lambda_{m \text{ NaCl}}^\circ$$

$$= 280 \times 10^{-4} + 2 \times 248 \times 10^{-4}$$

$$- 2 \times 126 \times 10^{-4}$$

$$= (280 + 496 - 252) \times 10^{-4}$$

$$= 524 \times 10^{-4} \text{ Sm}^2 \text{ mol}^{-1}$$

119. Density, $d = \frac{MZ}{N_0 a^3}$

where, Z = number of atoms in unit cell

$$\begin{aligned} \therefore Z &= \frac{dN_0 a^3}{M} \\ &= \frac{8.92 \times 6.023 \times 10^{23} \times 362 \times 10^{-10}^3}{63.55} \\ &= 4.0 \end{aligned}$$

Thus, metal has face centred unit cell.

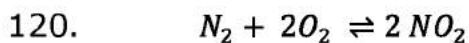

$$K_1 = \frac{NO_2^2}{N_2 O_2^2}$$

or $100 = \frac{NO_2^2}{N_2 O_2^2}$ (i)

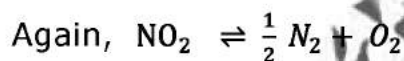

$$K_2 = \frac{N_2^{1/2} O_2}{NO_2}$$

or $K_2^2 = \frac{N_2 O_2^2}{NO_2^2}$ (ii)

eqs. (i) \times (ii), we get

$$100 \times K_2^2 = 1$$

or $K_2^2 = \frac{1}{100}$ or $K_2 = \frac{1}{10} = 0.1$

121. For a first order reaction,

$$t = \frac{2.303}{\lambda} \log_{10} \frac{a}{a-x}$$

Let initial amount of reactant is 100.

$$\frac{t_1}{t_2} = \frac{\log \frac{100}{100-75}}{\log \frac{100}{100-25}}$$

∴ λ remains constant

$$= \frac{\log \frac{100}{25}}{\log \frac{100}{75}} = \frac{\log 4}{\log 4/3}$$

$$= \frac{\log 4}{\log 4 - \log 3}$$

$$= \frac{2 \times 0.3010}{2 \times 0.3010 - 0.4771}$$

122. $a = \frac{a_{\text{observed}}}{l \times C} = \frac{-1.2}{5 \times \frac{6.15}{1000}} = -39^\circ$

123. Let the concentration of potassium acetate is x .

From Henderson's equation,

$$pH = pK_a + \log \frac{\text{salt}}{\text{acid}}$$

$$4.8 = -\log 1.8 \times 10^{-5} + \log \frac{x \times 50}{20 \times 0.1 M}$$

$$4.8 = 4.74 + \log 25x$$

or $\log 25x = 0.06$

$$25x = 1.148$$

∴ $x = 0.045 M$

124. By ' $2A + \frac{C}{2} \rightarrow B$ ', we get

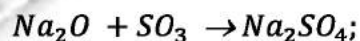

$$\Delta H = -2 \times 146 + \frac{259}{2} - 418$$

or $\Delta H = -580.5 \approx -581 \text{ kJ}$

125. As_2S_3 is a negative sol. It is obvious that cations are effective in coagulating negative sols. According to Hardy Schulze rule, greater the valency of the coagulating ion, greater is its coagulating power. Thus, out of the given, AlCl_3 (Al^{3+}) is most effective for causing coagulation of As_2S_3 sol.

REASONING

141. From problem figure (1) to (2), double figure is converted into single figure and vice-versa. Also, figures change place in a set order. Hence, answer figure (d) will replace the sign?

142. 'Nurse' receives instructions from 'Doctor' and 'Follower' receives instructions from 'Leader'.

143. $24 \times 2 + 4 = 52,$
 $52 \times 2 + 4 = 108,$
 $108 \times 2 + 4 = 220,$
 $220 \times 2 + 4 = 444,$

and so on. Hence, number 112 is wrong and should be replaced by 108.

144. Only I and III are implicit because in the relief camp the facilities of food, water and shelter are available.

145. It is clear that answer figure (b) completes the original figure, which looks like as shown in the adjacent figure. Hence,

alternative (b) is the correct answer.

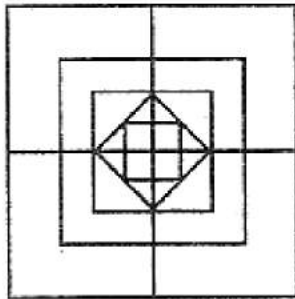

146. Clearly figure (x) is embedded in alternative figure (b). The portion which figure (x) occupies in the alternative figure has been shown in the adjacent figure. Hence, the correct answer figure is - (b),

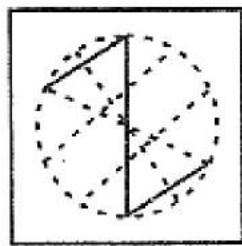

147. Symbol appearing on the faces of dice can be shown as given in the figure. We see from the figure that symbol o will appear on the opposite face symbol x.

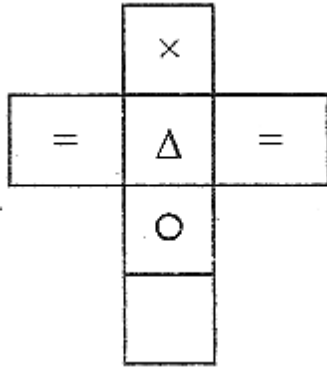

148. Figure X is the first step in which a circular piece of paper is folded from upper to the lower half along the diameter. In figure Y both the extreme ends of the figure X have been folded to form a triangle and then as given in figure Z, a cut has been marked from the right side. It is clear that this cut will result into two marks, one in the lower half and one in the upper half of the paper, when it will be unfolded. Answer figure (b) represents the correct design of the unfolded paper and hence, is the correct answer.

150. Converting alphabets into mathematical symbols as- given above, we get

$$\begin{aligned}
 &18 \times 1274 + 5 - 6 \\
 &= 18 \times \frac{12}{4} + 5 - 6 \\
 &= 18 \times 3 + 5 - 6 \\
 &= 54 + 5 - 6 \\
 &= 59 - 6 = 53
 \end{aligned}$$

Hence, option (c) is the correct answer.