

Q. No. 1 – 5 Carry One Mark Each

1. Choose the most appropriate word from the options given below to complete the following sentence.

Communication and interpersonal skills are _____ important in their own ways.

- (A) each (B) both (C) all (D) either

Answer: (B)

2. Which of the options given below best completes the following sentence?

She will feel much better if she _____.

- (A) will get some rest (B) gets some rest
(C) will be getting some rest (D) is getting some rest

Answer: (B)

3. Choose the most appropriate pair of words from the options given below to complete the following sentence.

She could not _____ the thought of _____ the election to her bitter rival.

- (A) bear, loosing (B) bare, loosing (C) bear, losing (D) bare, losing

Answer: (C)

4. A regular die has six sides with numbers 1 to 6 marked on its sides. If a very large number of throws show the following frequencies of occurrence: 1 → 0.167; 2 → 0.167; 3 → 0.152; 4 → 0.166; 5 → 0.168; 6 → 0.180. We call this die

- (A) irregular (B) biased (C) Gaussian (D) insufficient

Answer: (B)

Exp: For a very large number of throws, the frequency should be same for unbiased throw. As it not same, then the die is biased.

5. Fill in the missing number in the series.

2 3 6 15 ___ 157.5 630

Answer: 45

Exp:

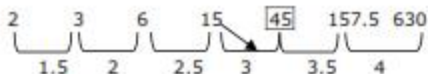

2nd number is in increasing order as shown above
1st number

Q. No. 6 – 10 Carry One Mark Each

6. Find the odd one in the following group

Q,W,Z,B B,H,K,M W,C,G,J M,S,V,X
 (A) Q,W,Z,B (B) B,H,K,M (C) W,C,G,J (D) M,S,V,X

Answer: (C)

Exp:

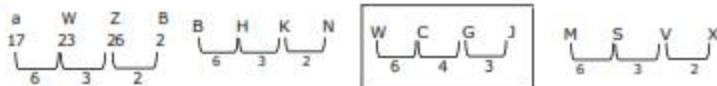

7. Lights of four colors (red, blue, green, yellow) are hung on a ladder. On every step of the ladder there are two lights. If one of the lights is red, the other light on that step will always be blue. If one of the lights on a step is green, the other light on that step will always be yellow. Which of the following statements is not necessarily correct?

- (A) The number of red lights is equal to the number of blue lights
 (B) The number of green lights is equal to the number of yellow lights
 (C) The sum of the red and green lights is equal to the sum of the yellow and blue lights
 (D) The sum of the red and blue lights is equal to the sum of the green and yellow lights

Answer: (D)

8. The sum of eight consecutive odd numbers is 656. The average of four consecutive even numbers is 87. What is the sum of the smallest odd number and second largest even number?

Answer: 163

Exp: Eight consecutive odd number = 656

$$a-6, a-4, a-2, a, a+2, a+4, a+6$$

$$a+8=656$$

$$a=81$$

$$\text{Smallest } m=75 \quad \dots (1)$$

Average consecutive even numbers

$$\Rightarrow \frac{a-2+a+a+2+a+4}{4} = 87$$

$$\Rightarrow a = 86$$

Second largest number = 88

$$1+2=163$$

9. The total exports and revenues from the exports of a country are given in the two charts shown below. The pie chart for exports shows the quantity of each item exported as a percentage of the total quantity of exports. The pie chart for the revenues shows the percentage of the total revenue generated through export of each item. The total quantity of exports of all the items is 500 thousand tonnes and the total revenues are 250 crore rupees. Which item among the following has generated the maximum revenue per kg?

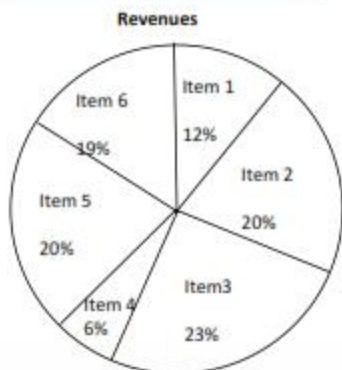
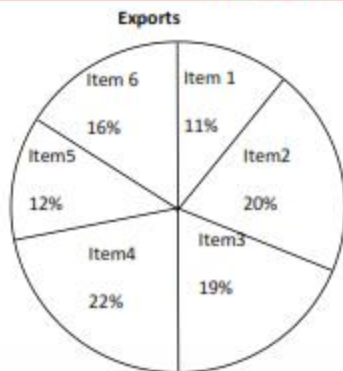

(A) Item 2

(B) Item 3

(C) Item 6

(D) Item 5

Answer: (D)

Exp:

Item:2

$$\frac{20}{100} \times 250 \times 10^7$$

$$\frac{20}{100} \times 500 \times 10^7$$

$$0.5 \times 10^4 = 5 \times 10^3 \quad \boxed{1} = \text{Item 2}$$

Item: 6

$$\frac{19}{16} = 1.18 = \text{Item 6}$$

Item:3

$$\frac{23 \times 250 \times 10^7}{19 \times 500 \times 10^7}$$

$$1.2 = \text{Item 3}$$

Item:5

$$\frac{20}{12} = \frac{5}{3} = 1.6 \Rightarrow \boxed{1.6} = \text{Item 5}$$

10. It takes 30 minutes to empty a half-full tank by draining it at a constant rate. It is decided to simultaneously pump water into the half-full tank while draining it. What is the rate at which water has to be pumped in so that it gets fully filled in 10 minutes?

(A) 4 times the draining rate
(C) 2.5 times the draining rate

(B) 3 times the draining rate
(D) 2 times the draining rate

Answer: (A)

Exp: $V_{\text{in}} = 30(s)$ drawing rate = s

Total volume = 60 S tank

$$(s^1)(10) - (s)10 = 30s$$

$$s^1(s) - s = 3s$$

$$s^1 = 4s$$

$$s^1 = 4 \text{ drawing rate}$$

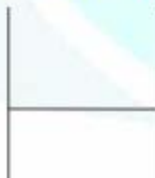

Q. No. 1 – 25 Carry One Mark Each

1. The determinant of matrix A is 5 and the determinant of matrix B is 40. The determinant of matrix AB is _____.

Answer: 200

Exp: $|AB| = |A||B| = (5).(40) = 200$

2. Let X be a random variable which is uniformly chosen from the set of positive odd numbers less than 100. The expectation $E[X]$ is _____.

Answer: 50

Exp: $X = 1, 3, 5, \dots, 99 \Rightarrow n = 50$ (number of observations)

$$\therefore E(x) = \frac{1}{n} \sum_{j=1}^n x_j = \frac{1}{50} [1 + 3 + 5 + \dots + 99] = \frac{1}{50} (50)^2 = 50$$

3. For $0 \leq t < \infty$, the maximum value of the function $f(t) = e^{-t} - 2e^{-2t}$ occurs at

- (A) $t = \log_e 4$ (B) $t = \log_e 2$ (C) $t = 0$ (D) $t = \log_e 8$

Answer: (A)

Exp: $f'(t) = -e^{-t} + 4e^{-2t} = 0$

$$\Rightarrow e^{-t} [4e^{-t} - 1] \Rightarrow e^{-t} = \frac{1}{4} \Rightarrow t = \log_e 4$$

and $f''(t) < 0$ at $t = \log_e 4$

4. The value of $\lim_{x \rightarrow \infty} \left(1 + \frac{1}{x}\right)^x$ is
- (A) $\ln 2$ (B) 1.0 (C) e (D) ∞

Answer: (C)

Exp: $\lim_{x \rightarrow \infty} \left(1 + \frac{1}{x}\right)^x = e$ (standard limit)

5. If the characteristic equation of the differential equation

$$\frac{d^2 y}{dx^2} + 2\alpha \frac{dy}{dx} + y = 0$$

has two equal roots, then the values of α are

- (A) ± 1 (B) 0, 0 (C) $\pm j$ (D) $\pm 1/2$

Answer: (A)

Exp: For equal roots, Discriminant $B^2 - 4AC = 0$

$$\Rightarrow 4\alpha^2 - 4 = 0$$

$$\Rightarrow \alpha = \pm 1$$

6. Norton's theorem states that a complex network connected to a load can be replaced with an equivalent impedance
- (A) in series with a current source (B) in parallel with a voltage source
- (C) in series with a voltage source (D) in parallel with a current source

Answer: (D)

Exp: Norton's theorem

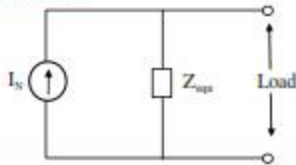

7. In the figure shown, the ideal switch has been open for a long time. If it is closed at $t=0$, then the magnitude of the current (in mA) through the $4\text{k}\Omega$ resistor at $t = 0^+$ is _____.

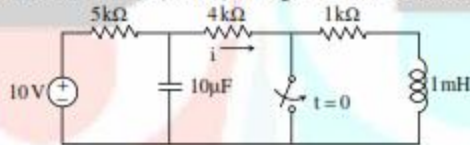

Answer: 1.2 mA

Exp: For $t = 0^+$

$$i(0^+) = \frac{10}{9\text{k}} \Rightarrow 1.11\text{mA}$$

$$i(0^+) = 1.2\text{mA}$$

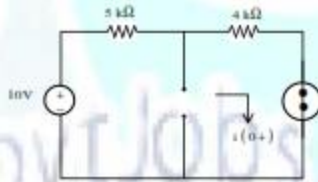

8. A silicon bar is doped with donor impurities $N_D = 2.25 \times 10^{15}$ atoms / cm^3 . Given the intrinsic carrier concentration of silicon at $T = 300$ K is $n_i = 1.5 \times 10^{10}$ cm^{-3} . Assuming complete impurity ionization, the equilibrium electron and hole concentrations are
- (A) $n_0 = 1.5 \times 10^{10}$ cm^{-3} , $p_0 = 1.5 \times 10^5$ cm^{-3}
- (B) $n_0 = 1.5 \times 10^{10}$ cm^{-3} , $p_0 = 1.5 \times 10^{15}$ cm^{-3}
- (C) $n_0 = 2.25 \times 10^{15}$ cm^{-3} , $p_0 = 1.5 \times 10^{10}$ cm^{-3}
- (D) $n_0 = 2.25 \times 10^{15}$ cm^{-3} , $p_0 = 1 \times 10^5$ cm^{-3}

Answer: (D)

Exp: $N_D = 2.25 \times 10^{15}$ Atom / cm^3

$$n_i = 1.5 \times 10^{10} / \text{cm}^3$$

Since complete ionization taken place,

$$n_0 = N_D = 2.25 \times 10^{15} / \text{cm}^3$$

$$p_0 = \frac{n_i^2}{n_0} = \frac{(1.5 \times 10^{10})^2}{2.25 \times 10^{15}} = 1 \times 10^5 / \text{cm}^3$$

9. An increase in the base recombination of a BJT will increase
- (A) the common emitter dc current gain β
 - (B) the breakdown voltage BV_{CEO}
 - (C) the unity-gain cut-off frequency f_T
 - (D) the transconductance g_m

Answer: (B)

10. In CMOS technology, shallow P-well or N-well regions can be formed using
- (A) low pressure chemical vapour deposition
 - (B) low energy sputtering
 - (C) low temperature dry oxidation
 - (D) low energy ion-implantation

Answer: (D)

11. The feedback topology in the amplifier circuit (the base bias circuit is not shown for simplicity) in the figure is

- (A) Voltage shunt feedback
- (B) Current series feedback
- (C) Current shunt feedback
- (D) Voltage series feedback

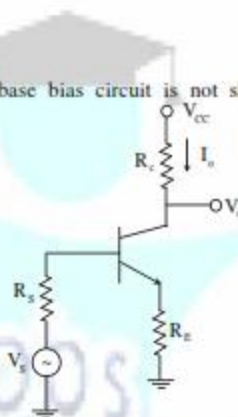

Answer: (B)

Exp: By opening the output feed back signed becomes zero. Hence it is current sampling. As the feedback signal v_f is subtracted from the signal same v_i it is series mixing.

12. In the differential amplifier shown in the figure, the magnitudes of the common-mode and differential-mode gains are A_{cm} and A_d , respectively. If the resistance R_E is increased, then
- (A) A_{cm} increases
 - (B) common-mode rejection ratio increases
 - (C) A_d increases
 - (D) common-mode rejection ratio decreases

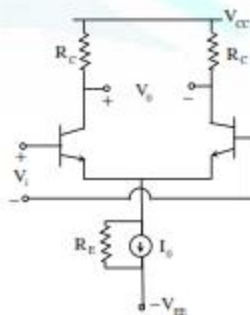

Answer: (B)

Exp: A_d does not depend on R_E

A_{cm} decreases as R_E is increased

$$\therefore \text{CMRR} = \frac{A_d}{A_{cm}} = \text{Increases}$$

13. A cascade connection of two voltage amplifiers A1 and A2 is shown in the figure. The open-loop gain A_{v0} , input resistance R_{in} , and output resistance R_o for A1 and A2 are as follows:

$$A1: A_{v0} = 10, R_{in} = 10k\Omega, R_o = 1k\Omega$$

$$A2: A_{v0} = 5, R_{in} = 5k\Omega, R_o = 200\Omega$$

The approximate overall voltage gain V_{out}/V_{in} is _____.

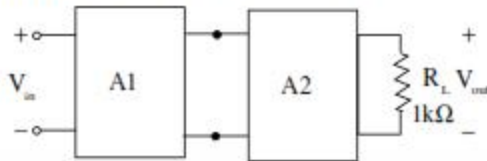

Answer: 34.722

Exp: Overall voltage gain, $A_v = \frac{V_o}{V_i} = A_{v1} A_{v2} \left[\frac{Z_{o1}}{Z_{o1} + Z_{i2}} \right] \left[\frac{R_L}{R_L + Z_{o2}} \right]$

$$= 10 \times 5 \left[\frac{5k}{5k + 1k} \right] \left[\frac{1k}{1k + 200} \right]$$

$$A_v = 34.722$$

14. For an n -variable Boolean function, the maximum number of prime implicants is
 (A) $2^{(n-1)}$ (B) $n/2$ (C) 2^n (D) $2^{(n-1)}$

Answer: (D)

Exp: For an n -variable Boolean function, the maximum number of prime implicants = $2^{(n-1)}$

15. The number of bytes required to represent the decimal number 1856357 in packed BCD (Binary Coded Decimal) form is _____.

Answer: 4

Exp: In packed BCD (Binary Coded Decimal) typically encoded two decimal digits within a single byte by taking advantage of the fact that four bits are enough to represent the range 0 to 9.

So, 1856357 is required 4-bytes to stored these BCD digits

16. In a half-subtractor circuit with X and Y as inputs, the Borrow (M) and Difference ($N = X - Y$) are given by

(A) $M = X \oplus Y, N = XY$

(B) $M = XY, N = X \oplus Y$

(C) $M = \overline{X}Y, N = X \oplus Y$

(D) $M = XY, N = \overline{X \oplus Y}$

Answer: (C)

Exp: Function Table for Half-subtractor is

| X | Y | Difference (N) | Borrow (M) |
|---|---|-------------------------------|------------|
| 0 | 0 | 0 | 0 |
| 0 | 1 | $N = X \oplus Y$ and $m = XY$ | 1 |
| 1 | 0 | 1 | 0 |
| 1 | 1 | 0 | 0 |

Hence, $N = X \oplus Y$ and $m = \bar{X}Y$

17. An FIR system is described by the system function

$$H(z) = 1 + \frac{7}{2}z^{-1} + \frac{3}{2}z^{-2}$$

The system is

- (A) maximum phase (B) minimum phase (C) mixed phase (D) zero phase

Answer: (C)

Exp: Minimum phase system has all zeros inside unit circle maximum phase system has all zeros outside unit circle mixed phase system has some zero outside unit circle and some zeros inside unit circle.

$$\text{for } H(s) = 1 + \frac{7}{2}z^{-1} + \frac{3}{2}z^{-2}$$

One zero is inside and one zero outside unit circle hence mixed phase system

18. Let $x[n] = x[-n]$. Let $X(z)$ be the z-transform of $x[n]$. If $0.5 + j0.25$ is a zero of $X(z)$, which one of the following must also be a zero of $X(z)$.

- (A) $0.5 - j0.25$ (B) $1/(0.5 + j0.25)$
 (C) $1/(0.5 - j0.25)$ (D) $2 + j4$

Answer: (B)

Exp: Given $x[n] = x[-n]$

$$\Rightarrow x(z) = x(z^{-1}) \text{ [Time reversal property in } z\text{-transform]}$$

$$\Rightarrow \text{if one zero is } 0.5 + j0.25$$

$$\text{then other zero will be } \frac{1}{0.5 + j0.25}$$

19. Consider the periodic square wave in the figure shown.

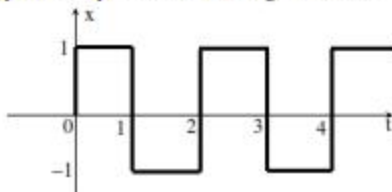

The ratio of the power in the 7th harmonic to the power in the 5th harmonic for this waveform is closest in value to _____.

Answer: 0.5

Exp: For a periodic sequence wave, nth harmonic component is $\propto \frac{1}{n}$

$$\Rightarrow \text{power in nth harmonic component is } \propto \frac{1}{n^2}$$

\Rightarrow Ratio of the power in 7th harmonic to power in 5th harmonic for given waveform is

$$\frac{\frac{1}{7^2}}{\frac{1}{5^2}} = \frac{25}{49} = 0.5$$

20. The natural frequency of an undamped second-order system is 40 rad/s. If the system is damped with a damping ratio 0.3, the damped natural frequency in rad/s is _____.

Answer: 38.15 τ /sec

Exp: Given $\omega_n = 40 \tau/\text{sec}$

$$\xi = 0.3$$

$$\omega_d = \omega_n \sqrt{1 - \xi^2}$$

$$\omega_d = 40 \sqrt{1 - (0.3)^2}$$

$$\omega_d = 38.15 \tau/\text{sec}$$

21. For the following system,

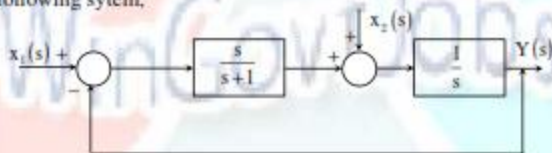

When $X_1(s) = 0$, the transfer function $\frac{y(s)}{x_2(s)}$ is

(A) $\frac{s+1}{s^2}$

(B) $\frac{1}{s+1}$

(C) $\frac{s+2}{s(s+1)}$

(D) $\frac{s+1}{s(s+2)}$

Answer: (D)

Exp: If $X_1(s) = 0$

$\frac{Y(s)}{X_2(s)}$: The block diagram becomes

$$\frac{Y(s)}{X_2(s)} = \frac{\frac{1}{s}}{1 + \frac{1}{s} \cdot \frac{s}{s+1}} = \frac{\frac{1}{s}}{(s+2)/s+1} \Rightarrow \frac{(s+1)}{s(s+2)}$$

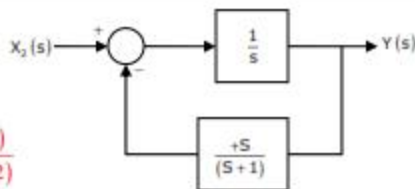

22. The capacity of a band-limited additive white Gaussian noise (AWGN) channel is given by $C = W \log_2 \left(1 + \frac{P}{\sigma^2 W} \right)$ bits per second (bps), where W is the channel bandwidth, P is the average power received and σ^2 is the one-sided power spectral density of the AWGN. For a fixed $\frac{P}{\sigma^2} = 1000$, the channel capacity (in kbps) with infinite bandwidth ($W \rightarrow \infty$) is approximately
- (A) 1.44 (B) 1.08 (C) 0.72 (D) 0.36

Answer: (A)

$$\text{Exp: } C = \lim_{W \rightarrow \infty} W \log_2 \left[1 + \frac{P}{\sigma^2 W} \right] = \lim_{W \rightarrow \infty} \frac{W \ln \left[1 + \frac{P}{\sigma^2 W} \right]}{\ln 2}$$

$$= \frac{1}{\ln 2} \lim_{W \rightarrow \infty} \frac{\ln \left[1 + \frac{P}{\sigma^2 W} \right]}{\frac{P}{\sigma^2 W}} \cdot \frac{P}{\sigma^2} = \frac{P}{\sigma^2 \ln 2} \lim_{W \rightarrow \infty} \frac{\ln \left[1 + \frac{P}{\sigma^2 W} \right]}{\frac{P}{\sigma^2 W}}$$

This limit is equivalent to

$$\lim_{x \rightarrow 0} \frac{\ln[1+x]}{x} = 1 = \frac{P}{\sigma^2 \ln 2} = \ln_2 e \frac{P}{\sigma^2} = 1.44 \text{ Kbps}$$

23. Consider sinusoidal modulation in an AM system. Assuming no overmodulation, the modulation index (μ) when the maximum and minimum values of the envelope, respectively, are 3 V and 1 V, is _____.

Answer: 0.5

$$\text{Exp: } \mu = \frac{A(t)_{\max} - A(t)_{\min}}{A(t)_{\max} + A(t)_{\min}}$$

$$\mu = \frac{3-1}{3+1} = \frac{1}{2} = 0.5$$

24. To maximize power transfer, a lossless transmission line is to be matched to a resistive load impedance via a $\lambda/4$ transformer as shown.

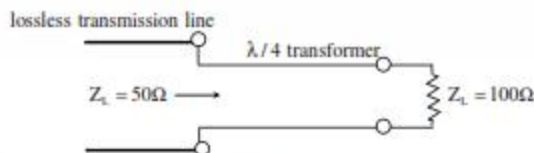

The characteristic impedance (in Ω) of the $\lambda/4$ transformer is _____.

Answer: 70.7 Ω

Exp: Here impedance is matched by using QWT ($\frac{\lambda}{4}$)

$$\begin{aligned} \therefore Z_0 &= \sqrt{Z_1 Z_2} \\ &= \sqrt{100 \times 50} = 50\sqrt{2} \\ &= Z_0 = 70.7\Omega \end{aligned}$$

25. Which one of the following field patterns represents a TEM wave travelling in the positive x direction?

(A) $E = +8\hat{y}$, $H = -4\hat{z}$

(B) $E = -2\hat{y}$, $H = -3\hat{z}$

(C) $E = 2\hat{z}$, $H = +2\hat{y}$

(D) $E = -3\hat{y}$, $H = +4\hat{z}$

Answer: (B)

Exp: For TEM wave

Electric field (E), Magnetic field (H) and Direction of propagation (P) are orthogonal to each other.

Here $P = +a_x$

By verification

$E = -2a_y$, $H = -3a_z$

$E \times H = -a_x \times -a_z = +a_x \rightarrow P$

Q. No. 26 – 55 Carry Two Marks Each

26. The system of linear equations

$$\begin{pmatrix} 2 & 1 & 3 \\ 3 & 0 & 1 \\ 1 & 2 & 5 \end{pmatrix} \begin{pmatrix} a \\ b \\ c \end{pmatrix} = \begin{pmatrix} 5 \\ -4 \\ 14 \end{pmatrix} \text{ has}$$

(A) a unique solution

(B) infinitely many solutions

(C) no solution

(D) exactly two solutions

Answer: (B)

Exp: $[A/B] = \begin{bmatrix} 2 & 1 & 3 & 5 \\ 3 & 0 & 1 & -4 \\ 1 & 2 & 5 & 14 \end{bmatrix}$

$$\begin{matrix} R_2 \rightarrow 2R_2 - 3R_1 \\ R_3 \rightarrow 2R_3 - R_1 \end{matrix} \begin{bmatrix} 2 & 1 & 3 & 5 \\ 0 & -3 & -7 & -23 \\ 0 & 3 & 7 & 23 \end{bmatrix} \xrightarrow{R_2 + R_3} \begin{bmatrix} 2 & 1 & 3 & 5 \\ 0 & -3 & -7 & -23 \\ 0 & 0 & 0 & 0 \end{bmatrix}$$

Since, $\text{rank}(A) = \text{rank}(A/B) < \text{number of unknowns}$

\therefore Equations have infinitely many solutions.

27. The real part of an analytic function $f(z)$ where $z = x + jy$ is given by $e^{-x} \cos(x)$. The imaginary part of $f(z)$ is

(A) $e^{-x} \cos(x)$ (B) $e^{-x} \sin(x)$ (C) $-e^{-x} \sin(x)$ (D) $-e^{-x} \sin(x)$

Answer: (B)

Exp: real part $u = e^{-x} \cos x$ and $V = ?$

$$\begin{aligned} dv &= \frac{\partial v}{\partial x} dx + \frac{\partial v}{\partial y} dy \\ &= -\frac{\partial u}{\partial y} dx + \frac{\partial u}{\partial x} dy \quad (U \text{ sin g } C - R \text{ equations}) = e^{-x} \cos x dx - e^{-x} \sin x dy = d[e^{-x} \sin x] \end{aligned}$$

Integrating, we get $V = e^{-x} \sin x$

28. The maximum value of the determinant among all 2×2 real symmetric matrices with trace 14 is _____.

Answer: 49

Exp: General 2×2 real symmetric matrix is $\begin{bmatrix} y & x \\ x & z \end{bmatrix}$

$$\Rightarrow \det = yz - x^2 \text{ and trace is } y + z = 14 \text{ (given)}$$

$$\Rightarrow z = 14 - y \text{(*)}$$

$$\text{Let } f = yz - x^2 \text{ (det)} = -x^2 - y^2 + 14y \text{ (using *)}$$

Using maxima and minima of a function of two variables, we have f is maximum at $x = 0$, $y = 7$ and therefore, maximum value of the determinant is 49

29. If $r = x\hat{a}_1 + y\hat{a}_2 + z\hat{a}_3$ and $|\vec{r}| = r$, then $\text{div}(r^2 \nabla(\ln r)) = \underline{\hspace{2cm}}$.

Answer: 3

Exp: $\nabla(\ln r) = \frac{\vec{r}}{r^2} \Rightarrow \text{div}(r^2 \nabla(\ln r)) = \text{div}(\vec{r}) = 3$

$$\left[\nabla(\ln r) = \sum \hat{a}_i \frac{\partial}{\partial x_i} (\ln r) = \sum \hat{a}_i \left(\frac{1}{r} \right) \left(\frac{x_i}{r} \right) = \frac{1}{r^2} \sum \hat{a}_i x_i = \frac{\vec{r}}{r^2} \right]$$

30. A series LCR circuit is operated at a frequency different from its resonant frequency. The operating frequency is such that the current leads the supply voltage. The magnitude of current is half the value at resonance. If the values of L, C and R are 1 H, 1 F and 1Ω , respectively, the operating angular frequency (in rad/s) is _____.

Answer: 0.45 t/sec

Exp: The operating frequency (ω_0), at which current leads the supply,

$$\text{i.e., } \omega_0 < \omega,$$

again magnitude of current is half the value at resonance

$$\text{i.e., at } \omega = \omega_s \Rightarrow I_x = \frac{V}{|Z|}$$

$$\text{at } \omega = \omega_s \Rightarrow I_{\text{resonance}} = \frac{V}{R}$$

$$I_x = \frac{I_{\text{resonance}}}{2}$$

$$\text{i.e., } \frac{V}{|Z|} = \frac{V}{2R} = |Z| = 2R$$

Given $R = 1\Omega$; $L = 1H$; $C = 1F$

$$|Z| = \sqrt{R^2 + \left(\frac{1}{\omega_c} - \omega L\right)^2} = 2$$

$$= R^2 + \left(\frac{1}{\omega_c} - \omega L\right)^2 = 4$$

By substituting R, L & C values,

$$\Rightarrow 1 + \left(\frac{1}{\omega} - \omega\right)^2 = 4 \Rightarrow \omega^2 = \frac{1}{\omega^2} = 5$$

Assume $\omega^2 = x$, then, $x + \frac{1}{x} = 5$

$$\Rightarrow x^2 - 5x + 1 = 0$$

$$x_{1,2} = 4.791, 0.208$$

$$\text{if } x = 4.791 \Rightarrow \omega = 2.18 \text{ r/sec}$$

$$\text{if } x = 0.208 \Rightarrow \omega = 0.45 \text{ r/sec}$$

But $\omega_s < \omega$.

So, operating frequency $\omega_s = 0.45 \text{ r/sec}$

31. In the h-parameter model of the 2-port network given in the figure shown, the value of h_{22} (in S) is _____.

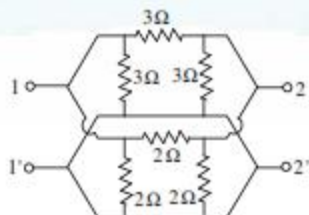

Answer: 1.24

Exp: If two, π -n/ws are connected in parallel,

The y-parameter are added

i.e., $y_{eq} = y_1 + y_2$

$$y_1 = \begin{bmatrix} \frac{2}{3} & -\frac{1}{3} \\ -\frac{1}{3} & \frac{2}{3} \end{bmatrix} \quad y_2 = \begin{bmatrix} 1 & -\frac{1}{2} \\ -\frac{1}{2} & 1 \end{bmatrix}$$

$$y_{eq} = \begin{bmatrix} \frac{5}{3} & -\frac{5}{6} \\ -\frac{5}{6} & \frac{5}{3} \end{bmatrix}$$

$$h = \begin{bmatrix} \frac{1}{y_{11}} & -\frac{y_{12}}{y_{11}} \\ \frac{y_{21}}{y_{11}} & \frac{\Delta y}{y_{11}} \end{bmatrix}$$

where $\Delta y = y_{11}y_{22} - y_{12} - y_{21}$

The value of $h_{22} = \Delta y = \left[\left(\frac{5}{3} \right) \left(\frac{5}{3} \right) \right] - \left[\left(-\frac{5}{6} \right) \left(-\frac{5}{6} \right) \right]$

$$\Delta y = 2.0833$$

$$y_{11} = \frac{5}{3} \quad \therefore h_{22} = 1.24$$

32. In the figure shown, the capacitor is initially uncharged. Which one of the following expressions describes the current $I(t)$ (in mA) for $t > 0$?

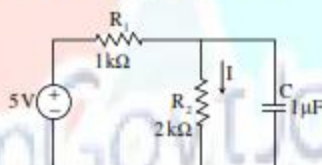

(A) $I(t) = \frac{5}{3}(1 - e^{-t/\tau})$, $\tau = \frac{2}{3}$ msec

(B) $I(t) = \frac{5}{2}(1 - e^{-t/\tau})$, $\tau = \frac{2}{3}$ msec

(C) $I(t) = \frac{5}{2}(1 - e^{-t/\tau})$, $\tau = 3$ msec

(D) $I(t) = \frac{5}{2}(1 - e^{-t/\tau})$, $\tau = 3$ msec

Answer: (A)

Exp: $V_c(t) = V_{R2}(t) = V_{final} + [V_{initial} - V_{final}] e^{-t/\tau}$

$$\tau = R_{eq} \cdot C_{eq} \Rightarrow \frac{2}{3} \times 10^3 \times 10^{-6}$$

$$R_{eq} = 2K \parallel 1K \Rightarrow \frac{2}{3} K\Omega$$

$$C_{eq} = 1\mu F$$

$$\tau = \frac{2}{3} \text{ msec}$$

$$V_{\text{total}} = 0 \text{ volts}$$

$$V_{\text{total}} = V_{s_1} = 5 \cdot \frac{2}{3} = \frac{10}{3} \text{ volts}$$

$$V_{R_2}(t) = \frac{10}{3} - \frac{10}{3} e^{-t/\tau}$$

$$V_{R_2}(t) = \frac{10}{3} [1 - e^{-t/\tau}] \text{ volts} \Rightarrow i_{R_2}(t) = \frac{V_{R_2}(t)}{2K} = \frac{5}{3} [1 - e^{-t/\tau}] \text{ mA}$$

33. In the magnetically coupled circuit shown in the figure, 56% of the total flux emanating from one coil links the other coil. The value of the mutual inductance (in H) is _____.

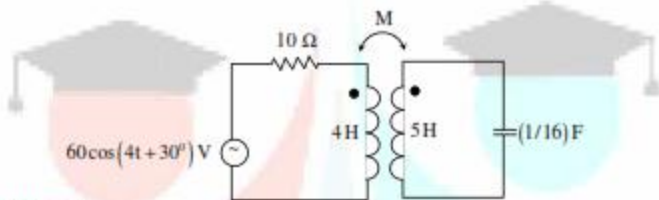

Answer: 2.49 Henry

Exp: Given 56% of the total flux emanating from one coil links to other coil.
i.e. $K = 56\% \Rightarrow 0.56$

$$\text{We have, } K = \frac{M}{\sqrt{L_1 L_2}}$$

$$L_1 = 4H; L_2 = 5H$$

$$M = (0.56) \sqrt{20} \Rightarrow M = 2.50H$$

34. Assume electronic charge $q = 1.6 \times 10^{-19}$ C, $kT/q = 25$ mV and electron mobility $\mu_n = 1000$ $\text{cm}^2/\text{V}\cdot\text{s}$. If the concentration gradient of electrons injected into a P-type silicon sample is $1 \times 10^{21}/\text{cm}^4$, the magnitude of electron diffusion current density (in A/cm^2) is _____.

Answer: 4000

Exp: Given $q = 1.6 \times 10^{-19}$; $\frac{kT}{q} = 25 \text{ mV}$, $\mu_n = 1000 \text{ cm}^2 / \text{v}\cdot\text{s}$

$$\text{From Einstein relation, } \frac{D_n}{\mu_n} = \frac{kT}{q}$$

$$\Rightarrow D_n = 25 \text{ mV} \times 1000 \text{ cm}^2 / \text{v}\cdot\text{s}$$

$$\Rightarrow 25 \text{ cm}^2 / \text{s}$$

$$\text{Diffusion current Density } J = q D_n \frac{dn}{dx}$$

$$= 1.6 \times 10^{-19} \times 25 \times 1 \times 10^{21}$$

$$= 4000 \text{ A} / \text{cm}^2$$

35. Consider an abrupt PN junction (at $T = 300\text{ K}$) shown in the figure. The depletion region width x_n on the N-side of the junction is $0.2\ \mu\text{m}$ and the permittivity of silicon (ϵ_s) is $1.044 \times 10^{-12}\text{ F/cm}$. At the junction, the approximate value of the peak electric field (in kV/cm) is _____.

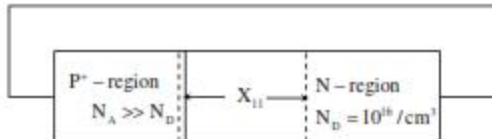

Answer: 30.66

Exp: Given $x_n = 0.2\ \mu\text{m}$, $\epsilon_s = 1.044 \times 10^{-12}\text{ F}/\mu\text{m}$

$$N_D = 10^{16} / \text{cm}^3$$

$$\text{Peak Electric field, } E = \frac{q N_D x_n}{\epsilon}$$

$$= \frac{1.6 \times 10^{-19} \times 10^{16} \times 0.00002}{1.044 \times 10^{-12}} = 30.66\text{ KV/cm}$$

36. When a silicon diode having a doping concentration of $N_A = 9 \times 10^{16}\text{ cm}^{-3}$ on p-side and $N_D = 1 \times 10^{16}\text{ cm}^{-3}$ on n-side is reverse biased, the total depletion width is found to be $3\ \mu\text{m}$. Given that the permittivity of silicon is $1.04 \times 10^{-12}\text{ F/cm}$, the depletion width on the p-side and the maximum electric field in the depletion region, respectively, are
- (A) $2.7\ \mu\text{m}$ and $2.3 \times 10^5\text{ V/cm}$ (B) $0.3\ \mu\text{m}$ and $4.15 \times 10^5\text{ V/cm}$
 (C) $0.3\ \mu\text{m}$ and $0.42 \times 10^5\text{ V/cm}$ (D) $2.1\ \mu\text{m}$ and $0.42 \times 10^5\text{ V/cm}$

Answer: (B)

Exp: Given $N_A = 9 \times 10^{16} / \text{cm}^3$; $N_D = 1 \times 10^{16} / \text{cm}^3$

$$\text{Total depletion width } x = x_n + x_p = 3\ \mu\text{m}$$

$$\epsilon = 1.04 \times 10^{-12}\text{ F/cm}$$

$$\frac{x_n}{x_p} = \frac{N_A}{N_D} = \frac{9 \times 10^{16}}{1 \times 10^{16}}$$

$$x_n = 9x_p \dots\dots\dots(1)$$

$$\text{Total Depletion width, } x_n + x_p = 3\ \mu\text{m}$$

$$9x_p + x_p = 3\ \mu\text{m}$$

$$x_p = 0.3\ \mu\text{m}$$

$$\text{Max. Electric field, } E = \frac{q N_A x_p}{\epsilon} = \frac{1.6 \times 10^{-19} \times 9 \times 10^{16} \times 0.3\ \mu\text{m}}{1.04 \times 10^{-12}} = 4.15 \times 10^5\text{ V/cm}$$

37. The diode in the circuit shown has $V_{on} = 0.7$ Volts but is ideal otherwise.
 If $V_i = 5\sin(\omega t)$ Volts, the minimum and maximum values of V_o (in Volts) are, respectively,

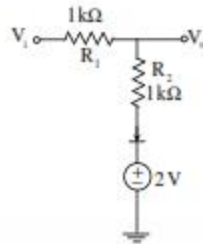

- (A) -5 and 2.7 (B) 2.7 and 5 (C) -5 and 3.85 (D) 1.3 and 5

Answer: (C)

Exp: When V_i makes Diode 'D' OFF, $V_o = V_i$

$$\therefore V_o(\min) = -5V$$

When V_i makes diode 'D' ON,

$$V_o = \frac{(V_i - 0.7 - 2)}{R_1 + R_2} + V_{on} + 2V$$

$$\begin{aligned} \therefore V_o(\max) &= \frac{(5 - 0.7 - 2)1k}{1k + 1k} + 0.7 + 2V \\ &= 3.85V \end{aligned}$$

38. For the n-channel MOS transistor shown in the figure, the threshold voltage V_{th} is 0.8 V. Neglect channel length modulation effects. When the drain voltage $V_D = 1.6$ V, the drain current I_D was found to be 0.5 mA. If V_D is adjusted to be 2 V by changing the values of R and V_{DD} , the new value of I_D (in mA) is

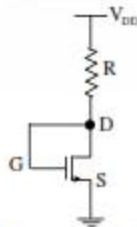

- (A) 0.625 (B) 0.75 (C) 1.125 (D) 1.5

Answer: (C)

Exp: Given $V_{th} = 0.8V$

$$\text{When } V_D = 1.6V, I_D = 0.5mA = \frac{1}{2} \mu_n \cos \frac{W}{L} (V_{DS} - V_{th})^2$$

[∵ Device is in sat]

$$\Rightarrow \frac{1}{2} \mu_n \cos \frac{W}{L} = 0.78125 \times 10^{-3} A / V^2$$

When $V_D = 2V$

$$I_D = \frac{1}{2} \mu_n \cos \frac{W}{L} (V_{DS} - V_{th})^2$$

$$= 0.78125 \times 10^{-3} (2 - 0.8) = 1.125 mA$$

39. For the MOSFETs shown in the figure, the threshold voltage $|V_t| = 2V$ and

$$K = \frac{1}{2} \mu C_{ox} \left(\frac{W}{L} \right) = 0.1 mA/V^2. \text{ The value of } I_D \text{ (in mA) is } \underline{\hspace{2cm}}.$$

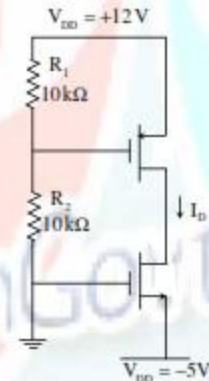

Answer: 0.9

Exp: Given $|V_t| = 2V, K = \frac{1}{2} \mu \cos \frac{W}{L} = 0.1 A / V^2$

$$I_{D1} = I_{D2} = \frac{1}{2} \mu_n \cos \frac{W}{L} (V_{GS} - V_t)^2$$

$$= 0.1 mA / V^2 (5 - 2)^2$$

$$= 0.9 mA$$

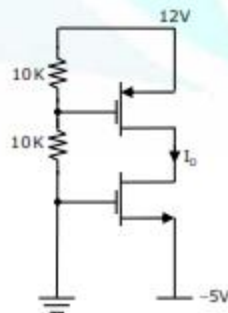

This is a synchronous circuit, so both the flip flops will trigger at the same time and will respond on falling edge of the Clock. So, the correct output (Y) waveform is associated to w_3 waveform.

41. The outputs of the two flip-flops Q1, Q2 in the figure shown are initialized to 0,0. The sequence generated at Q1 upon application of clock signal is

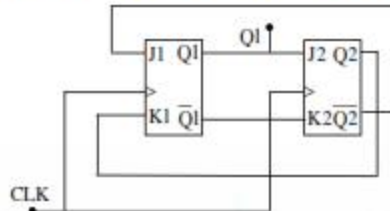

- (A) 01110... (B) 01010... (C) 00110... (D) 01100...

Answer: (D)
Exp:

| Clock | $J_1(\bar{Q}_2)$ | $K_1(Q_2)$ | $J_2(Q_1)$ | $K_2(\bar{Q}_1)$ | Q_1 | Q_2 |
|----------------------|------------------|------------|------------|------------------|-------|-------|
| Initial → | - | - | - | - | 0 | 0 |
| 1 st CP → | 1 | 0 | 0 | 1 | 1 | 0 |
| 2 nd CP → | 1 | 0 | 1 | 0 | 1 | 1 |
| 3 rd CP → | 0 | 1 | 1 | 0 | 0 | 1 |
| 4 th CP → | 0 | 1 | 0 | 1 | 0 | 0 |

So, the output sequence generated at Q_1 is 01100....

42. For the 8085 microprocessor, the interfacing circuit to input 8-bit digital data ($DI_0 - DI_7$) from an external device is shown in the figure. The instruction for correct data transfer is

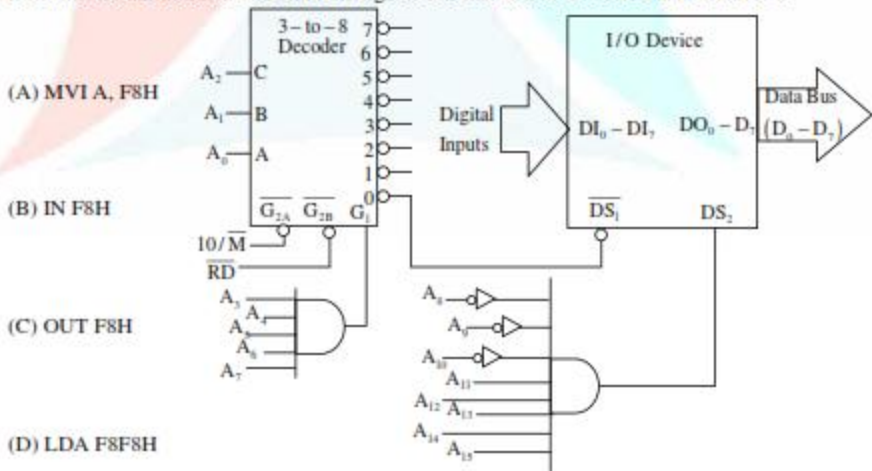

- (A) MVI A, F8H
(B) IN F8H
(C) OUT F8H
(D) LDA F8F8H

Answer: (D)

Exp: This circuit diagram indicating that it is memory mapped I/O because to enable the 3-to-8 decoder $\overline{G_{2A}}$ is required active low signal through $(\overline{I_o}/\overline{m})$ and $\overline{G_{2B}}$ is required active low through $(\overline{R_D})$ it means I/O device read the status of device LDA instruction is appropriate with device address.

Again to enable the decoder o/p of AND gate must be 1 and Ds_2 signal required is 1 which is the o/p of multi-i/p AND gate to enable I/O device.

So,

| | | | | | | | | | | | | | | | |
|----------|----------|----------|----------|----------|----------|-------|-------|-------|-------|-------|-------|-------|-------|-------|-------|
| A_{15} | A_{14} | A_{13} | A_{12} | A_{11} | A_{10} | A_9 | A_8 | A_7 | A_6 | A_5 | A_4 | A_3 | A_2 | A_1 | A_0 |
| 1 | 1 | 1 | 1 | 1 | 0 | 0 | 0 | 1 | 1 | 1 | 1 | 1 | 0 | 0 | 0 |
| F | | | | S | | | | F | | | | S | | | |

Device address = F8F8H

The correct instruction used → LDA F8F8H

43. Consider a discrete-time signal

$$x[n] = \begin{cases} n & \text{for } 0 \leq n \leq 10 \\ 0 & \text{otherwise} \end{cases}$$

If $y[n]$ is the convolution of $x[n]$ with itself, the value of $y[4]$ is _____.

Answer: 10

Exp: Given $x[n] = \begin{cases} n & \text{for } 0 \leq n \leq 10 \\ 0 & \text{elsewhere} \end{cases}$

$$y[n] = x[n] * x[n]$$

$$y[n] = \sum_{k=0}^n x[k] \cdot x[n-k]$$

$$\Rightarrow y[4] = \sum_{k=0}^4 x[k] \cdot x[4-k]$$

$$= x(0) \cdot x(4) + x(1) \cdot x(3) + x(2) \cdot x(2) + x(3) \cdot x(1) + x(4) \cdot x(0)$$

$$= 0 + 3 + 4 + 3 + 0 = 10$$

44. The input-output relationship of a causal stable LTI system is given as

$$y[n] = \alpha y[n-1] + \beta x[n]$$

If the impulse response $h[n]$ of this system satisfies the condition $\sum_{n=0}^{\infty} h[n] = 2$, the relationship between α and β is

- (A) $\alpha = 1 - \beta/2$ (B) $\alpha = 1 + \beta/2$ (C) $\alpha = 2\beta$ (D) $\alpha = -2\beta$

Answer: (A)

Exp: Given system equation as

$$y[n] = \alpha y[n-1] + \beta x[n]$$

$$\Rightarrow \frac{y(z)}{x(z)} = \frac{\beta}{1 - \alpha z^{-1}}$$

$$\Rightarrow H(z) = \frac{\beta}{1 - \alpha z^{-1}}$$

$$h[n] = \beta(\alpha)^n u[n] \quad [\text{causal system}]$$

Also given that $\sum_{n=0}^{\infty} h[n] = 2$

$$\beta \left[\frac{1}{1 - \alpha} \right] = 2$$

$$1 - \alpha = \frac{\beta}{2}$$

$$\alpha = 1 - \frac{\beta}{2}$$

45. The value of the integral $\int_{-\infty}^{\infty} \sin^2(5t) dt$ is _____.

Answer: 0.2

Exp: We can use parsevalis theorem

$$\text{Let } x(t) \sin(5t) = \frac{\sin 5\pi t}{5\pi}$$

\Rightarrow in frequency domain

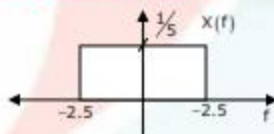

$$\text{Now, } \int_{-\infty}^{\infty} x^2(t) dt = \int_{-\infty}^{\infty} x^2(f) df = \int_{-1/5}^{1/5} \left(\frac{1}{5} \right)^2$$

$$= \frac{1}{25} \times 5 = \frac{1}{5} = 0.2$$

46. An unforced linear time invariant (LTI) system is represented by

$$\begin{bmatrix} \dot{x}_1 \\ \dot{x}_2 \end{bmatrix} = \begin{bmatrix} -1 & 0 \\ 0 & -2 \end{bmatrix} \begin{bmatrix} x_1 \\ x_2 \end{bmatrix}$$

If the initial conditions are $x_1(0) = 1$ and $x_2(0) = -1$, the solution of the state equation is

- (A) $x_1(t) = -1, x_2(t) = 2$ (B) $x_1(t) = -e^{-t}, x_2(t) = 2e^{-t}$
 (C) $x_1(t) = e^{-t}, x_2(t) = -e^{-2t}$ (D) $x_1(t) = -e^{-t}, x_2(t) = -2e^{-t}$

Answer: (C)

Exp: Solution of state equation of $X(t) = L^{-1}[SI - A^{-1}]X(0)$

$$X(0) = \begin{bmatrix} 1 \\ -1 \end{bmatrix}, A = \begin{bmatrix} -1 & 0 \\ 0 & -2 \end{bmatrix}$$

$$[SI - A]^{-1} = \begin{bmatrix} S+1 & 0 \\ 0 & S+2 \end{bmatrix}^{-1}$$

$$= \frac{1}{(S+1)(S+2)} \begin{bmatrix} S+2 & 0 \\ 0 & S+1 \end{bmatrix}$$

$$[SI - A]^{-1} = \begin{bmatrix} \frac{1}{S+1} & 0 \\ 0 & \frac{1}{S+2} \end{bmatrix}$$

$$L^{-1}[(SI - A)^{-1}] = \begin{bmatrix} L^{-1}\left[\frac{1}{S+1}\right] & 0 \\ 0 & L^{-1}\left[\frac{1}{S+2}\right] \end{bmatrix}$$

$$L^{-1}[(SI - A)^{-1}] = \begin{bmatrix} e^{-t} & 0 \\ 0 & e^{-2t} \end{bmatrix}$$

$$\begin{bmatrix} X_1(t) \\ X_2(t) \end{bmatrix} = \begin{bmatrix} e^{-t} & 0 \\ 0 & e^{-2t} \end{bmatrix} \begin{bmatrix} 1 \\ -1 \end{bmatrix}$$

$$\begin{bmatrix} X_1(t) \\ X_2(t) \end{bmatrix} = \begin{bmatrix} -e^t \\ -e^{-2t} \end{bmatrix} \quad \therefore \begin{bmatrix} X_1(t) = e^{-t} \\ X_2(t) = -e^{-2t} \end{bmatrix}$$

47. The Bode asymptotic magnitude plot of a minimum phase system is shown in the figure.

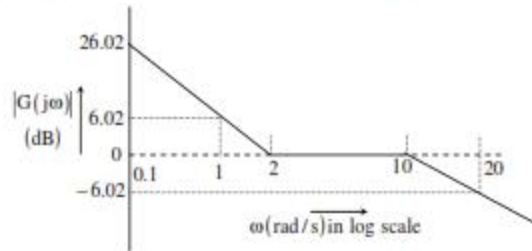

If the system is connected in a unity negative feedback configuration, the steady state error of the closed loop system, to a unit ramp input, is _____.

Answer: 0.50

Exp:

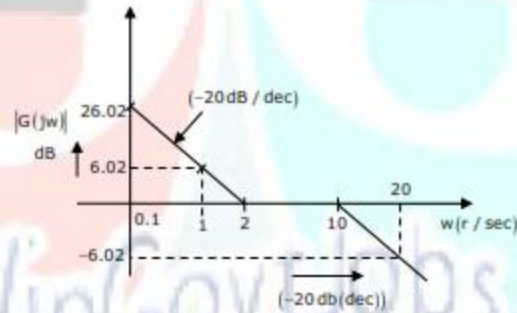

→ Due to initial slope, it is a type-1 system, and it has non zero velocity error coefficient (K_v)

→ The magnitude plot is giving 0dB at 2r/sec.

Which gives k_v

$$\therefore k_v = 2$$

$$\text{The steady state error } e_{ss} = \frac{A}{k_v}$$

given unit ramp input; $A = 1$

$$e_{ss} = \frac{1}{2}$$

$$e_{ss} = 0.50$$

48. Consider the state space system expressed by the signal flow diagram shown in the figure.

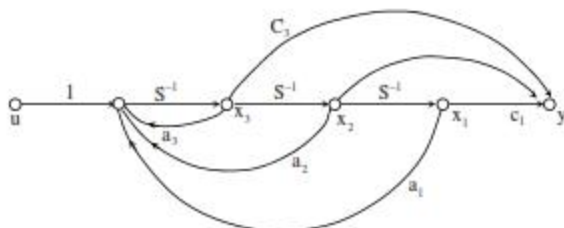

The corresponding system is

(A) always controllable

(B) always observable

(C) always stable

(D) always unstable

Answer: (A)

Exp: From the given signal flow graph, the state model is

$$\begin{bmatrix} \dot{X}_1 \\ \dot{X}_2 \\ \dot{X}_3 \end{bmatrix} = \begin{bmatrix} 0 & 1 & 0 \\ 0 & 0 & 1 \\ a_1 & a_2 & a_3 \end{bmatrix} \begin{bmatrix} X_1 \\ X_2 \\ X_3 \end{bmatrix} + \begin{bmatrix} 0 \\ 0 \\ 1 \end{bmatrix} u$$

$$Y = [C_1 \ C_2 \ C_3] \begin{bmatrix} X_1 \\ X_2 \\ X_3 \end{bmatrix}$$

$$A = \begin{bmatrix} 0 & 1 & 0 \\ 0 & 0 & 1 \\ a_1 & a_2 & a_3 \end{bmatrix}; B = \begin{bmatrix} 0 \\ 0 \\ 1 \end{bmatrix}; C = [C_1 \ C_2 \ C_3]$$

Controllability:

$$Q_c = [B \quad AB \quad A^2B]$$

$$Q_c = \begin{bmatrix} 0 & 0 & 1 \\ 0 & 1 & a_1 \\ 1 & a_1 & a_2 + a_1^2 \end{bmatrix}$$

$$|Q_c| = 1 \neq 0$$

Observability

$$Q_o = \begin{bmatrix} C \\ CA \\ CA^2 \end{bmatrix} \Rightarrow \begin{bmatrix} C_1 & C_2 & C_3 \\ a_3 C_1 & C_1 + a_2 C_2 & C_2 + a_1 C_3 \\ C_2 a_1 + C_3(a_1 a_2) & a_2 C_2 + C_3(a_1 a_2 + a_1) & C_3 + a_1 C_2 + C_1(a_1^2 + a_2) \end{bmatrix}$$

$$|Q_o| \Rightarrow \text{depends on } a_1, a_2, a_3 \text{ \& } C_1 \text{ \& } C_2 \text{ \& } C_3$$

It is always controllable

49. The input to a 1-bit quantizer is a random variable X with pdf $f_x(x) = 2e^{-2x}$ for $x \geq 0$ and $f_x(x) = 0$ for $x < 0$. For outputs to be of equal probability, the quantizer threshold should be _____.

Answer: 0.35

Exp:

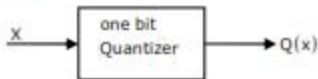

One bit quantizer will give two levels.

Both levels have probability of $\frac{1}{2}$

Pd of input X is

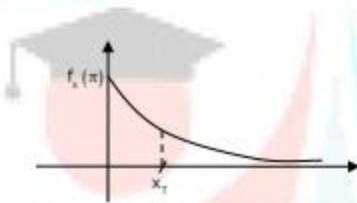

Let x_T be the threshold

$$Q(x) = \begin{cases} x_1 & x \geq x_T \\ x_2 & x < x_T \end{cases}$$

Where x_1 and x_2 are two levels

$$P\{Q(r) = x_1\} = \frac{1}{2}$$

$$\Rightarrow \int_{x_T}^{\infty} 2e^{-2x} dx = \frac{1}{2}$$

$$2 \cdot \frac{e^{-2x}}{-2} \Big|_{x_T}^{\infty} = \frac{1}{2}$$

$$-e^{-2\infty} + e^{-2x_T} = \frac{1}{2}$$

$$e^{-2x_T} = \frac{1}{2}$$

$$-2x_T = \ln \frac{1}{2}$$

$$-2x_T = -0.693$$

$$x_T = 0.35$$

50. Coherent orthogonal binary FSK modulation is used to transmit two equiprobable symbol waveforms $s_1(t) = \alpha \cos 2\pi f_1 t$ and $s_2(t) = \alpha \cos 2\pi f_2 t$, where $\alpha = 4\text{mV}$. Assume an AWGN channel with two-sided noise power spectral density $\frac{N_0}{2} = 0.5 \times 10^{-12} \text{ W/Hz}$. Using an optimal receiver and the relation $Q(v) = \frac{1}{\sqrt{2\pi}} \int_v^{\infty} e^{-u^2/2} du$ the bit error probability for a data rate of 500 kbps is
- (A) $Q(2)$ (B) $Q(2\sqrt{2})$ (C) $Q(4)$ (D) $Q(4\sqrt{2})$

Answer: (C)

Exp: For Binary FSK

$$\text{Bit error probability} = Q\left(\sqrt{\frac{E}{N_0}}\right)$$

$E \rightarrow$ Energy per bit [No. of symbols = No. of bits]

$$E = \frac{A^2 T}{2}, A = 4 \times 10^{-3}, T = \frac{1}{500 \times 10^3} \text{ [inverse of data rate]}$$

$$\Rightarrow E = \frac{16 \times 10^{-6} \times 2 \times 10^{-4}}{2} = 16 \times 10^{-12}$$

$$N_0 = 1 \times 10^{-12}$$

$$\Rightarrow P_e = Q\left(\sqrt{\frac{16 \times 10^{-12}}{1 \times 10^{-12}}}\right) = Q(4)$$

51. The power spectral density of a real stationary random process $X(t)$ is given by

$$S_x(f) = \begin{cases} \frac{1}{w} & |f| \leq w \\ 0 & |f| > w \end{cases}$$

The value of the expectation $E\left[\pi X\left(t\right) X\left(t - \frac{1}{4w}\right)\right]$ is _____.

Answer: 4

Exp: Given $S_x(f) = \begin{cases} \frac{1}{w} & |f| \leq w \\ 0 & |f| > w \end{cases}$

$$R_x(\tau) = \int_{-w}^w \frac{1}{w} e^{j2\pi f \tau} df$$

$$= \frac{1}{w} \frac{e^{j2\pi w \tau} - e^{-j2\pi w \tau}}{j2\pi} = \frac{1}{w} \left(\frac{\sin(2\pi w \tau)}{\pi} \right)$$

$$\text{Now, } E\left[\pi X\left(t\right) X\left(t - \frac{1}{4w}\right)\right] = \pi R_x\left(\frac{1}{4w}\right) \Rightarrow \pi \cdot \frac{1}{w} \cdot \frac{\sin\left(2\pi w \cdot \frac{1}{4w}\right)}{\pi} = \frac{4}{1}$$

52. In the figure, $M(f)$ is the Fourier transform of the message signal $m(t)$ where $A = 100$ Hz and $B = 40$ Hz. Given $v(t) = \cos(2\pi f_c t)$ and $w(t) = \cos(2\pi(f_c + A)t)$, where $f_c > A$. The cutoff frequencies of both the filters are f_c .

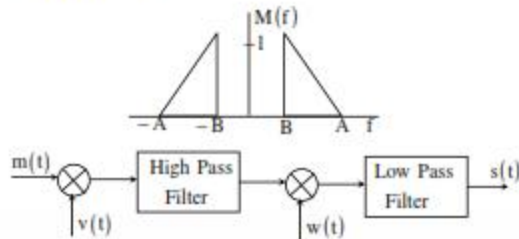

The bandwidth of the signal at the output of the modulator (in Hz) is _____.

Answer: 60

Exp: $m(t) \leftrightarrow M(f)$

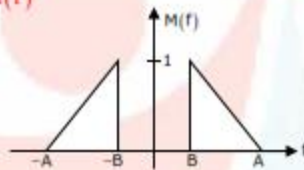

After multiplication with $V(t) = \cos(2\pi f_c t)$

Let $w'(t) = m(t) \cdot V(t)$

$\Rightarrow W'(f)$ (spectrum of $w'(t)$) is

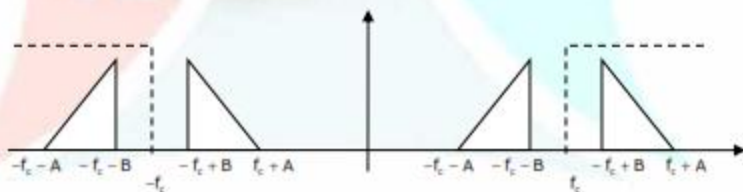

After high pass filter

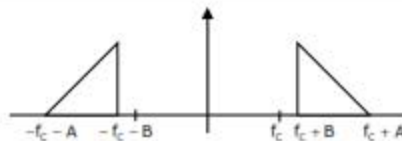

After multiplication with $\cos(2\pi(f_c + A)t)$ and low pass filter of cut off f_c

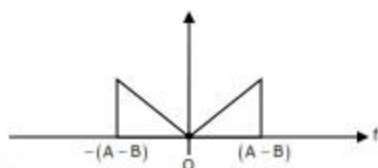

$$\begin{aligned} \text{Bandwidth} &= A - B \\ &= 100 - 40 = 60 \end{aligned}$$

53. If the electric field of a plane wave is

$$\vec{E}(Z, t) = \hat{x}3\cos(\omega t - kz + 30^\circ) - \hat{y}4\sin(\omega t - kz + 45^\circ) \text{ (mV/m)}$$

the polarization state of the plane wave is

- (A) left elliptical (B) left circular
(C) right elliptical (D) right circular

Answer: (A)

Exp: $E(z, t) = 3\cos(\omega t - kz + 30^\circ)\hat{a}_x - 4\sin(\omega t - kz + 45^\circ)\hat{a}_y$

$$E_x = 3\cos(\omega t - kz + 30^\circ)$$

$$E_y = -4\cos(\omega t - kz + 45^\circ)$$

$$\text{At } z = 0 \quad E_x = 3\cos(\omega t + 30^\circ)$$

$$E_y = -4\sin(\omega t + 45^\circ)$$

$|E_x| \neq |E_y| \rightarrow$ so Elliptical polarization

$$Q = 30^\circ - 135^\circ = -105^\circ$$

\therefore left hand elliptical (LEP)

54. In the transmission line shown, the impedance Z_{in} (in ohms) between node A and the ground is _____.

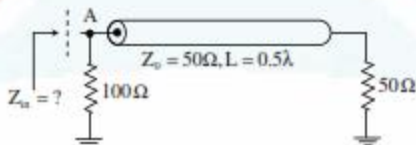

Answer: 33.33Ω

Exp: Here $l = \frac{\lambda}{2}$

$$Z_{in}(l = \lambda/2) = Z_L = 50\Omega$$

$$\therefore Z_{in} = (100 \parallel 50) = \frac{100}{3} = 33.33\Omega$$

55. For a rectangular waveguide of internal dimensions $a \times b$ ($a > b$), the cut-off frequency for the TE_{11} mode is the arithmetic mean of the cut-off frequencies for TE_{10} mode and TE_{20} mode. If $a = \sqrt{5}$ cm, the value of b (in cm) is _____.

Answer: 2

$$\text{Exp: } t_{c10} = \frac{c}{2} \sqrt{\left(\frac{1}{a}\right)^2}$$

$$t_{c10} = K \left(\frac{1}{a}\right); \quad t_{c20} = K \left(\frac{2}{a}\right)$$

$$t_{c11} = K \sqrt{\frac{1}{a^2} + \frac{1}{b^2}}$$

$$\text{Given } t_{c11} = \frac{f_{c10} + f_{c20}}{2}$$

$$K \sqrt{\frac{1}{a^2} + \frac{1}{b^2}} = \frac{K}{2} \left[\frac{1}{a} + \frac{2}{a} \right]$$

$$\sqrt{\frac{1}{a^2} + \frac{1}{b^2}} = \frac{3}{2a}$$

$$\frac{1}{5} + \frac{1}{b^2} = \frac{9}{4(5)} \Rightarrow -\frac{1}{5} + \frac{9}{20} = \frac{1}{b^2}$$

$$-0.2 + 0.45 = \frac{1}{b^2}$$

$$\therefore \frac{1}{b^2} = \frac{1}{2^2} \Rightarrow b = 2 \text{ cm}$$

WinGovtJobs