



J A G R A N
Josh

Simplifying Test Prep

WWW.JAGRANJOSH.COM

**SSC JUNIOR ENGINEERING EXAM
2013 QUESTION PAPER: PAPER I**

SA

DO NOT OPEN THE SEAL OF THE BOOKLET UNTIL YOU ARE TOLD TO DO SO

1029998

BH 2013
PAPER I
प्रश्न-पत्र I

Test Form No.
टेस्ट फॉर्म सं.
777 TG 8

Time Allowed : 2 Hours

निर्धारित समय : 2 घंटे

Maximum Marks : 200

अधिकतम अंक : 200

Read the following instructions carefully before you begin to answer the questions. This Booklet contains questions in English as well as in Hindi.
प्रश्नों के उत्तर देने से पहले नीचे लिखे अनुदेशों को ध्यान से पढ़ लें। इस पुस्तिका में प्रश्न अंग्रेजी तथा हिन्दी दोनों में दिये गये हैं।

INSTRUCTIONS TO CANDIDATES	उम्मीदवारों के लिए अनुदेश
<p>1. This Booklet contains 200 questions in all comprising the following three tests:</p> <p>Test (i) : General Intelligence and Reasoning (50 Questions)</p> <p>Test (ii) : General Awareness (50 Questions)</p> <p>Test (iii) : Part - A : General Engineering (100 Questions) (Civil and Structural)</p> <p>OR</p> <p>Part - B : General Engineering (100 Questions) (Electrical)</p> <p>OR</p> <p>Part - C : General Engineering (100 Questions) (Mechanical)</p>	<p>1. इस पुस्तिका में कुल 200 प्रश्न हैं, जिनमें निम्नलिखित तीन परीक्षण शामिल हैं:</p> <p>परीक्षण (i) : सामान्य बुद्धि और तर्क (50 प्रश्न)</p> <p>परीक्षण (ii) : सामान्य जानकारी (50 प्रश्न)</p> <p>परीक्षण (iii) : भाग - क : सामान्य इंजीनियरी (100 प्रश्न) (सिविल एवं संरचनात्मक)</p> <p>अथवा</p> <p>भाग - ख : सामान्य इंजीनियरी (100 प्रश्न) (विद्युत)</p> <p>अथवा</p> <p>भाग - ग : सामान्य इंजीनियरी (100 प्रश्न) (यांत्रिक)</p>
<p>2. In questions set bilingually in English and Hindi, in case of discrepancy, the English version will prevail.</p>	<p>2. अंग्रेजी और हिन्दी भाषा में तैयार किए गए द्विभाषी प्रश्नों में कोई विद्वेषता होने की स्थिति में अंग्रेजी विवरण मान्य होगा।</p>
<p>3. Test-I General Intelligence and Reasoning and Test-II General Awareness are compulsory for all the candidates. Candidates are required to attempt only one Section in Test-III General Engineering i.e. Part A Civil and Structural OR Part B Electrical OR Part C Mechanical as per option in the application form given by the candidates failing which you will be awarded 'ZERO' mark.</p>	<p>3. परीक्षण-I सामान्य बुद्धि और तर्क एवं परीक्षण-II सामान्य जानकारी सभी उम्मीदवारों के लिए अनिवार्य हैं। उम्मीदवारों को आवेदन-पत्र में दिए विकल्प के अनुसार परीक्षण-III सामान्य इंजीनियरी का केवल एक ही भाग-क सिविल एवं संरचनात्मक अथवा भाग-ख विद्युत अथवा भाग-ग यांत्रिक को हल करना होगा अन्यथा आपका 'शून्य' अंक दिया जाएगा।</p>
<p>4. All questions are compulsory and carry equal marks.</p>	<p>4. सभी प्रश्न अनिवार्य हैं तथा सबके बराबर अंक हैं।</p>
<p>5. The paper carries negative marking. 0.25 marks will be deducted for each wrong answer.</p>	<p>5. प्रश्न पत्र में नकारात्मक अंकन होगा। हर गलत उत्तर के लिए 0.25 अंक कटाय जाएंगे।</p>
<p>6. Before you start to answer the questions you must check up this Booklet and ensure that it contains all the pages (1-80) and see that no page is missing or repeated. If you find any defect in this Booklet, you must get it replaced immediately.</p>	<p>6. प्रश्नों के उत्तर देने से पहले आप इस पुस्तिका की जाँच करके देख लें कि इसमें पूरे पृष्ठ (1-80) हैं तथा कोई पृष्ठ कम या बुरा हो नहीं आया है। यदि आप इस पुस्तिका में कोई त्रुटि पाएँ, तो तत्काल इसके बदले दूसरी पुस्तिका ले लें।</p>
<p>7. You will be supplied the Answer-Sheet separately by the Invigilator. Before you actually start answering the questions, you must complete and code the details of Name, Roll Number, Ticket Number, Name of the examination as mentioned in the admission certificate, Date of birth, Test Form Number and Stream i.e. Civil and Structural OR Electrical OR Mechanical etc., on Side-I of the Answer-Sheet carefully. You must also put your signatures and left hand thumb impression on the Answer-Sheet at the prescribed place before you start answering the questions. These instructions must be fully complied with, failing which, your Answer-Sheet will not be evaluated and you will be awarded 'ZERO' mark.</p>	<p>7. निरीक्षक द्वारा आपको उत्तर-पत्रिका अलग से दी जाएगी। प्रश्नों के उत्तर वास्तव में शुरू करने से पहले आप उत्तर-पत्रिका के Side-I में विभागावली के अनुसार अपना नाम, रोल नम्बर, टिकट नम्बर, परीक्षा का नाम जैसे प्रवेश पत्र में लिखा गया है, अन्य तिथि, टेस्ट फॉर्म संख्या तथा विषय अर्थात् सिविल एवं संरचनात्मक या विद्युत या यांत्रिक आदि भविष्य लिखें। प्रश्नों के उत्तर देने से पहले उत्तर-पत्रिका पर निर्धारित स्थान में आप अपने हस्ताक्षर एवं बाई हाथ के उंगुठे का निशान भी अक्षर लगाएँ। उपर्युक्त अनुदेशों का पूरी तरह अनुपालन किया जाय, अन्यथा आपकी उत्तर-पत्रिका को जाँचा नहीं जाएगा और 'शून्य' अंक दिया जाएगा।</p>
<p>8. Answers must be shown by completely blackening the corresponding ovals on Side-II of the Answer-Sheet against the relevant question number by Black/Blue Ball-point Pen only. Answers which are not shown by Black/Blue Ball-point Pen will not be awarded any mark.</p>	<p>8. उत्तर-पत्रिका में सभी उत्तर Side-II में प्रश्न संख्या के सामने दिये गये सम्बन्धित अक्षरकार चक्रों को केवल काला/नीला बॉल-पॉइंट पेन से पूरी तरह काला करने दिये जाएँ। जो अक्षरकार खाने काला/नीला बॉल-पॉइंट पेन से नहीं भरे जाएँ, उनके लिए कोई अंक नहीं दिया जाएगा।</p>
<p>9. A machine will read the coded information in the OMR Answer-Sheet. In case the information is incomplete or different from the information given in the application form, such candidate will be awarded 'ZERO' mark.</p>	<p>9. ओ.एम.आर. उत्तर-पत्रिका में भरी गई कूट सूचना को एक मशीन पढ़ेगी। यदि सूचना अपूर्ण है अथवा आवेदन प्रपत्र में दी गई सूचना से भिन्न है, तो ऐसे उम्मीदवारों को 'शून्य' अंक दिया जाएगा।</p>
<p>10. The Answer-Sheet must be handed over to the Invigilator before you leave the Examination Hall.</p>	<p>10. परीक्षा-भवन छोड़ने से पहले परीक्षार्थी को उत्तर-पत्रिका निरीक्षक के हवाले कर देनी चाहिए।</p>
<p>11. Failure to comply with any of the above instructions will render a candidate liable to such action/punalty as may be deemed fit.</p>	<p>11. ऊपर के अनुदेशों में से किसी एक का भी पालन न करने पर उम्मीदवार पर नियोजकानुसार कार्यवाही की जा सकती है या कुछ दिया जा सकता है।</p>
<p>12. The manner in which the different questions are to be answered has been explained at the back of this Booklet (Page No. 80), which you should read carefully before actually answering the questions.</p>	<p>12. विभिन्न प्रश्नों के उत्तर देने की विधि इस पुस्तिका के पीछे (पृष्ठ संख्या 80) में छोटे हुए निदेशों में दी गई है, इसे आप प्रश्नों के उत्तर देने से पहले ध्यानपूर्वक पढ़ लें।</p>
<p>13. Answer the questions as quickly and as carefully as you can. Some questions may be difficult and others easy. Do not spend too much time on any question.</p>	<p>13. प्रश्नों के उत्तर जितनी जल्दी हो सके तथा ध्यानपूर्वक दें। कुछ प्रश्न आसान तथा कुछ कठिन हैं। किसी एक प्रश्न पर बहुत अधिक समय न लगाएँ।</p>
<p>14. No rough work is to be done on the Answer-Sheet. Space for rough work has been provided below the questions.</p>	<p>14. कोई रफ़ कार्य उत्तर-पत्रिका पर नहीं करना है। रफ़ कार्य के लिए स्थान प्रश्नों के नीचे दिया गया है।</p>
<p>15. "Mobile phones and wireless communication devices are completely banned in the examination halls/rooms. Candidates are advised not to keep mobile phones/any other wireless communication devices with them even switching it off, in their own interest. Failing to comply with this provision will be considered as using unfair means in the examination and action will be taken against them including cancellation of their candidature."</p>	<p>15. "मोबाइल फ़ोन/किसी भी प्रकार के तारहीन संचार साधन पूरी तरह निषिद्ध हैं। उम्मीदवारों को उनके अपने हित में सलाह दी जाती है कि मोबाइल फ़ोन/किसी अन्य तारहीन संचार साधन को स्विच ऑफ़ करके भी अपने पास न रखें। इस प्रावधान का अनुपालन न करने को परीक्षा में अनुचित उपायों का प्रयोग माना जाएगा और उनके विरुद्ध कार्यवाही की जाएगी, उनकी अभ्यर्थिता रद्द कर देने सहित।"</p>

SEAL

TEST (i) : GENERAL INTELLIGENCE AND REASONING

Directions : In questions no. 1 to 9, select the related figure/letters/number from the given alternatives.

1. Question figures :

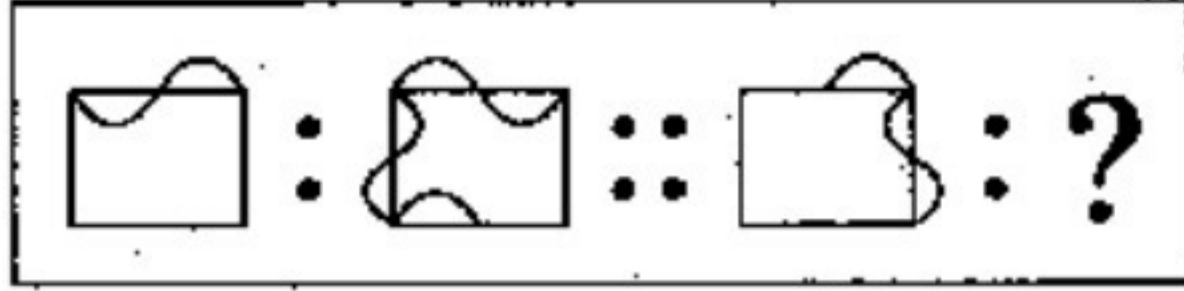

Answer figures :

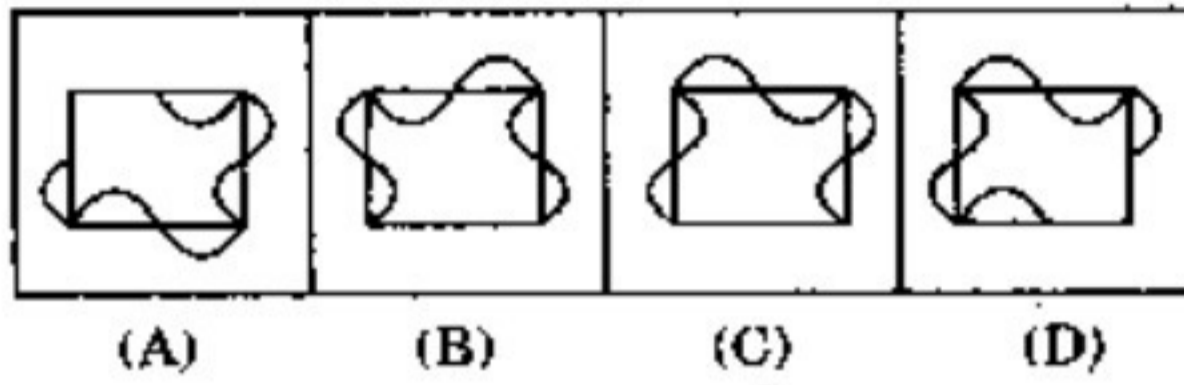

2. Question figures :

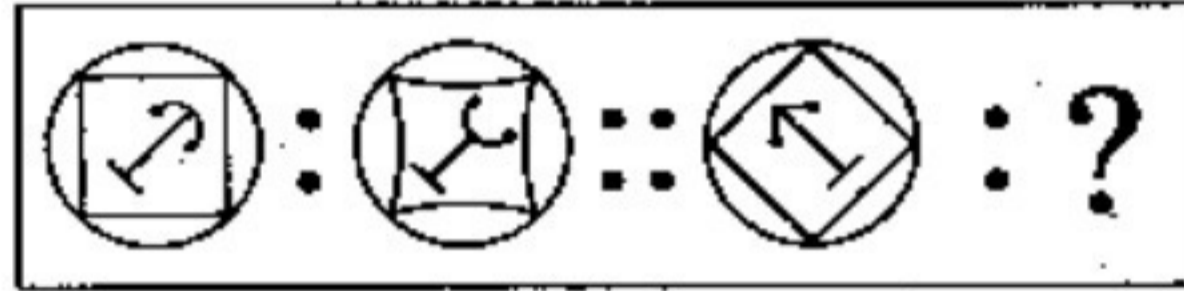

Answer figures :

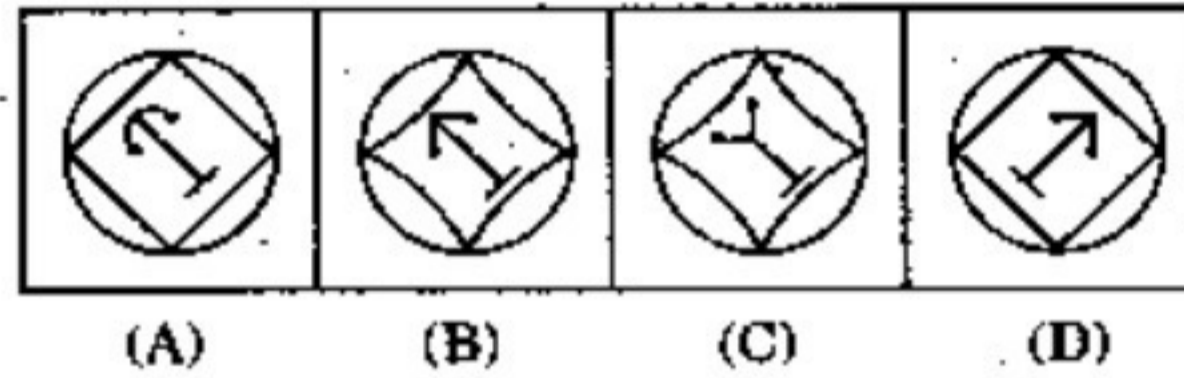

3. Question figures :

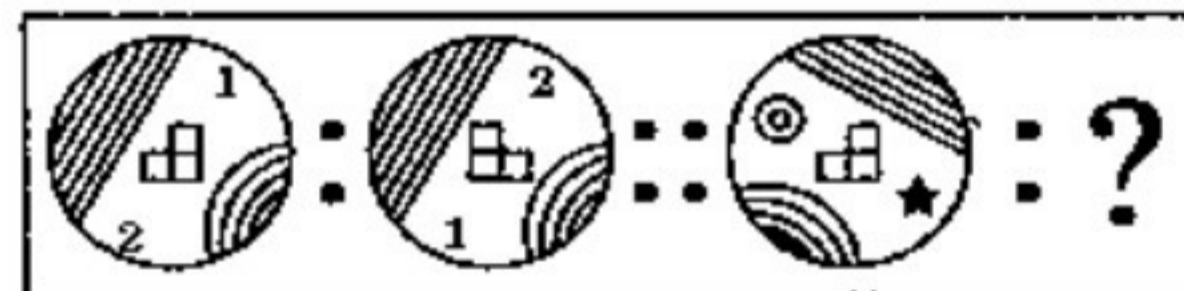

Answer figures :

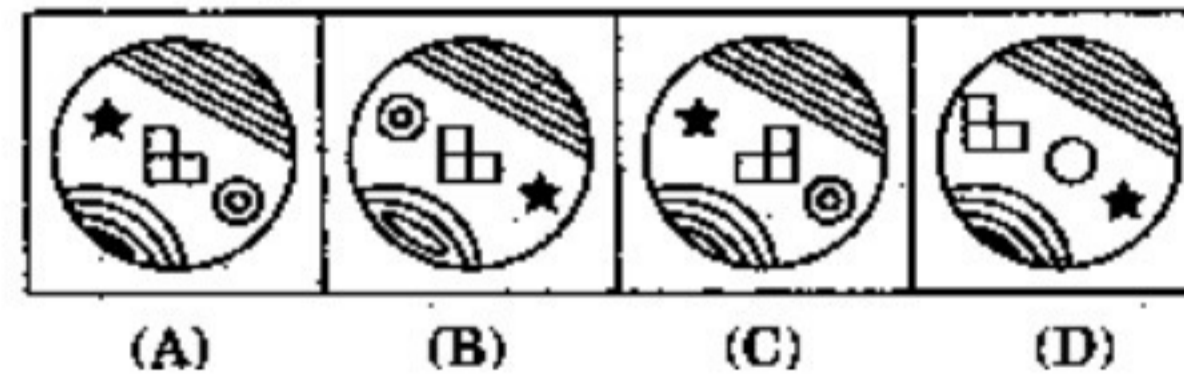

4. $23 : 8 :: 32 : ?$

- (A) 6 (B) 9
(C) 17 (D) 27

5. $MLKJ : NOPQ :: IHGF : ?$

- (A) UTSR (B) RSTU
(C) SRUT (D) UTRS

6. $ACEG : ZXVT :: BDFH : ?$

- (A) YWUS (B) YXWV
(C) YWVT (D) YXVW

7. $BADC : XWZY :: FEHG : ?$

- (A) VXRT (B) TSVU
(C) YXCV (D) VSXW

8. $\frac{5}{9} : \frac{7}{13} :: \frac{10}{19} : ?$

- (A) $\frac{14}{26}$ (B) $\frac{14}{27}$
(C) $\frac{14}{23}$ (D) $\frac{14}{25}$

9. $3 : 9 :: 6 : ?$

- (A) 14 (B) 18
(C) 17 (D) 16

Directions : In questions no. 10 to 18, select the one which is different from the other three responses.

10. (A) 7 - 145 (B) 6 - 108
(C) 5 - 75 (D) 4 - 48

11. (A) Mars (B) Jupiter
(C) Earth (D) Comet

12. (A) Geeta (B) Quran
(C) Bible (D) Mahabharat

13. (A) Message (B) Information
(C) Matter (D) Material

14. (A) Guitar (B) Veena
(C) Flute (D) Sitar

15. (A) 17 - 142 (B) 71 - 34
(C) 41 - 28 (D) 14 - 28
16. (A) 3, 5, 7, 9 (B) 5, 7, 9, 11
(C) 4, 6, 8, 10 (D) 2, 5, 9, 10
17. (A) 8662 (B) 5731
(C) 4628 (D) 2864
18. (A) Tagore (B) Raman
(C) Bhaskara (D) Khurana
19. Arrange the following words in a meaningful order :
- | | |
|-----------------|-------------|
| 1. Grapes | 2. Vineyard |
| 3. Whisky | 4. Brewing |
| 5. Distillation | |
- (A) 2, 1, 5, 4, 3
(B) 3, 5, 4, 2, 1
(C) 2, 1, 4, 3, 5
(D) 2, 1, 4, 5, 3
20. Which will appear fourth in the dictionary ?
(A) Xylophilous
(B) Xylophagus
(C) Xylopyrography
(D) Xylophagan
21. Number of letters skipped in between adjacent letters in the series increases by one. Which of the following series observes the rule given below ?
(A) BEIN (B) CDJO
(C) GJLS (D) QUNZ
22. In the following words, the group of letters should not contain more than three vowels. Which of the following words does *not* conform to the rule ?
(A) SCARCITY
(B) PROGNOSIS
(C) COMPLEXITY
(D) CONVULSION

Directions : In questions no. 23 to 26, choose the correct alternative from the given responses that will complete the series.

23. ?, PSV, EHK, FWZ, ILO
(A) BEH (B) IMP
(C) ACG (D) ADG
24. 78, 86, ?, 88, 82, 90
(A) 76 (B) 84
(C) 83 (D) 80
25. 3 7 13 ? 31 43 57
(A) 51 (B) 81
(C) 41 (D) 21
26. EJOT, INSX, AFKP, ?
(A) CHMS (B) XTOJ
(C) BGLQ (D) EJOT
27. My father has two brothers. The youngest has two sons and one daughter. The elder one has one son and two daughters and the remaining one has three sons. If my father has four nephews, how many cousins (brothers) have I got ?
(A) 6 (B) 4
(C) 7 (D) 5
28. Find the wrong number in the given series.
3, 7, 15, 31, 64, 127
(A) 127 (B) 64
(C) 31 (D) 3
29. A car covers the first half of the distance between two places at 40 km/hr and the second half of the distance at 60 km/hr. So what is the average speed of the car ?
(A) 45 km/hr (B) 48 km/hr
(C) 50 km/hr (D) 60 km/hr

30. In a certain code language, TOGETHER is written as EGTFORETH. How is CONGRATULATE written in that language?

- (A) GRTULTEANOC
(B) GNCOUTRAETLA
(C) GNOCUTARETAL
(D) GLNAOTCEURTA

31. In certain code language, REQUEST is written as S2R52FU. How is RETEST written in that language?

- (A) S2V2RV (B) S2U2RU
(C) S2U2TU (D) S2V2TV

32. Some equations are solved on the basis of a certain system. On the same basis, find out the correct answer for the unsolved equation. If $4^2 = 7$, $5^2 = 7$, $6^2 = 9$, then $7^2 = ?$

- (A) 14 (B) 13
(C) 10 (D) 8

33. Find out the number which belongs to the given group of numbers from the alternatives.

246, 579, 135, 35, 68

- (A) 55 (B) 468
(C) 123 (D) 31

34. If P stands for +, Q stands for \times , R stands for \div , then

$18 Q 12 P 4 R 5 = ?$

- (A) 59 (B) 26
(C) 11.7 (D) 2.33

35. From the given alternatives, select the word which **cannot** be formed using the letters of the given word.

ACCOMPANIED

- (A) PANIC (B) COME
(C) COMB (D) PAIN

Directions : In questions no. 36 and 37, find the missing number from the given responses.

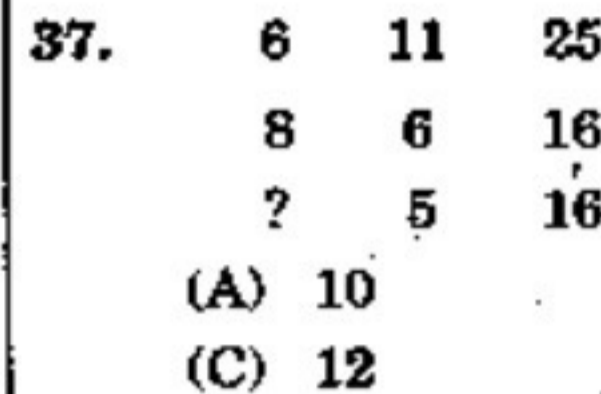
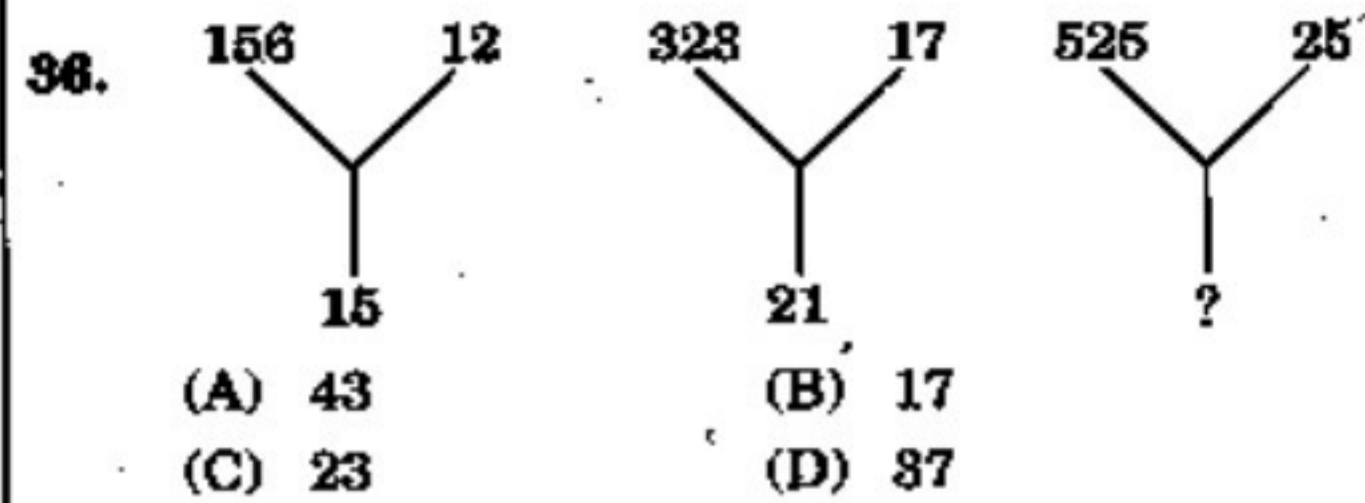

38. Ram travelled 6 ft towards West, he turned left and walked 8 ft, then turned left and walked 4 ft, then turned left and walked 8 ft again. How far is he now from the starting point?

- (A) 8 ft (B) 6 ft
(C) 4 ft (D) 2 ft

39. How many black-faced cubes are there in the given structure?

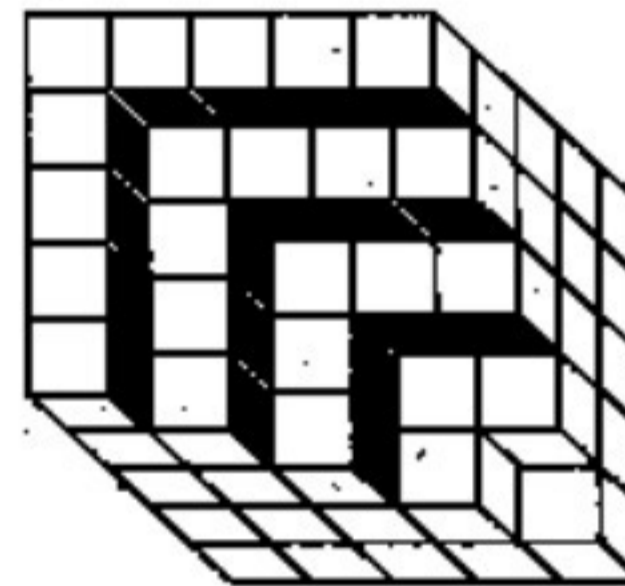

- (A) 75 (B) 55
(C) 25 (D) 15

40. The door of Priya's house faces East. From the back side of the house, she walks straight 50 meters, then turns to the right and walks 50 meters again. Finally, she turns towards the left and stops after walking 25 meters. Now Priya is facing which direction?

- (A) North (B) West
(C) East (D) South

41. In the following diagram, rectangle represents males, circle represents urban and square represents educated. Which region represents educated urban males?

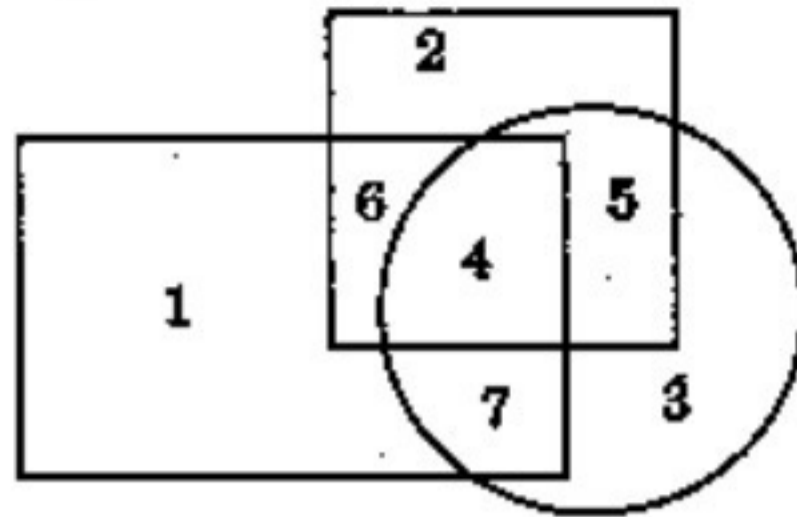

- (A) 5 (B) 4
(C) 6 (D) 7
42. In the following Venn diagram, identify the letter which denotes Film Actors who are Singers but not Directors.

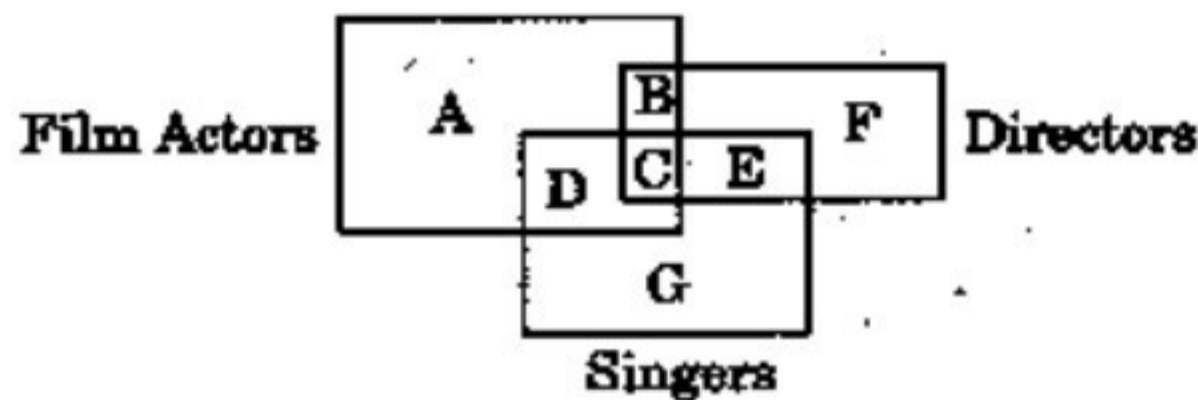

- (A) D (B) C
(C) E (D) F
43. Identify the answer figure from which the pieces given in the question figure have been cut.

Question figure :



Answer figures :

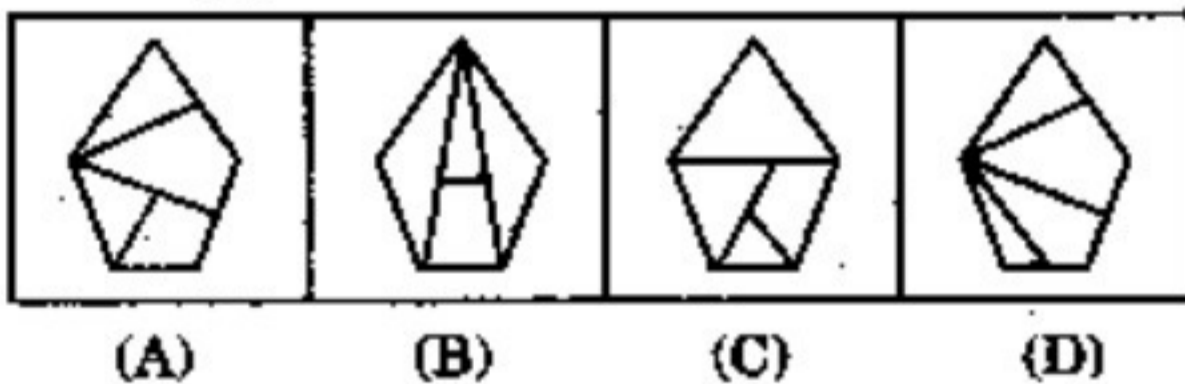

Directions : In questions no. 44 and 45, one or two statements are given, followed by two conclusions I and II. You have to consider the statements to be true even if they seem to be at variance from commonly known facts. You have to decide which of the given conclusions, if any, follows from the given statements.

44. Statement :
A social movement is an interaction of people with a common motivational base in frustration.
Conclusions :
I. In a social movement, people who are satisfied interact with frustrated people.
II. Frustrated people interact with each other in a social movement.
(A) Only conclusion I follows
(B) Only conclusion II follows
(C) Neither conclusion I nor II follows
(D) Both conclusions I and II follow

45. Statements :
All scientists are hard-working. No hard-working man is poor.
Conclusions :
I. No scientist is poor.
II. No poor man is a scientist.
(A) Only conclusion I follows
(B) Only conclusion II follows
(C) Both conclusions I and II follow
(D) None of the conclusions I or II follows

46. Which of the answer figures is exactly the mirror image of the given figure, when the mirror is held on the line AB?

Question figures :



Answer figures :

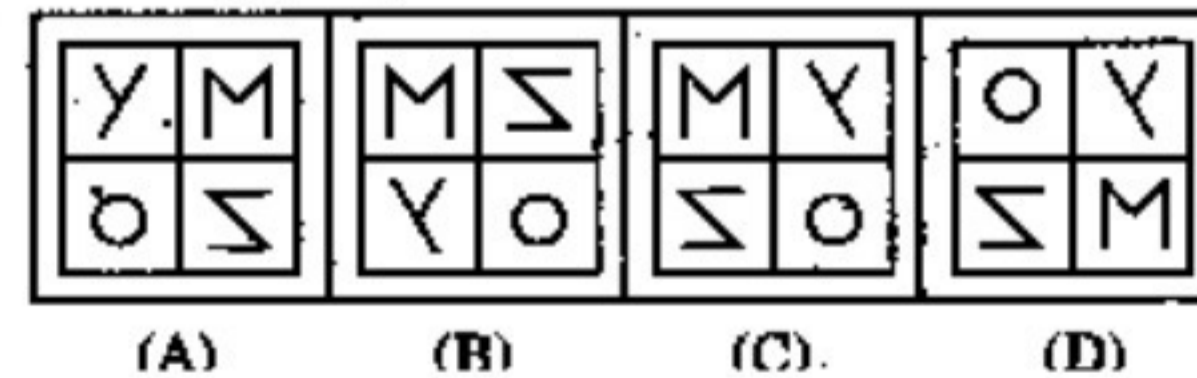

47. A word is represented by only one set of numbers as given in any one of the alternatives. The sets of numbers given in the alternatives are represented by two classes of alphabets as in the two matrices given below. The columns and rows of Matrix I are numbered from 0 to 4 and that of Matrix II are numbered from 5 to 9. A letter from these matrices can be represented first by its row and next by its column, e.g. 'A' can be represented by 13, 76, etc., and 'G' can be represented by 22, 65, etc. Similarly, you have to identify the set for the word 'PUBLIC'.

Matrix I					
	0	1	2	3	4
0	A	U	O	T	B
1	T	E	P	A	W
2	R	M	G	G	I
3	U	M	M	C	L
4	P	L	N	E	C

Matrix II					
	5	6	7	8	9
5	P	T	A	M	E
6	G	I	O	T	M
7	E	A	L	T	M
8	R	A	B	L	T
9	N	P	E	G	P

- (A) 12, 30, 87, 41, 66, 33
- (B) 99, 30, 87, 77, 23, 44
- (C) 55, 01, 87, 98, 34, 87
- (D) 40, 30, 87, 89, 24, 43

48. Components of which of the answer figures will exactly make up the question figure given below.

Question figure :

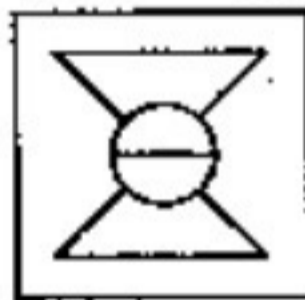

Answer figures :

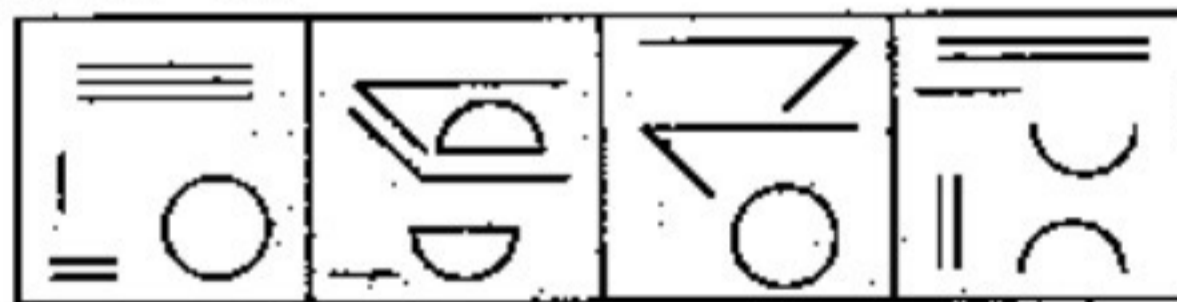

- (A)
- (B)
- (C)
- (D)

49. Select the answer figure in which the question figure is hidden/embedded:

Question figure :



Answer figures :

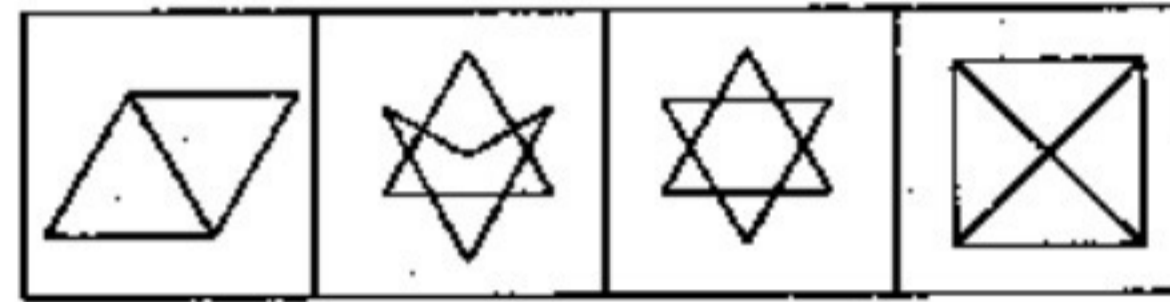

- (A)
- (B)
- (C)
- (D)

50. A piece of paper is folded and punched as shown below in the question figures. From the given answer figures, indicate how it will appear when opened ?

Question figures :

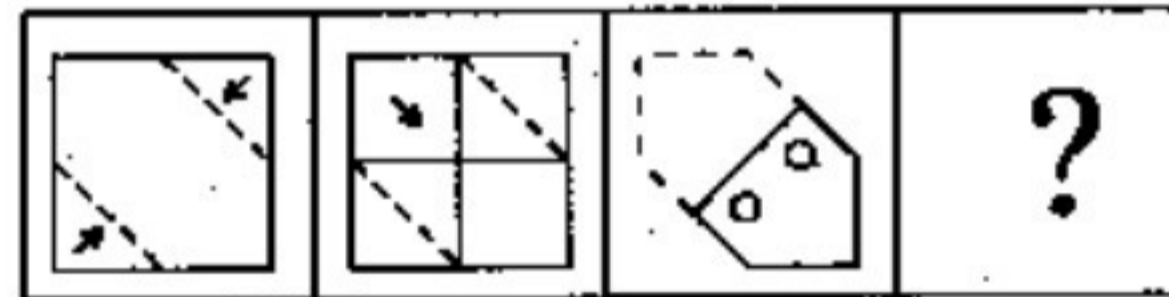

Answer figures :

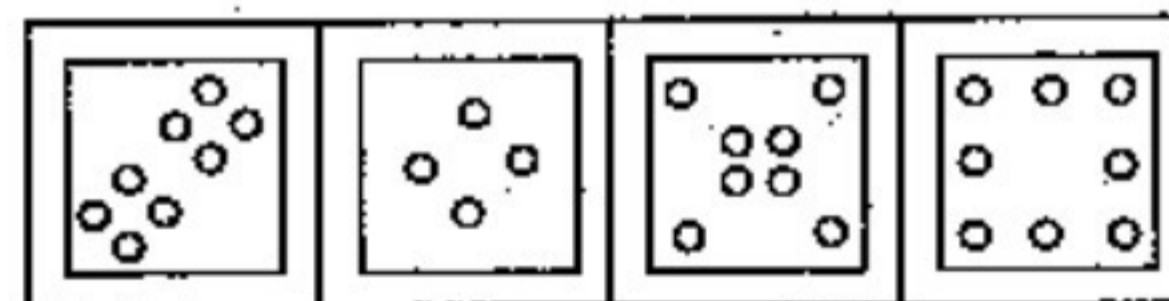

- (A)
- (B)
- (C)
- (D)

TEST (ii) : GENERAL AWARENESS

51. Who was the first economist to have coined the terms "Micro Economics" and "Macro Economics" ?
(A) Milton Friedman
(B) Ragnar Frisch
(C) J.M. Keynes
(D) Paul Samuelson
52. In a free enterprise economy, the decision on what shall be produced is made by
(A) Demand
(B) Income
(C) Price mechanism
(D) Cost
53. The main reason for the high growth of money supply in India since 1970 has been the rise in
(A) Foreign lending
(B) Foreign borrowing
(C) RBI credit to the government
(D) Bank credit to the private sector
54. Who was the first Muslim to be elected as President of the Indian National Congress ?
(A) Syed Ahmad Khan
(B) Agha Khan
(C) Muhammad Ali Jinnah
(D) Badruddin Tyabji
55. Which of the following was *not* known to the Rigvedic period ?
(A) Joint family system
(B) Agriculture
(C) Marriage system
(D) Varna system
56. The characteristic feature of democratic socialism is
(A) Privatization (B) Liberalization
(C) Nationalization (D) Socialization
57. If a group of rich people use power for their selfish goals, it is called as
(A) Monarchy
(B) Oligarchy
(C) Polity
(D) Democracy
58. Who said that "Man is born free and everywhere he is in chains" ?
(A) Locke (B) Aristotle
(C) Marx (D) Rousseau
59. A civil servant in India may exercise political liberty by
(A) joining any political party
(B) contesting in the elections
(C) criticizing the government
(D) exercising his franchise
60. The term 'Law' used in the phrase 'Rule of Law' refers to
(A) Positive law
(B) Natural law
(C) Common law
(D) Conventions of the Constitution
61. The total physical product per unit of a variable input is known as
(A) Average product
(B) Average returns
(C) Average physical product
(D) Average revenue
62. The discount on price when a large quantity is purchased is known as
(A) Volume discount
(B) Maximum discount
(C) Minimum discount
(D) Marginal discount

63. What type of fruit is pineapple ?
(A) Siliqua (B) Sorosis
(C) Syconus (D) Samara
64. Strobilus is a structure associated with
(A) Pca (B) Potato
(C) Pinus (D) Palm
65. Signet-ring is seen in the life cycle of
(A) Mosquito (B) Plasmodium
(C) Entamoeba (D) Giardia
66. The number of occipital condyles in man is
(A) One (B) Two
(C) Three (D) Four
67. Migratory larvae of *Ascaris* produce symptoms of pneumonia. This is known as
(A) Down's syndrome
(B) Klinefelter's syndrome
(C) Turner's syndrome
(D) Loeffler's syndrome
68. Which one of the following animals is an osmoconformer ?
(A) Hagfish (B) Seal
(C) Whale (D) Rohu
69. Which one of the following is the source of Solar energy ?
(A) Nuclear fission
(B) Nuclear fusion
(C) Artificial radioactivity
(D) X-ray emission
70. Who, for the first time, successfully determined the charge of an electron ?
(A) Thomson (B) Millikan
(C) Rutherford (D) Coulomb
71. The first Muslim king who invaded South India was
(A) Balban
(B) Mohammad bin Tughlaq
(C) Babur
(D) Alauddin Khilji
72. The Great Bath was located in
(A) Harappa (B) Mohenjodaro
(C) Lothal (D) Kalibangan
73. The Mughal judicial system was based on
(A) Persian law (B) Hebrew law
(C) Islamic law (D) Indian law
74. Hurricanes are generally
(A) active over the land
(B) travelling in families
(C) dust storms
(D) active over the sea
75. Orinoco oil belt is in
(A) Dubai (B) Saudi Arabia
(C) Venezuela (D) Brazil
76. The highest peak in Africa is
(A) Aconcagua
(B) Kilimanjaro
(C) McKinley
(D) Mount Elbrus
77. A layer of the Earth made up of mixed metals and silicates is called
(A) Sial (B) Sima
(C) Mantle (D) Nife
78. The exhaustion of soil fertility is the result of
(A) Cover cropping
(B) Multiple cropping
(C) Rotation cropping
(D) Over cropping

79. Injection of weakened microbes to confer resistance to a disease is known as
- (A) Transfusion
(B) Vaccination
(C) Inoculation
(D) Intimation
80. Who, among the following, is the author of 'Das-Kapital'?
- (A) Rousseau
(B) Karl Marx
(C) Chanakya
(D) Montesquieu
81. When and where will the next Olympics be held?
- (A) Beijing, 2014
(B) Shanghai, 2012
(C) Rio-de-Janeiro, 2016
(D) Taiwan, 2013
82. A Persian form of singing a poem is called
- (A) Ghazal (B) Qawali
(C) Thumri (D) Bhajan
83. Green-house effect causes
- (A) increase of temperature
(B) increase of moisture in air
(C) decrease of temperature
(D) decrease of moisture in air
84. The advantage of rain-water harvesting is that it
- (A) helps in reducing floods
(B) increases the ground water level
(C) causes more rains
(D) reduces floods and replenishes ground water
85. The 'solder' used for connecting electronic circuits consists of
- (A) Lead and Tin
(B) Tin and Iron
(C) Copper and Lead
(D) Lead and Aluminium
86. What type of molecular motion is responsible for heat conduction?
- (A) Translational
(B) Vibrational
(C) Rotational
(D) Spin
87. Pick the odd one out.
- (A) Compiler
(B) Interpreter
(C) Assembler
(D) Word processor
88. MS-Office is an example of _____
- (A) an operating system
(B) a telecommunication software
(C) a programming language
(D) a productivity software
89. In India, the day 5th September is celebrated as Teacher's Day to honour the birthday of
- (A) Rabindra Nath Tagore
(B) Dr. S. Radhakrishnan
(C) Dr. Rajendra Prasad
(D) Mrs. Indira Gandhi
90. Which among the following polluting agents is responsible for creating a hole in the ozone layer?
- (A) CO (B) CFC
(C) SO₂ (D) CH₄

91. Fly ash is .
- (A) CO₂
 - (B) Organic particulate matter
 - (C) Small ash particles
 - (D) NO_x
92. Addition of chlorine to raw water before treatment is known as
- (A) Plain chlorination
 - (B) Post-chlorination
 - (C) Pre-chlorination
 - (D) Super-chlorination
93. Which of the following is *not* a water treatment technique ?
- (A) Reverse osmosis
 - (B) Ion exchange
 - (C) Electro-dialysis
 - (D) Electrostatic precipitation
94. Which one of the following is a major indoor air pollutant in India ?
- (A) Ozone
 - (B) Peroxy Acetyl Nitrite (PAN)
 - (C) Carbon monoxide
 - (D) Sulphur dioxide
95. Multi Drug Therapy is for the infection of
- (A) Leprosy
 - (B) AIDS
 - (C) Cholera
 - (D) Hepatitis
96. Volvo, the car manufacturing company, introduced
- (A) Alarm
 - (B) Fog light
 - (C) Seat belts
 - (D) Rear view mirrors
97. The Dark Continent is
- (A) Asia
 - (B) Australia
 - (C) Africa
 - (D) Europe
98. The major constituent of air is
- (A) Nitrogen
 - (B) Carbon dioxide
 - (C) Oxygen
 - (D) Hydrogen
99. The souring of milk to curd is an example of
- (A) Saponification
 - (B) Putrefaction
 - (C) Fermentation
 - (D) Esterification
100. Which one of the following compounds is formed when formaldehyde is treated with Grignard reagent ?
- (A) Primary alcohol
 - (B) Secondary alcohol
 - (C) Tertiary alcohol
 - (D) Dihydric alcohol

TEST (iii)
PART - A : GENERAL ENGINEERING
(CIVIL AND STRUCTURAL)

- 101.** The base material for distemper is
(A) Chalk
(B) Lime
(C) Clay
(D) Lime putty
- 102.** The amount of water used in performing setting time test of cement is (assuming p = standard consistency of cement)
(A) $0.60 p$ (B) $0.65 p$
(C) $0.80 p$ (D) $0.85 p$
- 103.** Gypsum used in cement manufacturing acts as
(A) accelerator
(B) air entraining agent
(C) plasticizer
(D) retarder
- 104.** The woodworks should be measured to nearest
(A) $0.001 m$
(B) $0.002 m$
(C) $0.003 m$
(D) $0.004 m$
- 105.** Anti-siphonage pipe is connected to
(A) Main soil pipe
(B) Bottom of P trap W.C.
(C) Top of P trap W.C.
(D) Side of Water Closet
- 106.** For 15 mm thick cement plastering 1 : 6 on 100 sq.m. new brick work, the quantity of cement required is
(A) $0.200 m^3$ (B) $0.247 m^3$
(C) $0.274 m^3$ (D) $0.343 m^3$
- 107.** The most suitable stone for building piers is
(A) granite (B) limestone
(C) marble (D) sandstone
- 108.** Number of modular bricks required for one cubic metre of brick masonry are
(A) 400 (B) 450
(C) 550 (D) 500
- 109.** The plasticity to mould bricks in suitable shape is contributed by
(A) Alumina (B) Lime
(C) Magnesia (D) Silica
- 110.** The crushing strength of a first class brick is
(A) $3 N/mm^2$ (B) $5.5 N/mm^2$
(C) $10.5 N/mm^2$ (D) $7.5 N/mm^2$
- 111.** Which of the following cements is suitable for use in urgent repairs of existing massive concrete structures such as large dams?
(A) Ordinary portland cement
(B) Low heat cement
(C) Rapid hardening cement
(D) Sulphate resisting cement
- 112.** For polishing mosaic floors we use
(A) Carbolic acid (B) Muriatic acid
(C) Acetic acid (D) Oxalic acid
- 113.** The lintels are preferred to arches because
(A) arches require more headroom to span the openings like doors, windows, etc.
(B) arches require strong abutments to withstand arch thrust
(C) arches are difficult in construction
(D) All of the above

114. Ranging is defined as
 (A) measuring the distance from starting point
 (B) establishing intermediate points on a chain line
 (C) the distance between end points
 (D) a point on a chain line
115. Compute the angle between the lines AB and AC, if their respective bearings are $52^{\circ}30'$ and $328^{\circ}45'$.
 (A) $276^{\circ}15'$ (B) $6^{\circ}15'$
 (C) $111^{\circ}15'$ (D) $83^{\circ}45'$
116. The Whole Circle Bearing of a line is $287^{\circ}15'$. The Reduced Bearing of the line is
 (A) S $107^{\circ}15'$ W (B) S $17^{\circ}15'$ W
 (C) N $72^{\circ}45'$ W (D) S $107^{\circ}15'$ E
117. A line joining some fixed points on the main survey lines is called
 (A) check line (B) tie line
 (C) chain line (D) base line
118. Which of the following methods of contouring is most suitable for hilly terrain?
 (A) Direct method
 (B) Square method
 (C) Cross-section method
 (D) Tacheometric method
119. A level line is a
 (A) line parallel to the mean spheroidal surface of the earth
 (B) line passing through centre of cross hairs and centre of eye-piece
 (C) line passing through objective lens and the eye-piece
 (D) horizontal line

120. If 'i' is the rate of interest expressed in decimal and 'n' is the number of years, then coefficient of annual sinking fund, I_c is

(A) $I_c = \frac{[(1+i)^n - 1]}{(1+i) - 1}$

(B) $I_c = \frac{i}{(1+i)^n - 1}$

(C) $I_c = \frac{i}{(1-i)^n + 1}$

(D) $I_c = \frac{i}{(1+i)^n + 1}$

121.

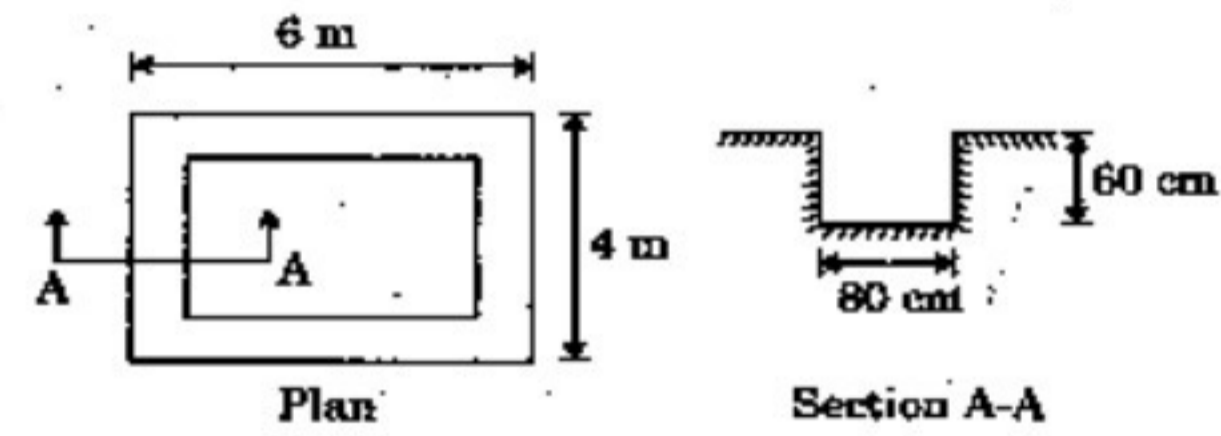

The above figure represents plan and section of an excavation layout. The volume of earthwork in excavation of foundation trench is

- (A) 6.528 cu.m. (B) 8.064 cu.m.
 (C) 8.832 cu.m. (D) 9.600 cu.m.
122. If d be the diameter of MS or tor steel bars in mm, the standard weight (in kg) per metre of the bar is
 (A) $0.00618 d^2$
 (B) $0.00618 d$
 (C) $0.00816 d^2$
 (D) $0.00816 d$
123. The main principle of field surveying is to work from
 (A) higher level to lower level
 (B) lower level to higher level
 (C) part to whole
 (D) whole to part

124. Sand particles are made of
 (A) Kaolinite
 (B) Illite
 (C) Montmorillonite
 (D) Quartz
125. A shallow foundation is defined as a foundation which
 (A) has low bearing capacity
 (B) has a depth of embedment less than its width
 (C) is resting on the ground surface
 (D) causes less settlement
126. If the volume of voids is equal to the volume of solids in a soil mass, then the values of porosity and voids ratio respectively are
 (A) 1.0 and 0.0 (B) 0.0 and 1.0
 (C) 1.5 and 1.0 (D) 1.0 and 0.5
127. The lime stabilization is very effective in treating
 (A) Sandy soils
 (B) Silty soils
 (C) Non-plastic soils
 (D) Plastic clayey soils
128. A 300 mm square bearing plate settles by 15 mm in a plate load test on a cohesive soil when the intensity of loading is 0.2 N/mm^2 . The settlement of a prototype shallow footing 1 m square under the same intensity of loading is
 (A) 15 mm (B) 30 mm
 (C) 50 mm (D) 167 mm
129. The specific speed for a turbine has the dimensions of
 (A) $F^{1/2} L^{-3/4} T^{-3/2}$
 (B) T^{-1}
 (C) $F^{1/2} L^{-5/2} T^{-3/2}$
 (D) $F L^{-3/4} T^{-3/2}$
130. 'Offsets' are
 (A) Lateral measurements from chain line
 (B) Ties or check lines which are perpendicular to chain line
 (C) Sets of minor measurements in chain surveying
 (D) Chain lines which go out of alignment
131. The fore bearings of the lines AB and BC are 40° and 120° respectively. The included angle between AB and BC is
 (A) 40° (B) 60°
 (C) 80° (D) 100°
132. If the sum of northings of a traverse exceeds the sum of southings by 1 m and sum of eastings exceeds the sum of westings by 1 m, the resultant closing error and its true bearing are respectively,
 (A) $\sqrt{2}$ m, N 45° E
 (B) 1 m, N 45° E
 (C) 2 m, N 45° W
 (D) 2 m, N 45° E
133. If in a closed traverse, the sum of the north latitudes is more than the sum of the south latitudes and also the sum of west departures is more than the sum of east departures, the bearing of the closing line is in the
 (A) SE quadrant
 (B) NE quadrant
 (C) NW quadrant
 (D) SW quadrant
134. The angle between true meridian and the magnetic meridian at the time of observations is known as
 (A) Orientation
 (B) Magnetic declination
 (C) Magnetic bearing
 (D) Dip

135. A surge tank is provided in hydropower schemes to
- reduce water hammer pressures
 - reduce frictional losses
 - increase the net head
 - strengthen the penstocks
136. In a two-dimensional flow of fluid, if a velocity potential function ϕ exists which satisfies the relation $\frac{\partial^2 \phi}{\partial x^2} + \frac{\partial^2 \phi}{\partial y^2} = 0$, then the flow is
- steady incompressible
 - steady laminar and incompressible
 - irrotational and incompressible
 - turbulent and incompressible
137. Reynolds number is the ratio of the inertia force to the
- surface tension force
 - viscous force
 - gravity force
 - elastic force
138. A river training work is generally required when the river is
- aggrading type
 - meandering type
 - degrading type
 - both (A) and (C)
139. The water utilizable by plants is available in the form of
- gravity water
 - hydroscopic water
 - capillary water
 - chemical water
140. Bulk modulus of a fluid is the ratio of
- shear stress to shear strain
 - increase in volume to the viscosity of fluid
 - increase in pressure to the volumetric strain
 - critical velocity to the velocity of fluid
141. The buoyancy depends upon the
- pressure with which the liquid is displaced
 - weight of the liquid displaced
 - viscosity of the liquid
 - compressibility of the liquid
142. The discharge over a rectangular notch is
- inversely proportional to $H^{3/2}$
 - directly proportional to $H^{3/2}$
 - inversely proportional to $H^{5/2}$
 - directly proportional to $H^{5/2}$
143. The most economical section of a rectangular channel is one having hydraulic radius equal to
- twice the depth
 - half the breadth
 - half the depth
 - twice the breadth
144. In a rectangular channel, the ratio of the specific energy at critical depth E_c to the critical depth y_c is
- | | |
|---------|----------|
| (A) 2.0 | (B) 1.0 |
| (C) 1.5 | (D) 1.25 |
145. In open channel flows, the characteristic length commonly used in defining the Reynolds number is the
- depth of flow
 - wetted perimeter
 - hydraulic radius
 - area/top width

146. A beam fixed at both ends carries a uniformly distributed load on entire length. The ratio of bending moment at the support to the bending moment at mid span is given by
(A) 0.5 (B) 1.0
(C) 1.5 (D) 2.0
147. In case of biaxial stress, the maximum value of shear stress is given by
(A) Difference of the normal stresses.
(B) Half the difference of the normal stresses
(C) Sum of the normal stresses
(D) Half the sum of the normal stresses
148. From a circular plate of diameter 6.0 cm, a circle is cut out whose diameter is a radius of the plate. The distance of centre of gravity of the remainder from the centre of circular plate is
(A) 2.0 cm
(B) 1.5 cm
(C) 1.0 cm
(D) 0.5 cm
149. In a section undergoing pure bending, the neutral surface is subjected to
(A) compression strain
(B) tensile strain
(C) zero strain
(D) None of the above
150. The ability of a material to absorb energy till the breaking or rupture takes place is known as
(A) Hardness (B) Toughness
(C) Brittleness (D) Softness
151. At the point of contraflexure
(A) Bending moment is minimum
(B) Bending moment is maximum
(C) Bending moment is zero
(D) Bending moment is zero and its sign changes
152. If the stopping distance and average length of a vehicle are 18 m and 6 m respectively, then the theoretical maximum capacity (vehicles per hour) of a traffic lane at a speed of 10 m/sec is
(A) 1500 (B) 2000
(C) 2500 (D) 3000
153. In highway construction on superelevated curves, the rolling shall proceed from
(A) sides towards the centre
(B) centre towards the sides
(C) lower edge towards the upper edge
(D) upper edge towards the lower edge
154. The permissible limit of arsenic in drinking water as per the guidelines of WHO is
(A) 0.01 ppm
(B) 0.01 ppb
(C) 0.05 ppm
(D) 0.05 ppb
155. Which one of the following sequences is the most suitable for treating raw surface water to make it suitable for drinking purpose?
(A) Screening → filtration → sedimentation → disinfection
(B) Screening → disinfection → sedimentation → filtration
(C) Screening → sedimentation → disinfection → filtration
(D) Screening → sedimentation → filtration → disinfection
156. The populations of a town as per census records were 200000, 210000 and 230000 for the years 1981, 1991 and 2001 respectively. The population of the town as per geometric mean method in the year 2009 is
(A) 244872 (B) 245872
(C) 246820 (D) None of the above

157. A simply supported beam is carrying distributed load of 'zero' intensity over one support to linearly varying nature of intensity 'w' over the other support. The shape of BMD will be

- (A) linear
- (B) parabolic
- (C) cubical parabolic
- (D) zero

158. The maximum dimension of a core section for a rectangular cross-section under eccentric loading on a column ($b \times d$) is

- (A) $b/6$
- (B) $d/6$
- (C) $d/8$
- (D) $b/3$ and $d/3$

159. Shear force at the mid-span point D in the following beam is

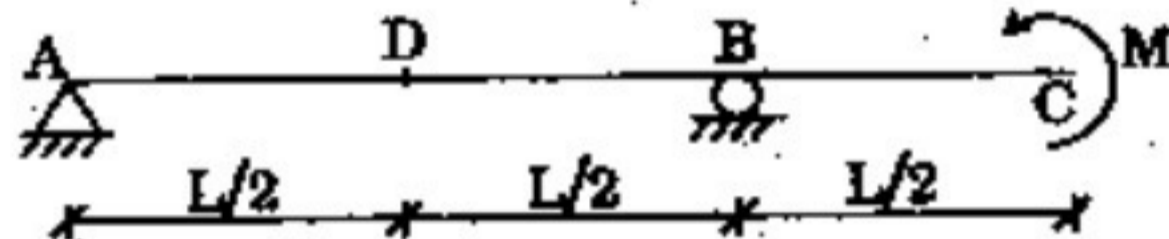

- (A) zero
- (B) $2M/L$
- (C) M/L
- (D) $3M/L$

160. Two identical simply supported beams of span 'l' are subjected to equal load 'W'. One beam is carrying the load 'W' at its centre (as concentrated load) and the other one is carrying it in the form of u.d.l. over the entire span. The ratio of their mid-span bending moment will be

- (A) $\frac{1}{2}$
- (B) 2
- (C) 4
- (D) 8

161. In a Mohr's circle of $\sigma - \tau$ plane ($\sigma =$ normal stress, $\tau =$ shear stress), the vertical diameter represents

- (A) Maximum shear stress
- (B) Maximum normal stress
- (C) Principal stress
- (D) Minimum normal stress

162. The shear diagram for a cantilever beam subjected to a concentrated load at the free end is given by a/an

- (A) Triangle
- (B) Rectangle
- (C) Parabola
- (D) Ellipse

163. Deflection of the free end of a cantilever beam having a concentrated load W at mid span is given by

- (A) $WL^3/3EI$
- (B) $5WL^3/24EI$
- (C) $5WL^3/48EI$
- (D) $WL^3/48EI$

164. Of the several prismatic beams of equal lengths and of same material, the beam that can carry maximum load in flexure is the one having maximum

- (A) Depth of section
- (B) Area of cross-section
- (C) Section modulus
- (D) Moment of inertia

165. The maximum deflection of a simply supported beam of effective span L and subjected to a central concentrated load W is given by

- (A) $WL^3/8EI$
- (B) $WL^3/24EI$
- (C) $WL^3/48EI$
- (D) $5WL^3/384EI$

166. A concentrated load W acts at the centre of a simply supported beam of length L. If the load is changed to a uniformly distributed load over the entire span, then the ratio of maximum deflection under concentrated load and under uniformly distributed load will be

- (A) 1:2
- (B) 1:3
- (C) 1/4
- (D) 8/5

167. The equivalent stiffness of two springs of stiffness S_1 and S_2 joined in series is given by $S =$
- (A) $S_1 S_2 / (S_1 + S_2)$
 (B) $(S_1/S_2) / (S_1 + S_2)$
 (C) $S_1 + S_2$
 (D) $S_1 S_2$
168. Buckling load for an axially loaded column with both ends fixed is given by
- (A) $\pi^2 EI/l^2$ (B) $2 \pi^2 EI/l^2$
 (C) $4 \pi^2 EI/l^2$ (D) $\pi^2 EI/(4 l^2)$
169. Poisson's ratio μ is defined as the ratio of
- (A) axial strain to transverse strain
 (B) axial strain to shear strain
 (C) transverse strain to axial strain
 (D) shear strain to axial strain
170. In a thin cylindrical shell, the ratio of longitudinal stress to hoop stress is
- (A) 0.5 (B) 1.0
 (C) 1.5 (D) 2.0
171. The grade of concrete M 20 means that characteristic compressive strength of 15 cm cubes after 28 days is given by
- (A) 10 N/mm^2 (B) 15 N/mm^2
 (C) 20 N/mm^2 (D) 25 N/mm^2
172. You are asked to construct a massive concrete dam. The type of cement you will use is
- (A) Ordinary portland cement
 (B) Rapid hardening portland cement
 (C) Low heat cement
 (D) Blast furnace slag cement.
173. The object of curing is *not* to
- (A) prevent the loss of water by evaporation
 (B) reduce the shrinkage of cement concrete
 (C) preserve the properties of concrete
 (D) reduce the strength of concrete
174. The initial setting time of Ordinary Portland Cement (OPC) is
- (A) 10 min. (B) 30 min.
 (C) 45 min. (D) 60 min.
175. A structure which offers negligible or zero resistance on bending at any point is known as
- (A) Beam
 (B) Girder
 (C) Lintel
 (D) Cable
176. The curvature at any point $\left(\frac{1}{R}\right)$ along the curve representing the deformed shape of a beam is given by
- (A) $\pm (dy/dx) / \left[1 + \frac{d^2y}{dx^2}\right]^{1/2}$
 (B) $\pm (d^2y/dx^2) / \left[1 + \left(\frac{dy}{dx}\right)^2\right]^{3/2}$
 (C) $\pm (d^2y/dx^2) / \left[1 + \frac{d^2y}{dx^2}\right]^{1/2}$
 (D) $\pm (dy/dx) / \left[1 + \frac{d^2y}{dx^2}\right]^2$
177. The moment required to rotate the near end of a prismatic beam through unit angle, without translation, the far end being fixed is
- (A) EI/L (B) $2 EI/L$
 (C) $3 EI/L$ (D) $4 EI/L$
178. A retaining wall of trapezoidal section having base width 'b' retains earth at its back. For no tension to be developed at base, the resultant force will intersect the base from centre line of the base, within a distance of
- (A) $b/3$ (B) $b/4$
 (C) $b/5$ (D) $b/6$
179. Angle of twist of a circular shaft under the action of a torsional moment T is given by
- (A) GJ/TL (B) TL/GJ
 (C) TJ/GL (D) TG/JL

180. During the manufacture of Portland cement, gypsum or Plaster of Paris is added to
- increase the strength of cement
 - modify the colour of cement
 - reduce heat of hydration of cement
 - adjust setting time of cement
181. Minimum percentage of tension steel in an RCC beam for Fe 500 steel is
- 0.12
 - 0.17
 - 0.22
 - 0.80
182. As per IS 456, the effective length of cantilever shall be taken as
- clear span
 - clear span + effective depth/2
 - clear span + effective depth
 - clear span + effective width
183. If the modular ratio is 'm', stress ratio in steel and concrete is 'r', then the critical neutral axis constant 'k' is given by
- $m/(m-r)$
 - $m/(m+r)$
 - $(m+r)/m$
 - m^2/r
184. For two way action, i.e. punching shear, the calculated shear stress, τ_v , should satisfy the following relation $\tau_v \leq k_s \tau_c$, where τ_c according to working stress method is expressed as
- $0.1 \sqrt{f_{ck}}$
 - $0.16 \sqrt{f_{ck}}$
 - $0.25 \sqrt{f_{ck}}$
 - $0.4 \sqrt{f_{ck}}$
185. The minimum horizontal distance between two main reinforcement bars should be
- diameter of larger bar or 5 mm more than the nominal maximum size of coarse aggregate, whichever is higher
 - 5 mm more than the nominal size of the aggregate only
 - 5 mm more than the diameter of the bar
 - None of the above
186. High percentage of C_3S and low percentage of C_2S in a cement will result in
- rapid hardening
 - high early strength with high heat generation
 - more resistance to chemical attack
- The correct answer is
- Only (i)
 - Only (iii)
 - Both (i) and (ii)
 - Both (ii) and (iii)
187. As per IS 456, splitting tensile strength (f_{cr}) of concrete may be estimated from compressive strength as
- $f_{cr} = 0.65 \sqrt{f_{ck}}$
 - $f_{cr} = 0.7 \sqrt{f_{ck}}$
 - $f_{cr} = 0.75 \sqrt{f_{ck}}$
 - $f_{cr} = 0.8 \sqrt{f_{ck}}$
188. Maximum admissible water-cement ratio for mild environmental exposure should be
- 0.55
 - 0.50
 - 0.45
 - 0.40
189. Air entrainment in the concrete increases
- workability
 - strength
 - the effect of temperature variation
 - the unit weight
190. Which of the following is added for quick setting of cement?
- Gypsum
 - Alum
 - Zinc sulphate
 - Aluminium sulphate

191. The distance between two rivets measured perpendicular to the direction of applied force is known as
- (A) pitch
(B) gauge
(C) staggered pitch
(D) edge distance
192. For simply supported beams, the allowable deflection shall not exceed
- (A) 1/325 of span
(B) 1/350 of span
(C) 1/375 of span
(D) 1/400 of span
193. The beams supporting the stair steps, are generally known as
- (A) headers
(B) trimmers
(C) stringers
(D) spandrel beam
194. Maximum size of a fillet weld for a plate of square edge is
- (A) 1.5 mm less than the thickness of the plate
(B) one-half of the thickness of the plate
(C) thickness of the plate itself
(D) 1.5 mm more than the thickness of the plate
195. The minimum edge and end distance from the centre of any hole to the nearest flame-cut edge shall not be less than
- (A) 1.5 times hole dia
(B) 1.7 times hole dia
(C) 2 times hole dia
(D) 1.5 times bolt / rivet dia
196. In a singly reinforced beam, if the permissible stress in concrete reaches earlier than the permissible stress in steel, the beam section is called
- (A) Under reinforced section
(B) Over reinforced section
(C) Balanced section
(D) Economic section
197. If σ_s is the stress in bar and τ_{bd} is the design bond stress, then the development length of a bar of diameter ϕ is given by
- (A) $\frac{4\phi \sigma_s}{\tau_{bd}}$ (B) $\frac{\phi \sigma_s}{4\tau_{bd}}$
(C) $\frac{2\phi \sigma_s}{3\tau_{bd}}$ (D) $\frac{\phi \sigma_s}{3\tau_{bd}}$
198. Side face reinforcement shall be provided in the reinforced concrete beam when depth of web in the beam exceeds
- (A) 500 mm (B) 750 mm
(C) 1000 mm (D) 1200 mm
199. A cantilever retaining wall should not be used for heights more than
- (A) 4 m (B) 6 m
(C) 8 m (D) 10 m
200. Diagonal tension in a reinforced concrete beam
- (A) is maximum at neutral axis
(B) decreases below neutral axis and increases above neutral axis
(C) increases below neutral axis and decreases above neutral axis
(D) remains constant throughout the depth

TEST (iii)
PART - B : GENERAL ENGINEERING
(ELECTRICAL)

101. The voltage wave $v = V_m \sin(\omega t - 15^\circ)$ volts is applied across an ac circuit. If the current leads the voltage by 10° and the maximum value of current is I_m , then the equation of current is
- (A) $i = I_m \sin(\omega t + 5^\circ)$ amps
 (B) $i = I_m \sin(\omega t - 25^\circ)$ amps
 (C) $i = I_m \sin(\omega t + 25^\circ)$ amps
 (D) $i = I_m \sin(\omega t - 5^\circ)$ amps
102. The average value of current (I_{av}) of a sinusoidal wave of peak value (I_m) is
- (A) $I_{av} = \frac{I_m}{2}$ (B) $I_{av} = \frac{\pi}{2} I_m$
 (C) $I_{av} = \frac{2}{\pi} I_m$ (D) $I_{av} = \frac{I_m}{\sqrt{2}}$
103. The emf induced in a coil is given by
- $$e = -N \frac{d\phi}{dt}$$
- where e is the emf induced, N is the number of turns and $d\phi$ is the instantaneous flux linkage with the coil in time dt .
 The negative sign in the expression is due to
- (A) Hans Christian Oersted
 (B) Andre-Marie Ampere
 (C) Michael Faraday
 (D) Emil Lenz
104. The mutual inductance between two coils having self inductances 3 henry and 12 henry and coupling coefficient 0.85 is
- (A) 12.75 henry
 (B) 5.1 henry
 (C) 0.425 henry
 (D) 1.7 henry
105. Resistance temperature coefficient of copper at 20°C is
- (A) $0.0045/^\circ\text{C}$
 (B) $0.0017/^\circ\text{C}$
 (C) $0.00393/^\circ\text{C}$
 (D) $0.0038/^\circ\text{C}$
106. The load characteristic of dc shunt generator is determined by
- (A) the voltage drop in armature resistance.
 (B) the voltage drop due to armature reaction, voltage drop due to decreased field current and voltage drop in armature resistance.
 (C) the voltage drop due to armature reaction and voltage drop in armature resistance.
 (D) the voltage drop due to armature reaction, voltage drop due to decreased field current and voltage drops in armature resistance and field resistance.
107. How many watt-seconds are supplied by a motor developing 2 hp (British) for 5 hours?
- (A) 2.6856×10^7 watt-seconds
 (B) 4.476×10^6 watt-seconds
 (C) 2.646×10^7 watt-seconds
 (D) 6.3943×10^6 watt-seconds
108. A 4-pole generator is running at 1200 rpm. The frequency and time period of the emf generated in its coils are respectively
- (A) 50 Hz, 0.02 sec.
 (B) 40 Hz, 0.025 sec.
 (C) 300 Hz, 0.00333 sec.
 (D) 2400 Hz, $\frac{1}{2400}$ sec.

109. The single phase Induction Motor (IM) which does not have centrifugal switch is
- (A) capacitor start single phase IM
 - (B) resistance split single phase IM
 - (C) capacitor start capacitor run single phase IM
 - (D) permanent capacitor run single phase IM

110. When a multiplier is added to an existing voltmeter for extending its range, its electromagnetic damping
- (A) remains unaffected
 - (B) increases
 - (C) decreases
 - (D) changes by an amount depending on the controlling torque

111. Phasor diagram of load voltage (V), current in pressure coil (I_p) and current in current coil (I_c) is shown in the figure when an electrodynamic wattmeter is used to measure power. The reading of the wattmeter will be proportional to

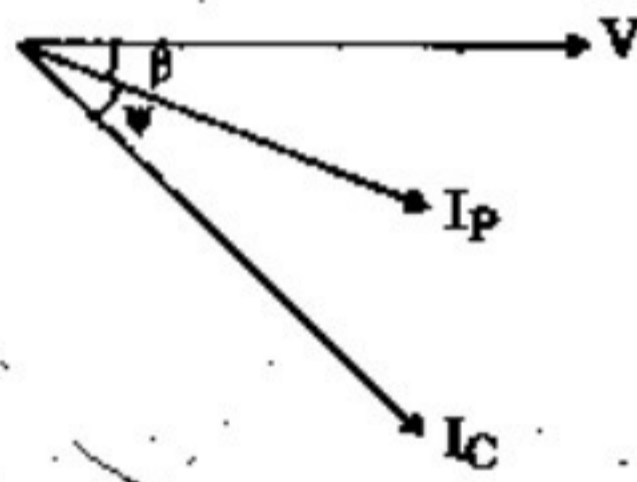

- (A) $\cos(\beta + \psi)$
- (B) $\cos \psi$
- (C) $\cos \beta \cos \psi$
- (D) $\cos \beta \cos(\beta + \psi)$

112. Two parallel conductors carrying current in opposite directions will exert on each other
- (A) an attractive force
 - (B) a repulsive force
 - (C) an axial force
 - (D) no force

113. The unit of reluctance of magnetic circuit is
- (A) AT/m
 - (B) Weber/m
 - (C) AT/Weber
 - (D) Weber/AT

114. In indicating instruments the springs are mainly used to
- (A) conduct the current to the coils
 - (B) hold the pivot in position
 - (C) control the pointer movement
 - (D) reduce the vibration of the pointer

115. A balanced 3-phase, 3-wire supply feeds balanced star connected resistors. If one of the resistors is disconnected, then the percentage reduction in load will be
- (A) 33.33
 - (B) 50
 - (C) 66.67
 - (D) 75

116. The total flux at the end of a long permanent bar magnet is 100×10^{-6} Wb. The end of this magnet is withdrawn through a 1000 turn coil in $\frac{1}{20}$ seconds. The induced e.m.f. in the coil is
- (A) 20.0 V
 - (B) 2.0 V
 - (C) 0.2 V
 - (D) 0.02 V

117. In reference to the figure, the voltage waveform $v(t)$ is measured by a PMMC, a PMMC combined with bridge rectifier and a moving iron (MI) instrument. Two lists are prepared thereafter :

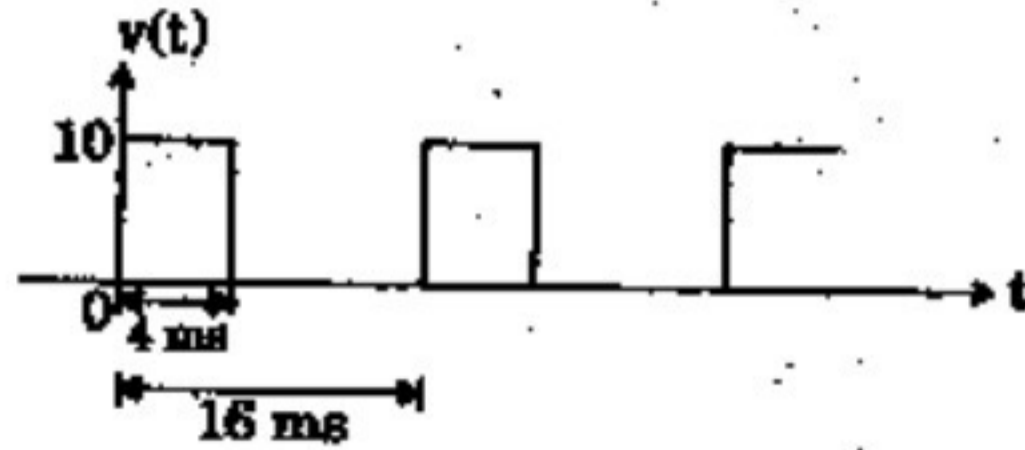

Instrument list	List of instrument reading
a. PMMC	i. 5 V
b. PMMC rectifier	ii. 2.75 V
c. M.I.	iii. 2.5 V

The correct option relating the instruments and their reading is

- (A) a-i, b-ii, c-iii
- (B) a-iii, b-ii, c-i
- (C) a-ii, b-iii, c-i
- (D) a-iii, b-i, c-ii

118. The switching transistor as shown, carries in the collector side an rms current of 8 mA. If the frequency of rectangular pulse train v_i is 50 Hz, then on-time of the transistor is

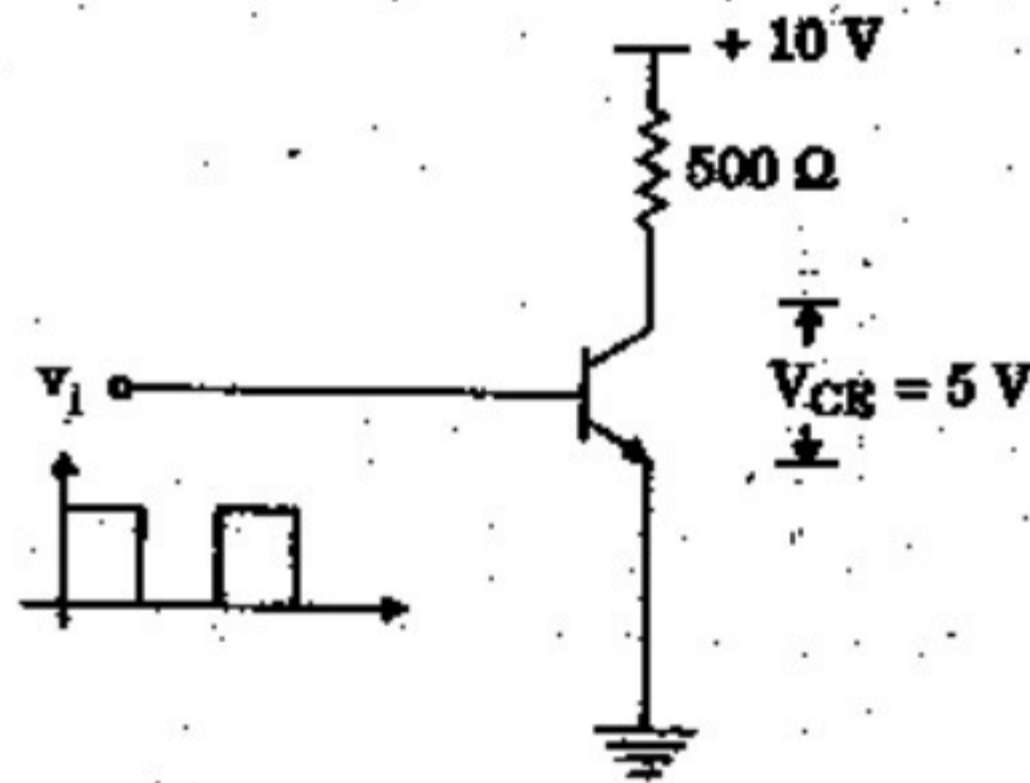

- (A) 20 ms
- (B) 6.4 ms
- (C) 12.8 ms
- (D) 16 ms

119. An ammeter of resistance R_m is placed in an arrangement as shown in the figure. Material of R_m, R_{sh} is copper whereas that of R_s, R_x is manganin. The condition for which the meter performance is compensated against temperature, is

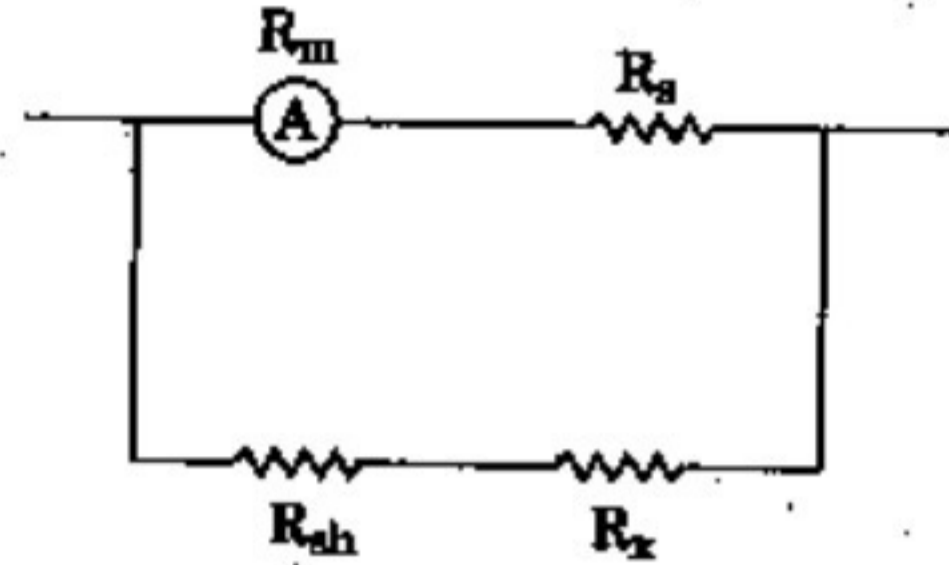

- (A) $\frac{1}{R_m} + \frac{1}{R_{sh}} = \frac{1}{R_s} + \frac{1}{R_x}$
- (B) $R_m R_s = R_{sh} R_x$
- (C) $R_m + R_s = R_{sh} + R_x$
- (D) $\frac{R_m}{R_s} = \frac{R_{sh}}{R_x}$

120. If a 110 V, 50 Hz is applied across a PMMC voltmeter of full-scale range 0 - 220 V and internal resistance of 10 k Ω , reading of the voltmeter will be

- (A) 0 V
- (B) $110\sqrt{2}$ V
- (C) 78 V
- (D) 55 V

121. To maximize the driving torque in an induction type instrument, flux produced by shunt coil and series coil should be

- (A) in phase with each other
- (B) in quadrature with each other
- (C) displaced by 45° with respect to each other
- (D) out of phase with respect to each other

122. To minimize the errors due to lead and contact resistances, low resistances used in electrical measurement work are provided with

- (A) guard rings
- (B) four terminals
- (C) thick insulation
- (D) metal shields

123. Examine the two statements 'A' and 'R' and select your answer.

Statement A :

Switching of a lamp in house produces noise in a radio.

Statement R :

Switching operation produces arc across separating contacts.

- (A) Both A and R are true and R is a correct explanation of A.
(B) Both A and R are true and R is not a correct explanation of A.
(C) A is true but R is false
(D) A is false but R is true

124. The small pockets of air in the high voltage cable provide _____ relative permittivity, _____ electric field and at these sites breakdown is likely to be initiated.

- (A) high, high (B) low, low
(C) low, high (D) high, low

125. The capacitance measured between any two cores of a 3-core cable with the sheath earthed is $3 \mu\text{F}$. The capacitance per phase will be

- (A) $1.5 \mu\text{F}$ (B) $6 \mu\text{F}$
(C) $1 \mu\text{F}$ (D) None of the above

126. In an insulated cable having core diameter d and overall diameter D , the ratio of maximum to minimum dielectric stress is given by

- (A) $(D/d)^{1/2}$ (B) $(D/d)^2$
(C) D/d (D) d/D

127. Compared to the breaking capacity of a circuit breaker, its making capacity should be

- (A) more
(B) less
(C) equal
(D) the two are unrelated to each other

128. In electronic circuits, for blocking the DC component of a voltage signal, a/an _____ is connected in series with the voltage source.

- (A) capacitor (B) diode
(C) resistor (D) inductor

129. For n-type semiconductor, the doping material is

- (A) tetravalent (B) pentavalent
(C) trivalent (D) bivalent

130. An attenuator probe as shown, is connected to an amplifier of input capacitance $0.1 \mu\text{F}$. Value of C that must be connected across 100 k to make the overall gain independent of frequency, is

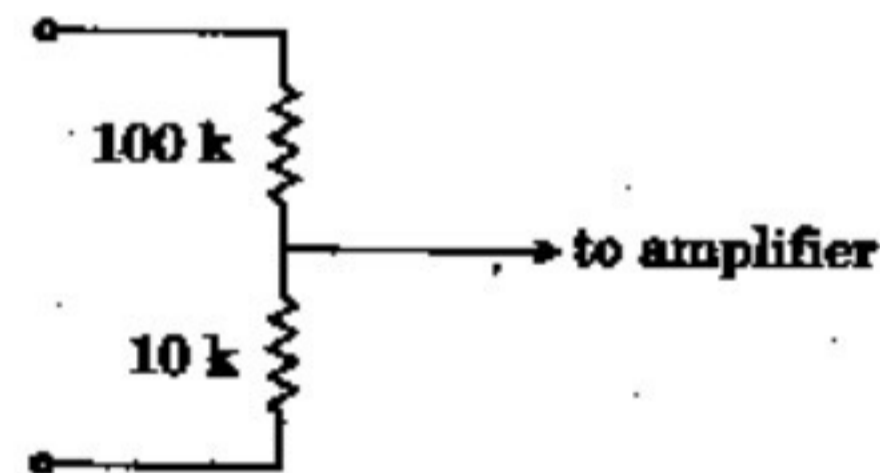

- (A) $0.01 \mu\text{F}$ (B) $0.1 \mu\text{F}$
(C) $1 \mu\text{F}$ (D) $10 \mu\text{F}$

131. Silicon content in iron lamination is kept within 5% as it

- (A) makes the material brittle
(B) reduces the curie point
(C) increases hysteresis loss
(D) increases cost

132. A wattmeter is marked $15 \text{ A} / 30 \text{ A}$, $300 \text{ V} / 600 \text{ V}$ and its scale is marked up to 4500 watts. When the meter is connected for 30 A , 600 V , the point indicated 2000 watts. The actual power in the circuit is

- (A) 2000 watts (B) 4000 watts
(C) 6000 watts (D) 8000 watts

133. Resistance switching is normally employed in

- (A) bulk oil breakers
- (B) minimum oil breakers
- (C) air blast circuit breakers
- (D) all of A, B and C

134. If the angular frequency of an alternating voltage is ω , then the angular frequency of instantaneous real power absorbed in an ac circuit is

- (A) 2ω
- (B) ω
- (C) 3ω
- (D) $\omega/2$

135. If the transistor having $V_{CE} = 5\text{ V}$, $V_{BE} = 0.7\text{ V}$ has $\beta = 45$, value of R is

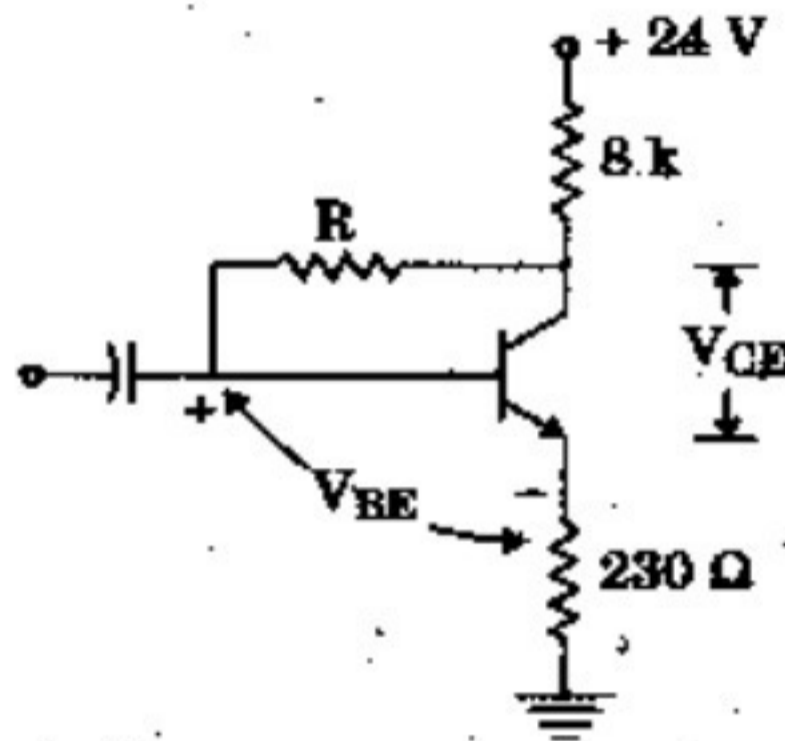

- (A) 85.64 k
- (B) 63.14 k
- (C) 72.15 k
- (D) 91.18 k

136. In a balanced 3-phase circuit, the line current is 12 A. When the power is measured by two wattmeter method, one meter reads 11 kW while the other reads zero. Power factor of the load is

- (A) 0
- (B) 0.5
- (C) 0.866
- (D) 1.0

137. In case of frosted GLS lamps, frosting is done by

- (A) acid etching
- (B) ammonia
- (C) ozone
- (D) salt water

138. If the supply polarity to the armature terminals of a separately excited d.c. motor is reversed, the motor will run under

- (A) Plugging condition
- (B) Regenerative braking condition
- (C) Dynamic braking condition
- (D) Normal motoring condition

139. For welding purpose, the secondary of transformer used should be capable of carrying

- (A) high voltage, high current
- (B) high voltage, low current
- (C) low voltage, high current
- (D) low voltage, low current

140. Which of the following is correct ?

- (A) Load factor = capacity factor \times utilisation factor
- (B) Utilisation factor = capacity factor \times load factor
- (C) Capacity factor = load factor \times utilisation factor
- (D) Load factor has no relation with capacity factor and utilisation factor

141. In a motor starter, the electromechanical contactor provides inherent protection against

- (A) over-current
- (B) short-circuit
- (C) single-phasing
- (D) under-voltage

142. In the circuit, v is the input voltage applied across the capacitor of 2 F. Current through the capacitor is

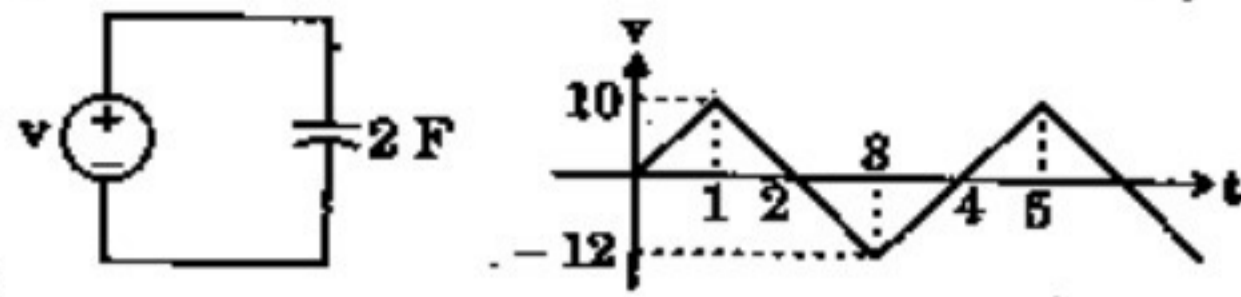

- (A)
- (B)
- (C)
- (D)

143. In a semiconductor, the resistivity

(A) depends on temperature
(B) depends on voltage
(C) depends on current through it
(D) None of the above

144. A geyser is operated from 230 V, 50 c/s mains. The frequency of instantaneous power consumed by the geyser is

(A) 25 c/s (B) 50 c/s
(C) 100 c/s (D) 150 c/s

145. Ampere-second is the unit of

(A) emf (B) power
(C) electric charge (D) energy

146. Two lossy capacitors with equal capacitance values and power factors of 0.01 and 0.02 are in parallel, and the combination is supplied from a sinusoidal voltage source. The power factor of the combination is

- (A) 0.03 (B) 0.015
(C) 0.01 (D) 0.0002

147. A voltmeter when connected across a dc supply, reads 124 V. When a series combination of the voltmeter and an unknown resistance X is connected across the supply, the meter reads 4 V. If the resistance of the voltmeter is 50 kΩ, the value of X is

- (A) 1550 kΩ (B) 1600 kΩ
(C) 1.6 kΩ (D) 1.5 MΩ

148. The purpose of providing a choke in the tube-light is

- (A) to eliminate the corona effects
(B) to avoid radio interference
(C) to improve power factor
(D) to limit current to appropriate value

149. In a 3-phase 400 V, 4-wire system, two incandescent lamps, one having 230 V, 100 W specification and the other 230 V, 200 W are connected between R phase-neutral and Y phase-neutral respectively. If the neutral wire breaks

- (A) 100 W lamp will fuse first
(B) 200 W lamp will fuse first
(C) both the lamps will fuse together
(D) both the lamps will glow

150. A solenoid of inductance 250 mH and resistance 10 Ω is connected to a battery. The time taken for the magnetic energy to reach $\frac{1}{4}$ th of its maximum value is

- (A) $\log_e(2)$ (B) $10^{-3} \log_e(2)$
(C) $25 \log_e(2)$ (D) $\frac{1}{40} \log_e(2)$

151. The peak value of the output voltage of a half-wave rectifier is 100 V. The r.m.s. value of the half-wave rectifier output voltage will be

- (A) 100 V (B) 50 V
(C) 70.7 V (D) 35.35 V

152. The given circuit represents a

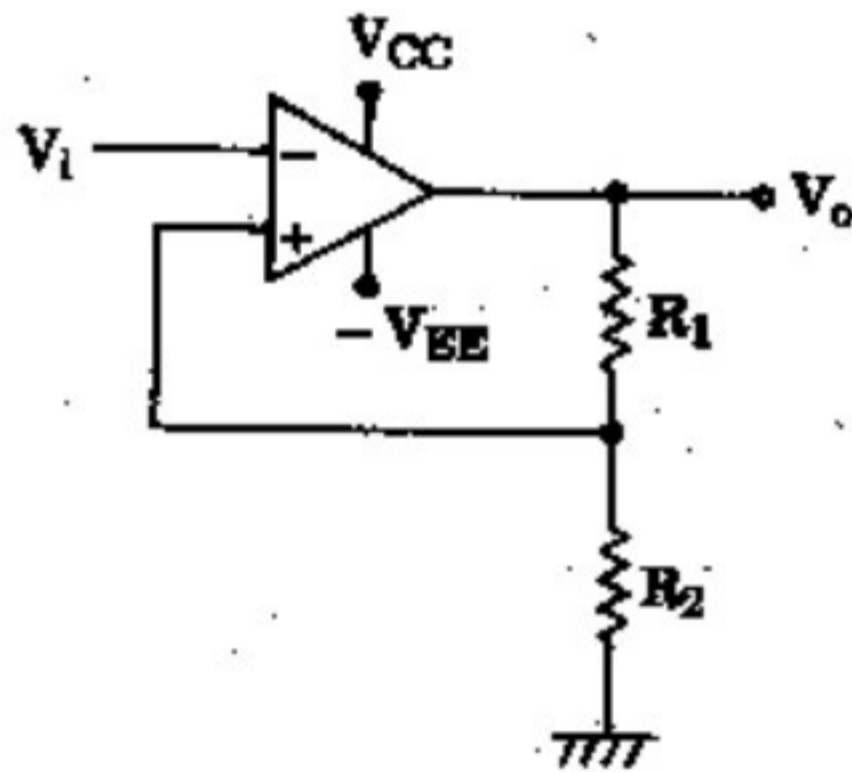

- (A) monostable multivibrator
(B) astable multivibrator
(C) Schmitt trigger
(D) bistable multivibrator

153. The input resistance of a FET is of the order of

- (A) 100 Ω (B) 10 k Ω
(C) 1 M Ω (D) 100 M Ω

154. In a series R-L circuit supplied from a sinusoidal voltage source, voltage across R and L are 3 V and 4 V respectively. The supply voltage is then

- (A) 7 V (B) 1 V
(C) 3.5 V (D) 5 V

155. If the insulation resistance of 2 m long sample of a cable is 10 M Ω , then a 8 m long sample of the same will have an insulation resistance of

- (A) 40 M Ω (B) 2.5 M Ω
(C) 2 M Ω (D) 5.5 M Ω

156. An inductor is supplied from a sinusoidal voltage source. The magnetic field energy in the inductor changes from peak value to minimum value in 10 msec. The supply frequency is

- (A) 50 Hz (B) 25 Hz
(C) 1 kHz (D) 100 Hz

157. Two 2000 Ω , 2 watt resistors are connected in parallel. Their combined resistance value and wattage rating are

- (A) 1000 Ω , 2 watt (B) 1000 Ω , 4 watt
(C) 2000 Ω , 4 watt (D) 2000 Ω , 2 watt

158. We have three resistances each of value 1 Ω , 2 Ω and 3 Ω . If all the three resistances are to be connected in a circuit, how many different values of equivalent resistance are possible?

- (A) Five (B) Six
(C) Seven (D) Eight

159. One B.O.T. unit is

- (A) 1000 kWh (B) 10 kWh
(C) 1 kWh (D) 0.1 kWh

160. An electric heater draws 1000 watts from a 250 V source. The power drawn from a 200 V source is

- (A) 800 W (B) 640 W
(C) 1000 W (D) 1562.5 W

161. Three 3 μ F capacitors are in series. A 6 μ F capacitor is in parallel with this series arrangement. The equivalent capacitance of this combination is

- (A) 7 μ F (B) 15 μ F
(C) 3.6 μ F (D) 1 μ F

162. A dc series motor has an armature resistance of 0.06Ω and series field resistance of 0.08Ω . The motor is connected to a 400 V supply. The line current is 20 A when the speed of the machine is 1100 rpm. When the line current is 50 A and the excitation is increased by 30%, speed of the machine in rpm is
- (A) 1100 (B) 1003
(C) 837 (D) 938

163. The voltage across R, L and C are 8 V, 14 V and 10 V respectively as in the figure. If the voltage source is sinusoidal, then the input voltage (r.m.s.) is

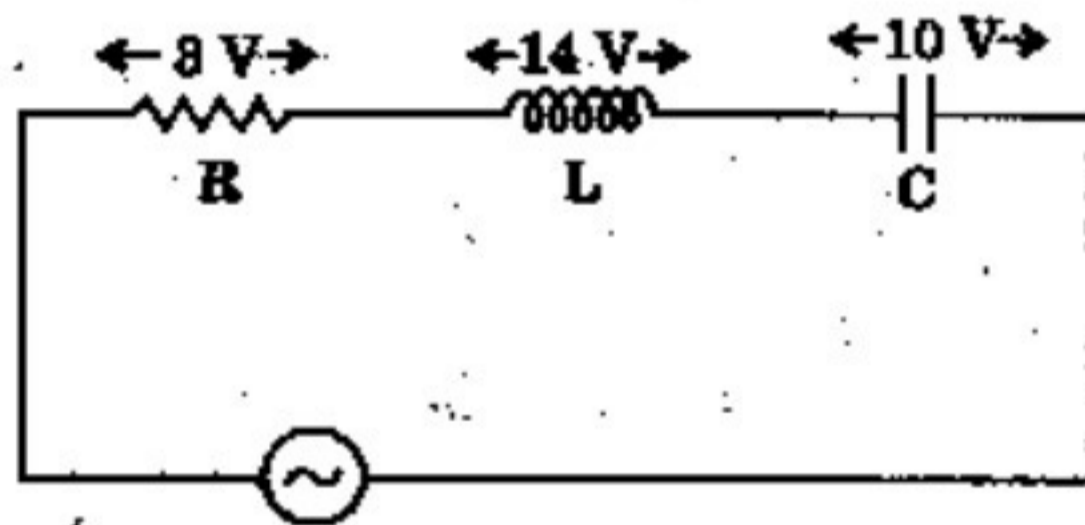

- (A) 10 V (B) 5 V
(C) 2.5 V (D) 15 V
164. In 1-phase series RL circuit fed by voltage source, the resistance and reactance values are 4 ohm each. In this circuit
- (A) the current leads the voltage by 45°
(B) the current lags the voltage by 45°
(C) the current lags the voltage by 60°
(D) None of the above
165. Superposition theorem requires as many circuits to be solved as there are
- (A) nodes
(B) sources
(C) loops
(D) None of the above

166. In squirrel-cage induction motor, the rotor conductors are
- (A) open circuited.
(B) short circuited via end rings.
(C) short circuited via external reactance.
(D) short circuited via external resistance.
167. A 3-phase synchronous motor is started by utilizing the torque developed in
- (A) the high-speed steam-turbine.
(B) the damper winding on the rotor.
(C) the damper winding on the stator.
(D) the low-speed water-turbine.
168. If the frequency of input voltage of a transformer is increased keeping the magnitude of the voltage unchanged, then
- (A) both hysteresis loss and eddy current loss in the core will increase.
(B) hysteresis loss will increase but eddy current loss will decrease.
(C) hysteresis loss will increase but eddy current loss will remain unchanged.
(D) hysteresis loss will decrease but eddy current loss will increase.
169. Two single-phase ac motors A and B operate from a 1000 V supply. A consumes 2 kW at a power factor of 0.8 (lagging) and B consumes 1 kW at a power factor of 0.5 (lagging). The total current drawn from the supply is approximately
- (A) 4.5 A (B) 2.1 A
(C) 4.41 A (D) 9 A
170. The high-voltage and low-voltage winding resistances of a distribution transformer of 100 KVA, 1100/220 volts, 50 Hz are 0.1Ω and 0.004Ω respectively. The equivalent resistances referred to high-voltage side and low-voltage side are respectively
- (A) 2.504Ω and 0.2Ω
(B) 0.2Ω and 0.008Ω
(C) 0.10016Ω and 2.504Ω
(D) 0.008Ω and 0.10016Ω

171. A tank circuit consists of
- (A) an inductor and a capacitor connected in series
 - (B) an inductor and a capacitor connected in parallel
 - (C) a pure inductance and a pure capacitance connected in series
 - (D) a pure inductance and a pure capacitance connected in parallel

172. The instantaneous power of a 1-phase series circuit supplying R-L load from a sinusoidal voltage source has in each cycle
- (A) negative twice, zero four times
 - (B) zero twice, negative once
 - (C) negative four times, zero twice
 - (D) negative twice, zero once

173. In a series R-L-C circuit, the "Q-factor" is given by

- (A) $Q = \frac{1}{R} \sqrt{\frac{L}{C}}$
- (B) $Q = R \sqrt{\frac{L}{C}}$
- (C) $Q = \frac{1}{R} \sqrt{\frac{C}{L}}$
- (D) $Q = R \sqrt{\frac{C}{L}}$

174. In an ac circuit, $V = (200 + j40)$ V and $I = (30 - j10)$ A. The active and reactive power of the circuit are respectively

- (A) 6400 W, 800 VAR capacitive
- (B) 6400 W, 800 VAR inductive
- (C) 5600 W, 3200 VAR capacitive
- (D) 5600 W, 3200 VAR inductive

175. Application of Norton's theorem in a circuit results in

- (A) a current source and an impedance in parallel
- (B) a voltage source and an impedance in series
- (C) an ideal voltage source
- (D) an ideal current source

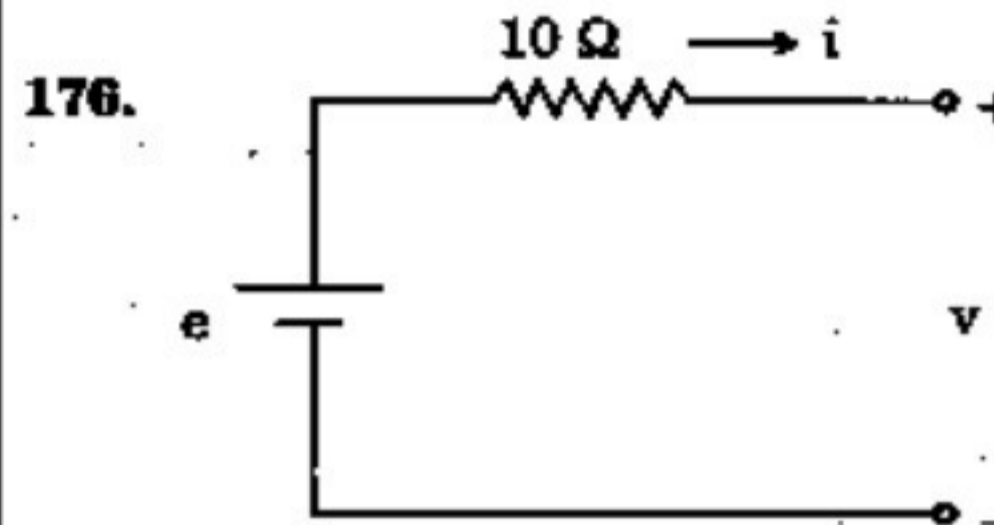

The voltage (v) vs. current (i) curve of the circuit is shown below :

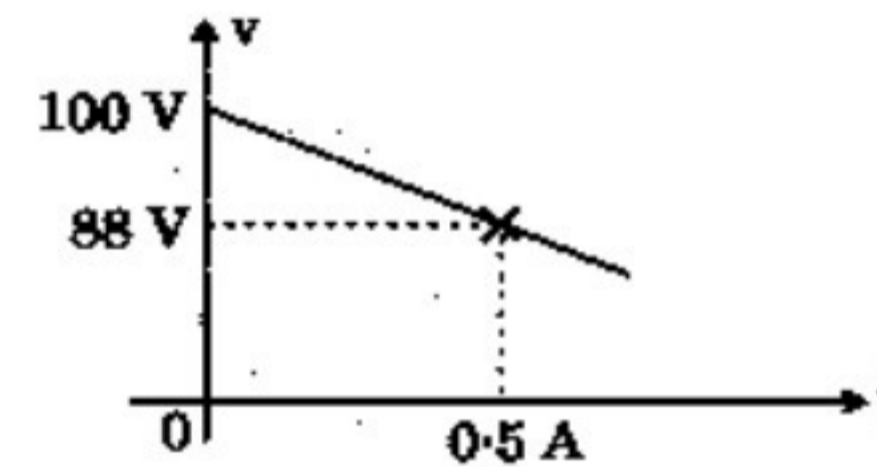

Internal resistance of the source e is

- (A) 24 Ω
- (B) 4 Ω
- (C) 10 Ω
- (D) 14 Ω

177. Value of the load impedance \bar{Z}_L for which the load consumes maximum power is

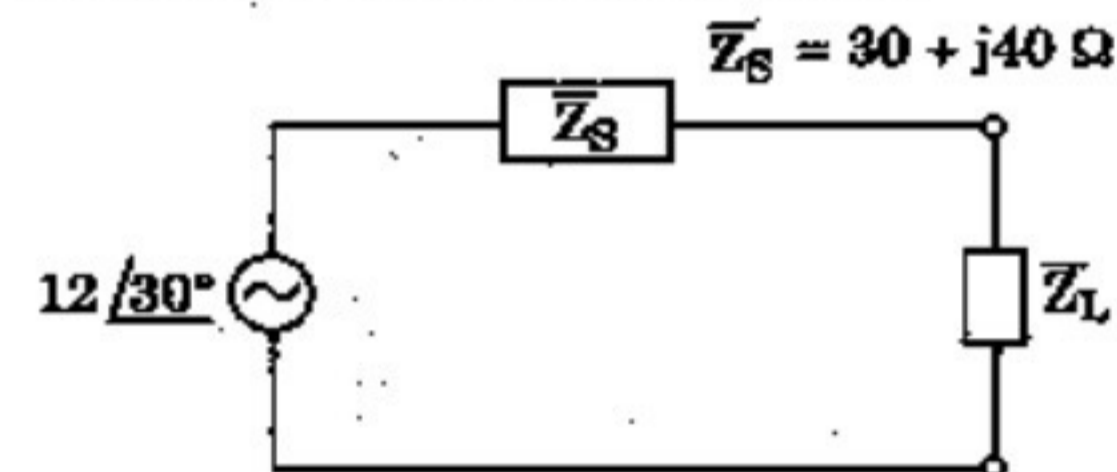

- (A) 50 Ω at a power factor of 0.6 lead
- (B) 50 Ω at a power factor of 0.6 lag
- (C) 30 Ω at a power factor of unity
- (D) None of the above

178. The speed-torque characteristic of a dc series motor operating from a constant voltage supply is

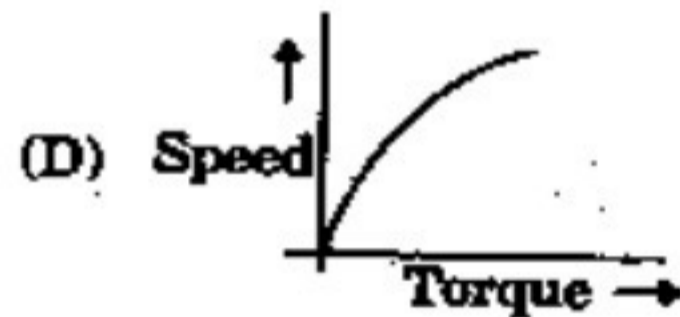
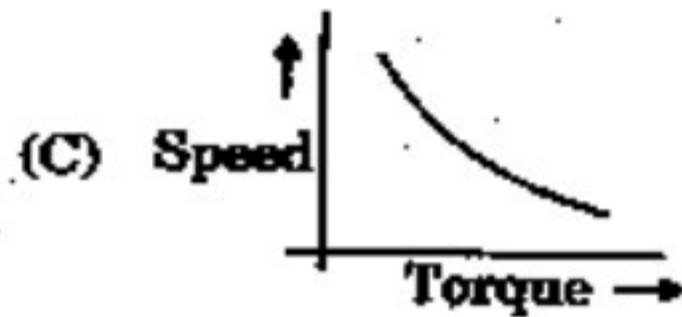
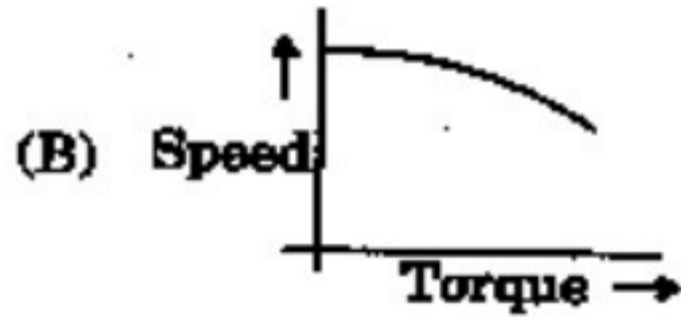
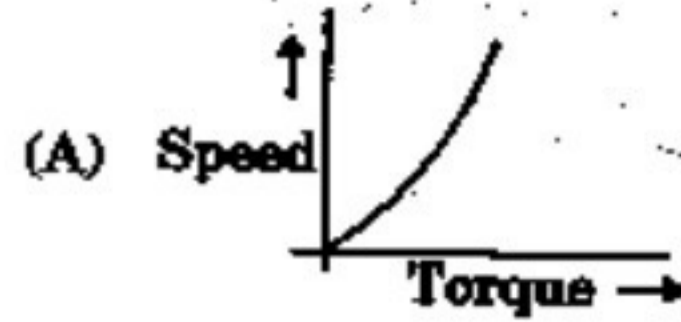

179. Match List I (Machine) with List II (Graph) and select the appropriate response.

<i>List I</i>	<i>List II</i>
a. DC Motor	(i) Circle diagram
b. DC Generator	(ii) V-curve
c. Alternator	(iii) Open circuit characteristics
d. Induction motor	(iii) Speed-Torque characteristics

- (A) a-(iv), b-(iii), c-(i), d-(ii)
 (B) a-(iii), b-(iv), c-(ii), d-(i)
 (C) a-(iv), b-(iii), c-(ii), d-(i)
 (D) a-(iii), b-(iv), c-(i), d-(ii)

180. Three equal impedances are first connected in delta across a 3-phase balanced supply. If the same impedances are connected in star across the same supply

- (A) phase currents will be $\frac{1}{3}$ of the previous value.
 (B) line currents will be $\frac{1}{3}$ of the previous value.
 (C) power consumed will be $\frac{1}{3}$ of the previous value.
 (D) power consumed will be 3 times the previous value.

181. The average value of the voltage wave $v = 110 + 175 \sin(314t - 25^\circ)$ volts is

- (A) 110 V
 (B) 175 V
 (C) 165.57 V
 (D) 206.7 V

182. A current from an ac source bifurcates into two branches A and B in parallel. Branch A is an inductor with $30 \mu\text{H}$ inductance and 1Ω resistance. Branch B is another inductor with inductance L and 1.5Ω resistance. For the ratio of currents in the branches to be independent of supply frequency, value of L should be

- (A) $30.5 \mu\text{H}$ (B) $20 \mu\text{H}$
 (C) $45 \mu\text{H}$ (D) $29.5 \mu\text{H}$

183. A universal motor is one which

- (A) can run on any value of supply voltage
 (B) has infinitely varying speed
 (C) can operate on ac as well as dc voltage
 (D) can work as single-phase or three-phase motor

184. If the centrifugal switch of a single-phase resistance split induction motor does not open after starting of motor, the motor
- (A) will run above normal speed
 - (B) will run below normal speed
 - (C) will draw very small current
 - (D) will draw high current and get over-heated
185. Alternators are usually designed to generate which type of a.c. voltage ?
- (A) With fixed frequency
 - (B) With variable frequency
 - (C) Fixed current
 - (D) Fixed power factor
186. Three inductors each of 60 mH are connected in delta. The value of inductance of each arm of the equivalent star connection is
- (A) 10 mH
 - (B) 15 mH
 - (C) 20 mH
 - (D) 30 mH
187. The magnetic field energy in an inductor changes from maximum value to minimum value in 5 msec when connected to an ac source. The frequency of the source in Hz is
- (A) 500
 - (B) 200
 - (C) 50
 - (D) 20
188. A voltage source having an open-circuit voltage of 150 V and internal resistance of 75 Ω , is equivalent to a current source of
- (A) 2 A in series with 75 Ω
 - (B) 2 A in parallel with 37.5 Ω
 - (C) 2 A in parallel with 75 Ω
 - (D) 1 A in parallel with 150 Ω
189. A 300 kW alternator is driven by a prime mover of speed regulation 4% while the prime mover of another 200 kW alternator has a speed regulation of 3%. When operating in parallel, the total load they can take without any of them being overloaded is
- (A) 500 kW
 - (B) 567 kW
 - (C) 425 kW
 - (D) 257 kW
190. The commutator in a d.c. machine acts as
- (A) a mechanical inverter
 - (B) a mechanical rectifier
 - (C) current controller
 - (D) either (A) or (B)
191. The purpose of using dummy coil in d.c. machines is to
- (A) eliminate harmonics developed in the machine
 - (B) eliminate armature reaction
 - (C) bring mechanical balance of the armature
 - (D) bring mechanical balance of the body of the motor

192. An inductor with a ferromagnetic core is supplied from a sinusoidal voltage source with frequency 'f'. The current drawn by the inductor will be

- (A) sinusoidal with frequency 'f'.
- (B) sinusoidal with frequency '2f'.
- (C) a sawtooth wave.
- (D) non-sinusoidal with frequency 'f'

193. For a 6-pole d.c. machine with wave wound armature, the number of brushes required is

- (A) 2
- (B) 4
- (C) 6
- (D) 12

194. Function of interpoles in a d.c. machine is to

- (A) reduce field winding heating.
- (B) improve commutation.
- (C) compensate for air-gap variation.
- (D) reduce losses

195. The commutator segments of d.c. machine are made of

- (A) tungsten
- (B) hard-drawn copper
- (C) soft copper
- (D) electrolytic copper

196. Which one of the following is a speed control method of three-phase squirrel cage induction motor?

- (A) Plugging method
- (B) Star-delta switch method
- (C) Pole-changing method
- (D) Centrifugal clutch method

197. In the circuit as shown, voltage measured between A, B is found to be 70 V. Value of M is

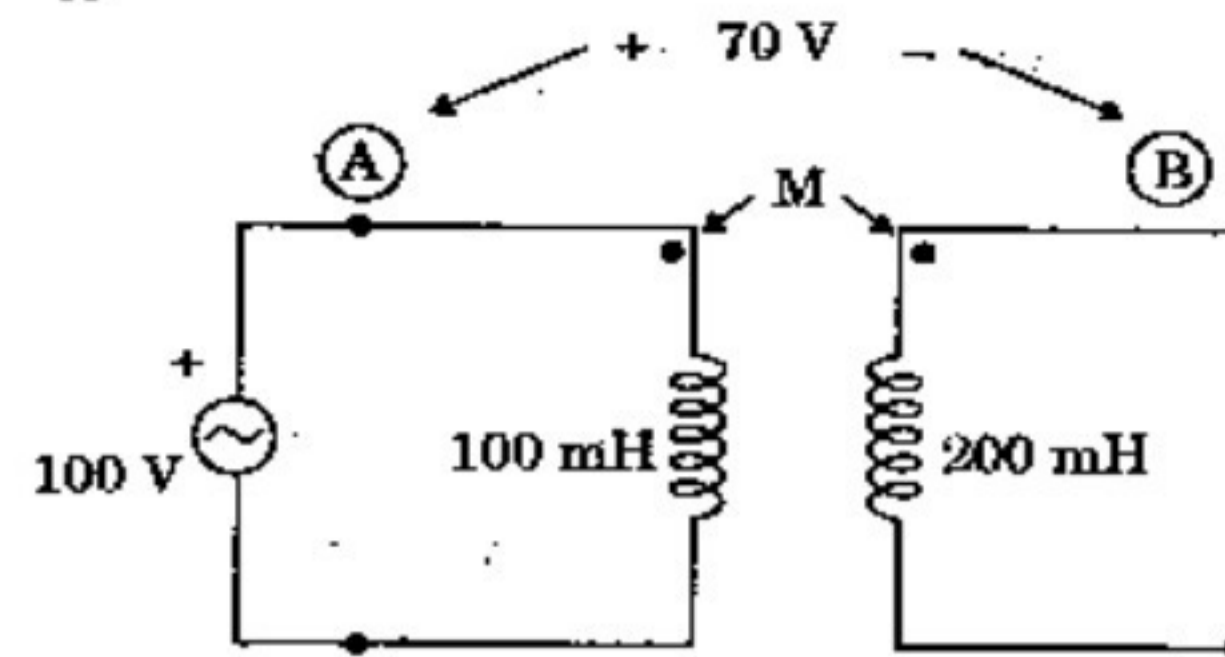

- (A) 30 mH
- (B) 100 mH
- (C) 200 mH
- (D) 70 mH

198. Two coupled coils, connected in series, have an equivalent inductance of 16 mH or 8 mH depending on the connection. The mutual inductance between the coils is

- (A) 12 mH
- (B) $8\sqrt{2}$ mH
- (C) 4 mH
- (D) 2 mH

199. Tesla is the unit of

- (A) electric flux density
- (B) magnetic field intensity
- (C) electric field intensity
- (D) magnetic flux density

200. Which one of the following is a valid value of coefficient of coupling between two inductors?

- (A) 1.414
- (B) 0.9
- (C) 1.732
- (D) 17.32

TEST (iii)
PART - C : GENERAL ENGINEERING
(MECHANICAL)

101. In wheel and differential axle, the velocity ratio is given by
- (A) $\frac{d_1 - d_2}{2D}$ (B) $\frac{d_1 - d_2}{4D}$
(C) $\frac{2D}{d_1 - d_2}$ (D) $\frac{3D}{d_1 - d_2}$
102. Acme threads are generally used in
- (A) railway carriage couplings
(B) spindles of bench vices
(C) screw cutting lathes
(D) feed mechanism of machine tools
103. In a Hartnell governor, 800 N force is exerted on the sleeve at minimum radius and 1200 N force is exerted at maximum radius. If sleeve lift is 20 mm, the value of spring stiffness (s) is
- (A) 10 N/mm (B) 20 N/mm
(C) 15 N/mm (D) 18 N/mm
104. The maximum and minimum speeds of a flywheel during a cycle are N_1 and N_2 r.p.m. respectively. The coefficient of steadiness of the flywheel is
- (A) $\frac{N_1 - N_2}{2(N_1 + N_2)}$
(B) $\frac{N_1 + N_2}{2(N_1 - N_2)}$
(C) $\frac{2(N_1 + N_2)}{N_1 - N_2}$
(D) $\frac{N_1 + N_2}{N_1 - N_2}$
105. The angle of Vee belts is
- (A) 30° (B) 35°
(C) 40° (D) 45°
106. Which of the following statements is *not* true for couplings ?
- (A) Couplings are meant for transmitting torque
(B) Couplings keep the mating shafts in alignment
(C) Couplings are used in shafts
(D) Couplings connect parallel shafts
107. The sum of the tensions when the belt is running on the pulley is
- (A) less than the initial tension
(B) more than the initial tension
(C) more than twice the initial tension
(D) half the initial tension
108. A steel bar is fixed at both ends. If the bar is heated, it will develop
- (A) Compressive stress
(B) Tensile stress
(C) Bending stress
(D) None of the above.
109. For a screw, the angle of helix (α) is related to the lead (L) and mean screw thread diameter (d) as
- (A) $\tan \alpha = \frac{L}{d}$ (B) $\tan \alpha = \frac{d}{L}$
(C) $\tan \alpha = \frac{L}{\pi d}$ (D) $\tan \alpha = \frac{\pi d}{L}$
110. A slider crank chain is a four bar linkage consisting of
- (A) one sliding pair and two turning pairs
(B) one sliding pair and three turning pairs
(C) two sliding pairs and two rotating pairs
(D) two sliding pairs and two turning pairs

111. If two shafts of the same length, one of which is hollow, transmit equal torques and have equal maximum stress, then they should have equal
- (A) polar moment of inertia
(B) polar modulus of section
(C) diameter
(D) angle of twist
112. In case of cantilever, irrespective of the type of loading, the maximum bending moment and maximum shear force occur at
- (A) fixed end (B) free end
(C) middle (D) any point
113. Ratio of moment of inertia of a circle and that of a square having same area about their centroidal axis is
- (A) $\frac{3}{\pi}$ (B) $\frac{3}{2\pi}$
(C) $\frac{4}{\pi}$ (D) $\frac{5}{9\pi}$
114. A circular shaft can transmit a torque of 13 kN-m. If the torque is reduced to 12 kN-m, then the maximum value of bending moment that can be applied to the shaft is
- (A) 1 kN-m (B) 3 kN-m
(C) 5 kN-m (D) 7 kN-m
115. *Assertion (A) :*
The preferred cross-section of a beam subjected to transverse loading is I section.
- Reason (R) :*
Section modulus of I section is low.
- (A) Both A and R are true and R is a correct explanation of A
(B) Both A and R are true but R is not a correct explanation of A
(C) A is true but R is false
(D) R is true but A is false
116. A point on a link connecting double slider crank chain traces a/an
- (A) Straight line path
(B) Circular path
(C) Parabolic path
(D) Elliptical path
117. The angular speed of a Wall's governor, when its height is 20 cm, will be equal to
- (A) 20 rad/sec
(B) 10 rad/sec
(C) 6 rad/sec
(D) 7 rad/sec
118. The efficiency in case of worm gear drives is generally in the range of
- (A) 10 – 25 percent
(B) 40 – 60 percent
(C) 50 – 70 percent
(D) 70 – 85 percent
119. In a kinematic chain, the minimum number of kinematic pairs required is
- (A) one (B) two
(C) three (D) four
120. For a key to be equally strong in shearing and crushing, the width of the key, assuming that the allowable crushing stress is twice the allowable shear stress, should be
- (A) 2.5 times its thickness
(B) 2 times its thickness
(C) 1.5 times its thickness
(D) equal to its thickness
121. Tension in the tight side of a belt drive is 100 N and that in the slack side 60 N. If the belt breadth is 10 cm and thickness 4 cm, what is the maximum stress induced in the belt?
- (A) 2.5 N/cm² (B) 1.5 N/cm²
(C) 4 N/cm² (D) 2 N/cm²

122. A uniform simply supported beam of span (l) carries a point load (W) at the centre. The downward deflection at the centre will be
(A) $Wl^2/8 EI$ (B) $Wl^3/8 EI$
(C) $5 Wl^3/384 EI$ (D) $Wl^3/48 EI$

123. The power transmitted by a circular shaft rotating at N rpm under action of Torque T is
(A) $2\pi NT/750$ (B) $2\pi NT/60$
(C) $2\pi NT/450$ (D) $2\pi NT/4500$

124. A cylinder is said to be thin if the thickness to diameter ratio is less than
(A) $1/5$ (B) $1/10$
(C) $1/15$ (D) $1/20$

125. The bending moment on a section is maximum where shearing force is
(A) Minimum (B) Maximum
(C) Zero (D) Changing sign

126. Strut is defined as a
(A) Member of a structure which carries a tensile load
(B) Member of a structure which carries an axial compressive load
(C) Vertical member of a structure which carries a tensile load
(D) Vertical member of a structure which carries no load

127. The expression $\int_1^2 p dv$ gives the measure of work done during
(A) steady flow reversible process
(B) non-flow reversible process
(C) open system and any process
(D) any system and any process

128. The value of Poisson's ratio is always less than
(A) 1 (B) 0.2
(C) 0.4 (D) 0.5

129. The spindle of a machine tool is subjected to the following type of load :
(A) Torsional load
(B) Bending load
(C) Axial compressive load
(D) Axial tensile load

130. The cross-section of a member is subjected to a uniform shear stress τ . The strain energy stored per unit volume is equal to (G = modulus of rigidity)
(A) $\frac{2\tau^2}{G}$ (B) $\frac{\tau^2}{G}$
(C) $\frac{\tau^2}{2G}$ (D) $\frac{2G}{\tau^2}$

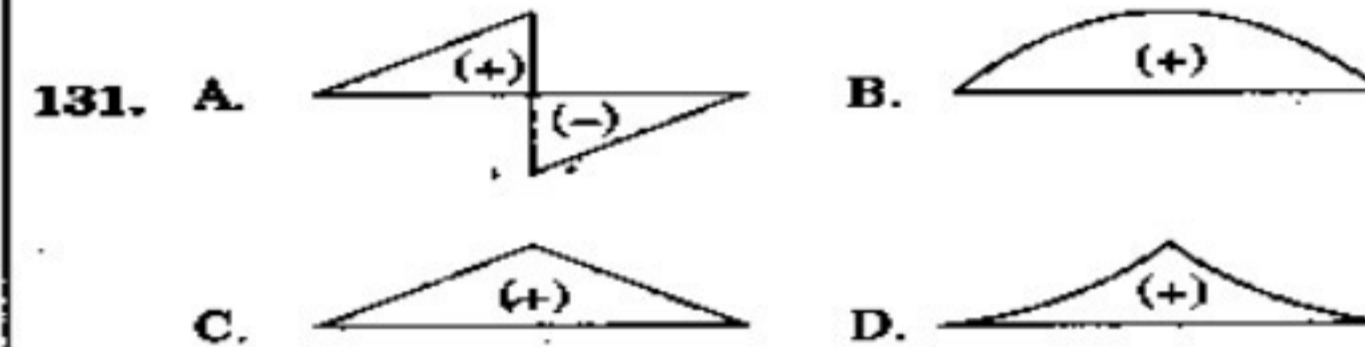

Figures A, B, C and D are bending moment distributions of a simply supported beam for some particular shear stress distribution. Which figure is the correct bending moment diagram corresponding to the shear stress distribution given below :

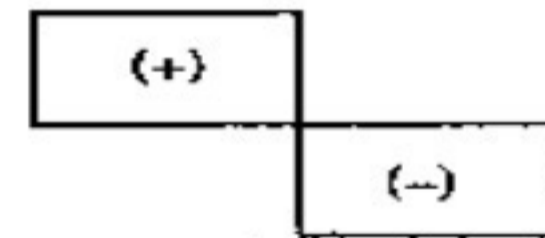

(A) A is correct bending moment distribution
(B) B is correct bending moment distribution
(C) C is correct bending moment distribution
(D) D is correct bending moment distribution

132. Which property is an intensive property of the system ?
 (A) Specific enthalpy
 (B) Volume
 (C) Kinetic energy
 (D) Entropy
133. One of the extensive properties of a thermodynamic system amongst the following is
 (A) pressure (B) volume
 (C) temperature (D) density
134. A heat engine is supplied with 278 kW of heat at a constant fixed temperature of 283°C and the heat rejection takes place at 5°C. The engine is reversible if the heat rejected, in kW, is
 (A) 139 (B) 208
 (C) 35 (D) 70
135. Function of carburettor is to supply
 (A) air and petrol mixture
 (B) air and diesel mixture
 (C) only petrol
 (D) petrol and diesel mixture
136. In a boiler, the feed check valve is used to
 (A) control the feed water flow rate
 (B) check the water level in drum
 (C) ensure unidirectional feed flow to drum
 (D) check quality of feed water
137. When wet steam flows through a throttle valve
 (A) its temperature increases and dryness improves
 (B) its temperature increases but dryness decreases
 (C) its temperature decreases but dryness improves
 (D) its temperature and dryness decrease
138. What approximate percentage of heat of combustion is lost to the jacket cooling water ?
 (A) 5% (B) 10%
 (C) 15% (D) 25%
139. If two liquids at different temperatures are mixed, then the final temperature of the mixture of liquids can be obtained by using
 (A) Zeroth law of thermodynamics
 (B) First law of thermodynamics
 (C) Second law of thermodynamics
 (D) Third law of thermodynamics
140. For an irreversible thermodynamic cycle
 (A) $\int \frac{dQ}{T} > 0$ (B) $\int \frac{dQ}{T} < 0$
 (C) $\int \frac{dQ}{T} \geq 0$ (D) $\int \frac{dQ}{T} \leq 0$
141. The enthalpy of evaporation of water
 (A) decreases with increase in pressure
 (B) decreases with decrease in pressure
 (C) increases with increase in pressure
 (D) remains unaffected by change in pressure
142. In a throttling process, the following thermodynamic property remains constant :
 (A) Enthalpy (B) Entropy
 (C) Specific heat (D) Energy
143. Heat supplied to a system equals the work done in case of non-flow process carried out
 (A) isochorically (B) isobarically
 (C) isothermally (D) adiabatically
144. Neglecting changes in potential and kinetic energies, the shaft work during a steady flow process is given by
 (A) $\int p dv$ (B) $\int v dp$
 (C) $\int T ds$ (D) $\int s dT$

145. In diesel engine, the suction contains
(A) air only
(B) fuel only
(C) mixture of air and fuel
(D) air or fuel
146. The fluid drawn in during suction in petrol engine contains
(A) fuel only
(B) fuel or air
(C) air only
(D) mixture of air and fuel
147. Spark ignition engine is
(A) petrol engine (B) diesel engine
(C) steam engine (D) C.I. engine
148. The working fluid for a diesel engine during the suction stroke is
(A) fuel-air mixture
(B) fresh air
(C) products of combustion
(D) None of the above
149. For a convergent nozzle, if the exit pressure is less than critical pressure, the mass rate of flow will be
(A) increasing (B) decreasing
(C) zero (D) constant
150. In impulse turbine, pressure on the two sides of the moving blades
(A) increases
(B) decreases
(C) remains same
(D) may decrease or remain constant
151. Brayton cycle is a reversed
(A) Carnot cycle (B) Rankine cycle
(C) Joule cycle (D) Dual cycle
152. In internal combustion engine terminology, MPFI stands for
(A) Multi Pressure Fuel Injection
(B) Multi Point Fired Ignition
(C) Multi Point Fuel Injection
(D) Multi Pressure Fired Ignition
153. For complete burning of 1 kg of carbon, the air required will be about
(A) 2.67 kg (B) 12.7 kg
(C) 11.6 kg (D) 14.5 kg
154. 1 ton of refrigeration is equivalent to
(A) 1 kW (B) 2.5 kW
(C) 3.5 kW (D) 5 kW
155. Knocking tendency in an SI engine reduces with increasing
(A) Compression ratio
(B) Wall temperature
(C) Supercharging
(D) Engine speed
156. Cetane number of a fuel is a measure of its
(A) viscosity
(B) volatility
(C) ignition quality
(D) API specific gravity
157. Critical pressure for steam is
(A) 252 bar (B) 225 bar
(C) 184 bar (D) 163 bar
158. Maximum steam pressure (in bar) in a locomotive boiler is limited to
(A) 5 (B) 10
(C) 18 (D) 25
159. Compounding of steam turbine is done to
(A) balance the rotor
(B) reduce the blade friction
(C) reduce the rotor speed
(D) connect the shaft of one turbine to that of another

160. Francis Turbine is best suited for
- (A) all types of heads
 - (B) medium head application from 24 to 180 m
 - (C) low head installations up to 30 m
 - (D) high head installations above 180 m

161. Head developed by a centrifugal pump depends on
- (A) Impeller diameter
 - (B) Speed
 - (C) Type of casing
 - (D) (A) and (B) above

162. The vertical distance of the center of pressure below the c.g. of the inclined plane area (submerged in liquid) is

- (A) $\frac{I_{cg} \cdot \sin^2 \theta}{A\bar{x}}$
- (B) $\frac{I_{cg} \cdot \cos^2 \theta}{A\bar{x}}$
- (C) $\frac{I_{cg} \cdot A \sin^2 \theta}{\bar{x}}$
- (D) $\frac{I_{cg} \cdot A \cos^2 \theta}{\bar{x}}$

where θ = inclination of plane area
 \bar{x} = distance of c.g. of plane area from free liquid surface

163. For a nozzle to convert subsonic flow into a supersonic flow, it must be
- (A) convergent type
 - (B) divergent type
 - (C) convergent-divergent type
 - (D) of uniform cross-sectional area

164. For the same maximum pressure and peak temperature, which cycle will be most efficient?
- (A) Diesel
 - (B) Dual combustion
 - (C) Otto
 - (D) None of the above

165. An ideal fluid
- (A) has no viscosity
 - (B) satisfies the relation $p v = RT$
 - (C) obeys Newton's Law of Viscosity
 - (D) is both incompressible and non-viscous

166. For small discharge at high pressure following pump is preferred:
- (A) Mixed flow
 - (B) Reciprocating
 - (C) Axial flow
 - (D) Centrifugal

167. In a Reaction Turbine
- (A) flow can be regulated without loss
 - (B) water may be allowed to enter a part or whole of wheel circumference
 - (C) the outlet must be above the tail race
 - (D) there is only partial conversion of available head to velocity head before entry to runner

168. Impulse Turbine is generally fitted
- (A) little above the tail race
 - (B) at the level of the tail race
 - (C) slightly below the tail race
 - (D) about 2.5 meters below the tail race

169. In general, the vanes of a centrifugal pump are
- (A) curved forward
 - (B) curved backward
 - (C) radial
 - (D) twisted

170. A rectangular tank of square cross-section ($2\text{ m} \times 2\text{ m}$) and height 4 m is completely filled up with a liquid. The ratio of total hydrostatic force on any vertical wall to its bottom is
- (A) 2.0 (B) 1.5
(C) 1.0 (D) 0.5
171. Air vessel is used in a reciprocating pump to obtain
- (A) reduction of suction head
(B) rise in delivery head
(C) continuous supply of water at uniform rate
(D) increase in supply of water
172. Shear stress in a turbulent flow is due to
- (A) viscous property of the fluid
(B) fluid density
(C) fluctuation of velocity in the direction of flow
(D) fluctuation of velocity in the direction of flow as well as transverse to it
173. The discharge through a single acting reciprocating pump is $[N \rightarrow \text{rpm}]$
- (A) $Q = ALN$
(B) $Q = ALN/60$
(C) $Q = 2 ALN/60$
(D) $Q = 2 ALN$
174. For viscous flow between two parallel plates, the pressure drop per unit length is equal to
- (A) $12 \mu \bar{U} L / \rho g D^2$
(B) $12 \mu \bar{U} / D^2$
(C) $12 \mu \bar{U} L / D^2$
(D) $32 \mu \bar{U} L / D^2$
175. A liquid moving with constant angular momentum has tangential velocity of 1.2 m/s , 3 m from axis of rotation. The tangential velocity at 1.5 m from axis of rotation, in m/s , is
- (A) 0.6 (B) 3.75
(C) 5.4 (D) 6.0
176. With the same cross-sectional area and placed in the turbulent flow, the largest drag will be experienced by
- (A) a sphere
(B) a streamlined body
(C) a circular disc held normal to the flow direction
(D) a circular disc held parallel to the flow direction
177. A streamlined body is such that
- (A) it produces no drag for flow around it
(B) it is symmetrical about the axis along the free stream
(C) separation of flow is avoided along its surface
(D) the shape of the body coincides with the stream surface
178. Pascal second is the unit of
- (A) pressure
(B) kinematic viscosity
(C) dynamic viscosity
(D) surface tension
179. The shear stress in a turbulent pipe flow
- (A) varies parabolically with radius
(B) is constant over the pipe radius
(C) varies according to the $\frac{1}{7}$ th power law
(D) is zero at the centre and increases linearly to the wall

180. In order to get the uniform thickness of the plate by rolling process, one provides

- (A) Camber on the rolls
- (B) Offset on the rolls
- (C) Hardening of the rolls
- (D) Antifriction bearing

181. The most important requisite of a cutting tool material is

- (A) carbon percentage
- (B) percentage of alloying element
- (C) red (hot) hardness
- (D) easy fabrication

182. The soldering process is carried out in the temperature range

- (A) 15 – 60°C (B) 70 – 150°C
- (C) 180 – 250°C (D) 300 – 500°C

183. In electrical resistance welding, both heat and pressure are used to effect coalescence. The pressure necessary to effect the weld varies from

- (A) 50 – 100 kgf/cm²
- (B) 100 – 200 kgf/cm²
- (C) 250 – 500 kgf/cm²
- (D) 500 – 850 kgf/cm²

184. The angle between the face and the flank of the single point cutting tool is known as

- (A) rake angle
- (B) clearance angle
- (C) lip angle
- (D) side angle

185. The unit discharge, Q_u and unit speed, N_u curve for a turbine is shown in figure. Curve B is for

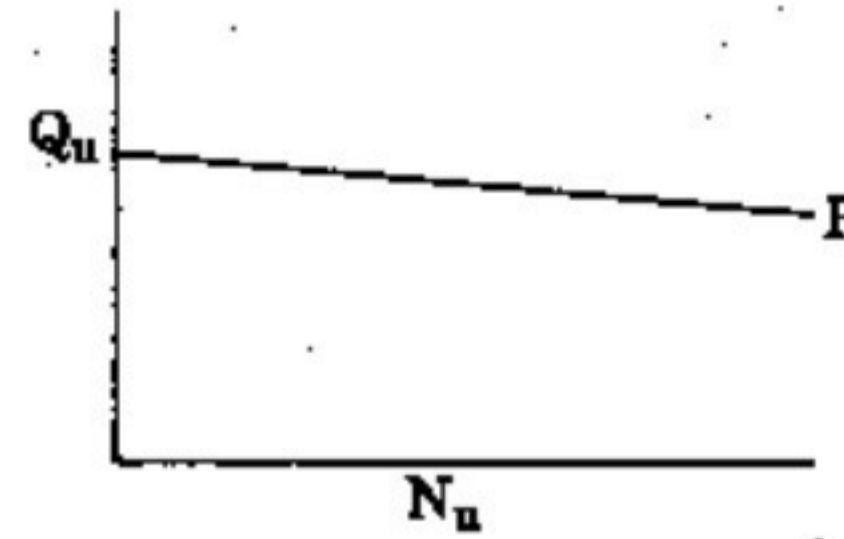

- (A) Francis turbine
- (B) Kaplan turbine
- (C) Pelton turbine
- (D) Propeller turbine

186. Permeability is poor for

- (A) Fine grains (B) Medium grains
- (C) Coarse grains (D) Rounded grains

187. Dies for wire drawing are made of

- (A) Cast Steel
- (B) Cast Iron
- (C) Carbides
- (D) Wrought Iron

188. In Thermit welding, Aluminium and Iron oxide are mixed in the proportion of

- (A) 1 : 3 (B) 1 : 2
- (C) 1 : 1 (D) 2 : 1

189. Metal patterns are used for

- (A) small castings
- (B) large castings
- (C) precise and intricate castings
- (D) large scale production of castings

- 190.** Tool signature comprises of how many elements ?
 (A) 5 (B) 7
 (C) 9 (D) 11
- 191.** A half nut is
 (A) nut manufactured in parts
 (B) nut with half the standard pitch
 (C) a double start nut for a quick shaft
 (D) mechanism that locks the lathe carriage to the lead screw for thread cutting
- 192.** Automobile gears are generally manufactured by
 (A) Hobbing (B) Stamping
 (C) Extrusion (D) Rolling
- 193.** Spot welding is most suitable for joining parts having thickness up to
 (A) 50 mm (B) 30 mm
 (C) 20 mm (D) 10 mm
- 194.** Thermit welding differs from other methods of welding in that
 (A) it does not use heat
 (B) it is less time consuming
 (C) it does not require electrodes
 (D) it employs exothermic chemical reaction for developing high temperature
- 195.** The binder in case of synthetic sand used for moulding is
 (A) Clay
 (B) Molasses
 (C) Water
 (D) Bentonite and water
- 196.** The commonly used flux for Brazing is
 (A) Slag
 (B) Borax
 (C) Lead
 (D) Calcium chloride
- 197.** Blanking and piercing operations can be performed simultaneously in
 (A) Simple die
 (B) Compound die
 (C) Progressive die
 (D) Combination die
- 198.** If electric current is passed through the metals to be joined and heated to the plastic state and weld is completed by the application of pressure, the welding is known as
 (A) Forge weld
 (B) Electric arc welding
 (C) Resistance welding
 (D) Thermit welding with pressure
- 199.** In case of shaper, for finish machining, the practice is to use
 (A) maximum feeds at high speeds
 (B) maximum feeds at slow speeds
 (C) minimum feeds at slow speeds
 (D) minimum feeds at high speeds
- 200.** In which milling operation, is the surface finish better ?
 (A) Climb
 (B) Down
 (C) Conventional
 (D) Face

MANNER IN WHICH ANSWERS ARE TO BE GIVEN

उत्तर देने की विधि

Directions : Each question or incomplete statement is followed by four alternative suggested answers or completions. In each case, you are required to select the one that correctly answers the question or completes the statement and blacken appropriate oval A, B, C or D by Black/Blue Ball-point pen against the question concerned in the Answer-Sheet.

The following example illustrates the manner in which the questions are required to be answered.

Example :

Question No. 'Q' —

Out of the four words given below, three are alike in some way and one is different. Find the

odd one out.



Explanation : In the above example, the correct answer is 'D' and this answer has been indicated by blackening the oval by Black/Blue Ball-point pen in column 'D' against Question No. 'Q' in the manner indicated below :

Question No. 'Q'



There is only one correct answer to each question. You should blacken the oval of the appropriate column, viz., A, B, C or D. If you blacken more than one oval against any one question, the answer will be treated as wrong. If you wish to cancel any answer, you should completely erase that black mark in the oval in the Answer-Sheet, and then blacken the oval of revised response.

You are NOT required to mark your answers in this Booklet. All answers must be indicated in the Answer-Sheet only.

निर्देश : प्रत्येक प्रश्न अथवा प्रत्येक अधूरे कथन के बाद चार उत्तर अथवा पूरे कथन सुझाए गए हैं। प्रत्येक दशा में आपको किसी एक को चुनना है जो प्रश्न का सही उत्तर दे अथवा कथन को पूरा करे और आपको उत्तर-पत्रिका में उपयुक्त अक्षरकार खाने A, B, C या D को काला/नीला बॉल-पॉइंट पेन से काला करना है।

नीचे दिए गए उदाहरण से स्पष्ट हो जाएगा कि उत्तर किस प्रकार दिए जाने हैं।

उदाहरण :

प्रश्न सं. 'क्यू' —

नीचे दिए हुए चार शब्दों में तीन कुछ मिलते-जुलते हैं, तथा एक कुछ अलग किस्म का है। वह अलग किस्म का शब्द बताएँ :

- (A) लड़की
- (B) लड़का
- (C) महिला
- (D) कुर्सी

स्पष्टीकरण : ऊपर के उदाहरण में सही उत्तर 'कुर्सी' है और यह उत्तर 'D' में सुझाया गया है। अतः प्रश्न सं. 'क्यू' के सामने कॉलम 'D' के अक्षरकार खाने को काला/नीला बॉल-पॉइंट पेन से पूर्णतया काला करके उत्तर नीचे बताई विधि के अनुसार दिया जाना है :

प्रश्न सं. 'क्यू'



प्रत्येक प्रश्न का केवल एक ही सही उत्तर है। आपको समुचित कॉलम अर्थात् A, B, C या D के अक्षरकार खाने को काला करना है। यदि आप किसी प्रश्न के सामने एक से अधिक अक्षरकार खाने को भरेंगे , तो आपका उत्तर गलत माना जाएगा। यदि आप किसी उत्तर को रद्द करना चाहते हैं, तो अगर उत्तर-पत्रिका के उस अक्षरकार खाने से काले निशान को पूरी तरह से मिटा दें और अब बदले हुए उत्तर के लिए अक्षरकार खाने को काला कर दें।

इस पुस्तिका के अन्दर आपको उत्तर अंकित नहीं करने हैं। सभी उत्तर केवल उत्तर-पत्रिका में ही दें।

SEAL