

Test Booklet Number

00171

Subject Code : 1601

**MATHEMATICS AND
SCIENCE**

Roll Number

Time : 2 Hours]

[Maximum Marks : 300

INSTRUCTIONS TO CANDIDATES

Read the following instructions carefully before you answer the questions given in this Test Booklet :

1. Answers to questions in this Test Booklet are to be given on an **OMR Answer Sheet** provided to the candidate **separately**.
2. Candidate must fill up Name, Category, Test Booklet Number, Subject Code and Roll Number in the Answer Sheet carefully as per instructions given.
3. This Test Booklet consists of 75 questions. All questions are compulsory and carry equal marks.
4. Each question in this Test Booklet has four possible alternative answers namely, (A), (B), (C) and (D), one of which is correct. Candidate should choose the correct answer against each question out of four alternative answers.
5. Candidate is instructed to answer the questions by **darkening** (●) with **Ballpoint Pen** only in the circle bearing the correct answer.
6. Candidate should not attempt more than one answer in each question. More than one attempt in any form against a question shall be treated as incorrect.
7. Marking of answer other than darkening shall be cancelled and darkening should remain within the circle otherwise computer shall not accept during evaluation of Answer Sheet.
8. Rough work must not be done on the Answer Sheet. Use the blank space given in the Test Booklet for rough work.
9. Candidate is to hand over the Answer Sheet to the Invigilator before leaving the Examination Hall.
10. **NEGATIVE MARKING** : Each question carries 4 (four) marks for correct response. For each incorrect response, 1 (one) mark will be deducted from the total score. More than one answer indicated against a question will be deemed as incorrect response and will be negatively marked.

SEAL

SPACE FOR ROUGH WORK

Roll Number	Subject Code: 1601 MATHEMATICS AND SCIENCE	Test Booklet Number 00171
-------------	--	-------------------------------------

Maximum Marks - 300 | Time - 3 Hours

INSTRUCTIONS TO CANDIDATES

Read the following instructions carefully before you answer the questions given in this Test Booklet :

1. Answers to questions in this Test Booklet are to be given on an OMR Answer Sheet provided to the candidate separately.
2. Candidates must fill up Name, Category, Test Booklet Number, Subject Code and Roll Number in the Answer Sheet carefully as per instructions given.
3. This Test Booklet consists of 75 questions. All questions are compulsory and carry equal marks.
4. Each question in this Test Booklet has four possible alternative answers namely, (A), (B), (C) and (D), one of which is correct. Candidates should choose the correct answer against each question out of four alternative answers.
5. Candidate is instructed to answer the questions by darkening (●) with Ballpoint Pen only in the circle bearing the correct answer.
6. Candidate should not attempt more than one answer in each question. More than one attempt in any form against a question shall be treated as incorrect.
7. Marking of answer other than darkening shall be cancelled and darkening should remain within the circle otherwise answer shall not accept during evaluation of Answer Sheet.
8. Rough work must not be done on the Answer Sheet. Use the blank space given in the Test Booklet for rough work.
9. Candidate is to hand over the Answer Sheet to the Investigator before leaving the Examination Hall.
10. **NEGATIVE MARKING :** Each question carries 4 (four) marks for correct response. For each incorrect response, 1 (one) mark will be deducted from the total score. More than one answer indicated against a question will be deemed as incorrect response and will be negatively marked.

MATHEMATICS

1. The rationalising factor of $\sqrt[3]{a^3b^4c^2}$ is

- (A) $\sqrt{a^4b^3c^5}$ (B) $\sqrt[4]{a^4c^5b^3}$
 (C) $\sqrt[7]{b^3c^5a^4}$ (D) $\sqrt[3]{c^5a^4b^3}$

2. The equivalent rational form of $17.\bar{6}$ is

- (A) $\frac{88}{5}$ (B) $\frac{53}{3}$
 (C) $\frac{444}{25}$ (D) $\frac{169}{9}$

3. The remainder when $a^4 - b^4$ is divided by $(a - b)$ is

- (A) $a^3 - b^3$
 (B) $a^2 + b^2$
 (C) 0
 (D) $(a^2 + b^2)(a + b)$

4. If $\left(3x + \frac{2}{x}\right) = 7$, then the value of

- $\left(9x^2 - \frac{4}{x^2}\right)$ is
 (A) 35
 (B) 49
 (C) 28
 (D) 36

5. If $x^2 - 1$ is a factor of $ax^4 + bx^3 + cx^2 + dx + e$, then which of the following option is true?

- (A) $a + b + e = c + d$
 (B) $a + b + c = d + e$
 (C) $a + b + d = c + e$
 (D) $a + c + e = b + d$

6. A, B, C and D are the points on a line. E is a point outside this line. Given that $AE = BE = AB = BC$ and $CE = CD$, then $m\angle DEA$ is

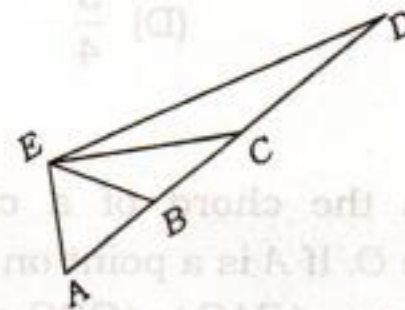

- (A) 90° (B) 105°
 (C) 120° (D) 150°

7. In the adjoining figure, RS is a diameter of circle. X is a point lying outside the circle. Then $\angle RXS$ is

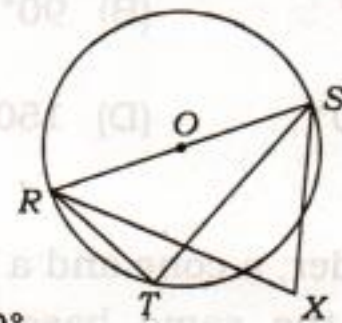

- (A) 90°
 (B) greater than 90°
 (C) less than 90°
 (D) Cannot be determined from the given data

8. The diagonals AC and BD of a parallelogram $ABCD$ intersect each other at O . PQ is a line through O which meets BC at P and AD at Q .

If area (quadrilateral $ABPQ$) = $k \times$ area (quadrilateral $ABCD$) then k equals

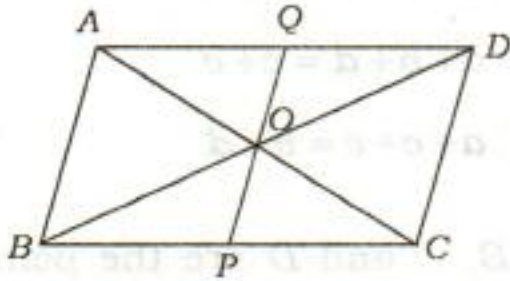

- (A) $\frac{1}{3}$ (B) $\frac{1}{2}$
 (C) $\frac{2}{3}$ (D) $\frac{3}{4}$

9. BC is the chord of a circle with centre O . If A is a point on major arc BC , then $\angle BAC + \angle OBC$ equals

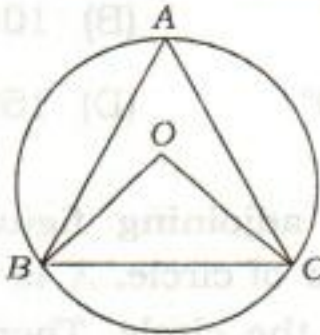

- (A) 60° (B) 90°
 (C) 120° (D) 150°

10. A cylinder, a cone and a hemisphere are of the same base and of the same height. The ratio of their volumes is

- (A) $1 : 2 : 3$ (B) $2 : 1 : 3$
 (C) $3 : 1 : 2$ (D) $3 : 2 : 1$

11. A real number

$$\frac{2^2 \times 3^2 \times 7^2}{2^5 \times 5^3 \times 3^2 \times 7}$$

will have

- (A) repeating decimal
 (B) non-terminating decimal
 (C) terminating decimal
 (D) non-terminating, non-repeating decimal

12. If $\sqrt{2}$ and $-\sqrt{2}$ are two zeroes of the polynomial $x^3 - 3x^2 - 2x + 6$, then its third zero is

- (A) $-2\sqrt{2}$ (B) $2\sqrt{2}$
 (C) 3 (D) -3

13. If the equation

$$x^2 - 2x(1 + 3k) + 7(3 + 2k) = 0$$

has equal roots, then k equals

- (A) 2 or $\frac{10}{9}$ (B) -2 or $\frac{10}{9}$
 (C) 2 or $\frac{-10}{9}$ (D) -2 or $\frac{-10}{9}$

14. If the first, second and last terms of an AP are x , y and $2x$ respectively, then the sum of AP is

- (A) $\frac{xy}{2(y-x)}$ (B) $\frac{xy}{y-x}$
 (C) $\frac{3xy}{2(y-x)}$ (D) $\frac{2xy}{y-x}$

15. In the adjoining figure, PQRS is a square and ABC is an equilateral triangle, then $\frac{AR}{SB}$ equals

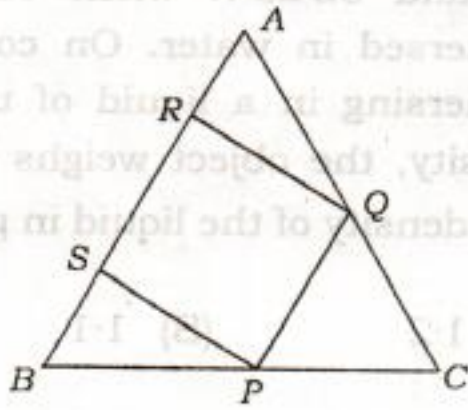

- (A) $\frac{AQ}{BP}$ (B) $\frac{BP}{AQ}$
 (C) $\frac{SB}{AR}$ (D) $\frac{AQ}{QC}$

16. In the given figure, O is the centre of a circle of radius 5 cm. The tangents at A and B meet at P. If OP = 10 cm, then $\angle OAB$ equals

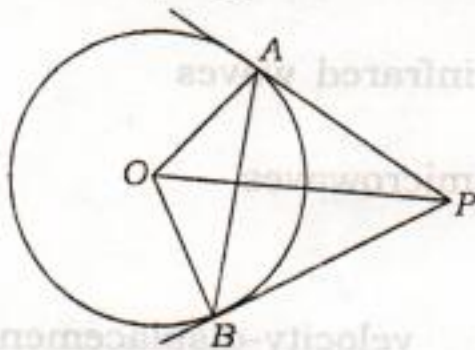

- (A) 25° (B) 60°
 (C) 35° (D) 30°

17. If $\sin A + \cos A = p$ and $\sec A + \operatorname{cosec} A = q$ then $q(p^2 - 1)$ equals

- (A) 2 (B) $\frac{2}{p}$
 (C) $\frac{2}{p^2}$ (D) $2p$

18. The angles of elevation of the top of a tower from two points at a distance of 4 m and 9 m from the base of the tower and in the same straight line with it are complementary. The height of the tower is

- (A) 13 m (B) 5 m
 (C) 36 m (D) 6 m

19. A wire bent in the form of a circle of radius 42 cm is cut and again bent in the form of a square. The ratio of the regions enclosed by the circle and the square in two cases (taking $\pi = \frac{22}{7}$) is

- (A) 11 : 12 (B) 14 : 11
 (C) 21 : 33 (D) 22 : 30

20. The probability for a randomly selected number from 30 to 50 to be a prime number in which both the digits are also prime is

- (A) $\frac{5}{21}$ (B) $\frac{1}{4}$
 (C) $\frac{1}{20}$ (D) $\frac{1}{21}$

SCIENCE

- 21.** Swimming is possible by the application of
- (A) first law of motion
 (B) second law of motion
 (C) third law of motion
 (D) Newton's law of gravitation
- 22.** An object of mass 15 kg is moving with a uniform velocity of 4 ms^{-1} . The kinetic energy possessed by this object is
- (A) 60 J (B) 120 J
 (C) 240 J (D) 480 J
- 23.** The diameter of the earth is 1.6 times that of the planet Mars, while their masses are nearly the same. If a space probe of mass 256 kg lands on the surface of Mars, select the correct statement from the following :
- (A) The weight of the probe on the Mars will be 100 N.
 (B) The mass of the probe on the Mars will be 160 kg.
 (C) The weight of the probe on the Mars will be 1600 N.
 (D) The mass of the probe on the Mars will be 256 kg.
- 24.** A metallic object weighs 36.00 N in air and 32.25 N when completely immersed in water. On completely immersing in a liquid of unknown density, the object weighs 33.00 N. The density of the liquid in g/cm^3 is
- (A) 1.2 (B) 1.1
 (C) 0.9 (D) 0.8
- 25.** The waves used in the echo-ranging method employed to determine depth of the sea are
- (A) ultrasonic waves
 (B) infrasonic waves
 (C) infrared waves
 (D) microwaves
- 26.** The velocity-displacement (v - s) graph for an object which is thrown vertically upwards and falling back to the point from which it was thrown is

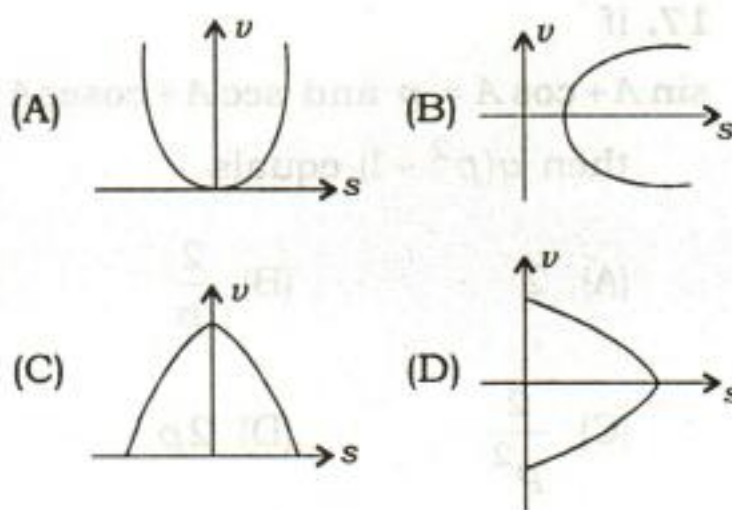

27. Two objects of mass 1 kg and 9 kg have equal kinetic energies. The ratio of their momenta is

- (A) 1 : 3 (B) 3 : 1
(C) 1 : 9 (D) 9 : 1

28. Two cars P and Q move such that car P moving with a uniform velocity of 15 ms^{-1} overtakes car Q moving from rest with an acceleration of 3 ms^{-2} . These cars will meet again after

- (A) 3 s (B) 5 s
(C) 10 s (D) 15 s

29. The three sides of a rectangular block of mass M have dimensions a , b and c respectively. The block is put on the table in three different ways with the sides (i) a and b , (ii) b and c and (iii) c and a on the table top. If the pressures exerted by the block on the table top in the three cases are P_1 , P_2 and P_3 respectively, then which one of the following sets of relations is correct?

(A) $\frac{P_1}{P_2} = \frac{a}{c}$; $\frac{P_2}{P_3} = \frac{b}{a}$

(B) $\frac{P_1}{P_2} = \frac{c}{a}$; $\frac{P_2}{P_3} = \frac{a}{b}$

(C) $\frac{P_1}{P_3} = \frac{c}{a}$; $\frac{P_2}{P_3} = \frac{a}{b}$

(D) $\frac{P_1}{P_3} = \frac{a}{c}$; $\frac{P_2}{P_3} = \frac{a}{b}$

30. We feel more comfortable while sitting on a cushioned sofa than on a hard wooden chair because compared to chair, the sofa exerts

- (A) less force but same pressure on our body
(B) same force but less pressure on our body
(C) less force and less pressure on our body
(D) greater force but less pressure on our body

31. A magnifying glass is used to obtain an enlarged and

- (A) virtual image which is on the same side as the object
(B) real image which is on the same side as the object
(C) virtual image which is on the same side as the observer
(D) real image which is on the same side as the observer

32. An object is placed in front of a spherical mirror which produces an image which is of the same size as the object. If the radius of curvature of the spherical mirror be R , then the distance between the object and its image will be

- (A) $2R$ (B) R
(C) $\frac{1}{2}R$ (D) zero

33. Two plane mirrors are kept perpendicular to each other and an object is placed in front of the mirrors at a point whose distances from them are 3 cm and 4 cm. The distances of the images seen in the mirrors from the object will be

- (A) 3 cm, 4 cm and 5 cm
- (B) 3 cm, 4 cm and 10 cm
- (C) 6 cm, 8 cm and 5 cm
- (D) 6 cm, 8 cm and 10 cm

34. A ray of light PQ is incident on the face AB of an equilateral glass prism ABC . If this ray gets refracted along the direction QR , as shown in the figure, the refractive index of glass of which the prism is made of is

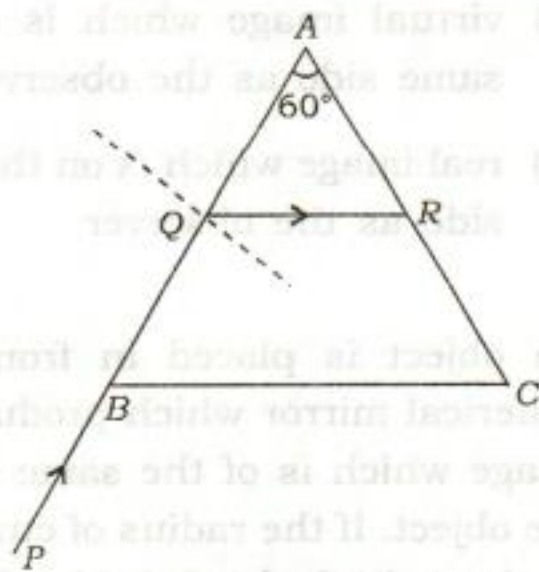

- (A) $\frac{\sqrt{3}}{2}$
- (B) $\frac{3}{\sqrt{2}}$
- (C) 2
- (D) $\frac{4}{\sqrt{3}}$

35. Consider the following statements mentioning the similarities and differences between a camera and human eyes :

1. Both eyes and camera have convex lens.
2. A film in camera is similar to the retina.
3. The camera lens produces upside down real images while the eye lens produces upright real images.
4. In order to focus objects, the eye lens elongates or contracts while the camera lens moves forward or backward.
5. A camera adjusts the amount of light entering in it by adjusting aperture of the lens while in human eye cornea controls the amount of light.

The correct statements are

- (A) 1, 2 and 5 only
- (B) 1, 2 and 4 only
- (C) 1, 2, 4 and 5
- (D) 1, 2 and 3 only

36. A piece of wire of resistance R is cut into four equal parts. These parts are then connected in parallel. If the equivalent resistance of this combination is R' , then the ratio R/R' is

- (A) $\frac{1}{16}$
- (B) $\frac{1}{4}$
- (C) 4
- (D) 16

37. Three resistors of equal resistance connected in series with a battery consume 18 W power. If these resistors are connected in parallel to the same battery, the power consumed by the three resistors would be

- (A) 6 W (B) 54 W
(C) 108 W (D) 162 W

38. In the circuit shown below, the key K is plugged in for 1 minute :

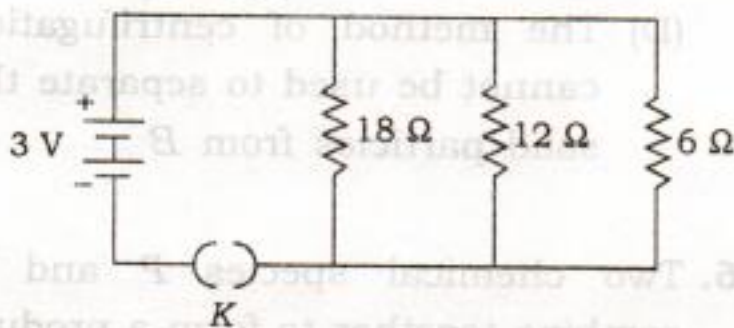

The total electric charge that flows in the circuit in the given time is

- (A) 5 C (B) 12 C
(C) 48 C (D) 55 C

39. Consider the circuit shown below :

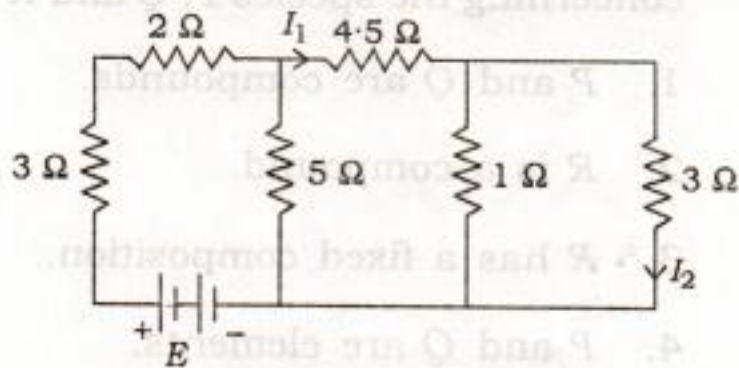

In this circuit the ratio of currents I_1/I_2 is

- (A) $\frac{2}{3}$ (B) $\frac{9}{8}$
(C) $\frac{4}{3}$ (D) 4

40. The magnetic meridian at a place is defined as an imaginary vertical plane passing through that place along the earth's magnetic field. Consider the following two experimental set-ups involving a circular conducting coil with a magnetic needle placed at its centre.

Set-up I :

The coil is placed vertically in a plane along the magnetic meridian.

Set-up II :

The coil is placed vertically, in a plane perpendicular to the magnetic meridian.

When a current is passed through the coil, the magnetic needle would

- (A) show a deflection in Set-up I, but not in Set-up II
(B) show a deflection in Set-up II, but not in Set-up I
(C) show a deflection in both cases
(D) not show a deflection in either case

41. Which of the following is **not** a mixture?

- (A) Air (B) Water
(C) Milk (D) Brass

42. Which of the following will show Tyndall effect?

- (A) Sugar solution
(B) Copper sulphate solution
(C) Soda water
(D) Mist

43. A student obtained the following temperature-time graph for a pure substance which is heated gradually :

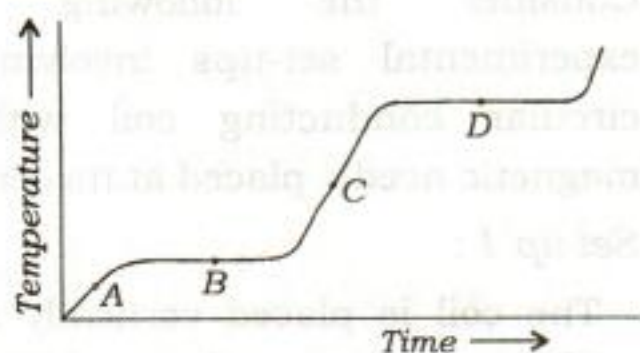

Choose from the following the correct conclusion which can be drawn from the graph.

- (A) The substance is only in gaseous state at point D
- (B) The substance is only in liquid state at point B
- (C) The solid and liquid states of the substance are in equilibrium at point C
- (D) The substance is only in solid state at point A

44. Which of the following is a set of 'pure substances'?

- (A) Air, iodine, iron and seawater
- (B) Oxygen, milk, blood and copper
- (C) Hydrogen, water, sodium chloride and mercury
- (D) Seawater, coal, iron and sodium

45. A, B and C are a suspension, a colloid and a solution respectively. Which one of the following options is correct?

- (A) A is a homogeneous mixture, whereas B and C are heterogeneous
- (B) Tyndall effect can be observed with C
- (C) B can scatter a parallel beam of white light through it
- (D) The method of centrifugation cannot be used to separate the solid particles from B

46. Two chemical species P and Q combine together to form a product R which contain both P and Q

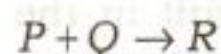

P and Q cannot be broken down into simpler substances by simple chemical processes.

Consider the following statements concerning the species P, Q and R :

1. P and Q are compounds.
2. R is a compound.
3. R has a fixed composition.
4. P and Q are elements.

The correct statements are

- (A) 2 and 3 only
- (B) 2 and 4 only
- (C) 1, 2 and 3
- (D) 2, 3 and 4

47. A student prepared oxide of an element by heating its different amounts in the presence of oxygen and recorded the mass of the product obtained in each case in tabular form as given below :

Sl. No.	Mass of element (g)	Mass of oxide (g)
1	1.2	4.40
2	2.0	7.33
3	3.0	11.00
4	3.2	11.73

Which of the following laws is illustrated by the above observations?

- (A) Avogadro's law
 (B) Law of conservation of mass
 (C) Law of multiple proportion
 (D) Law of constant composition

48. The mass of one atom of an element is nearly 2×10^{-26} kg. The atomic mass of this element in g/mol is nearly

- (A) 6 (B) 12
 (C) 18 (D) 24

49. If an element Y could be obtained by knocking out three neutrons from element X, then

- (A) Y will be an isotope of X
 (B) Y and X will be isobars
 (C) Y will have a higher atomic number than X
 (D) Y will have a lower atomic number than X

50. The sub-atomic particle which is nearly 2000 times heavier than cathode-ray particle but carries no charge is

- (A) tritium (B) deuterium
 (C) proton (D) neutron

51. Consider the reaction :

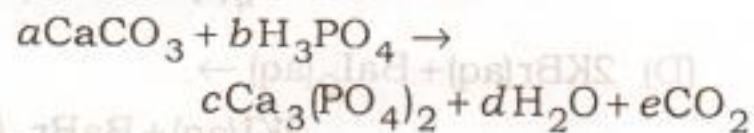

Here a , b , c , d and e are the smallest integer coefficients. The values of a , b , c , d and e respectively should be

- (A) 3, 1, 3, 2 and 3
 (B) 6, 2, 1, 6 and 3
 (C) 6, 2, 3, 2 and 4
 (D) 3, 2, 1, 3 and 3

52. A student took a small amount of silver bromide in a watch glass and placed it in sunlight. After some time, he observed that the white colour of silver bromide changed to grey. Consider the following statements related to this activity :

- White silver bromide changed to grey because of free bromine produced in the reaction.
- This reaction is an example of photo-decomposition reaction.
- This reaction is used in black and white photography.

The correct statement(s) is/are

- (A) 1 only
 (B) 1 and 2 only
 (C) 2 and 3 only
 (D) 1, 2 and 3

53. Which of the following is a redox reaction?

- (A) $\text{CaO(s)} + \text{H}_2\text{O(l)} \rightarrow \text{Ca(OH)}_2\text{(aq)}$
 (B) $\text{MnO}_2\text{(s)} + 4\text{HCl(aq)} \rightarrow \text{MnCl}_2\text{(aq)} + 2\text{H}_2\text{O(l)} + \text{Cl}_2\text{(g)}$
 (C) $\text{Na}_2\text{SO}_4\text{(aq)} + \text{BaCl}_2\text{(aq)} \rightarrow \text{BaSO}_4\text{(s)} + 2\text{NaCl(aq)}$
 (D) $2\text{KBr(aq)} + \text{BaI}_2\text{(aq)} \rightarrow 2\text{KI(aq)} + \text{BaBr}_2\text{(s)}$

54. Setting of plaster of paris into a hard solid mass takes place due to its

- (A) oxidation
 (B) reduction
 (C) dehydration
 (D) hydration

55. Which one of the following is a homologue of ethene?

- (A) $\text{CH}\equiv\text{C}-\text{CH}_2$
 (B) $\text{CH}_2=\text{C}=\text{CH}_2$
 (C) $\text{CH}_2=\text{CH}-\text{CH}_3$
 (D) $\text{CH}_3-\text{CH}_2-\text{CH}_3$

56. Given below is the structure of an oil. This oil reacts with excess of hydrogen in the presence of Ni catalyst. This reaction is called hydrogenation of oils.

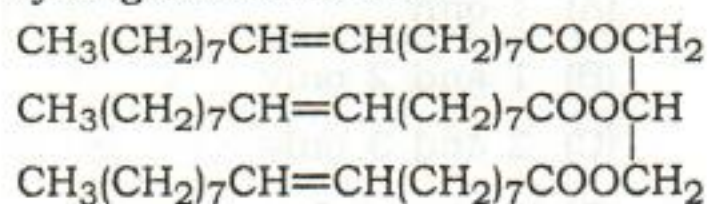

Which of the following changes shall happen in the structure during the reaction?

- (A) Double bonds get converted into single bonds
 (B) Double bonds get converted into triple bonds
 (C) Single bonds get converted into double bonds in the molecule
 (D) Molecule breaks to form smaller molecules from the position of double bonds

57. The functional group present in propanal is

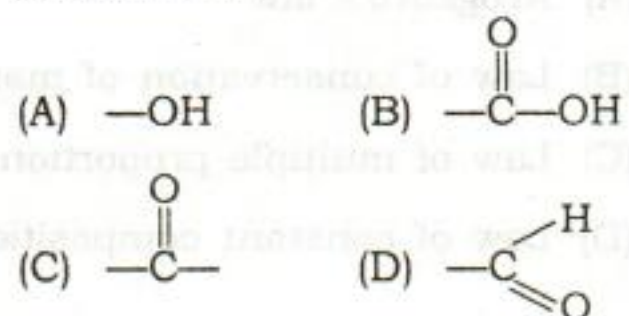

58. Reaction between X and Y, forms a compound Z. X loses electrons and Y gains electrons. Which of the following properties is **not** shown by Z?

- (A) It has high melting point
 (B) It has low melting point
 (C) It conducts electricity in molten state
 (D) It occurs as a solid

59. Which one of the following oxides is basic in nature?

- (A) CO_2 (B) H_2O
 (C) CaO (D) P_2O_5

60. The element with atomic number 21 in modern periodic table is
- an alkali metal
 - an alkaline earth metal
 - a halogen
 - a transition element

61. Girth of stem increases due to
- apical meristem
 - intercalary meristem
 - lateral meristem
 - vertical meristem

62. When a plant cell is placed in a hypertonic solution, without removing its cell wall, it
- bursts
 - plasmolyses
 - swells
 - remains unchanged

63. Bone matrix is rich in
- calcium and phosphorus
 - calcium and potassium
 - calcium and iodine
 - phosphorus and potassium

64. Which one of the following terms includes all the four organisms—ant, lotus, peacock and tiger?
- Animalia
 - Eukaryota
 - Protista
 - Vertebrata

65. Which of the following is responsible for causing ozone hole?
- Carbon monoxide
 - Carbon dioxide
 - Chlorofluorocarbons
 - Hydrofluorocarbons

66. Consider the following statements in the context of manures ;

- Manure contains large quantities of organic matter and small quantities of nutrients.
- Manure increases the water-holding capacity of sandy soil.
- The excessive use of manure pollutes the environment as it is made of animal excretory waste.
- Manure helps in draining out of excess of water from clayey soil.

The correct statements are

- 1, 2 and 3
- 2, 3 and 4
- 1 and 2 only
- 1 and 4 only

67. Which one of the following depicts the correct sequence in nature?

- (A) CO_2 in atmosphere \rightarrow Organic carbon in plants \rightarrow Organic carbon in animals \rightarrow Inorganic carbon in soil
- (B) CO_2 in atmosphere \rightarrow Decomposers \rightarrow Organic carbon in animals \rightarrow Organic carbon in plants
- (C) Inorganic carbonates in water \rightarrow Organic carbon in plants \rightarrow Organic carbon in animals \rightarrow Scavengers
- (D) Organic carbon in animals \rightarrow Decomposers \rightarrow CO_2 in atmosphere \rightarrow Organic carbon in plants

68. Consider the following statements in the context of events that take place during photosynthesis :

1. Absorption of sunlight by guard cells.
2. Conversion of chemical energy into light energy.
3. Reduction of carbohydrates to carbon dioxide.
4. Splitting of water molecule into hydrogen and oxygen.

The correct statement is

- (A) 1
- (B) 2
- (C) 3
- (D) 4

69. The correct sequence of the parts of a nerve cell through which an electrical impulse travels to the muscle is

- (A) Cell body \rightarrow Dendrite \rightarrow Axon \rightarrow Nerve ending
- (B) Dendrite \rightarrow Nucleus \rightarrow Axon \rightarrow Neuromuscular junction
- (C) Cell body \rightarrow Dendrite \rightarrow Axon \rightarrow Synapse
- (D) Dendrite \rightarrow Cell body \rightarrow Axon \rightarrow Neuromuscular junction

70. Plasmodium is reproduced by

- (A) multiple fission
- (B) budding
- (C) fragmentation
- (D) binary fission

71. The evolutionary theory is based on the fact that new species are formed by

- (A) migration of different species from one habitat to another
- (B) accumulation of variations generation after generation
- (C) sudden creation by nature
- (D) clones formed due to asexual reproduction

72. In our country, women in many societies get their ear/nose pierced for wearing ornaments since centuries, but still girls are not born with piercing in these organs. Which of the following statements provides the suitable reason for it?
- (A) Acquired characters cannot be inherited.
- (B) Only the major changes brought about by environment can be inherited.
- (C) Acquired characters can be inherited only if the will of the individual is very strong.
- (D) This character cannot be inherited since it is not classified under acquired characters.
73. Stanley L. Miller and Harold C. Urey conducted an experiment in 1953 to understand how life might have evolved from the simple inorganic molecules which were present on the earth soon after it was formed. They passed electric spark through a mixture of elements/compounds maintained just below 100 °C.
- Which among the following were present in the starting mixture?
1. Ammonia
 2. Amino acids
 3. Methane
 4. Oxygen
- (A) 1 and 2 only
- (B) 1 and 3 only
- (C) 3 and 4 only
- (D) 1, 3 and 4 only
74. In a nuclear fission reaction, it was observed that the mass of the products was 4 g less than the mass of the reactants. The energy released in the reaction would be nearly
- (A) 10^6 kWh (B) 10^7 kWh
- (C) 10^8 kWh (D) 10^9 kWh
75. Ocean thermal energy, tidal energy and wave energy are the forms of energy that man can harness from seas and oceans. Currently, there is negligible exploitation of these huge natural resources. The most likely reason is
- (A) that the most of the energy demand is in land areas
- (B) that the available energy is far less than the current energy demand
- (C) that the availability is seasonal and hence cannot be relied upon
- (D) lack of technology for efficient harnessing of this resource

SPACE FOR ROUGH WORK

- (A) 1 and 3 only
- (B) 1 and 4 only
- (C) 2 and 4 only
- (D) 1, 3 and 4 only

74. In a nuclear fission reaction, it was observed that the mass of the products was 4 g less than the mass of the reactants. The energy released in the reaction would be nearly

- (A) 10^6 kWh (B) 10^7 kWh
- (C) 10^8 kWh (D) 10^9 kWh

75. Ocean thermal energy, tidal energy and wave energy are the forms of energy that man can harness from seas and oceans. Currently, there is negligible exploitation of these huge natural resources. The most likely reason is

- (A) that the most of the energy demand is in land areas
- (B) that the available energy is far less than the current energy demand
- (C) that the availability is seasonal and hence cannot be relied upon
- (D) lack of technology in efficient harnessing of this resource

72. In our country, women societies for their villages since for wearing ornaments - since countries, but still girls are not doing with playing in these organs. Which of the following statements provides the suitable reason for it?

- (A) Acquired characters cannot be inherited
- (B) Only the major changes brought about by environment can be inherited
- (C) Acquired characters can be inherited only if the will of the individual is very strong
- (D) This character cannot be inherited since it is not classified under acquired characters

73. Stanley L. Miller and Harold C. Urey conducted an experiment in 1953 to understand how life might have evolved from the simple inorganic molecules which were present on the earth soon after it was formed. They passed electric spark through a mixture of chemical compounds maintained just below 100°C .

Which among the following were present in the starting mixture?

1. Ammonia
2. Amino acids
3. Methane
4. Oxygen

SEAL