

CIVIL ENGINEERING

ONE MARKS QUESTIONS

1. A mild steel specimen is under uniaxial tensile stress. Young's modulus and yield stress for mild steel are 2×10^5 MPa and 250 MPa respectively. The maximum amount of strain energy per unit volume that can be stored in this specimen without permanent set is
 - a. 156 Nmm/mm^3
 - b. 15.6 Nmm/mm^3
 - c. 1.56 Nmm/mm^3
 - d. 0.156 Nmm/mm^3
2. A reinforced concrete structure has to be constructed along a sea coast. The minimum grade of concrete to be used as per IS: 456-2000 is
 - a. M 15
 - b. M 20
 - c. M 25
 - d. M 30
3. In the design of a reinforced concrete beam the requirement for bond is not getting satisfied. The economical option to satisfy the requirement for bond is by
 - a. bundling of bars
 - b. providing smaller diameter bars more in number
 - c. providing larger diameter bars less in number
 - d. providing same diameter bars more in number
4. The shape of the cross-section, which has the least shape factor, is
 - a. rectangular
 - b. I-section
 - c. diamond
 - d. solid circular
5. Group symbols assigned to silty sand and clayey sand are respectively
 - a. SS and CS
 - b. SM and CS
 - c. SM and SC
 - d. MS and CS
6. When a retaining wall moves away from the backfill, the pressure exerted on the wall is termed as
 - a. passive earth pressure
 - b. swelling pressure
 - c. pore pressure
 - d. active earth pressure
7. Compaction by vibratory roller is the best method of compaction in case of
 - a. moist silty sand
 - b. well graded dry sand
 - c. clay of medium compressibility
 - d. silt of high compressibility
8. Two primary air pollutants are
 - a. sulphur oxide and ozone
 - b. nitrogen oxide and peroxyacetylnitrate
 - c. sulphur oxide and hydrocarbon
 - d. ozone and peroxyacetylnitrate
9. Two biodegradable components of municipal solid waste are
 - a. plastics and wood
 - b. cardboard and glass
 - c. leather and tin cans
 - d. food wastes and garden trimmings
10. A flood wave with a known inflow hydrograph is routed through a large reservoir. The outflow hydrograph will have
 - a. attenuated peak with reduced time base
 - b. attenuated peak with increased time-base
 - c. increased peak with increased time-base
 - d. increased peak with reduced time-base
11. A stable channel is to be designed for a discharge of $Q \text{ m}^3/\text{s}$ with silt factor f as per Lacey's method. The mean flow velocity (m/s) in the channel is obtained by
 - a. $(Qf^2/140)^{1/6}$
 - b. $(Qf/140)^{1/3}$
 - c. $(Q^2f^2/140)^{1/6}$
 - d. $0.48(Q/f)^{1/3}$
12. The base width of an elementary profile of a gravity dam of height H is b . The specific gravity of the material of the dam

is G and uplift pressure coefficient is K . The correct relationship for no tension at the heel is given by

- a. $\frac{b}{H} = \frac{1}{\sqrt{G-K}}$
 b. $\frac{b}{H} = \sqrt{G-K}$
 c. $\frac{b}{H} = \frac{1}{G-K}$
 d. $\frac{b}{H} = \frac{1}{K\sqrt{G-K}}$
13. The specific gravity of paving bitumen as per IS : 73-1992 lies between
 a. 1.10 and 1.06
 b. 1.06 and 1.02
 c. 1.02 and 0.97
 d. 0.97 and 0.92
14. A combined value of flakiness and elongation index is to be determined for a sample of aggregates. The sequence in which the two tests are conducted is
 a. elongation index test followed by flakiness index test on the whole sample
 b. flakiness index test followed by elongation index test on the whole sample
 c. flakiness index test followed by elongation index test on non-flaky aggregates
 d. elongation index test followed by flakiness index test on non-elongated aggregates
15. The capacities of "One-way 1.5 m wide sidewalk (persons per hour)" and "One-way 2-lane urban road (PCU per hour, with no frontage access, no standing vehicles and very little cross traffic)" are respectively
 a. 1200 and 2400
 b. 1800 and 2000
 c. 1200 and 1500
 d. 2000 and 1200
16. The shape of the STOP sign according to **IRC : 67-2001** is
 a. circular
 b. triangular
 c. octagonal
 d. rectangular

17. The type of surveying in which the curvature of the earth is taken into account is called
 a. Geodetic surveying
 b. Plane surveying
 c. Preliminary surveying
 d. Topographical surveying
18. A person standing on the bank of a canal drops a stone on the water surface. He notices that the disturbance on the water surface is not traveling upstream. This is because the flow in the canal is
 a. sub-critical
 b. super-critical
 c. steady
 d. uniform
19. The product of matrices $(PQ)^{-1}P$ is
 a. P^{-1}
 b. Q^{-1}
 c. $P^{-1}Q^{-1}P$
 d. $PQ P^{-1}$
20. The general solution of $\frac{d^2y}{dx^2} + y = 0$ is
 a. $y = P \cos x + Q \sin x$
 b. $y = P \cos x$
 c. $y = P \sin x$
 d. $y = P \sin^2 x$

TWO MARKS QUESTIONS

21. Cross-section of a column consisting of two steel strips, each of thickness t and width b is shown in the figure below. The critical loads of the column with perfect bond and without bond between the strips are P and P_0 respectively. The ratio P/P_0 is

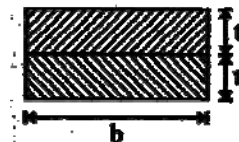

- a. 2
 b. 4
 c. 6
 d. 8
22. A rigid bar GH of length L is supported by a hinge and a spring of stiffness K as

shown in the figure below. The buckling load, P_{Cr} , for the bar will be



- $0.5 KL$
- $0.8 KL$
- $1.0 KL$
- $1.2 KL$

23. The maximum shear stress in a solid shaft of circular cross-section having diameter subjected to a torque T is τ . If the torque is increased by four times and the diameter of the shaft is increased by two times, the maximum shear stress in the shaft will be

- 2τ
- τ
- $\tau/2$
- $\tau/4$

24. A vertical rod PQ of length L is fixed at its top end P and has a flange fixed to the bottom end Q. A weight W is dropped vertically from a height $h (< L)$ onto the flange. The axial stress in the rod can be reduced by

- increasing the length of the rod
- decreasing the length of the rod
- decreasing the area of cross-section of the rod
- increasing the modulus of elasticity of the material

25. The maximum tensile stress at the section X-X shown in the figure below is V

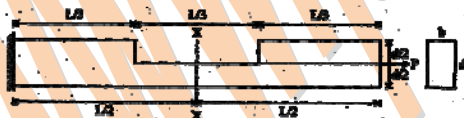

- $\frac{8P}{bd}$
- $\frac{6P}{bd}$
- $\frac{4P}{bd}$
- $\frac{2P}{bd}$

26. The stepped cantilever is subjected to moments, M as shown in the figure below. The vertical deflection at the free end (neglecting the self weight) is

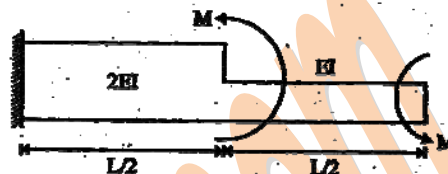

- $\frac{ML^2}{8EI}$
- $\frac{ML^2}{4EI}$
- $\frac{ML^2}{2EI}$
- Zero

Data for linked answer questions Q.27 & Q. 28 are given below. Solve the problems and choose the correct answers.

Beam GNI is supported by three pontoons as shown in the figure below. The horizontal cross-sectional area of each pontoon is 8 m^2 , the flexural rigidity of the beam is 10000 kN-m^2 and the unit weight of water is 10 kN/m^3 .

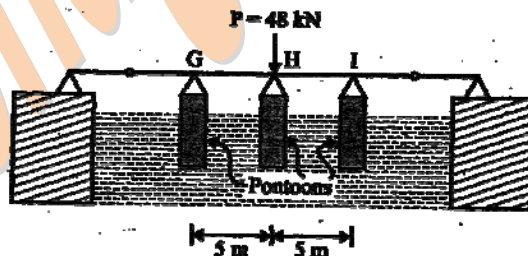

27. When the middle pontoon is removed, the deflection at H will be

- 0.2 m
- 0.4 m
- 0.6 m
- 0.8 m

28. When the middle pontoon is brought back to its position as shown in the figure above, the reaction at H will be

- 8.6 kN
- 15.7 kN
- 19.2 kN
- 24.2 kN

29. The degree of static indeterminacy of the rigid frame having two internal hinges as shown in the figure below, is

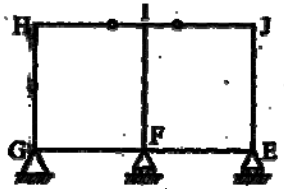

- a. 8
- b. 7
- c. 6
- d. 5

30. The members E.J and IJ of a steel truss shown in the figure below are subjected to temperature rise of 30°C . The coefficient of thermal expansion of steel is 0.000012 per $^\circ\text{C}$ per unit length. The displacement (mm) of joint E relative to joint H along the direction HE of the truss, is

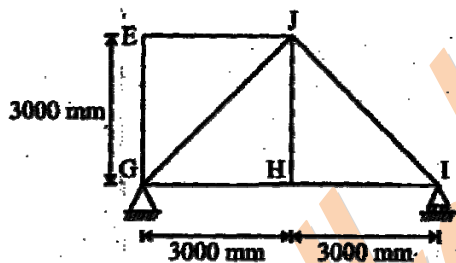

- a. 0.255
- b. 0.589
- c. 0.764
- d. 1.026

31. The span(s) to be loaded uniformly for maximum positive (upward) reaction at support P, as shown in the figure below, is(are)

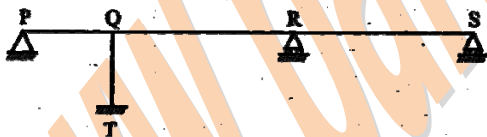

- a. PQ only
- b. PQ and QR
- c. QR and RS
- d. PQ and RS

32. Un-factored maximum bending moments at a section of a reinforced concrete beam resulting from a frame analysis are 50,80,120 and 180 kNm under dead, live, wind and earthquake loads respectively. The design moment (kNm) as per IS:456-2000 for the limit state of collapse (flexure) is

- a. 195
- b. 250

- c. 345
- d. 372

33. A reinforced concrete column contains longitudinal steel equal to 1 percent of net cross-sectional area of the column. Assume modular ratio as 10. The loads carried (using the elastic theory) by the longitudinal steel and the net area of concrete, are P_s and P_c respectively. The ratio P_s/P_c expressed as per cent is

- a. 0.1
- b. 1
- c. 1.1
- d. 10

34. A pre-tensioned concrete member of section $200\text{ mm} \times 250\text{ mm}$ contains tendons of area 500 mm^2 at centre of gravity of the section. The prestress in the tendons is 1000 N/mm^2 . Assuming modular ratio as 10, the stress (N/mm^2) in concrete is

- a. 11
- b. 9
- c. 7
- d. 5

Data for Q. 34 & Q. 36 are given below. Solve the problem and choose the correct answers.

A reinforced concrete beam of rectangular cross section of breadth 230 mm and effective depth 300 mm is subjected to a maximum factored shear force of 120 kN . The grades of concrete, main steel and stirrup steel are M20, Fe415 and Fe250 respectively. For the area of main steel provided, the design shear strength as per IS : 456-2000 is 0.48 N/mm^2 . The beam is designed for collapse limit state.

35. The spacing (mm) of 2-legged 8 mm stirrups to be provided is

- a. 40
- b. 115
- c. 250
- d. 400

36. In addition, the beam is subjected to a torque whose factored value is 01.90 kNm . The stirrups have to be provided to carry a shear (kN) equal to

- a. 50.42
- b. 130.56
- c. 151.67
- d. 200.23

37. Rivets and bolts subjected to both shear stress ($\tau_{vf,cal}$) and axial tensile stress ($\sigma_{tf,cal}$) shall be so proportioned that the stresses do not exceed the respective allowable stresses τ_{vf} and σ_{tf} and the value of

$$\left(\frac{\tau_{vf,cal}}{\tau_{vf}} + \frac{\sigma_{tf,cal}}{\sigma_{tf}} \right) \text{ does not exceed}$$

- a. 1.0
b. 1.2
c. 1.4
d. 1.8
38. A continuous beam is loaded as shown in the figure below. Assuming a plastic moment capacity equal to M , the minimum load at which the beam would collapse is

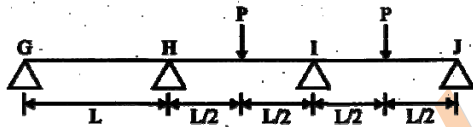

- a. $\frac{4M_p}{L}$
b. $\frac{6M_p}{L}$
c. $\frac{8M_p}{L}$
d. $\frac{10M_p}{L}$
39. The liquid limit (LL), plastic limit (PL) and shrinkage limit (SL) of a cohesive soil satisfy the relation
- a. $LL > PL < SL$
b. $LL > PL > SL$
c. $LL < PL < SL$
d. $LL < PL > SL$
40. A footing $2\text{m} \times 1\text{m}$ exerts a uniform pressure of 150kN/m^2 on the soil. Assuming a load dispersion of 2 vertical to 1 horizontal, the average vertical stress (kN/m^2) at 1.0 m below the footing is
- a. 50
b. 75
c. 80
d. 100
41. A direct shear test was conducted on a cohesionless soil ($c = 0$) specimen under a normal stress of 200kN/m^2 . The specimen failed at a shear stress of 100kN/m^2 . The angle of internal friction of the soil (degrees) is

- a. 26.6
b. 29.5
c. 30.0
d. 32.6

42. A pile of 0.50 m diameter and of length 10 m is embedded in a deposit of clay. The undrained strength parameters of the clay are cohesion = 60kN/m^2 and the angle of internal friction = 0. The skin friction capacity (kN) of the pile for an adhesion factor of 0.6, is

- a. 671
b. 565
c. 283
d. 106

43. A saturated clay stratum draining both at the top and bottom undergoes 50 percent consolidation in 16 years under an applied load. If an additional drainage layer were present at the middle of the clay stratum, 50 percent consolidation would occur in

- a. 2 years
b. 4 years
c. 8 years
d. 16 years

44. A test plate $30\text{cm} \times 30\text{cm}$ resting on a sand deposit settles by 10 mm under a certain loading intensity. A footing $150\text{cm} \times 200\text{cm}$ resting on the same sand deposit and loaded to the same load intensity settles by

- a. 2.0 mm
b. 30.2mm
c. 27.8mm
d. 50.0 mm

45. A volume of $3.0 \times 10^6\text{m}^3$ of groundwater was pumped out from an unconfined aquifer uniformly from an area of 5km^2 . The pumping lowered the water table from initial level of 102 m to 99 m. The specific yield of the aquifer is

- a. 0.20
b. 0.30
c. 0.40
d. 0.50

Data for linked answer questions Q. 46 & Q.47 are given below. Solve the problems and choose the correct answers.

The ground conditions at a site are shown in the figure below.

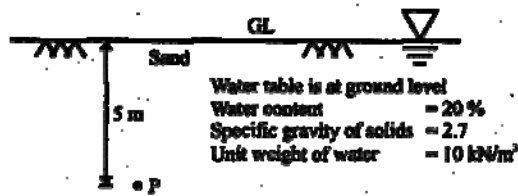

46. The saturated unit weight of the sand (kN/m³) is
- 15
 - 18
 - 21
 - 24
47. The total stress, pore water pressure and effective stress (kN/m²) at the point P are, respectively
- 75, 50 and 25
 - 90, 50 and 40
 - 105, 50 and 55
 - 120, 50 and 70

Data for linked answer questions Q. 48 & Q.49 are given below. Solve the problems and choose the correct answers.

A column is supported on a footing as shown in the figure below. The water table is at a depth of 10 m below the base of the footing.

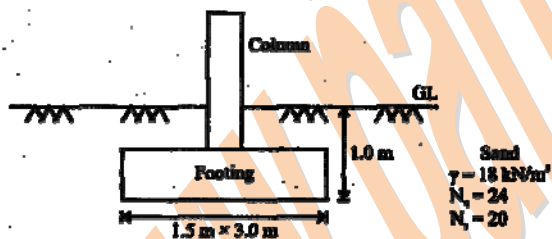

48. The net ultimate bearing capacity (kN/m²) of the footing based on Terzaghi's bearing capacity equation is
- 216
 - 432
 - 630
 - 846
49. The safe load (kN) that the footing can carry with a factor of safety 3 is
- 282
 - 648
 - 945

- d. 1269
50. A wastewater sample contains $10^{-5.6}$ mol/l of OH⁻ ions at 25°C. The pH of this sample is
- 8.6
 - 8.4
 - 5.6
 - 5.4
51. Match List-I (Estimation method) with List-II (Corresponding indicator) and select the correct answer using the codes given below the list :

List-I

P. Azide modified Winkler method for dissolved oxygen

Q. Dichromate method for chemical oxygen demand

R. EDTA titrimetric method for hardness

S. Mohr or Argentometric method for chlorides

List-II

1. Eriochrome Black T

2. Ferroin

3. Potassium chromate

4. Starch

	P	Q	R	S
a.	3	2	1	4
b.	4	2	1	3
c.	4	1	2	3
d.	4	2	3	1

52. Determine the correctness or otherwise of the following Assertion [A] and the Reason [R]

Assertion: The crown of the outgoing larger diameter sewer is always matched with the crown of incoming smaller diameter sewer.

Reason: It eliminates backing up of sewage in the incoming smaller diameter sewer.

- Both [A] and [R] are true and [R] is the correct reason for [A]
- Both [A] and [R] are true but [R] is not the correct reason for [A]
- Both [A] and [R] are false
- [A] is true but [R] is false

53. The 5-day BOD of a waste water sample is obtained as 190mg/l (with $k = 0.01 \text{ h}^{-1}$). The ultimate oxygen demand (mg/l) of the sample will be

- a. 3800
- b. 475
- c. 271
- d. 190

54. A water treatment plant is required to process $28800 \text{ m}^3/\text{d}$ of raw water (density = 1000 kg/m^3 , kinematic viscosity = $10^{-6} \text{ m}^2/\text{s}$). The rapid mixing tank imparts a velocity gradient of 900 s^{-1} to blend 35 mg/l of alum with the flow for a detention time of 2 minutes. The power input (W) required for rapid mixing is

- a. 32.4
- b. 36
- c. 324
- d. 32400

55. Match List-I (Terminology) with List-II (Definition/Brief Description) and select the correct answer using the codes given below the lists:

List-I

P. Primary treatment

Q. Secondary treatment

R. Unit operation

S. Unit process

List-II

1. Contaminant removal by physical forces
2. Involving biological and/or chemical reaction
3. Conversion of soluble organic matter to biomass
4. Removal of solid materials from incoming waste water

Codes:

- | | P | Q | R | S |
|----|---|---|---|---|
| a. | 4 | 3 | 1 | 2 |
| b. | 4 | 3 | 2 | 1 |
| c. | 3 | 4 | 2 | 1 |
| d. | 1 | 2 | 3 | 4 |

56. A weir on a permeable foundation with downstream sheet pile is shown in the figure below. The exit gradient as per Khosla's method

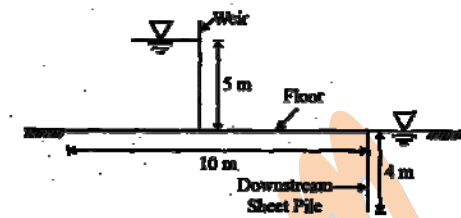

- a. 1 in 6.0
- b. 1 in 5.0
- c. 1 in 3.4
- d. 1 in 2.5

57. Water emerges from an ogee spillway with velocity = 13.72 m/s and depth = 0.3 m at its toe. The tail water depth required to form a hydraulic jump at the toe is

- a. 6.48 m
- b. 5.24 m
- c. 3.24 m
- d. 2.24 m

58. An outlet irrigates an area of 20 ha. The discharge (l/s) required at this outlet to meet the evapotranspiration requirement of 20mm occurring uniformly in 20 days neglecting other field losses is

- a. 2.52
- b. 2.31
- c. 2.01
- d. 1.52

59. A roundabout is provided with an average entry width of 8.4 m, width of weaving section as 14 m, and length of the weaving section between channelizing islands as 35m. The crossing traffic and total traffic on the weaving section are 1000 and 2000 PCU per hour respectively. The nearest rounded capacity of the roundabout (in PCU per hour) is

- a. 3300
- b. 3700
- c. 4500
- d. 5200

60. Design parameters for a signalized intersection are shown in the figure below. The green time calculated for major and minor roads are 34 and 18s, respectively.

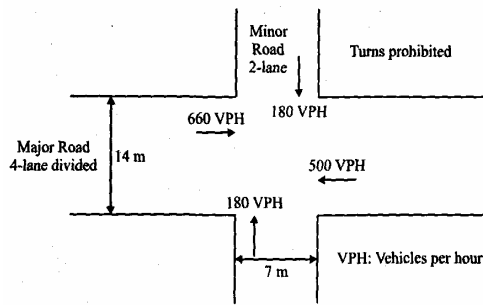

The critical lane volume on the major road changes to 444) vehicles per hour per lane and the critical lane volume on the minor road remain unchanged. The green time will

- increase for the major road and remain same for the minor road.
 - increase for the major road and decrease for the minor road.
 - decrease for both the roads.
 - remain unchanged for both the roads.
61. It is proposed to widen and strengthen an existing 2-lane NH section as a divided highway. The existing traffic in one direction is 2500 commercial vehicles (CV) per thy. The construction will take 1 year. The design CBR of soil subgrade is found to be 5 per cent. Given: traffic growth rate for CV = 8 percent, vehicle damage factor = 3.5 (standard axles per CV), design life = 10 years and traffic distribution factor = 0.75. The cumulative standard axles (msa) computed are
- 35
 - 37
 - 65
 - 70
62. A linear relationship is observed between speed and density on a certain section of a highway. The free flow speed is observed to be 80km per hour and the jam density is estimated as 100 vehicles per 1cm length. Based on the above relationship, the maximum flow expected on this section and the speed at the maximum flow will respectively be
- 8000 vehicles per hour and 80km per hour
 - 8000 vehicles per hour and 25 km per hour
 - 2000 vehicles per hour and 80km per hour

d. 2000 vehicles per hour and 40 km per hour

63. The plan of a survey plotted to a scale of 10 m to 1 cm is reduced in such a way that a line originally 10cm long now measures 9cm. The area of the reduced plan is measured as 81 cm². The actual area (m²) of the survey is
- 10000
 - 6561
 - 1000
 - 656
64. The lengths and bearings of a closed traverse PQRSP are given below.

Line	Length(m)	Bearing(WCB)
PQ	200	0°
QR	1000	45°
RS	907	180°
SP	?	?

The missing length and bearing, respectively of the line SP are

- 207 m and 270°
 - 707 m and 270°
 - 707 m and 180°
 - 907 m and 270°
65. The focal length of the object glass of a tacheometer is 200 mm, the distance between the vertical axis of the tacheometer and the optical centre of the object glass is 100mm and the spacing between the upper and lower line of the diaphragm axis is 4mm. With the line of collimation perfectly horizontal, the staff intercepts are 1 m (top), 2 m (middle), and 3 m (bottom). The horizontal distance (m) between the staff and the instrument station is
- 100.3
 - 103.0
 - 150.0
 - 153.0
66. A road is provided with a horizontal circular curve having deflection angle of 55° and centre line radius of 250 m. A transition curve is to be provided at each end of the circular curve of such a length that the rate of gain of radial acceleration is 0.3 m/s³ at a speed of 50 km per bout Length of the transition curve required at each of the ends is
- 2.57 m

- b. 33.33 m
c. 35.73 m
d. 1666.67 m
67. A light house of 120 m height is just visible above the horizon from a ship. The correct distance (m) between the ship and the light house considering combined correction for curvature and refraction, is
- a. 39.098
b. 42.226
c. 39098
d. 42226

Data for linked answer questions Q. 68 & Q.69 are given below. Solve the problems and choose the correct answers.

A horizontal circular curve with a centre line radius of 200 m provided on a 2-lane, 2-way SH section. The width of the 2-lane road is 7.0 m. Design speed for this section is 80 km per hour. The brake reaction time is 2.4s, and the coefficients of friction in longitudinal and lateral directions are 0.355 and 0.15, respectively.

68. The safe stopping sight distance on the section is
- a. 221 m
b. 195 m
c. 125 m
d. 65 m
69. The set-back distance from the centre line of the inner lane is
- a. 7.93 m
b. 8.10 m
c. 9.60 m
d. 9.77 m
70. The flow of water (mass density = 1000 kg/m³ and kinematic viscosity = 10m²/s) in a commercial pipe, having equivalent roughness k_s as 0.12 mm, yields an average shear stress at the pipe boundary = 600 N/m². The value of k_s/δ' (δ' being the thickness of laminar sub-layer) for this pipe is
- a. 0.25
b. 0.50
c. 6.0
d. 8.0
71. A river reach of 2.0 km long with maximum flood discharge of 10000 m³/s is

to be physically modeled in the laboratory where maximum available discharge is 020 m³/s. For a geometrically similar model based on equality of Froude number, the length of the river reach (m) in the model is

- a. 26.4
b. 25.0
c. 20.5
d. 18.0

Data for Q.72 and Q.73 are given below. Solve the problems and choose correct answers.

A rectangular channel 6.0 m wide carries a discharge of 16.0 m³/s under uniform flow condition with normal depth of 1.60 m. Manning's 'n' is 0.015.

72. The longitudinal slope of the channel is
- a. 0.000585
b. 0.000485
c. 0.000385
d. 0.000285
73. A hump is to be provided on the channel bed. The maximum height of the hump without affecting the upstream flow condition is
- a. 0.50 m
b. 0.40 m
c. 0.30 m
d. 0.20 m
74. The channel width is to be contracted. The minimum width to which the channel can be contracted without affecting the upstream flow condition is
- a. 3.0 m
b. 3.8 m
c. 4.1 m
d. 4.5 m

Data for linked answer questions Q.75 and Q.76 are given below. Solve the problems and choose correct answers.

An automobile with projected area 2.6 m² is running on a road with a speed of 120 km per hour. The mass density and the kinematic viscosity of air are 12kg/m³ and 1.5×10^{-5} m²/s, respectively. The drag coefficient is 0.30.

75. The drag force on the automobile is

- a. 620 N
b. 600 N
c. 580 N
d. 520 N
76. The metric horse power required to overcome the drag force is
a. 33.23
b. 31.23
c. 23.23
d. 20.23
77. The equation $k_x \frac{\partial^2 h}{\partial x^2} + k_z \frac{\partial^2 h}{\partial z^2} = 0$ can be transformed to $\frac{\partial^2 h}{\partial x_t^2} + \frac{\partial^2 h}{\partial z^2} = 0$ by substituting
a. $x_t = x \frac{k_z}{k_x}$
b. $x_t = x \frac{k_x}{k_z}$
c. $x_t = x \sqrt{\frac{k_x}{k_z}}$
d. $x_t = x \sqrt{\frac{k_z}{k_x}}$
78. The value of $\int_0^3 \int_0^x (6 - x - y) dx dy$ is
a. 13.5
b. 27.0
c. 40.5
d. 54.0
79. Three values of x and y are to be fitted in a straight line in the form $y = a + bx$ by the method of least squares. Given $\Sigma x = 6$, $\Sigma y = 21$, $\Sigma x^2 = 14$ and $\Sigma xy = 46$, the values of a and b are respectively
a. 2 and 3
b. 1 and 2
c. 2 and 1
d. 3 and 2
80. Solution of $\frac{dy}{dx} = -\frac{x}{y}$ at $x = 1$ and $y = \sqrt{3}$ is
a. $x - y^2 = -2$
b. $x + y^2 = 4$
c. $x^2 - y^2 = -2$
d. $x^2 + y^2 = 4$
81. If probability density function of a random variable X is
 $f(x) = x^2$ for $-1 \leq x \leq 1$, and
 $= 0$ for any other value of x
then, the percentage probability
 $P\left(-\frac{1}{3} \leq x \leq \frac{1}{3}\right)$ is
a. 0.247
b. 2.47
c. 24.7
d. 247
82. The Eigen values of the matrix $[P] = \begin{bmatrix} 4 & 5 \\ 2 & -5 \end{bmatrix}$ are
a. -7 and 8
b. -6 and 5
c. 3 and 4
d. 1 and 2
83. A person on a trip has a choice between private car and public transport. The probability of using a private car is 0.45. While using the public transport, further choices available are bus and metro, out of which the probability of commuting by a bus is 0.55. In such a situation, the probability (rounded up to two decimals) of using a car, bus and metro, respectively would be
a. 0.45, 0.30 and 0.25
b. 0.45, 0.25 and 0.30
c. 0.45, 0.55 and 0.00
d. 0.45, 0.35 and 0.20
84. The following simultaneous equations
 $x + y + z = 3$
 $x + 2y + 3z = 4$
 $x + 4y + kz = 6$
will NOT have a unique solution for k equal to
a. 0
b. 5
c. 6
d. 7
85. The inner (dot) product of two vectors \vec{P} and \vec{Q} is zero. The angle (degrees) between the two vectors is
a. 0
b. 30
c. 90
d. 120