

1. Interrupt latency is the time elapsed between:
- Occurrence of an interrupt and its detection by the CPU
  - Assertion of an interrupt and the start of the associated ISR
  - Assertion of an interrupt and the completion of the associated ISR
  - Start and completion of associated ISR
2. Inverse Fourier transform of signal  $X(j\omega) = 2\pi\delta(\omega) + \pi\delta(\omega - 4\pi) + \pi\delta(\omega + 4\pi)$
- $1 + \cos 4\pi t$
  - $\pi(1 - \cos 4\pi t)$
  - $2\pi(1 - \cos 4\pi t)$
  - $2\pi(1 + \cos 4\pi t)$
3. Determine the discrete-time Fourier Transform for the signal  $x[n] = [-2, -1, 0, 1, 2]$
- 
- $2j(2\sin 2\omega + \sin \omega)$
  - $-2j(2\sin 2\omega + \sin \omega)$
  - $2(2\cos 2\omega - \cos \omega)$
  - $-2(2\cos 2\omega - \cos \omega)$
4. Auto-correlation of a sinusoid  $s(t) = A \sin(\omega t)$  is
- $(A^2/2) \sin(\omega\tau)$
  - $(A/2) \sin(\omega\tau)$
  - $(A^2/2) \cos(\omega\tau)$
  - $(A/2) \cos(\omega\tau)$
5. A source produces 4 symbols with probabilities  $1/2, 1/4, 1/8, 1/8$ . For this source, a practical coding scheme has an average codeword length of 2 bits/symbol. The efficiency of the code is
- 1
  - $7/8$
  - $1/2$
  - $1/4$
6. When signal frequency is 2000 KHz and IF is 455 KHz, the image frequency could be
- 2910 KHz
  - 1645 KHz
  - 2455 KHz
  - 2090 KHz

7. The Q of RLC tuned circuit with source voltage  $V$  in the figure is 100 at resonant frequency of 100 KHz. What is the voltage  $V_L$  across inductor at resonance?

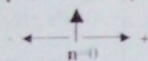
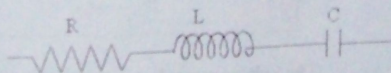

- 50V
- $V_L - V_C$
- 100V
- $V_R - V_C$

- 8 A 5V reference is drawn from the circuit shown in the figure. Zener diode of 400mW and 5V with firing current of 5mA is used. The value of  $R_s$  is

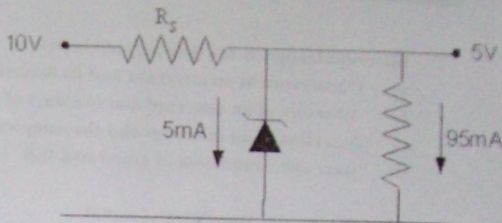

- a) 50 ohms      b) 500 ohms

c) 75 ohms

d) 470 ohms

- 9 Find the equivalent resistance  $R$  for the network shown in the figure.

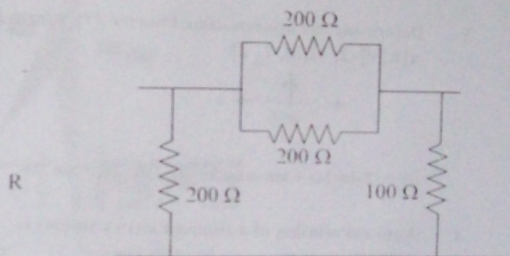

a) 200 ohms

b) 101 ohms

c) 220 ohms

d) 100 ohms

10

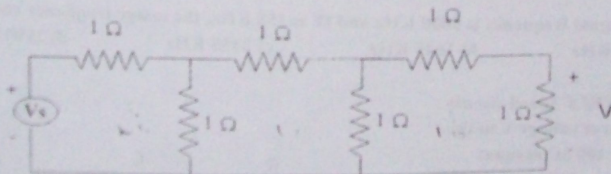

The Voltage across last resistor is  $V$ . All resistors are unity. Then  $V_s$  is given by

a) 13 V

b) 8 V

c) 4 V

d) None of these

- 11 Natural frequency of a unity feedback control system of transfer function

$$G(s) = \frac{10}{s(s+1)} + 10$$

a) 0.5 rad/sec

b) 3.16 rad/sec

c) 4.6 rad/sec

d) None of these

- 12 Which of the following conditions will not guarantee a distortionless transmission line?
- $R = 0, G = 0$
  - Very low frequency range ( $R \gg \omega L, G \gg \omega C$ )
  - $R/L = G/C$ .
  - Very high frequency range ( $R \ll \omega L, G \ll \omega C$ ).
- 13 For a line of characteristic impedance  $Z_0$  terminated in a load  $Z_R$  such that  $Z_R > Z_0$ , the Voltage Standing Wave Ratio (VSWR) is given by
- $Z_R/Z_0$
  - $Z_0$
  - $Z_R$
  - $Z_0/Z_R$
- 14 The beamwidth of a reflector antenna of diameter = 70 cm at 30 GHz is
- 3.7 degree
  - 0.5 degree
  - 1.1 degree
  - 1 degree
- 15  $T_r = r/(1+r^2+r^4)$
- $$\sum_{i=1}^{\infty} T_r =$$
- $\frac{1}{4}$
  - 1
  - None of the above
  - $\frac{1}{2}$
- 16 A man with  $n$  keys wants to open a lock. He tries his keys at random. The expected number of attempts for his success is (keys are replaced after every attempt)
- $n/2$
  - $n$
  - $\sqrt{n}$
  - None of the above
- 17 If a counter having 10 FFs is initially at 0, what count will it hold after 2060 pulses?
- 000 000 1100
  - 000 001 1100
  - 000 001 1000
  - 000 000 1110
- 18 A memory system of size 16 K bytes is required to be designed using memory chips which have 12 address lines and 4 data lines each. Then the number of such chips required to design the memory system is
- 2
  - 4
  - 8
  - 16
- 19 Consider the following program for 8085
- ```

XRA A
LXI B, 0007H
LOOP: DCX B
      INZ LOOP
    
```
- The loop will be executed
- 8 times
  - once
  - 7 times
  - infinite times

20. A certain JK FF has  $t_{pd} = 12$  ns. The largest MOD counter that can be constructed from such FFs and still operate up to 10 MHz is
- a) 16                                      b) 256                                      c) 8                                      d) 128
21. Convolution of  $x(t+5)$  with impulse function  $\delta(t-7)$  is equal to
- a)  $x(t-2)$                                       b)  $x(t+12)$   
 c)  $x(t-12)$                                       d)  $x(t+2)$
22. The purpose of a Cassegrain feed in a parabolic reflector antenna is to
- a) Achieve higher antenna gain  
 b) Reduce the antenna size  
 c) Reduce the beamwidth  
 ✓ d) Ease of locating the feed at convenient point
23. A transfer function  $G(s)$  has pole-zero plot as shown in the figure. Given that the steady state function gain is 2, the transfer function  $G(s)$  will be given by

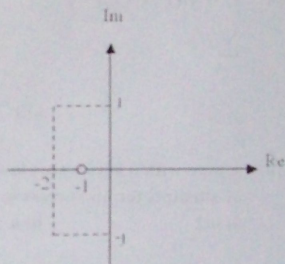

- a)  $\frac{5(s+1)}{s^2+4s+4}$                                       b)  $\frac{2(s+1)}{s^2+4s+5}$   
 c)  $\frac{10(s+1)}{s^2+4s+5}$                                       d)  $\frac{10(s+1)}{(s+2)^2}$
24. The impedance of a series RLC circuit is
- a)  $\sqrt{R^2 + X_L^2 + X_C^2}$                                       b)  $\sqrt{R^2 + X_L^2 - X_C^2}$   
 c)  $\sqrt{R^2 + (X_L - X_C)^2}$                                       d)  $\sqrt{R^2 + (X_L + X_C)^2}$
25. The advantage of  $\pi/4$  QPSK compared to conventional QPSK is ?
- ✓ a)  $\pi/4$  QPSK requires less bandwidth compared to conventional QPSK  
 b)  $\pi/4$  QPSK produces lower envelope variation compared to conventional QPSK  
 c)  $\pi/4$  QPSK receiver design is simple compared to conventional QPSK  
 d) There is no advantage

- 26 A moving coil iron ammeter may be compensated for frequency errors by
- Series inductance
  - Shunt resistance
  - Series resistor
  - Shunt capacitor

- 27 Find the value of  $V_o$  in the figure.

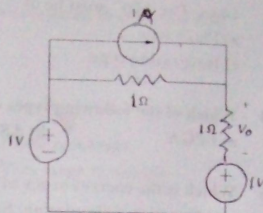

- 1/2 V
  - 1/2 V
  - 0 V
  - 3/2 V
- 28 What is the approximate skin depth in copper at 100 MHz?
- 0.1 micron
  - 10 microns
  - 10 mm
  - 100 mm
- 29 While designing a low noise amplifier, what is the importance of the noise resistance of a transistor?
- It gives the effective impedance offered by the input with respect to noise current
  - It defines the criterion for conjugate matching of input impedance
  - It tells us the resistance that would generate the same amount of noise at room temperature
  - It tells us how rapidly the noise figure increases as we move away from the optimum source impedance
- 30 Unattenuated radiation field at the surface of the earth of a quarter-wave monopole will exist if the earth surface is
- Lossy dielectric
  - Perfect insulator
  - Perfectly conducting
  - None of these

- 31 Given that

$$A = \begin{bmatrix} 1 & 0 & 0 \\ 0 & 2 & 0 \\ 0 & 0 & 3 \end{bmatrix}$$

Evaluate  $A^3 - 6A^2 + 11A - 10I$

- Null matrix
- Identity matrix
- 4I
- None of the above



- 32  $\lim_{x \rightarrow 0} x \log \sin(x)$  is  
a) 0                                          b)  $\frac{1}{2}$                                           c) 1                                          d) 2
- 33 A 12 bit ADC is operating with a 1  $\mu$ s clock period and the total conversion time is seen to be 14  $\mu$ s. The ADC must be of  
a) Flash type                                          b) Counting type  
c) Integrating type                                          d) Successive Approximation type
- 34 Which of the following types of devices is not field programmable?  
a) FPGA                                          b) ASIC                                          c) CPLD                                          d) PLD
- 35 Which is the correct order of different process steps for a typical FPGA design?  
a) Functional simulation, Synthesis, Place & Route, Timing Verification  
b) Functional simulation, Timing Verification, Synthesis, Place & Route  
c) Timing Verification, Synthesis, Functional simulation, Place & Route  
d) Synthesis, Functional simulation, Timing Verification, Place & Route
- 36 The theoretical dividing line between Reduced Instruction Set computing (RISC) microprocessor and Complex Instructions Set Computing (CISC) microprocessor is  
a) Instruction execution rate to be one instruction per clock cycle  
b) Number of address and data lines  
c) Number of pins in the chip  
d) None of the above
- 37 In a pulsed radar, the peak radar transmitter power is increased by a factor of 81 keeping all other radar parameters unchanged. The maximum range capability of the radar increases by a factor of  
a) 81                                          b) 9                                          c) 27                                          d) 3
- 38 A radar transmitter has a PRF of 1500 PPS and a pulse width of 1 micro second. Its duty cycle is  
a) 0.0075                                          b) 0.015                                          c) 0.0015                                          d) 0.00075
- 39 Which of the following technology results in least power dissipation?  
a) CMOS                                          b) ECL                                          c) TTL                                          d) NMOS
- 40 A power MOSFET is a  
a) Current controlled device                                          b) Frequency controlled device  
c) Voltage controlled device                                          d) None of the above

- 41 The advantage of differential PSK (DPSK) over coherent PSK is
- DPSK requires less bandwidth compared coherent PSK
  - DPSK receiver design is simple compared to coherent PSK
  - DPSK Bit Error rate is lower than coherent PSK
  - For same bandwidth, DPSK bit rate is higher compared to coherent PSK

- 42 An ideal current meter should have
- Zero resistance
  - Finite resistance
  - Infinite resistance
  - Very large resistance

- 43 For the network shown in the figure  $V_i(t)$  is the input and  $i(t)$  is the output. The transfer function

$$\frac{I(s)}{V_i(s)}$$

of the network is

- $\frac{C}{RCs^2 + LCs + 1}$
- $\frac{C}{LCs^2 + RCs + 1}$
- $\frac{Cs}{RCs^2 + LCs + 1}$
- $\frac{Cs}{LCs^2 + RCs + 1}$

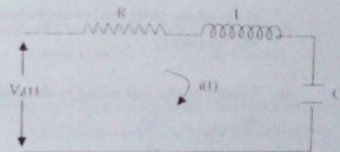

- 44 The length of a lossy shorted stub is  $1/32 \lambda$ . What will be the nature of its input impedance?
- A low inductive reactance in series with a low resistance
  - A low capacitive reactance in shunt with a high resistance
  - A high capacitive reactance in series with a low resistance
  - A high inductive reactance in series with a low resistance

- 45 Refer to the circuit in the figure. Which of the following statements is NOT true about this circuit?

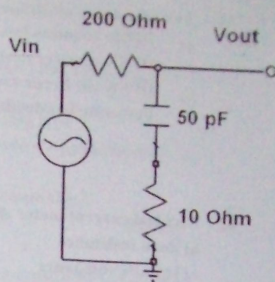

- a) It is a low pass filter
- b) It has a finite attenuation at infinite frequency
- c) Its phase shift varies monotonically with the frequency
- d) It has one pole and one zero
- 46 Which of the following is the correct continuity equation:
- a)  $\nabla \cdot J = \frac{\partial \rho}{\partial t}$
- b)  $\nabla \cdot J = -\frac{\partial \rho}{\partial t}$
- c)  $\nabla \cdot J = 0$
- d)  $\nabla \cdot J = -\frac{\partial E}{\partial t}$
- 47  $\alpha, \beta$  are the roots of the equation  $x^2 + x + 1 = 0$ . Then  $\alpha^{3n} + \beta^{3n}$  is
- a) 1
- b) 2
- c) 0
- d) 3
- 48 A point moving in the complex plane satisfies the following relation  $z^2 + z^{*2} = 8$ , where  $z^*$  stands for the complex conjugate of  $z$ . The difference of the distances of the moving point from  $(2\sqrt{2}, 0)$  and  $(-2\sqrt{2}, 0)$  is
- a) 8
- b) 2
- c) 4
- d) 6
- 49 The greatest negative number which can be stored in a computer that has 8-bit word length and uses 2's complement arithmetic is
- a) -256
- b) -255
- c) -128
- d) -127
- 50 Which of the following ADCs uses over sampling in its operation
- a) Sigma - delta ADC
- b) Counter ramp convertor
- c) Successive Approximation Register ADC
- d) Flash Converter



51. A mealy state machine's output depends on  
 a) State and outputs  
 b) Inputs  
 c) State  
 d) State and inputs
52. The characteristic equation of the T-FF is given by  
 a)  $Q^* = \bar{T}Q$   
 b)  $Q^* = T\bar{Q}$   
 c)  $Q^* = TQ$   
 d)  $Q^* = TQ + Q\bar{T}$
53. Percentage modulation of an AM wave having a power content of 8 KW at carrier frequency and 2 KW in each of its side bands is  
 a) 60 %  
 b) 70 %  
 c) 100 %  
 d) 80 %
54. Approximate equivalent noise temperature (deg. K) of an amplifier with a noise factor of 1.04 is  
 a) 301.6  
 b) 11.6  
 c) 278.4  
 d) 5.8
55. A differential amplifier is used in the input stage of Op-Amps to achieve very high  
 a) open-loop gain  
 b) bandwidth  
 c) slew rate  
 d) CMRR
56. Which two-port parameters are best suited for analyzing a series-shunt feedback circuit?  
 a) Z-Parameters  
 b) H-Parameters  
 c) Y-Parameters  
 d) S-Parameters
- 57.

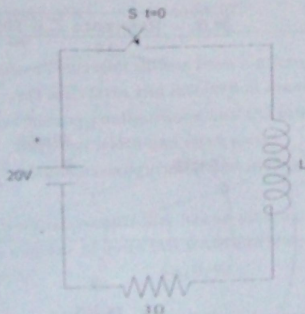

For the circuit shown in the figure, the switch is closed at  $t=0$ . After some time when the current in the inductor was 6A, the rate of change of current through the inductor was 4A/sec. The value of the inductor is

- a) 0.5 H  
 b) 1.5 H  
 c) 1.0 H  
 d) Indeterminate

*Handwritten notes:*  
 $i = \frac{V}{R} (1 - e^{-Rt/L})$   
 $6 = \frac{20}{3} (1 - e^{-Rt/L})$   
 $1 - e^{-Rt/L} = \frac{6 \times 3}{20} = \frac{18}{20} = \frac{9}{10}$   
 $e^{-Rt/L} = 1 - \frac{9}{10} = \frac{1}{10}$   
 $-\frac{Rt}{L} = \ln\left(\frac{1}{10}\right) = -\ln(10)$   
 $\frac{Rt}{L} = \ln(10)$   
 $\frac{3t}{L} = \ln(10)$   
 $L = \frac{3t}{\ln(10)}$

58

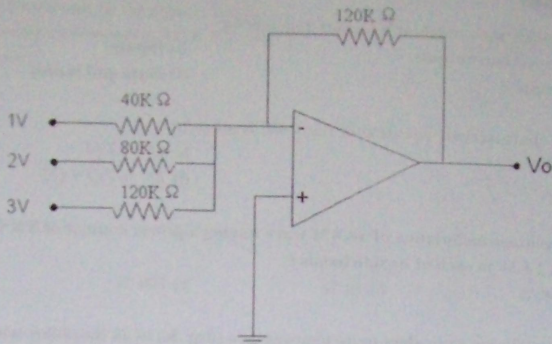

In the circuit shown in the above figure, the value of output  $V_o$  is

- a) +6V                      b) -9V                      c) -6V                      d) +9V

59 The characteristics equation of a closed loop control system is given as  $s^2 + 4s + 16 = 0$ . The resonant frequency in radian/sec of the system is

- a) 2                              b)  $2\sqrt{3}$                       c) 4                              d)  $2\sqrt{2}$

60 Which point in the Smith Chart is labeled with the WRONG impedance?

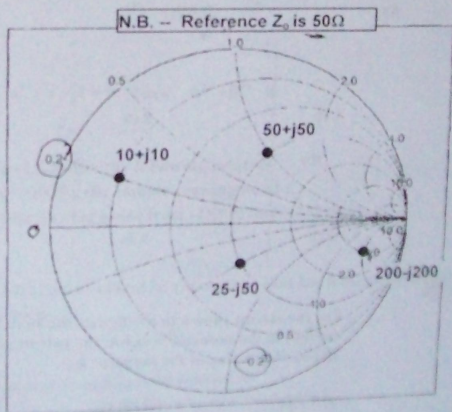

- a)  $10+j10$                       b)  $50+j50$                       c)  $200-j200$                       d)  $25-j50$

61. If a line is terminated in an open circuit, the VSWR is  
 a)  $\infty$                       b) 0                      c) 1                      d) -1
62. Unit of relative permeability is  
 a) Henry/meter              b) Henry                      c) Henry-meter              d) It is dimensionless
63.  $f(x) = [\tan^2 x]$   
 ( $[\ ]$  stands for greatest integer function)  
 a)  $f(x)$  continuous at  $x = 0$   
 b) limit  $f(x)$  does not exist as  $x$  tend to 0  
 c)  $f'(0) = 1$   
 d)  $f(x)$  not derivable at  $x = 0$
64. Number of real values of  $(a + ib)^{1/n} + (a - ib)^{1/n}$  is  
 a) 0                      b) 1                      c) n                      d) None of the above
65. A 5 bit DAC has a current output. For a digital input of 10100, an output current of 10 mA is produced. What will be the output current for a digital input of 11101?  
 a) 14.5 mA                      b) -10 mA                      c) -100 mA                      d) Not possible to calculate
66. The ethernet protocol uses  
 a) CSMA/CA                      b) SCPC                      c) CSMA/CD                      d) Slotted ALOHA
67. A micro controller differs from a microprocessor in terms of  
 a) I/O interfaces and instruction decoding  
 b) Memory configuration and I/O interfaces  
 c) Data bus width and clock speed  
 d) Memory configuration and instruction decoding
68. An 8-bit microcontroller has an external RAM with the memory map from 8000H to 9FFFH. The number of bytes this RAM can store is  
 a) 8193                      b) 8192                      c) 8191                      d) 8000
69. An audio frequency of 15 KHz is frequency modulated with a deviation of 75 KHz. The resulting bandwidth is  
 a) 180 KHz                      b) 150 KHz                      c) 210 KHz                      d) 240 KHz
70. A 1kW carrier is Amplitude Modulated to a depth of 60%. The total power in the modulated carrier is  
 a) 1 kW                      b) 1.06 kW                      c) 1.6 kW                      d) 1.18 kW

71

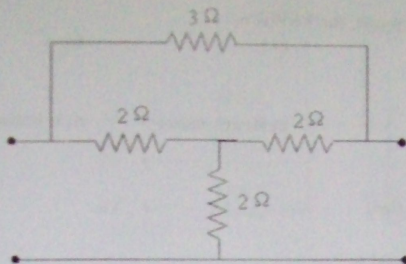

The  $Y_{21}$  parameter of the network shown in the given figure will be

- a)  $\frac{1}{6}$                       b)  $-\frac{1}{6}$                       c)  $\frac{1}{3}$                       d)  $-\frac{1}{3}$

72 An inductance of 1 H is realized using air core with 100 turns. What will be the inductance if the number of turns are doubled ?

- a) 1 H                      b) 0.5 H                      c) 2 H                      d) None of these

73 An inductor of inductance 0.1 H, carrying current of 6 Amps will store energy of

- a) 6 Joules                      b) 36 Joules                      c) 1.8 Joules                      d) 3.6 Joules

74 A coil has self resistance of  $5\Omega$  and inductance of  $1\mu\text{H}$ . The value of Q at 1 MHz frequency is

- a) 200                      b) 100                      c) 40                      d) None of these

75 The closed loop transfer function of a unity feedback control system is

$G(s) = \frac{1}{(s+2)^2}$ . The closed loop transfer function will have poles at

- a)  $-2, \pm j$                       b)  $-2, -1$                       c)  $-2, -2$                       d)  $-2, 2$

76 The dominant mode of propagation in microstrip line in low frequency approximation is

- a)  $\text{TM}_{11}$                        b) Quasi-TEM                       c) TEM                      d)  $\text{TE}_{01}$

77 Consider a transmission line of characteristic impedance 50 ohms and the line is terminated at one end by  $+j50$  ohms, the VSWR produced in the transmission line will be

- a) +1                      b) zero                      c) -1                      d) infinity

78 The divergence of magnetic flux density is

- a)  $j$                       b)  $\rho$                       c) 0                      d)  $\infty$

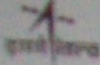

79. A straight line and a circle of radius  $a$  are given. A chord is drawn at random to this circle parallel to the given line. Expected length of the chord is
- a)  $2a$                       b)  $\pi a$                       c)  $\pi a/2$                       d) None of the above
80. There is a function  $f(x)$ , such that  $f(0) = 1$  and  $f'(0) = -1$  and  $f(x)$  is positive for all values of  $x$ . Then,
- a)  $f''(x) < 0$  for all  $x$   
b)  $-1 < f''(x) < 0$  for all  $x$   
c)  $-2 < f''(x) < -1$  for all  $x$   
d) None of the above

