

SATHYABAMA UNIVERSITY

(Established under section 3 of UGC Act, 1956)

Course & Branch: B.E – ECE/E&C/EIE/ETCE

Title of the paper: Solid State Circuits - I /Electronics Circuits I

Semester: III

Max. Marks: 80

Sub.Code: 418307/518307/517307/6C0035(2006/2007) Time: 3 Hours

Date: 05-11-2008

Session: FN

PART – A

(10 x 2 = 20)

Answer All the Questions

1. Define ripple factor.
2. What is voltage regulator?
3. What is the need of biasing circuits for BJT?
4. List the advantages of h parameter.
5. Draw the small signal equivalent circuit of JFET.
6. What is the difference between biasing circuits for depletion type MOSFET and JFET?
7. What is harmonic distortion?
8. Mention some applications of class C amplifiers.
9. State Miller theorem.
10. What is cascode amplifier?

PART – B

(5 x 12 = 60)

Answer All the Questions

11. Draw the circuit diagram for full wave rectifier with inductor filter. Explain its operation and also calculate its ripple factor.
(or)
12. (a) Describe the monolithic IC Regulators.
(b) Distinguish between shunt and series voltage regulators.

13. Draw the h parameter equivalent circuit for a typical CE amplifier and derive the expression for Input impedance, Output impedance, Voltage gain and Current gain.

(or)

14. (a) Name the various types of biasing circuits for BJT. (2)

(b) Explain any two Biasing Methods of BJT. (10)

15. (a) Describe the voltage divider bias for JFET (7)

(b) Find V_{DS} and V_{GS} for the circuit shown in fig. (5)

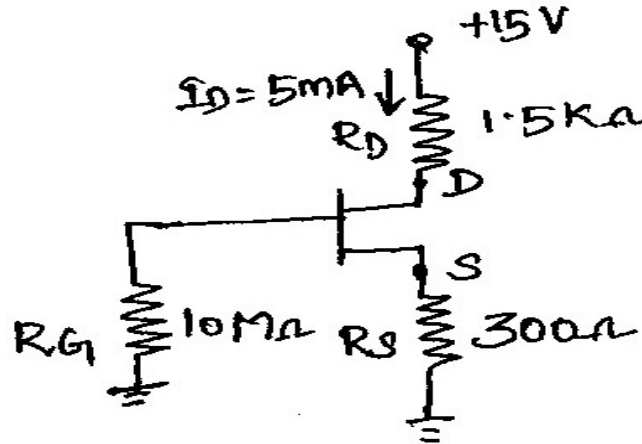

(or)

16. Explain the MOSFET biasing circuits.

17. Explain the working of class B amplifier and derive its efficiency.

(or)

18. (a) Explain the cross over distortion in class B amplifier. (4)

(b) With neat circuit diagram, explain the principle of operation of push pull amplifier circuit using transistor. (8)

19. Draw the circuit diagram of a darlington emitter follower and derive the expression for its voltage gain.

(or)

20. Explain the working of RC coupled amplifier and also draw the frequency response of the amplifier.