



Australian Government

Civil Aviation Safety Authority

TRAINING & EXAMINATION WORKBOOK
for
DAY VFR SYLLABUS
Version 3 - 01 July 2011

[formerly titled VFR (Day) Work Booklet]

The Civil Aviation Safety Authority (CASA) owns copyright of this workbook.

The workbook is only for use in training to the Day VFR aeronautical knowledge syllabus of training and the associated CASA PPL and CPL examinations, and not to be used for any other purpose.

After use in a CASA PPL or CPL examination, the workbook must not be removed from the examination room but left with the CASA CyberExams supervisor for destruction. Failure to comply with these instructions may give CASA grounds for taking action against the candidate under CAR 298A, which action could lead to the outcome indicated in CAR 298A (5).

TABLE OF CONTENTS

CONTENT	PAGE	CONTENT	PAGE
Company Policy	3	Figs 16 / 17 / 18: Navigation	31
Figs 1 / 2 : Aerodrome Markers/Markings	4	Figs 19 / 20 / 21: Navigation	32
Scribble pad	5	Figs 22 / 23 / 24: Navigation	33
Fig 3 - Take-off Weight Chart	6	Figs 25 / 26 / 27: Navigation	34
Fig 4 - Landing Distance Chart	7	Figs 28 / 29 / 29A: Navigation	35
Fig 5 - Take-off Weight Chart	8	Figs 30 / 31: Navigation	36
Fig 6 - Landing Chart	9	Figs 32 / 33 / 34: Navigation	37
Loading System Alpha: Instructions	10	Figs 35 / 36 / 37: Navigation	38
Fig 7 - Loading System Alpha	11	Figs 38 / 39: Navigation	39
Loading System Bravo: Instructions	12	Figs 40 / 41 / 42 / 43: Principles of Flight	40
Fig 8 - Loading System Bravo	13	Scribble pad	41
Loading System Charlie: Instructions	14	Scribble pad	42
Loading System Charlie: Index Units	15	Scribble pad	43
Fig 9 - Loading System Charlie	16	Figs 48 / 49 Meteorology	44
Scribble pad	17	MSL Analysis charts	
Loading System Echo: Instructions	18	Meteorology – ARFOR No. 1	45
Loading System Echo: Instructions	19	Meteorology – ARFOR No. 2	46
(Continued)		Meteorology – ARFOR No. 3	47
Fig 10 - Loading System Echo: Index Units	20	Meteorology – ARFOR No. 4	48
Fig 11 - Loading System Echo:	21	Meteorology – ARFOR No. 5	49
CG Envelope		Meteorology – ARFOR No. 6	50
Fig 12 - Take-off Weight Chart:	22	Scribble pad	51
Aircraft Echo		Scribble pad	52
Fig 13 - Landing Weight Chart:	23	Scribble pad	53
Aircraft Echo		Meteorology - PCA	54
Helicopter Figures “A” and “B”	24	ARFOR Boundaries for Flights	
Helicopter Figures “C” and “D”	25	Scribble pad	55
Helicopter Figures “E” and “F”	26	Scribble pad	56
WAC Extract: (3219) TOWNSVILLE	27		
WAC Extract: (3456) SYDNEY	28 & 29		
WAC Extract: (3356) BOURKE	30		

Pages 27 to 30, WAC Extracts.

This work contains aeronautical information and data which is © Airservices Australia 2011. No part of this work may be reproduced in any form or by any means without the prior written consent of Airservices Australia. Airservices Australia does not guarantee that the aeronautical information and data is current or free from errors, and disclaims all warranties in relation to its quality, performance or suitability for any purpose. Not for operational use. All rights reserved.

EXTRACT FROM COMPANY OPERATIONS MANUAL

Fuel Reserves

Fuel Reserves (for all flights) shall be carried in accordance with Civil Aviation Advisory Publication, **CAAP 234-1 (1) dated November 2006.**

Aeroplane Landing Areas

Selection of and operation into landing areas other than licensed aerodromes, shall be in accordance with Civil Aviation Advisory Publication, **CAAP 92-1 (1) dated July 1992.**

Helicopter Landing Sites

Selection of and operations into helicopter landing sites (HLS), which are not licensed aerodromes, shall be in accordance with the Civil Aviation Advisory Publication, **CAAP 92-2 (1) dated January 1996.**

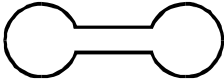
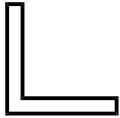
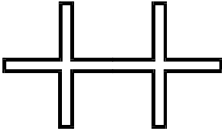

**AERODROME
MARKERS**

Figure 1

- (i) 
- (ii) 
- (iii) 
- (iv) 

**AERODROME
MARKINGS**

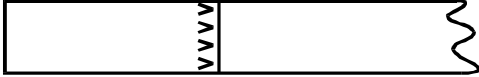
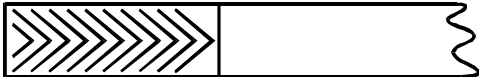
Figure 2

- (i)  (i)
- (ii)  (ii)
- (iii)  (iii)
- (iv)  (iv)

TAKE-OFF WEIGHT CHART

Figure 3

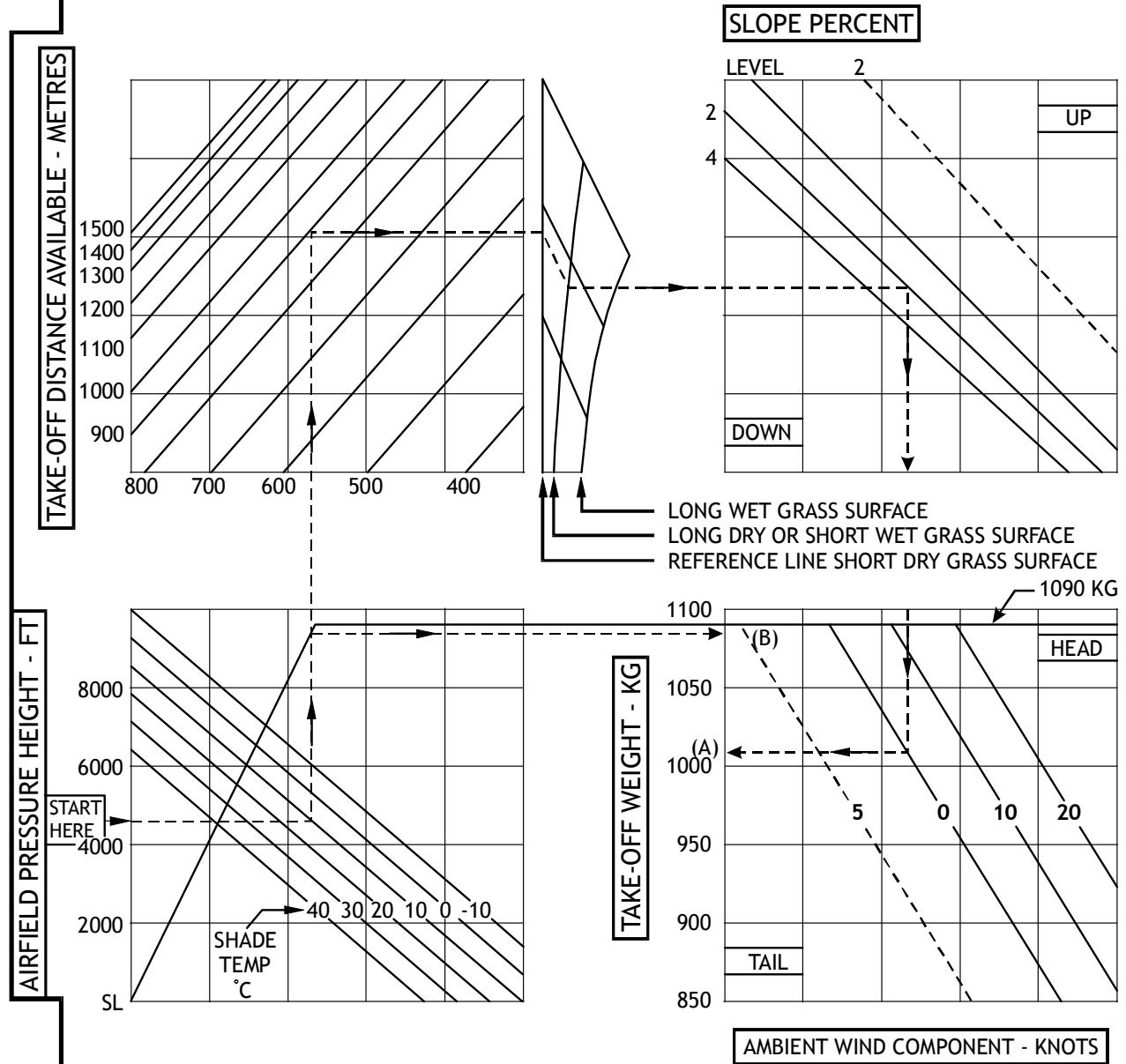

NOTES:

- (1) THE GROSS WEIGHT AT TAKE-OFF SHALL NOT EXCEED THE LESSOR OF (A) AND (B).
- (2) THE MAXIMUM TAKE-OFF WEIGHT = 1090 KG

POWER TO BE USED	FULL THROTTLE
FLAP SETTING	10 DEGREES
TAKE-OFF SAFETY SPEED	60 KIAS
TAKE-OFF DISTANCE FACTOR	1.15

LANDING DISTANCE CHART

Figure 4

FLAP SETTING 40 DEGREES
 APPROACH SPEED 65 KT IAS
 LANDING DISTANCE FACTOR 1.15

NOTE:
 LANDING DISTANCE REQUIRED
 IS INDEPENDENT OF LANDING
 WEIGHT.

NOTE:
 LANDING WEIGHT MUST
 NOT EXCEED CLIMB
 WEIGHT LIMIT BELOW

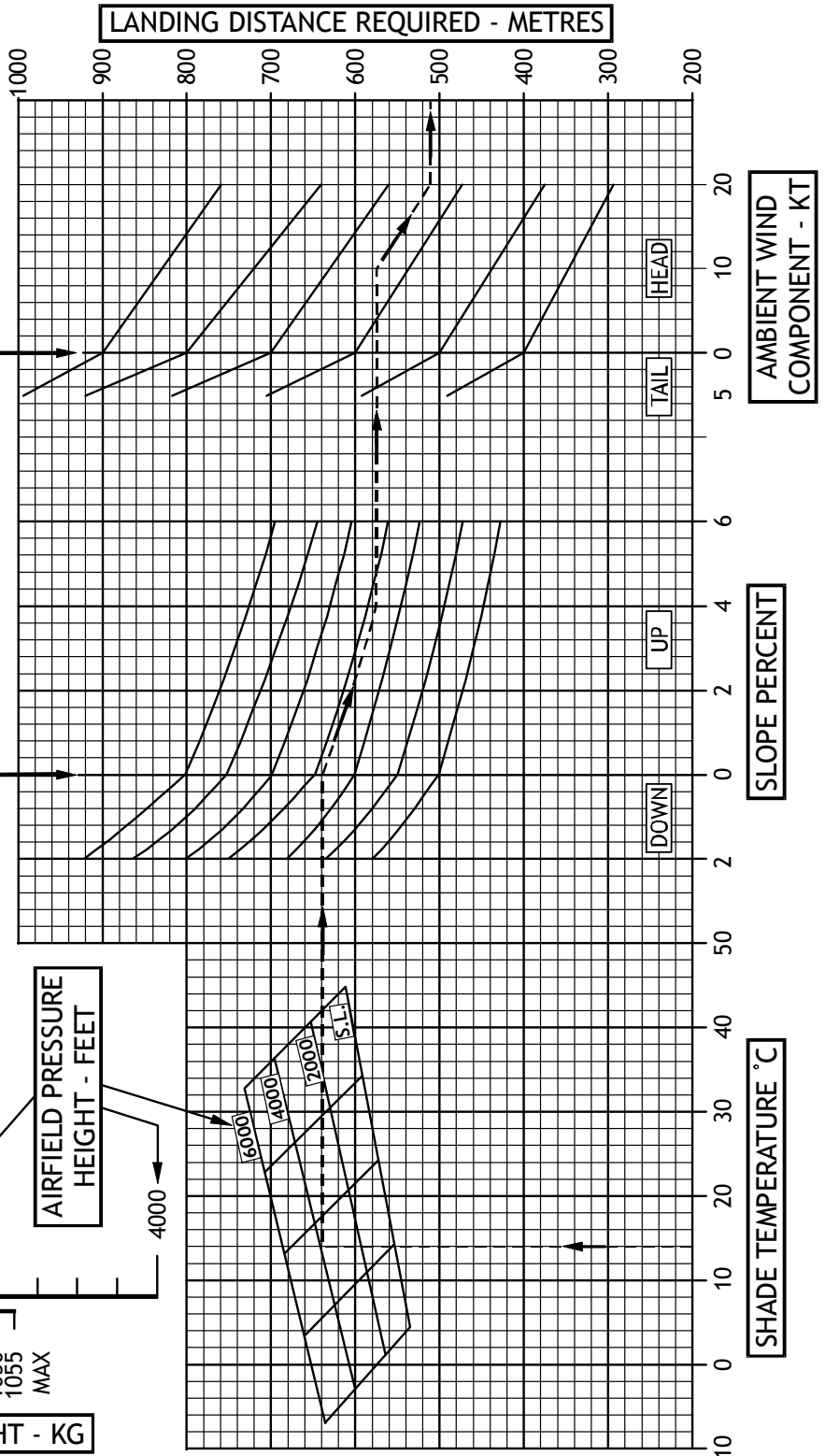
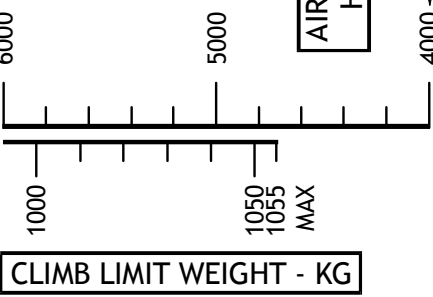

AMBIENT WIND
 COMPONENT - KT

SLOPE PERCENT

SHADE TEMPERATURE °C

TAKE-OFF WEIGHT CHART

Figure 5

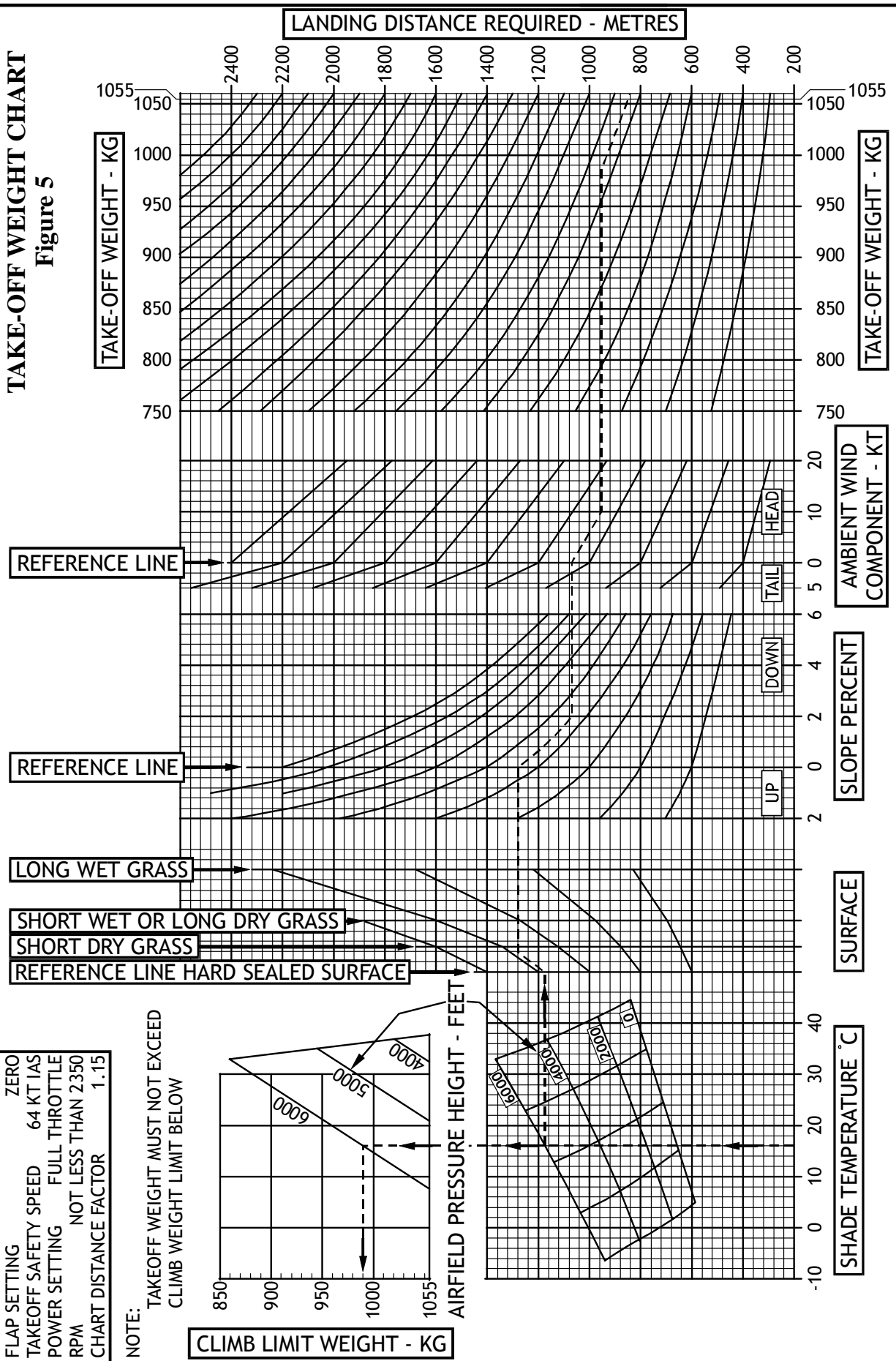

FLAP SETTING ZERO
 TAKEOFF SAFETY SPEED 64 KT IAS
 POWER SETTING FULL THROTTLE
 RPM NOT LESS THAN 2350
 CHART DISTANCE FACTOR 1.15

NOTE:
 TAKEOFF WEIGHT MUST NOT EXCEED
 CLIMB WEIGHT LIMIT BELOW

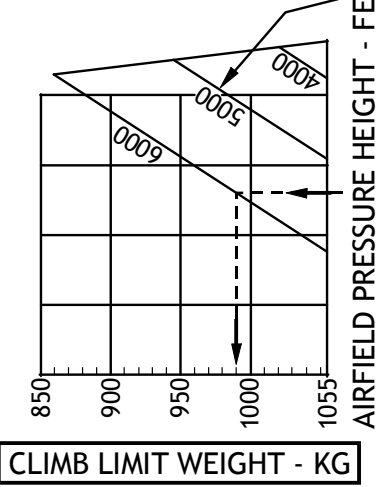

LANDING CHART

Figure 6

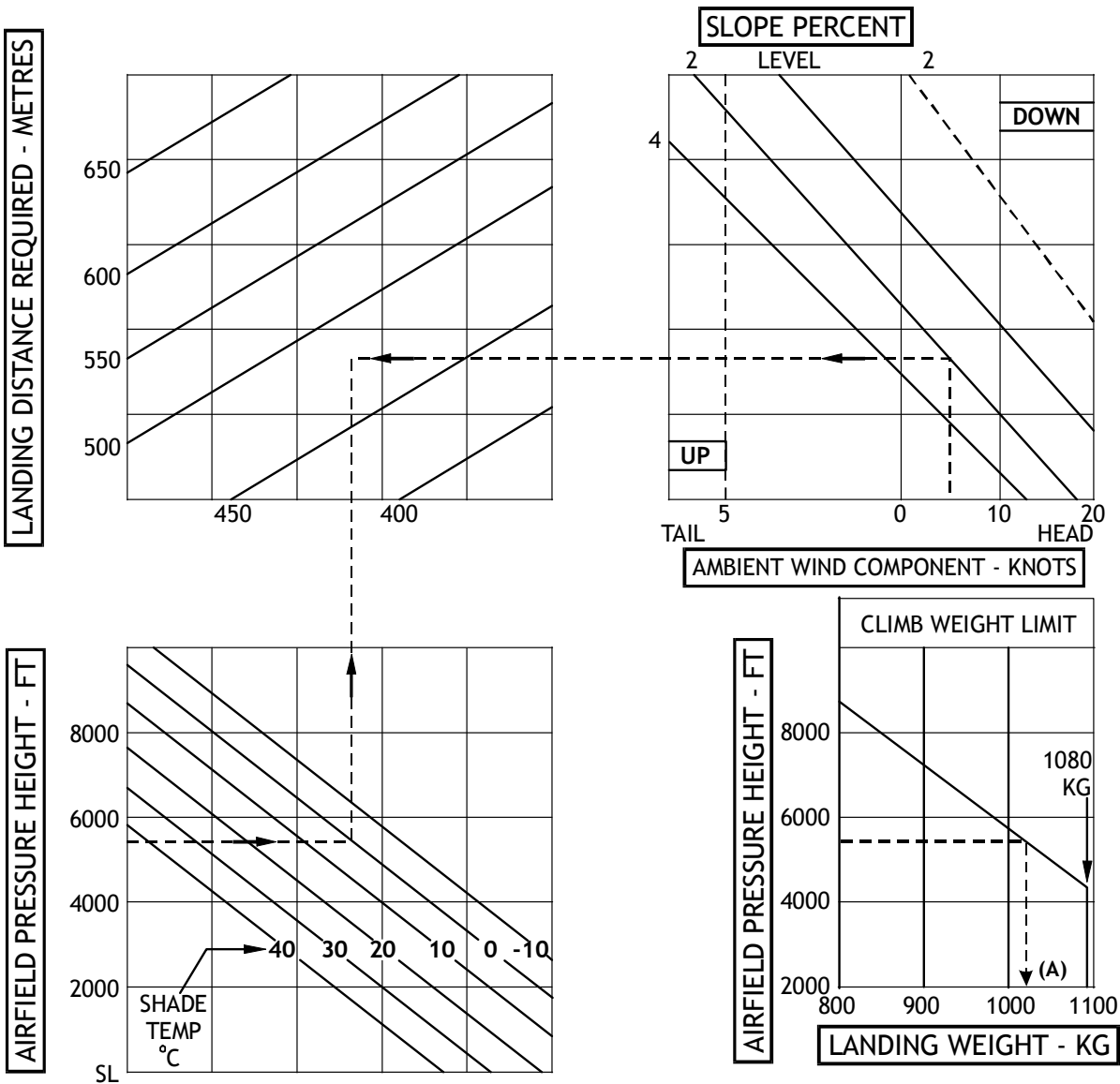

NOTES:

- (1) THE GROSS WEIGHT AT LANDING SHALL NOT EXCEED (A).
- (2) LANDING DISTANCE REQUIRED DOES NOT VARY SIGNIFICANTLY WITH WEIGHT

FLAP SETTING	30 DEGREES
APPROACH SPEED	58 KIAS
LANDING DISTANCE FACTOR	1.15

LOADING SYSTEM ALPHA
CONFIGURATION: 6/7 SEATS

INSTRUCTIONS FOR USE OF LOADING SYSTEM

- 1 Obtain Basic Empty Weight and Index Units from current Section of 6.2 of Flight Manual.
- 2 Mark Basic Empty Weight Index Units on top scale. Enter Basic Empty Weight at top of right-hand column.
- 3 Enter weights of load items required for flight in appropriate squares of right-hand column. Maximum weights for load items are indicated on Index Unit scales.
- 4 Total weights in right-hand column to obtain Zero Fuel Weight and Take-Off Weight. **
- 5 Draw horizontal lines on CG Envelope graph corresponding to Zero Fuel Weight and Take-Off Weight.
- 6 Draw a line vertically down from point marked on Basic Empty Weight Index Units scale to first load item scale.
* Move to the left or right on this load item index scale as per arrow directions, and mark point as appropriate to the load indicated in the right-hand column.
(e.g. 154 KG load @ 77 KG/div. = 2 div.).
- 7 Draw a line vertically down from the point marked on the first load item index scale to the second load item index scale and continue as per * above. Continue down the scales to “Rear Baggage”. Draw a line vertically from the “Rear Baggage” point down to intersect the Zero Fuel Weight line and Take-Off Weight line previously marked on the CG envelope graph.
- 8 The two intersection points as per 7, above must not exceed the boundaries of the CG envelope graph. If they do, re-organise the load in the aircraft and start again with steps 3 to 7.

**** DO NOT EXCEED MAXIMUM TAKE-OFF WEIGHT AS SHOWN ON CG ENVELOPE DIAGRAM OF THIS LOADING SYSTEM.**

EXAMPLE:

Basic Empty Weight	1050 KG
Empty Index units	-260
Row 1	150 KG (2 persons)
Row 2 (forward facing)	160 KG (2 persons)
Row 3	120 KG (2 persons)
Nose baggage	40 KG ----- Zero Fuel Wt = 1520 KG
Rear baggage	Nil
Fuel	113 KG ----- Take-Off Wt = 1633 KG

Note: Basic Empty Weight includes unusable fuel and full oil.

LOADING SYSTEM ALPHA

Figure 7

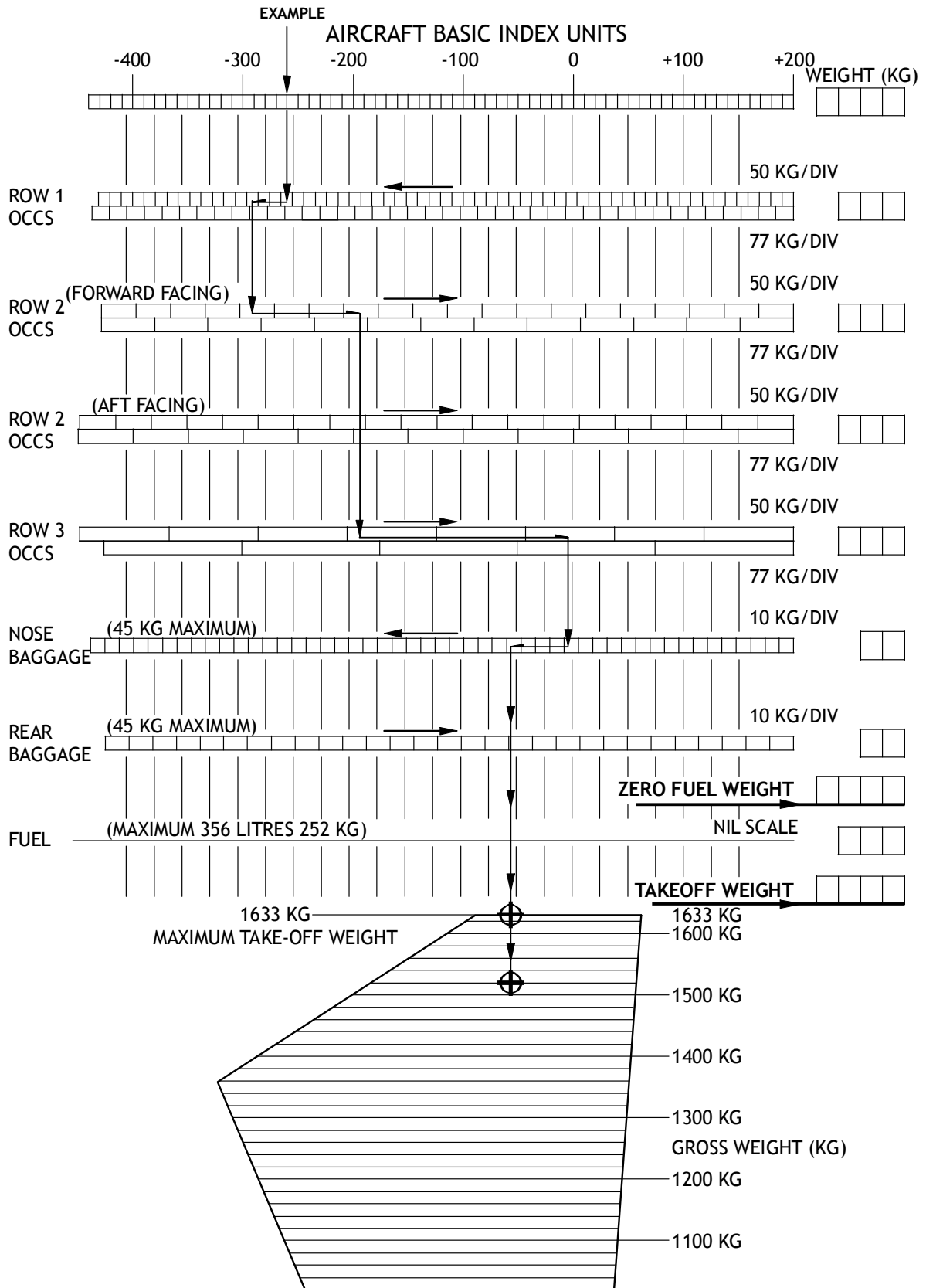

LOADING SYSTEM BRAVO
CONFIGURATION: 4 SEATS

INSTRUCTIONS FOR USE OF LOADING SYSTEM

To check the loading of the aircraft before take-off, calculate the total weight and total moments as shown in the example below.

Plot the total weight and moment on the “Centre of Gravity Envelope” chart, and if the intersection point is within the envelope, the loading is acceptable.

AIRCRAFT LIMITATIONS

Maximum take-off weight

Normal category: 1000 KG / 2200 lbs

Utility category: 841 KG / 1850 lbs

Maximum baggage compartment baggage: 53 KG / 120 lbs

Notes:

- 1 The aircraft is fitted with standard tanks (37 US Gallons at 6 lbs / gallon)
- 2 Empty weight includes unusable fuel and undrainable oil
- 3 Obtain Moment / 1000 inch pounds from the loading graph

EXAMPLE:

	WEIGHT (LBS)	ARM (IN)	MOMENT/1000 IN LB
Empty weight	1260	80	100.80
Oil	15	32	.48
Fuel (141 litres)	222	91	20.02
Pilot & Co-Pilot	320	91	29.12
Rear seat passengers	350	126	44.10
Baggage	25	151	3.78
Take-Off Weight	2192		198.30

Check CG is within the envelope

LOADING SYSTEM BRAVO

Figure 8

Add weight of items to be carried to aeroplane licensed empty weight. Add moment/1000 of items to be carried to total aeroplane moment/1000. Use Centre of Gravity Envelope to determine acceptability.

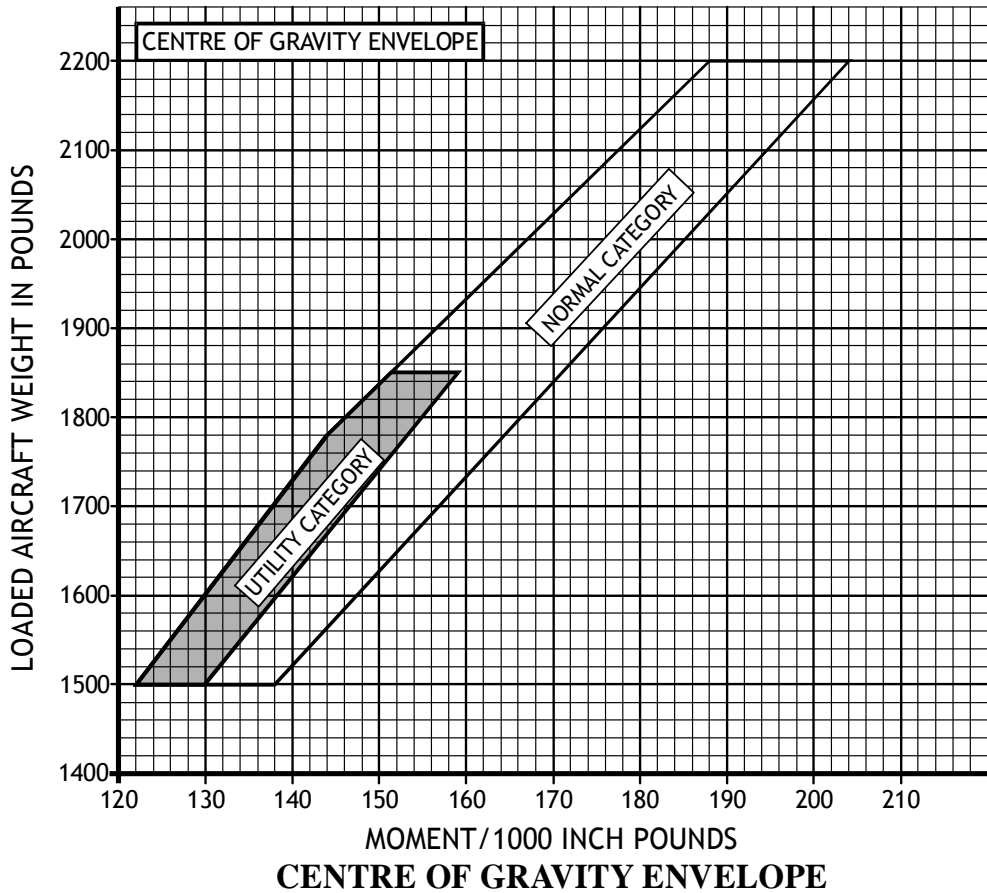
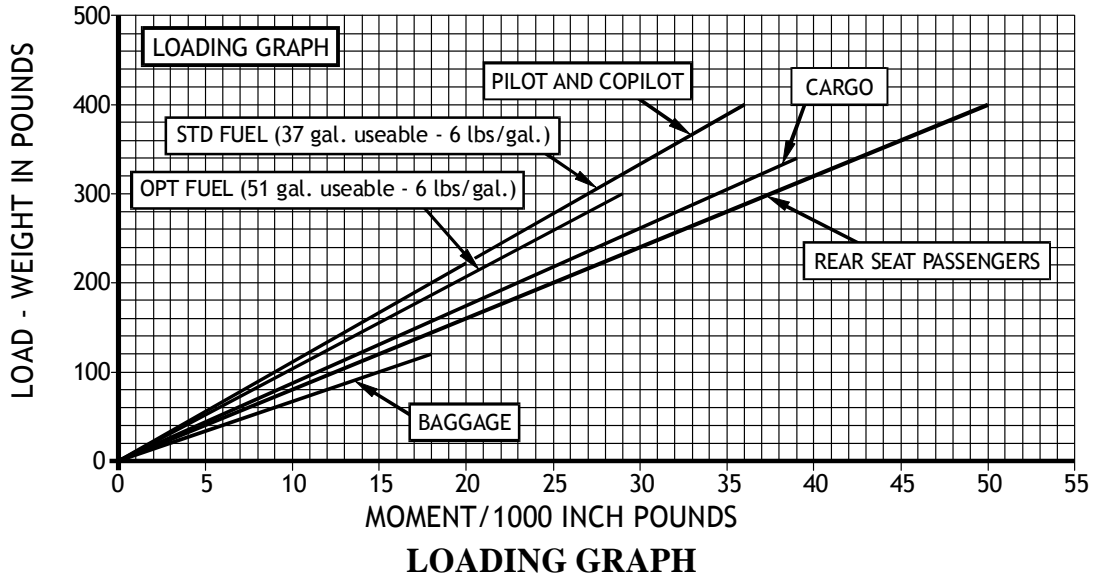

LOADING SYSTEM CHARLIE
CONFIGURATION: 4 SEATS

INSTRUCTIONS FOR USE OF LOADING SYSTEM

To check the loading of the aircraft before take-off, carry out a summation of weight and index units as shown in the example below. Check the centre of gravity of the aircraft at Zero Fuel Weight and Take-Off Weight by use of the formula:

$$\text{CG (mm aft of datum)} = \frac{\text{Index unit} \times 100}{\text{Weight}}$$

The CG must be within the envelope given at all times.

AIRCRAFT LIMITATIONS

Maximum take-off weight	
Normal category:	1115 KG
Utility category:	925 KG
Maximum baggage compartment baggage:	122 KG

Notes:

- 1 Aircraft empty weight includes unusable fuel and undrainable oil
- 2 All arms are in mm aft of datum
- 3 1 index unit = 100 KG mm

EXAMPLE:

	KG	IU
Aircraft empty weight	687	19,522
Full oil	7	86
1 pilot + 1 passenger Row 1	140	3,850
2 passengers Row 2	160	5,760
Baggage	20	842
Zero Fuel Weight	1014	30,060
Fuel 140 litres	99	2,920
Take-off Weight	1113	32,980

- CG check
1. At Zero Fuel Weight = $(30,060 \times 100) / 1014 = 2965 \text{ mm OK}$
 2. At Take-Off Weight = $(32,980 \times 100) / 1113 = 2963 \text{ mm OK}$

LOADING SYSTEM CHARLIE

INDEX UNITS

<u>Fuel</u>	ARM: 2950		<u>BAGGAGE</u>		ARM: 4210
20	14	413	10		421
40	28	826	20		842
60	43	1,268	30		1,263
80	57	1,682	40		1,684
100	71	2,095	50		2,105
120	85	2,507	60		2,526
140	99	2,920	70		2,947
160	114	3,363	80		3,368
180	129	3,806	90		3,789
200	142	4,189	100		4,210
216	153	4,513	110		4,631
			122		5,136

OCCUPANTS

KG	ROW 1	ROW 2
	ARM: 2750	ARM: 3600
40	1,100	1,440
45	1,237	1,620
50	1,375	1,800
55	1,512	1,980
60	1,650	2,160
65	1,786	2,340
70	1,925	2,520
75	2,062	2,700
80	2,200	2,880
85	2,338	3,060
90	2,475	3,240

OIL ARM : 1230

US Quarts	LITRES	KG	INDEX UNITS
6	5.7	5.0	62
7	6.6	6.0	74
8	7.6	7.0	86

LOADING SYSTEM CHARLIE
Figure 9

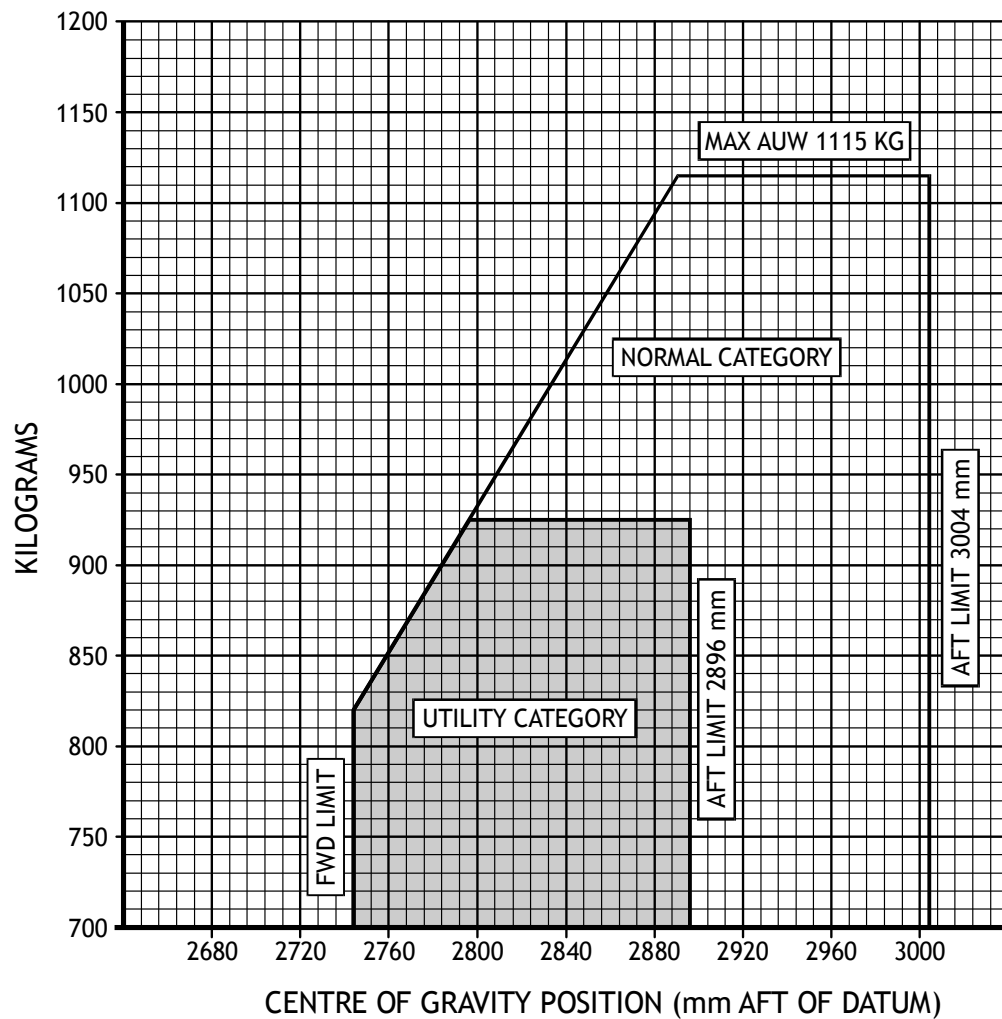

ALLOWABLE CENTRE OF GRAVITY ENVELOPE

CONVERSION FACTORS

1 inch = 25.4 mm

1 foot = 0.305 metre

1 lb = 0.454 KG

1 Imp gal = 1.201 US gal = 4.546 litres

100/130 aviation gasoline: Specific Gravity = 0.71

LOADING SYSTEM ECHO
CONFIGURATION: 6 SEATS

INSTRUCTIONS FOR USE OF LOADING SYSTEM

- 1 Moment Index chart (fig 10, page 20) may be used to determine the balance of the aeroplane. Locate the weight (in KG) of a particular load item on the vertical scale and move horizontally to the line representing the location of that item. From that point drop vertically to read off the Moment Index for that item.
- 2 Obtain the aeroplane basic empty weight and index units from the examination question. Add up the required total weight (Gross Weight) of the aeroplane and the corresponding Total Moment Index.
- 3 Refer to the Centre of Gravity chart (fig 11, page 21). Locate the Gross Weight of the loaded aeroplane (in KG) on the vertical scale and move horizontally to meet the vertical line representing the Total Moment Index of the loaded aeroplane. If the point of intersection, which represents the Centre of Gravity, falls in the shaded area, the aeroplane is correctly loaded.

Note: The Centre of Gravity must lie in the shaded area at ALL stages of flight.

Weight Limitations:	Maximum Take-off Weight	2950 KG
	Maximum Landing Weight	2725 KG
	Maximum Zero Fuel Weight	2630 KG

Balance Data:	The Mean Aerodynamic Chord (MAC) data is as follows:	
	Length of chord	1900 mm
	Location of leading edge	2190 mm aft of datum

Centre of Gravity range is as follows:
 2400 mm to 2680 mm at 2360 KG or less
 2560 mm to 2680 mm at 2950 KG
 Linear variation between the points given

Loading Data:

<u>Location</u>	<u>Maximum Permissible Load</u>	<u>Load Arm (mm Aft of Datum)</u>
Seating:		
Row 1 (Seats 1 & 2)	Pilot + 1 Passenger	2290
Row 2 (Seats 3 & 4)	2 Passengers	3300
Row 3 (Seats 5 & 7)	2 Passengers	4300
Cargo & Baggage Compts:		
Forward Compt	55 KG	500
Left wing Compt.	55 KG	3550
Right wing Compt.	55 KG	3550
Rear Compartment	155 KG	5000
Floor loading intensity	(All Compts) 450 KG/m ²	
Fuel:		
Left main tank	50 gal	1780
Right main tank	50 gal	1780
Left auxiliary tank	40 gal	2800
Right auxiliary tank	40 gal	2800

LOADING SYSTEM ECHO (continued)

Note: All passenger seats weigh 5 KG each and may be removed to permit the carriage of additional cargo or baggage in the cabin.

The maximum permissible load in the area otherwise occupied by a passenger seat is 82 KG.

If a passenger seat is removed, adjust the empty weight and empty moment.

EXAMPLE:

	WEIGHT (KG)	MOMENT INDEX (Refer to Figure 10)
Aeroplane Basic Empty Weight	1970	478.0
Row 1 (2 passengers)	150	34.0
Row 2 (2 passengers)	140	46.3
Row 3 (2 passengers)	130	56.0
Rear compartment	100	50.0
Zero Fuel Weight	2490	664.3
Fuel in Main tanks	200	35.5
Take-off Weight	2690	699.8
Fuel Burn-off	80	14.3
Landing Weight	2610	685.5

Refer to the Centre of Gravity Chart (Fig 11, page 21) to assess whether the horizontal line from the “Gross Weight” in question intersects the vertical line from its corresponding Total Moment Index in the shaded area.

LOADING SYSTEM ECHO
Figure 10

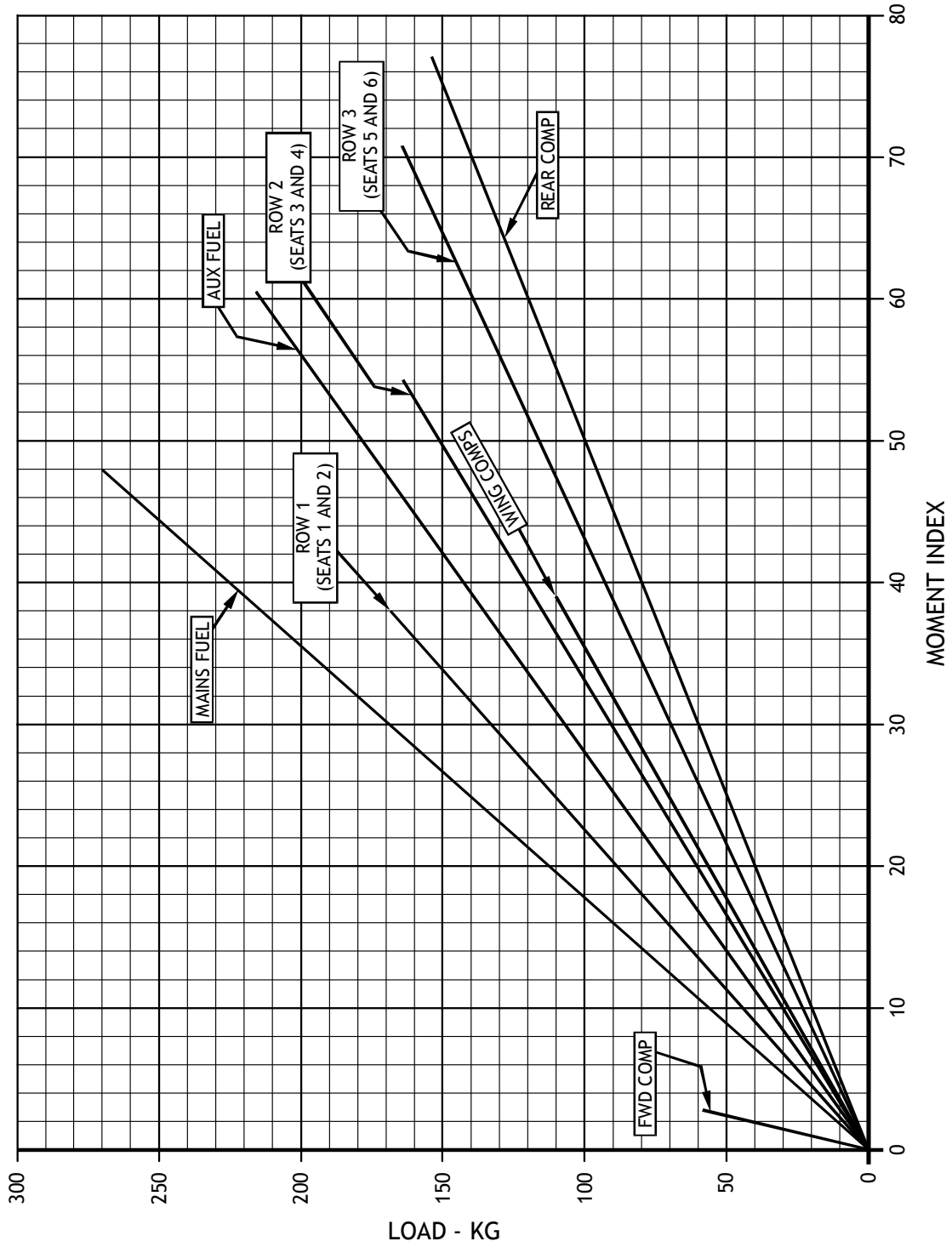

LOADING SYSTEM ECHO

Figure 11

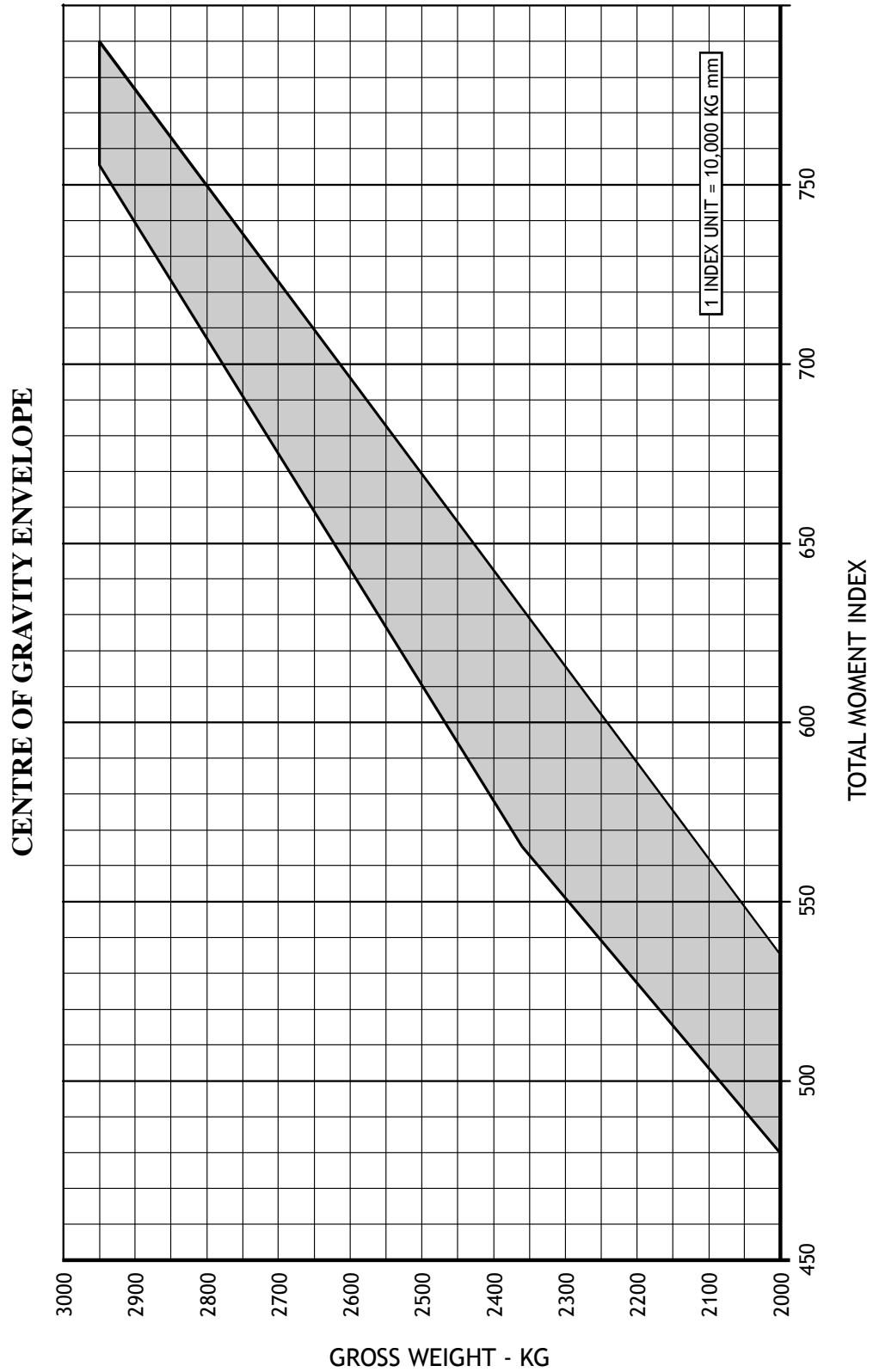

FLAP SETTING ZERO DEGREES
 TAKE-OFF SAFETY SPEED SEE SCALE
 DISTANCE FACTOR 1.22
 POWER TO BE USED RPM 3200 RPM
 MAN PRESS 37.4 IN Hg

TAKE-OFF WEIGHT CHART
AIRCRAFT - ECHO Figure 12

TAKE-OFF SAFETY SPEED
 KNOTS - IAS

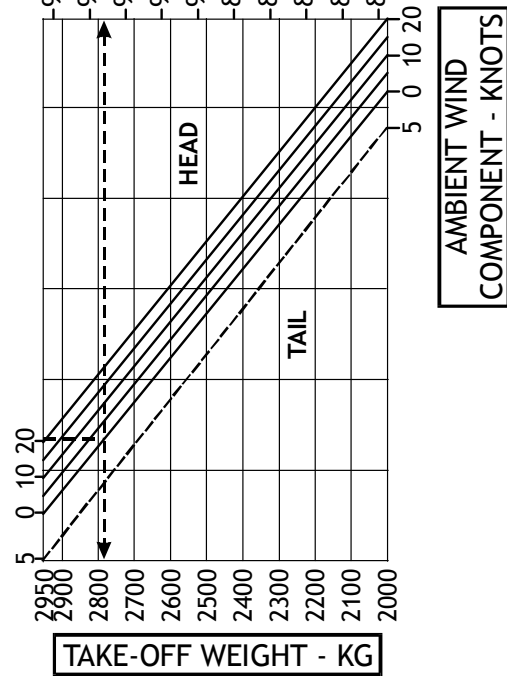
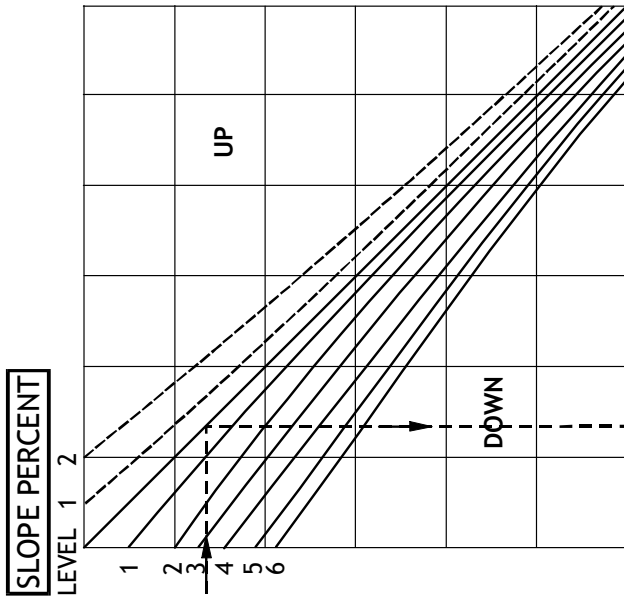

SURFACE

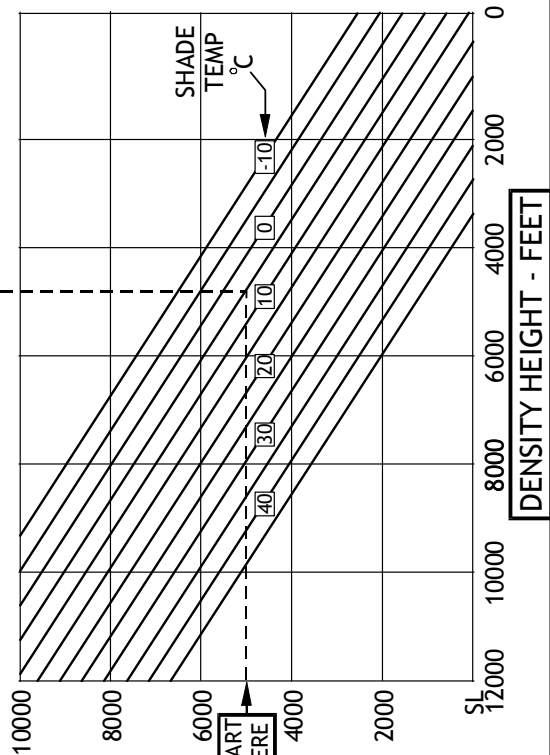
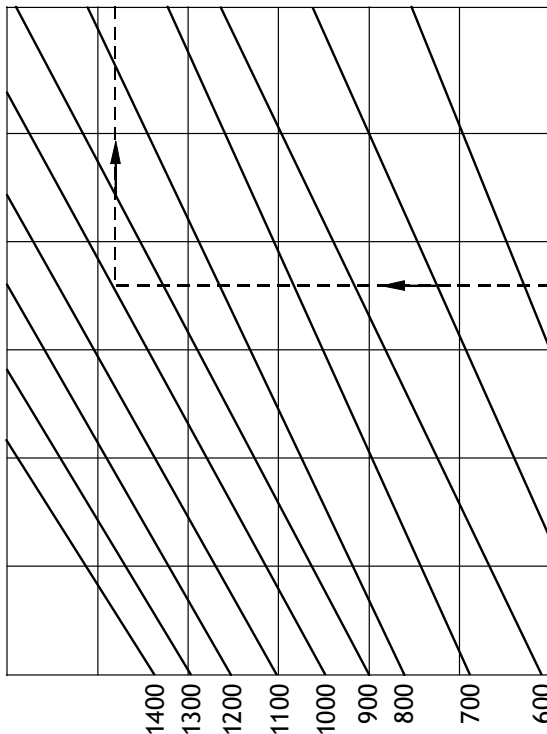
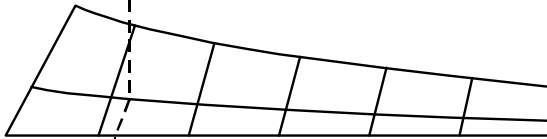

TAKE-OFF DISTANCE AVAILABLE - METRES

AIRFIELD PRESSURE HEIGHT - FEET

LANDING WEIGHT CHART AIRCRAFT - ECHO

Figure 13

FLAP SETTING	45 DEGREES
APPROACH SPEED	SEE SCALE
DISTANCE FACTOR	1.26

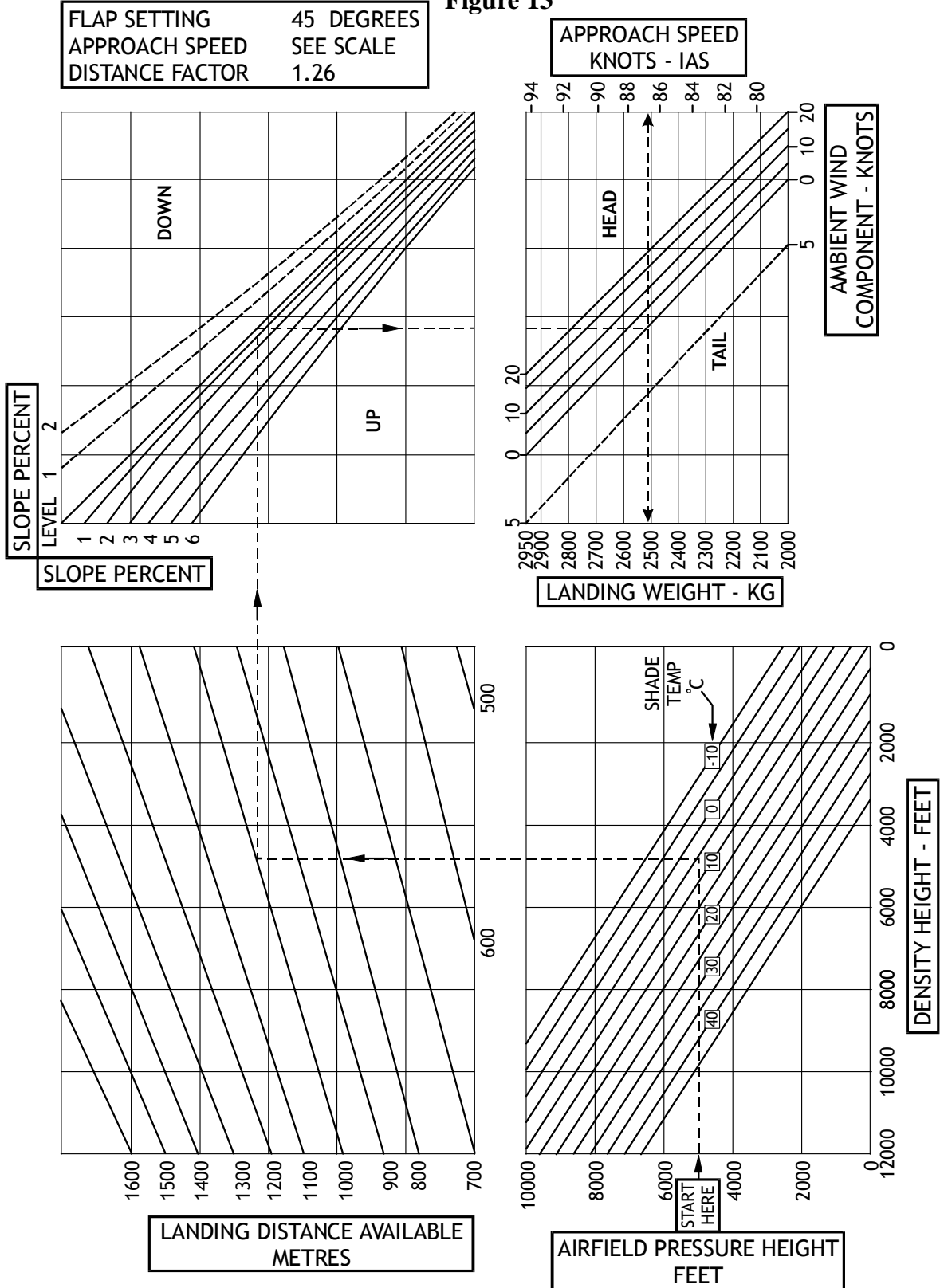

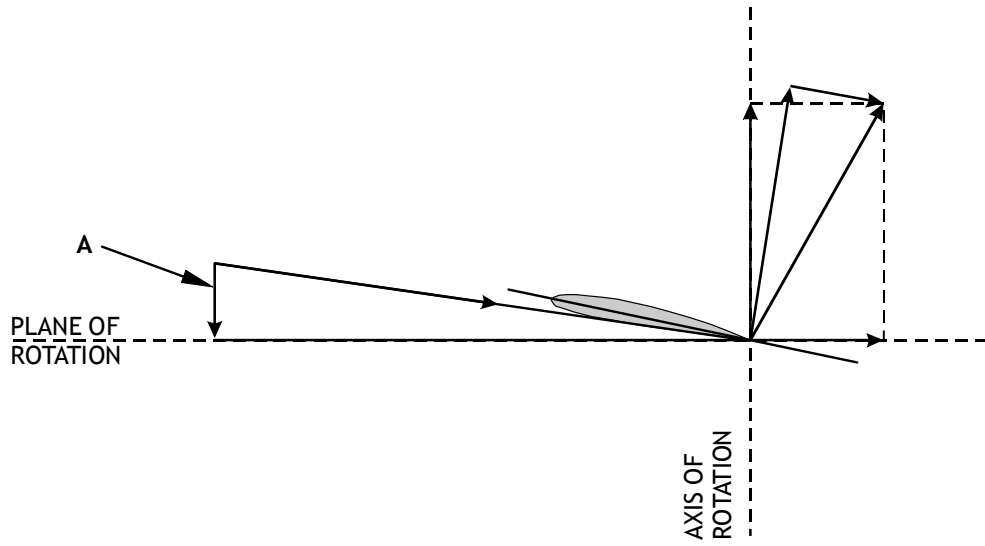

Helicopter Figure "A"

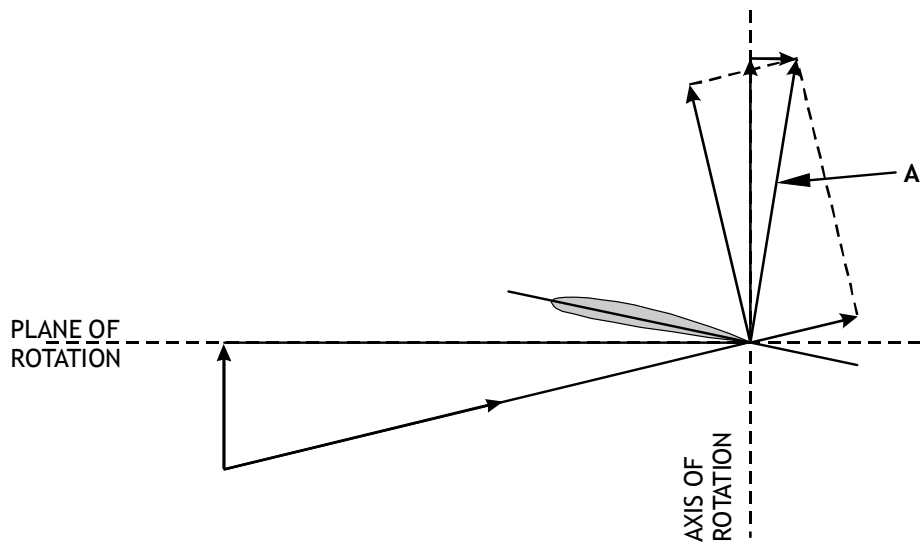

Helicopter Figure "B"

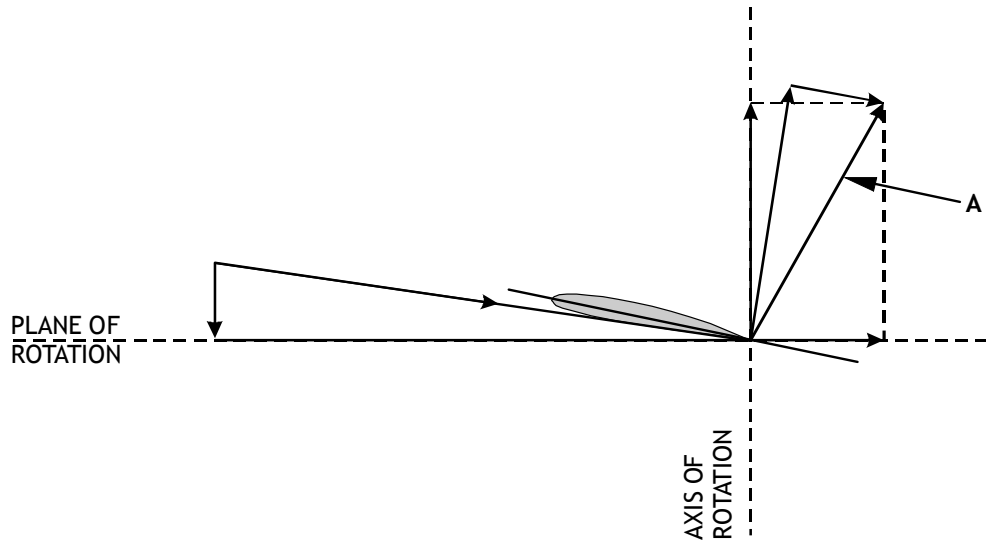

Helicopter Figure "C"

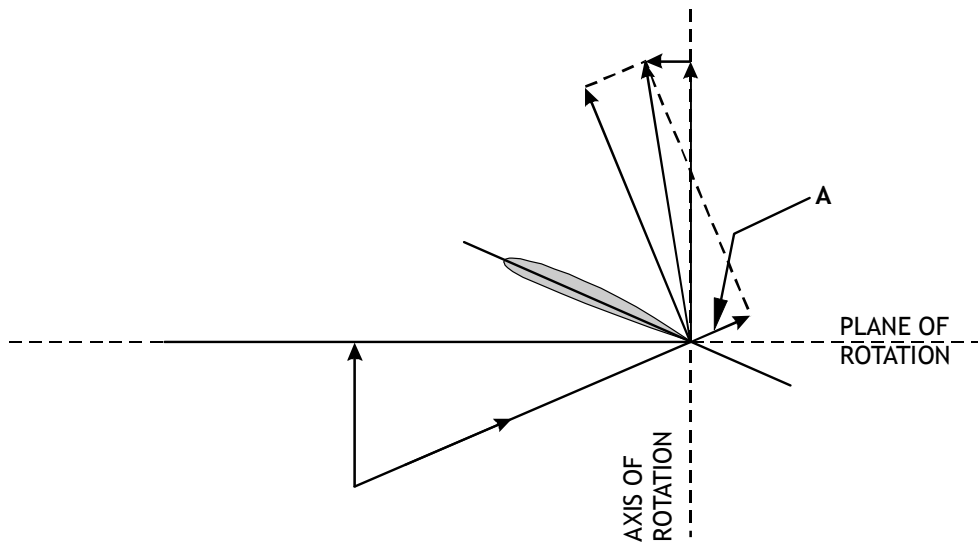

Helicopter Figure "D"

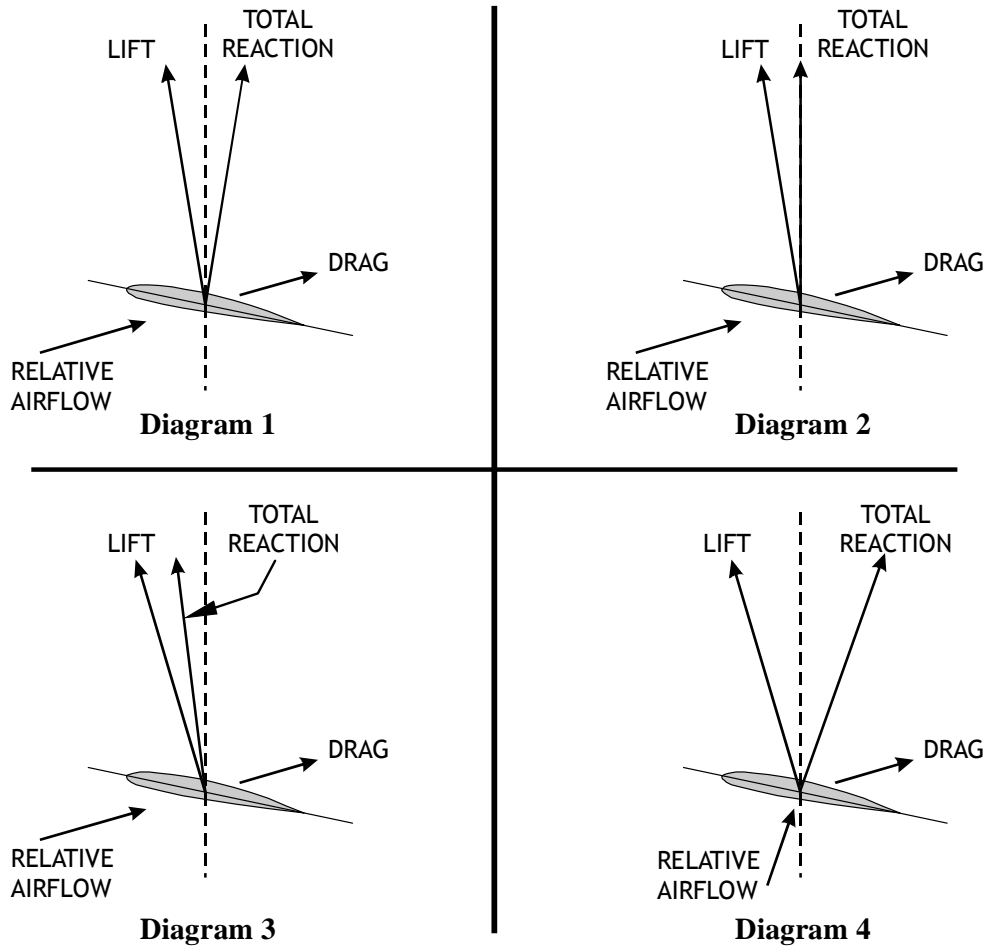

Helicopter Figure "E"

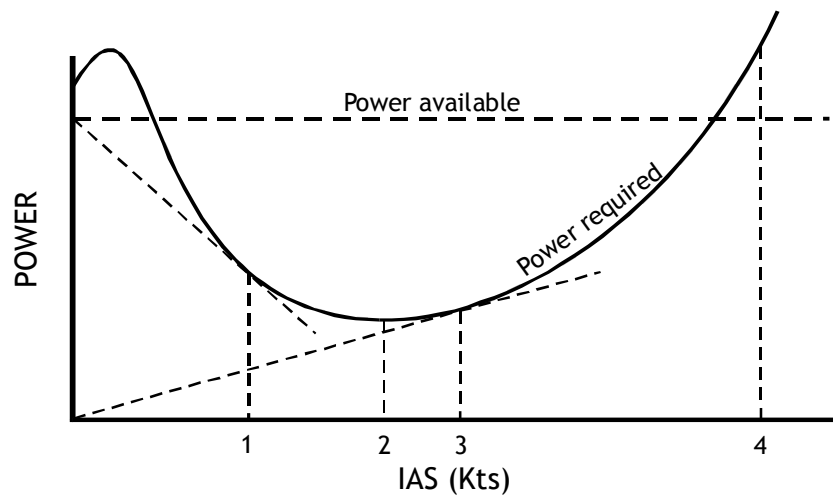

Helicopter Figure "F"

TOWNSVILLE (3219) WAC EXTRACT - 27

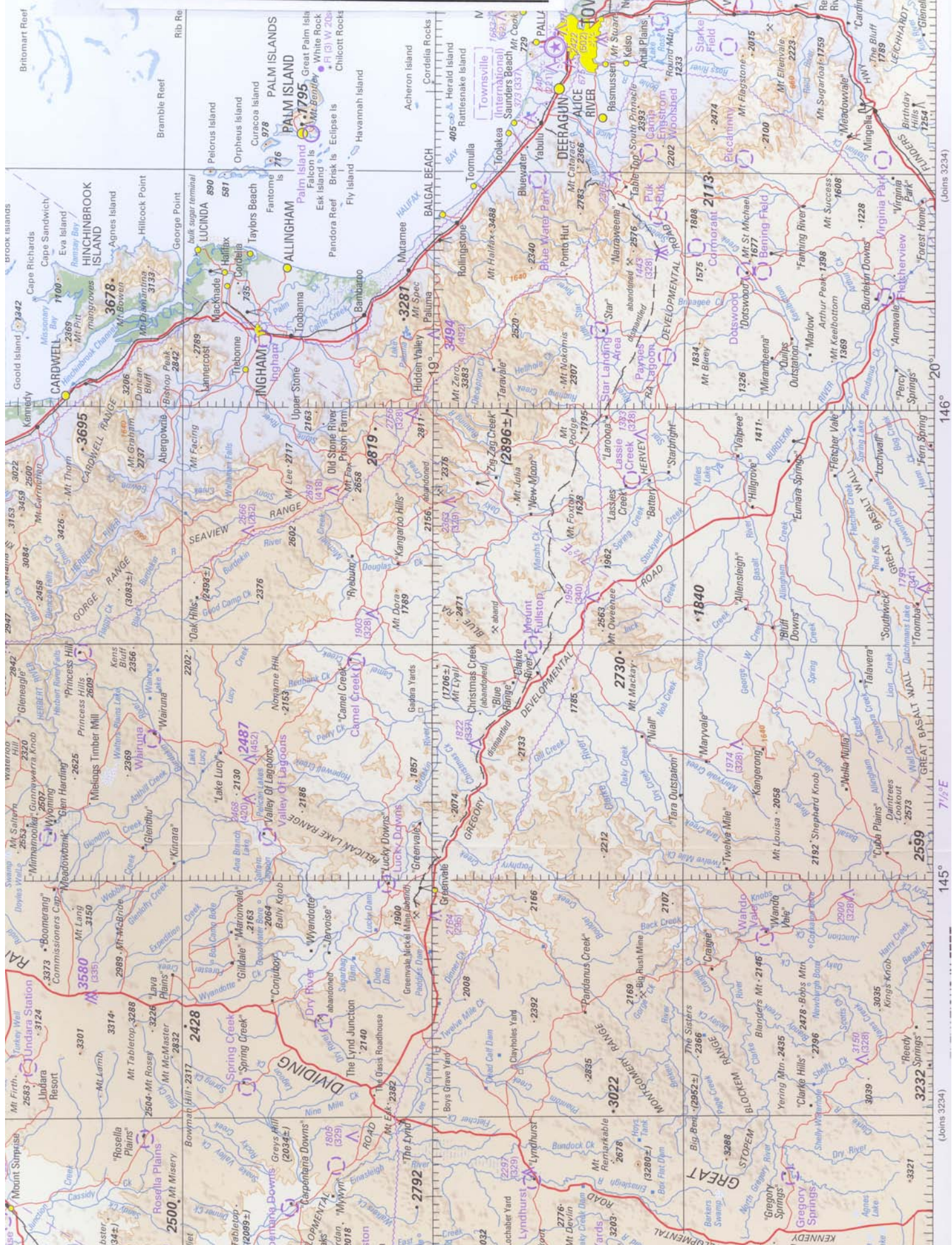

(Joins 3234)

146°

145°

(Joins 3234)

147°

BOURKE (3356) WAC EXTRACT - 30

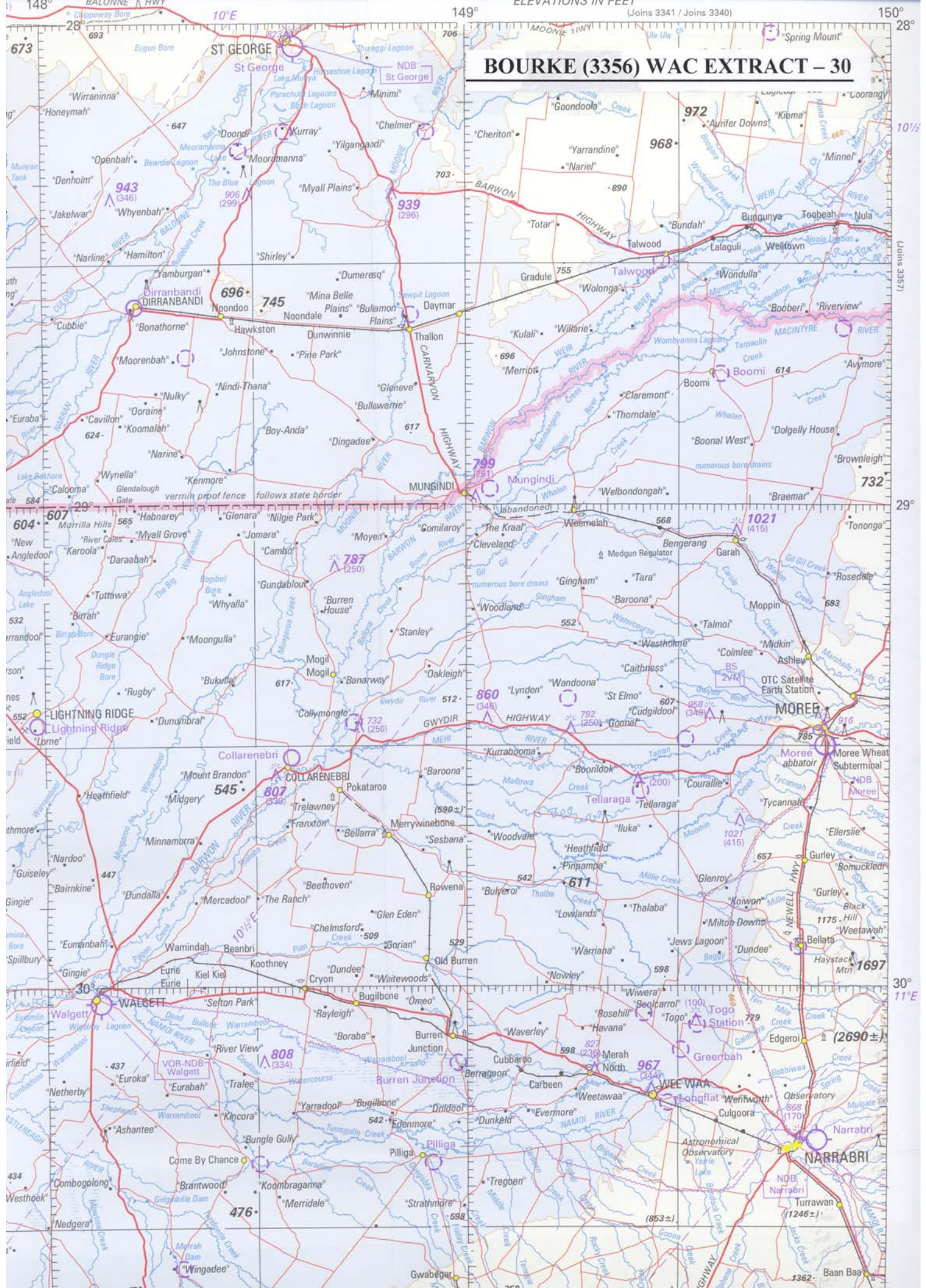

BOURKE (3356) WAC EXTRACT - 30

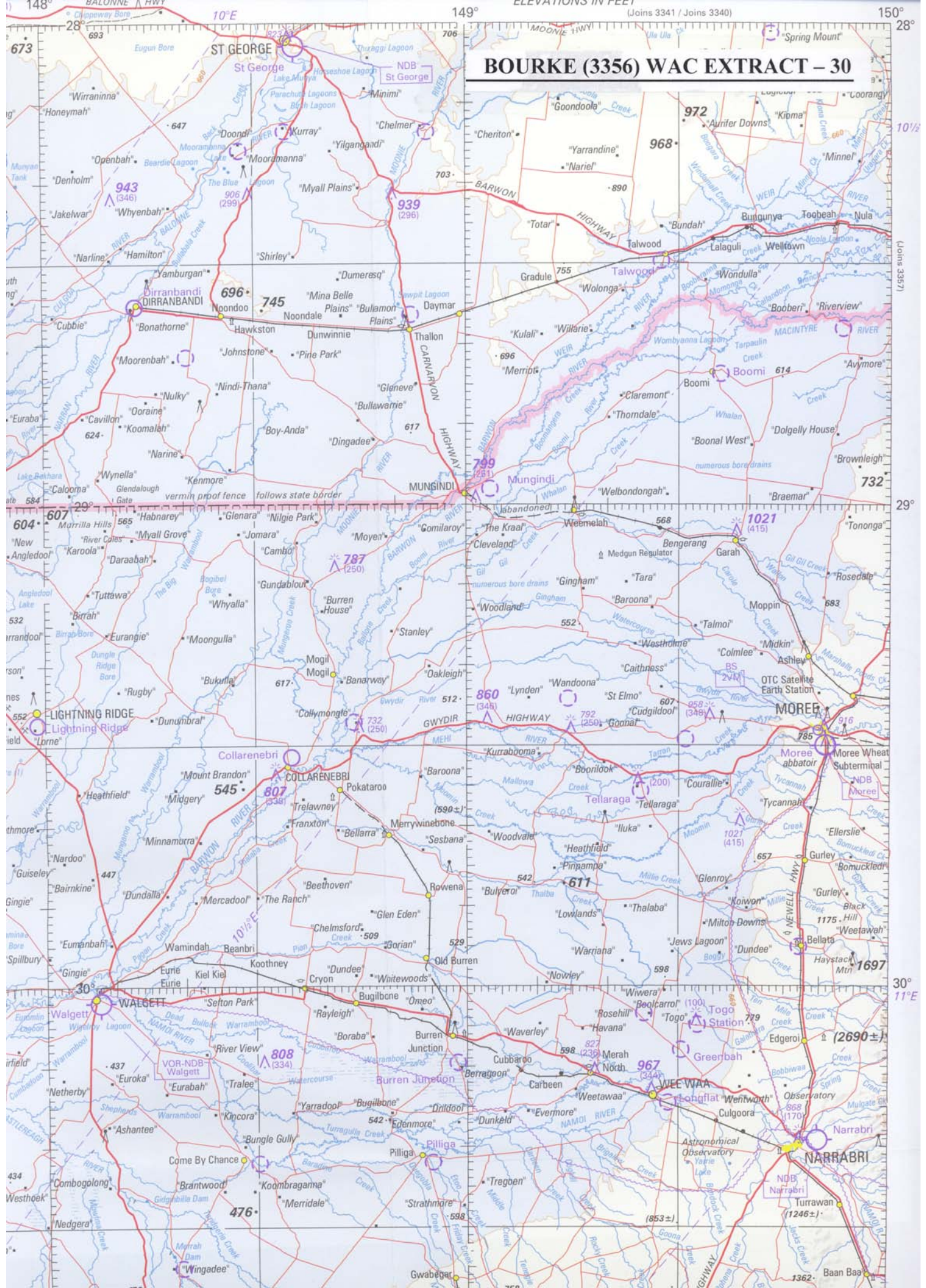

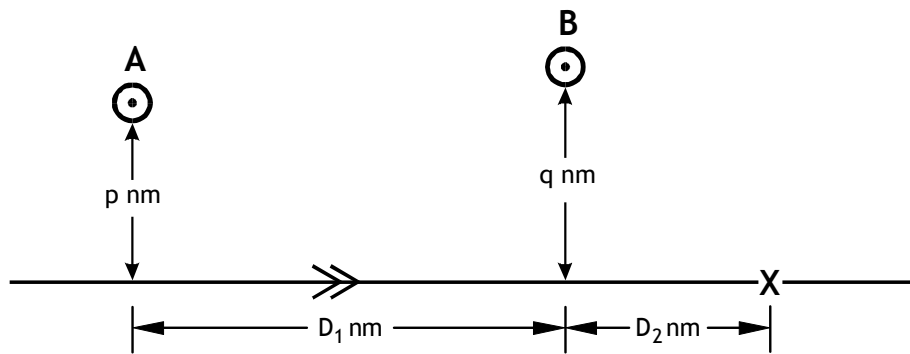

Figure 16

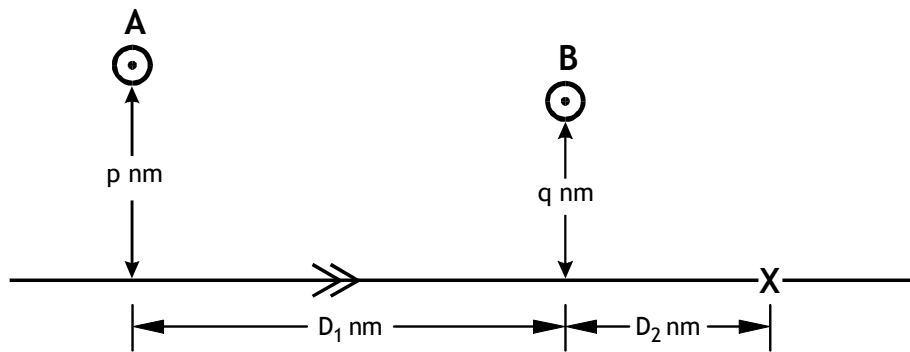

Figure 17

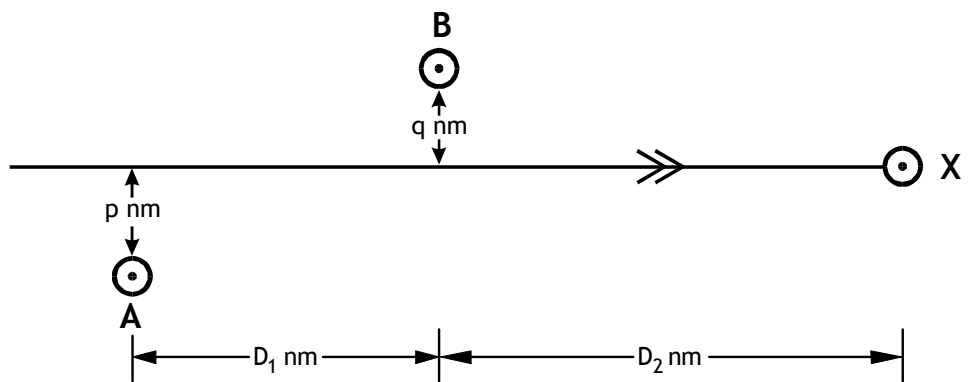

Figure 18

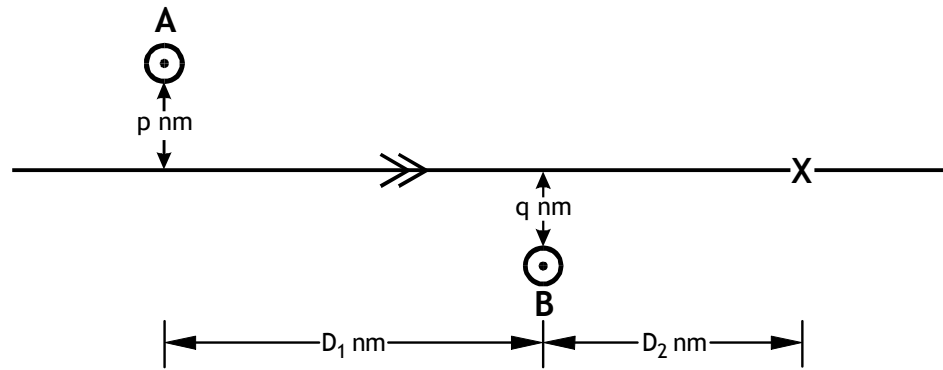

Figure 19

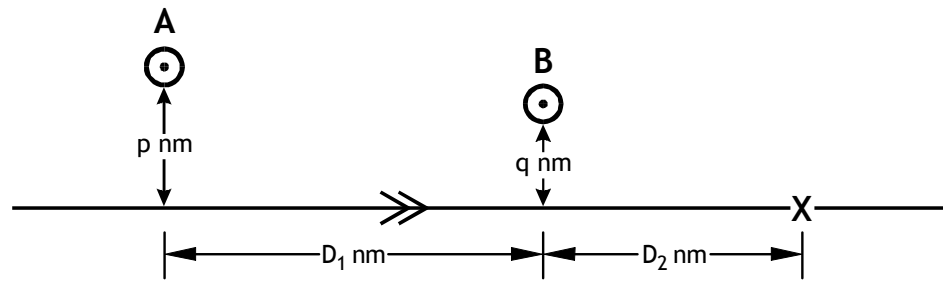

Figure 20

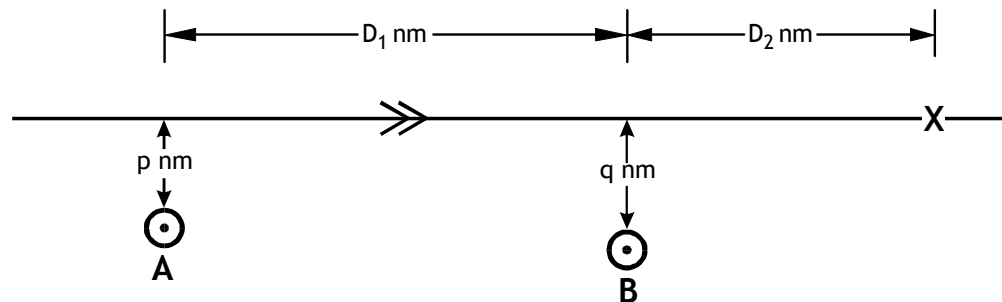

Figure 21

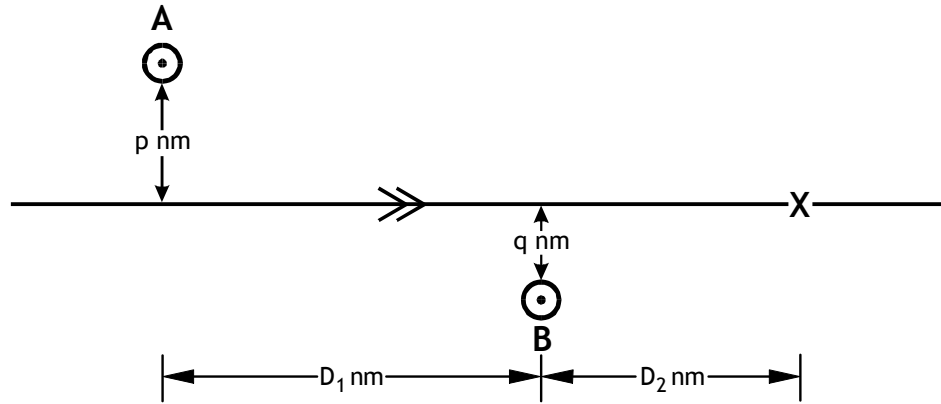

Figure 22

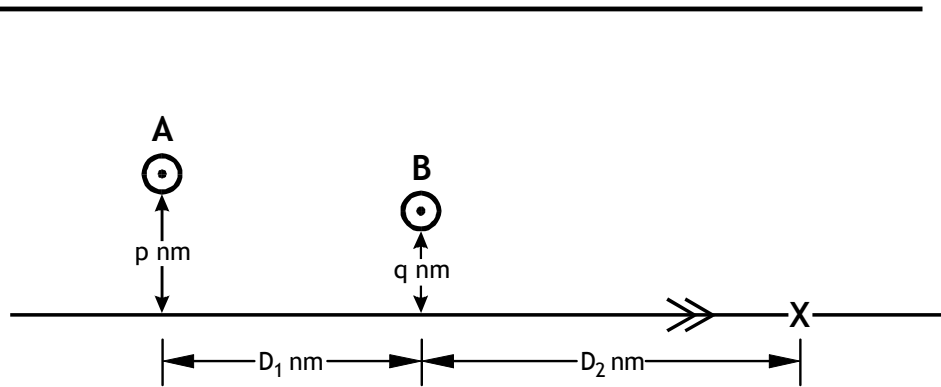

Figure 23

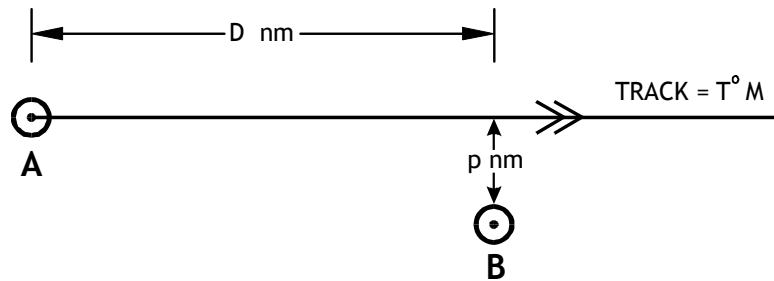

Figure 24

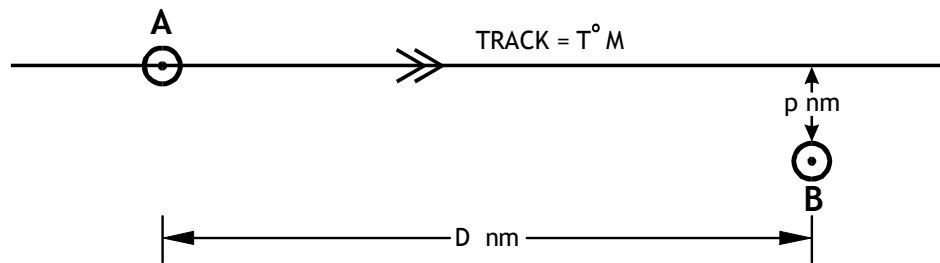

Figure 25

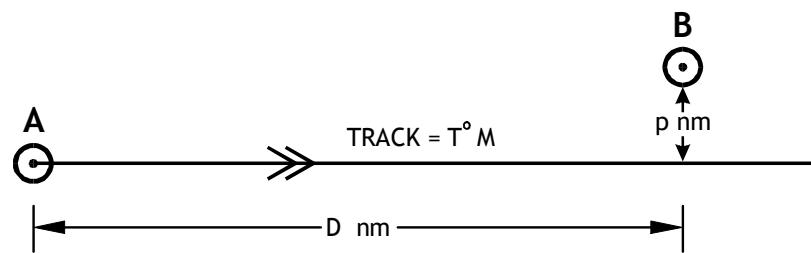

Figure 26

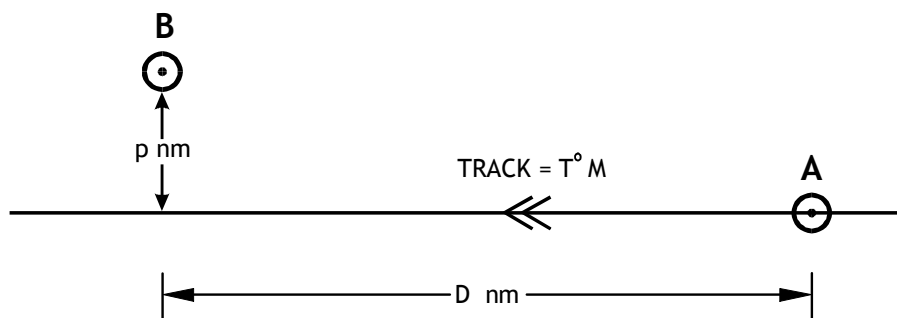

Figure 27

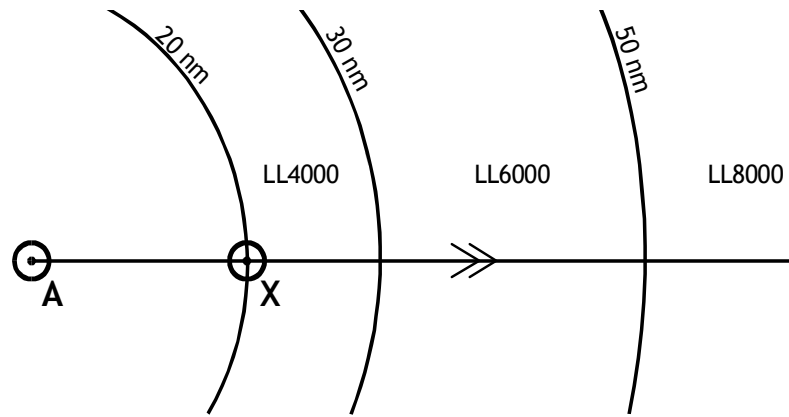

Figure 28

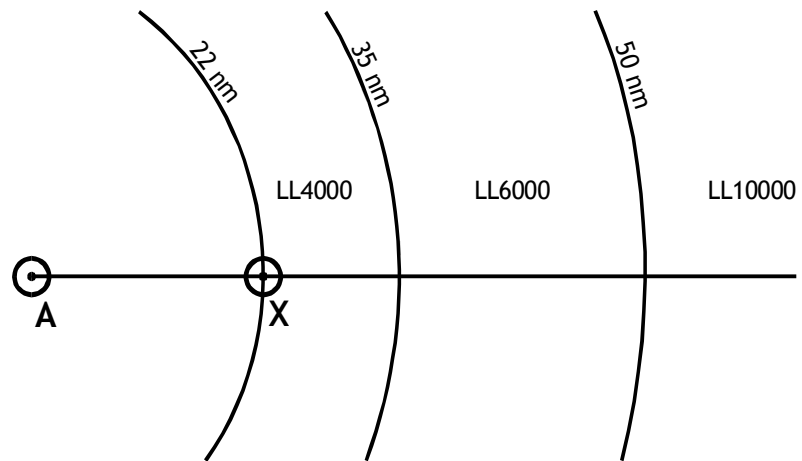

Figure 29

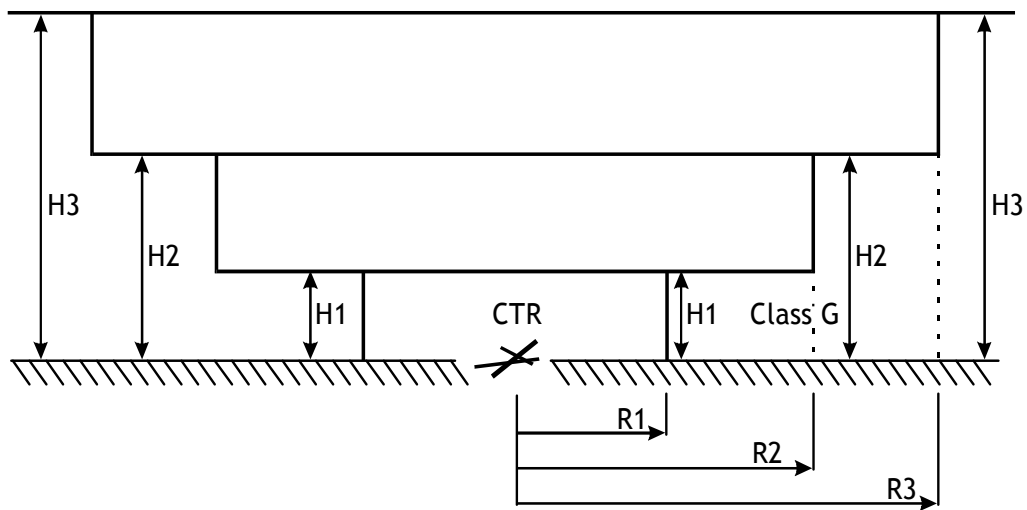

Figure 29A

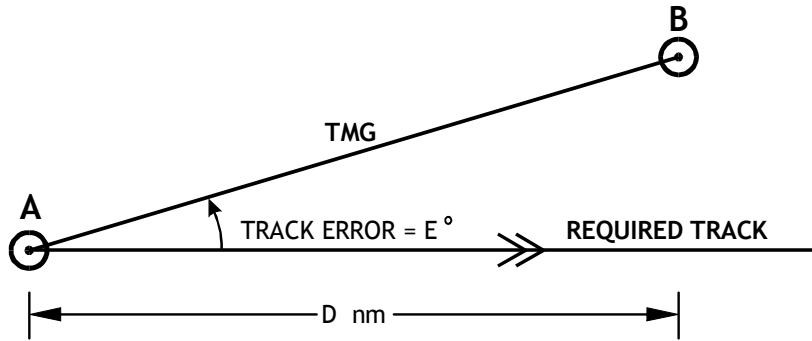

Figure 30

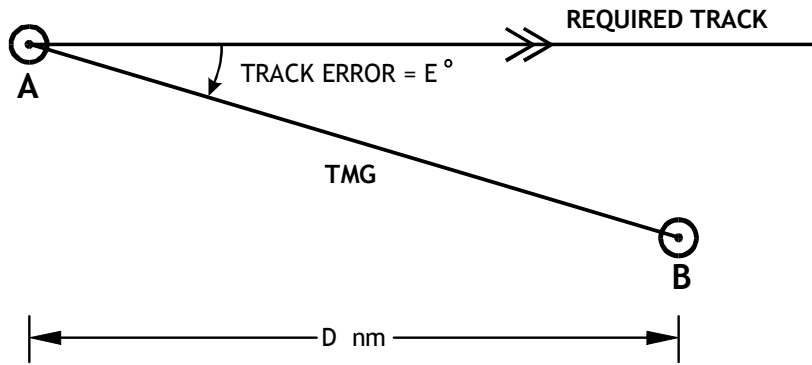

Figure 31

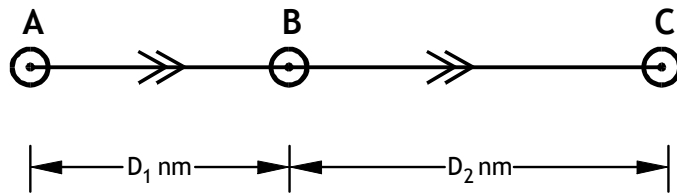

Figure 32

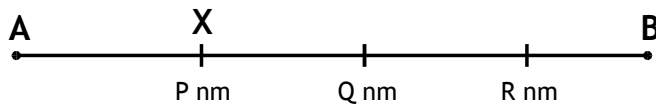

Figure 33

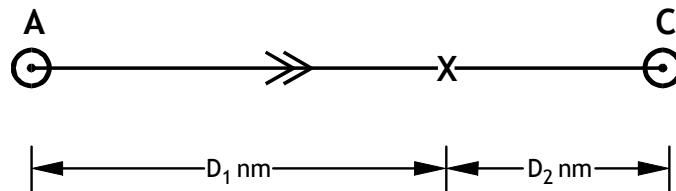

Figure 34

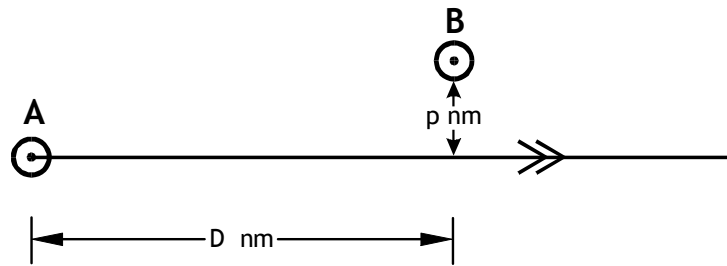

Figure 35

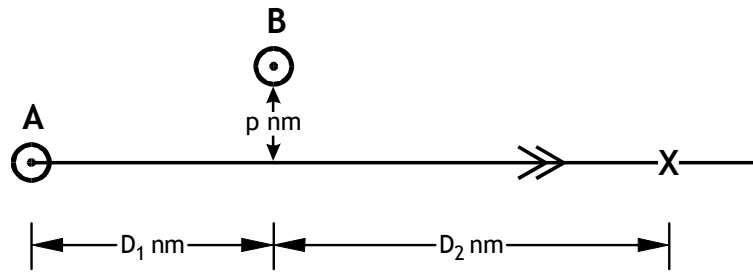

Figure 36

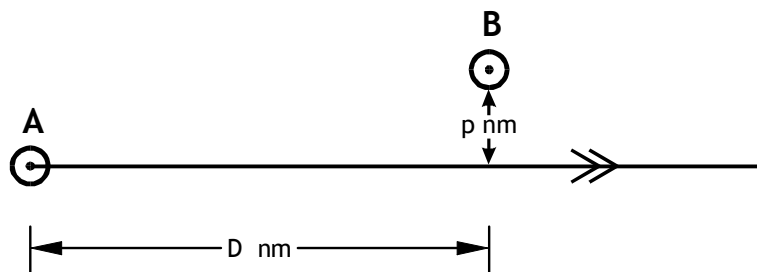

Figure 37

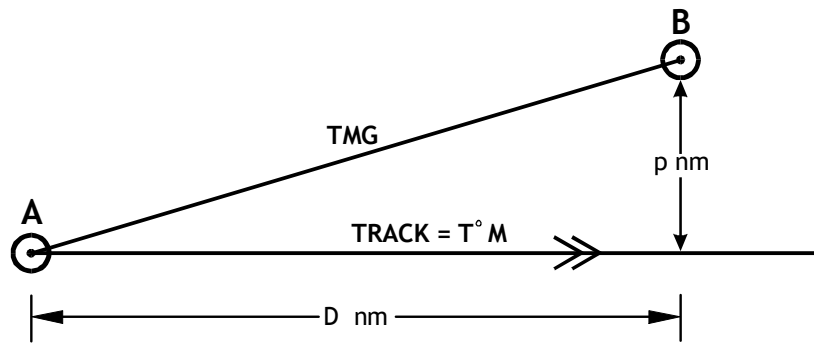

Figure 38

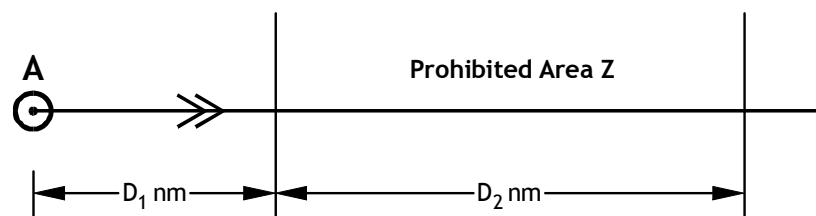

Figure 39

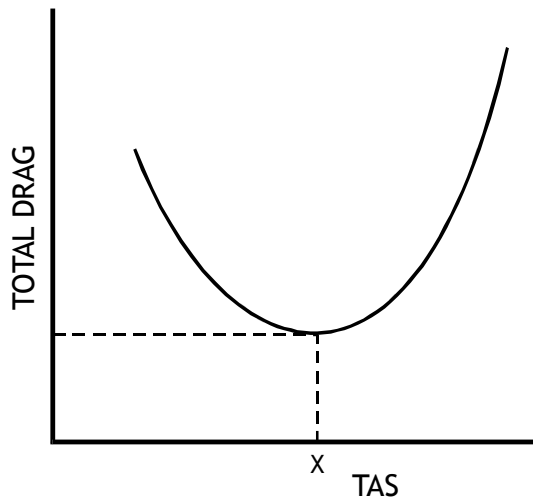

Figure 40

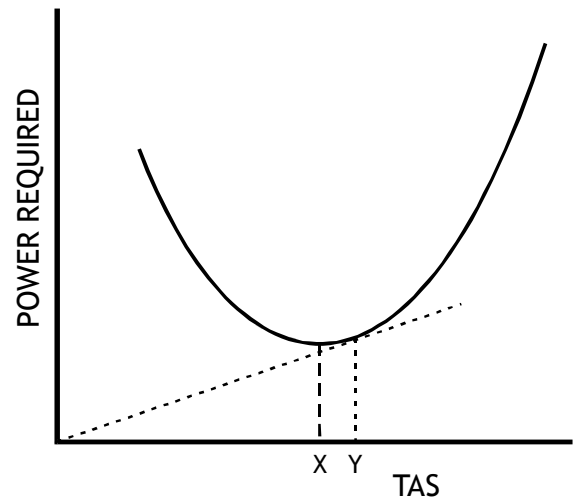

Figure 41

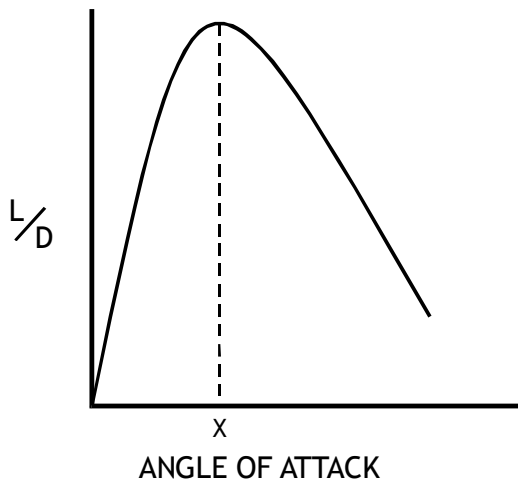

Figure 42

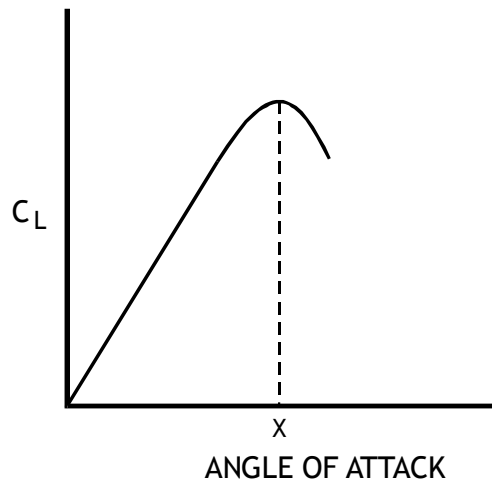
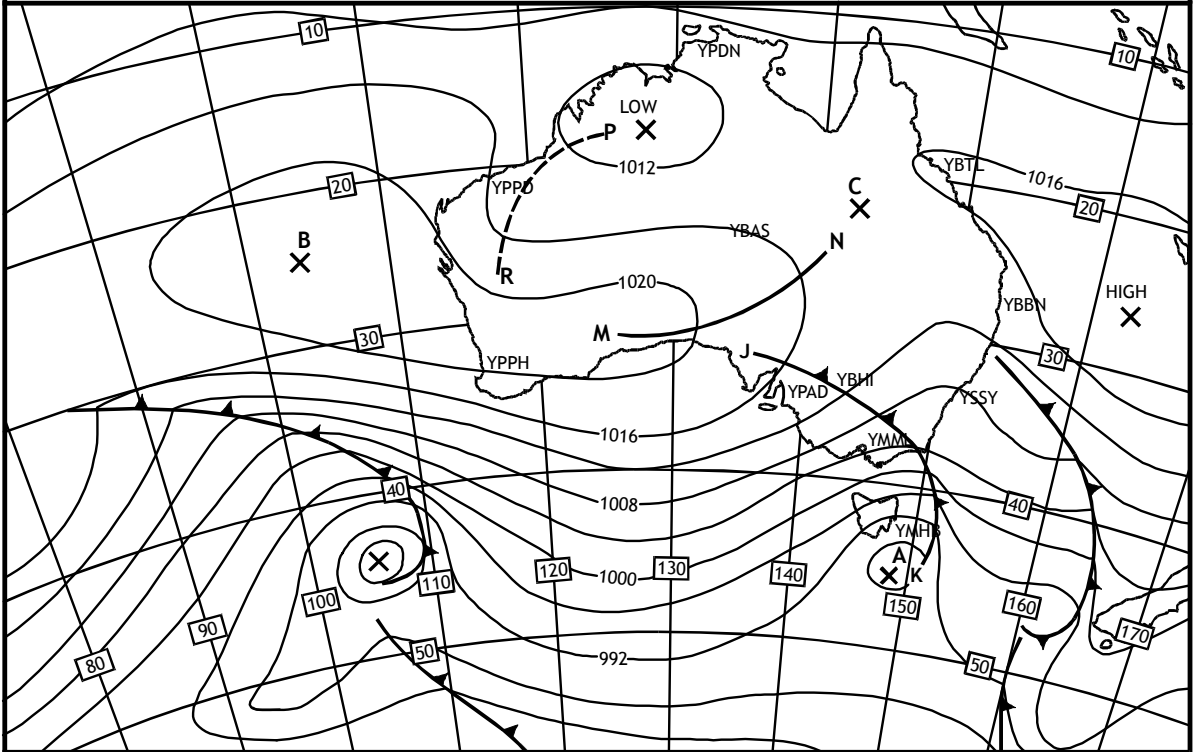
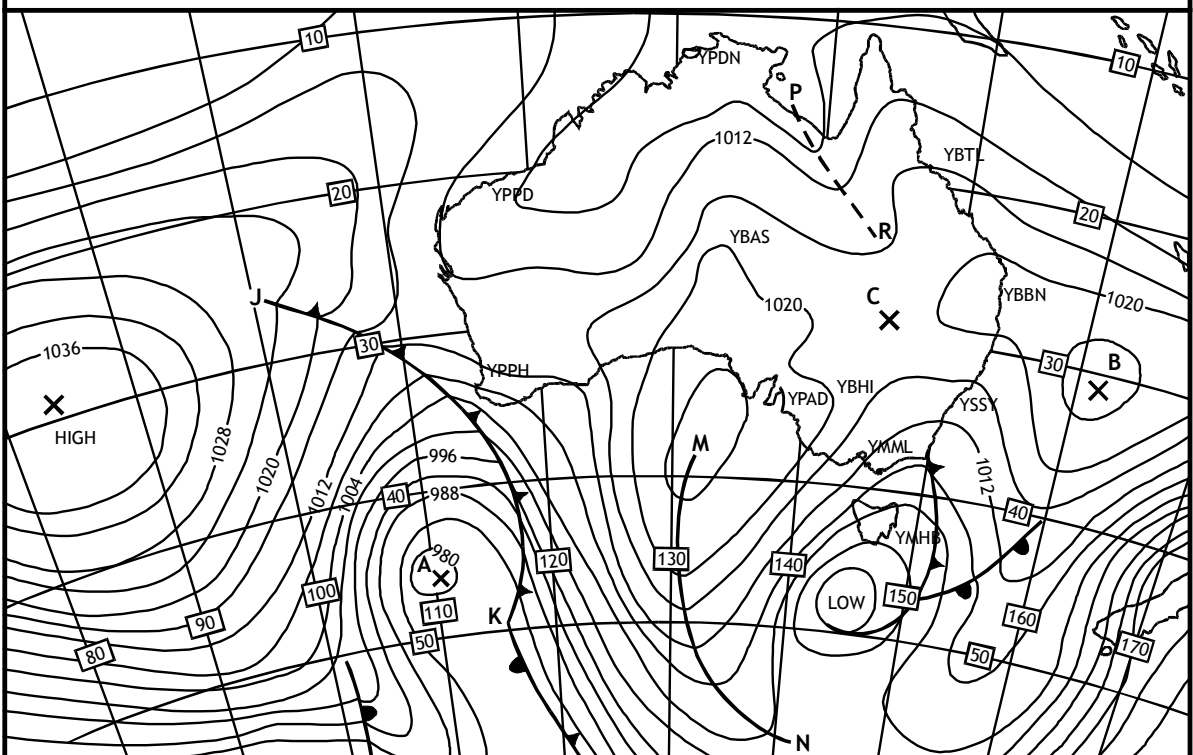

Figure 43

MSL ANALYSIS - Figure 48



MSL ANALYSIS - Figure 49



MSL ANALYSIS - Figure 49

ARFOR No. 1

AREA 21 (21)

AMEND AREA FORECAST 090200 TO 091700 AREA 21

OVERVIEW

SURFACE TROUGH AT 2200 Z: THROUGH YYNG/YMER

0500 Z: YBTH/YSNW

1100 Z : EAST OF AREA

SCATTERED SHOWERS AND THUNDERSTORMS. INCLUDING ISOLATED HAIL. AREAS OF RAIN. CONTRACTING EASTWARDS ISOLATED FOG AFTER 1100Z

REFER SIGMET RE SQUALLS AND HAIL.

SUBDIVISIONS:

A: E OF TROUGH: B: W OF TROUGH

AMD WIND

2000	5000	7000	10000	14000	18500
A : 350/25	340/30	340/35	340/40	340/50 M504	340/55 MS14
B : 260/25	260/30	260/30	280/30 ZERO	280/40 MS08	280/60 MS17

AMD CLOUD

AREAS OF BKN ST 1000/3000 W SLOPES 3000/5000 RANGES.

ALSO WITH PRECIPITATION 1000/3000 COAST/SEA

BKN CUSC 2500/10000 W SLOPES 4500/11000 W RANGES

SCT CUSC 2500/10000 COAST/SEA 4500/11000 E RANGES

ISOL CB 5000/35000

BKN ACAS ABV 10000 CONTRACTING E

AMD WEATHER

RA CONTRACTING E SH/TS WITH HAIL FOG AFTER 11

VISIBILITY

5000M SH/RA 3000 TS

AMD FREEZING LEVEL

A: 12000 B: 9500

AMD ICING

MOD IN CU 9500/11000 AND AC

AMD TURBULENCE

MOD WITH CU AND AC

MOD TO ISOL SEV RANGES/COAST/60NM OFFSHORE

NOTE: REFER SIGMET RE SQUALLS AND HAIL

ARFOR No. 2

AREA 21 (21)

AMEND AREA FORECAST 090100 TO 091700 AREA 21

OVERVIEW:

SURFACE TROUGH AT 0400 Z : THROUGH YSWG/YMCO

1000 Z : YCWR/YMRY

1600 Z : EAST OF AREA

SCATTERED SHOWERS AND THUNDERSTORMS. INCLUDING ISOLATED HAIL. AREAS OF RAIN. CONTRACTING EASTWARDS ISOLATED FOG AFTER 1600Z REFER SIGMET RE SQUALLS AND HAIL.

SUBDIVISIONS:

A: E OF TROUGH

B: W OF TROUGH

AMD WIND:

	2000	5000	7000	10000	14000	18500
A:	350/25	340/30	340/35	340/40	340/50 MS04	340/55 MS14
B :	260/25	260/30	260/30	280/30 ZERO	280/40 MS08	280/60 MS17

AMD CLOUD:

AREAS OF SCT ST 1000/3000 W SLOPES 3000/5000 RANGES.

ALSO WITH PRECIPITATION 1000/3000 COAST/SEA

BKN CUSC 2500/10000 W SLOPES 4500/11000 W RANGES

SCT CUSC 2500/10000 COAST/SEA 4500/11000 E RANGES

ISOL CB 5000/35000

BKN ACAS ABV 10000 CONTRACTING E

AMD WEATHER:

RA CONTRACTING E SH/TS WITH HAIL FOG AFTER 16

VISIBILITY

5000M SH/RA 3000 TS

AMD FREEZING LEVEL

A: 12000 B: 9500

AMD ICING

MOD IN CU 9500/11000 AND AC

AMD TURBULENCE:

MOD WITH CU AND AC

MOD TO ISOL SEV RANGES/COAST/60NM OFFSHORE

ARFOR No. 3

AREA 21 (21)

AMEND AREA FORECAST 092300 TO 101100 AREA 21

OVERVIEW:

WEAK SURFACE TROUGH THROUGH NSW SLOPING WEST WITH HEIGHT,

AT 23 Z: 10000FT ABOUT PARKES/MORUYA

18500FT ABOUT WAGGA/ORBOST

SUBDIVISIONS:

A: E OF TROUGH

B: W OF TROUGH

AMD WIND:

	2000	5000	7000	10000	14000	18500
A:	240/25	250/25	250/25	280/35 MS04	280/50 MS11	280/70 MS20
B:	240/30	240/30	240/30	240/30 MS06	240/35 MS13	220/45 MS22

AMD CLOUD

SCT ST 1000/3000 SW SLOPES. BKN RANGES TILL 02

SCT CUSC 5000/7000 RANGES/SLOPES. BKN SLOPES IN S

SCT CU 4000/7000 SEA/COAST

AMD WEATHER

ISOL SHOWERS RANGES/W SLOPES S OF 35S

ISOL SHOWER SEA

VISIBILITY:

5000M SHOWERS

AMD FREEZING LEVEL:

6000 S OF 35S / 9000 N

AMD ICING

MOD IN CU TOPS

AMD TURBULENCE

MOD BLW 10000 RANGES/E

ARFOR No. 4

AREA 21 (21)

AMEND AREA FORECAST 092300 TO 101100 AREA 21

OVERVIEW:

WEAK SURFACE TROUGH AT 0200 Z : THROUGH YSWG/YORB

0700 Z : YPKS/YMRY

1100 Z : YBTH/YSNW

SUBDIVISIONS:

A : E OF TROUGH

B : W OF TROUGH

AMD WIND :

2000	5000	7000	10000	14000	18500
A: 240/25	250/25	250/25	280/35 MS04	280/50 MS11	280/70 MS20
B: 240/30	240/30	240/30	240/30 MS06	240/35 MS13	220/45 MS22

AMD CLOUD:

SCT ST 1000/3000 SW SLOPES. BKN RANGES TILL 08

SCT CUSC 5000/7000 RANGES/SLOPES. BKN SLOPES IN S

SCT CU 4000/7000 SEA/COAST

AMD WEATHER:

ISOL SHOWERS RANGES/W SLOPES S OF 35S

ISOL SHOWER SEA

VISIBILITY:

5000M SHOWERS

AMD FREEZING LEVEL:

A: 8000 B: 9000

AMD ICING

MOD IN CU TOPS

AMD TURBULENCE:

MOD BLW 10000 RANGES/E

ARFOR No. 5

AREA 21 (21)

AREA FORECAST 062100 TO 071100 AREA 21

OVERVIEW:

ISOLATED SHOWERS CHIEFLY ALONG COAST WITH AREAS OF LOW CLOUD TILL 04Z

PATCHY RAIN NORTH OF ORANGE/SYDNEY. ISOL FOGS RANGES/EAST TILL 23Z

SUBDIVISIONS:

NIL

WIND

2000	5000	7000	10000	14000	18500
VRB/15	260/15	260/15	260/25 ZERO	270/30 MS08	270/40 MS17

CLOUD

AREAS OF BKN ST 1000/3000 SEA/COAST TILL 04
3000/5000 RANGES IN E TILL 02

AREAS OF CU/SC 3000/8000 SEA/COAST ISOL TOPS SEA 20000

SCT CU/SC 4000/8000 RANGES, BKN IN S AND E

SCT SC 5000/8000 W SLOPES

AREAS OF BKN ACAS ABOVE 11000

WEATHER:

SH IN E. PATCHY RA N OF YORG/YSSY

ISOL FOG RANGES AND EAST TILL 23

VISIBILITY:

5000 SH/RA

FREEZING LEVEL

10000

ICING

MOD IN CU/AC

TURBULENCE:

MOD IN CU/AC

CRITICAL LOCATIONS: (HEIGHT ABOVE MSL)

MT VICTORIA: BKN SC 4000
FM23 5000M SH BKN CU 5000

BOWRAL: 500M FOG
FM22 5000M BKN ST 3000
FM00 8000M BKN SC 4500

ARFOR No. 6

AREA 22 (22)

AREA FORECAST 112300 TO 121100 AREA 22

OVERVIEW:

THUNDERSTORMS WITH HAIL (SMALL) DEVELOPING IN W AREA 22 EXTENDING E
SCATTERED SHOWERS/DRIZZLE

WIDESPREAD LOW CLOUD, BECOMING SCATTERED NW

ISOLATED SEVERE TURBULENCE BELOW 8000

REFER SIGMET FOR LATEST DETAILS OF SEVERE ICING

WIND:

2000	5000	7000	10000	14000	18500
270/40	270/35	260/40	270/45 MS10	270/50 MS18	260/60 MS28

CLOUD:

OCNL CB 2500/28000 W AREA 22 EXTENDING E

BKN ST 800/3000, BECOMING SCT NW

BKN CU 2500/15000

WEATHER:

TS (HAIL) SH/DZ

VISIBILITY:

4000M SH/DZ/TS

FREEZING LEVEL:

4000S/5000N

ICING:

REFER SIGMET

TURBULENCE:

ISOL SEV BELOW 8000

