

**Q.1 – Q.20 Carry One Mark Each**

1. If  $E$  denotes expectation, the variance of a random variable  $X$  is given by  
 (A)  $E[X^2] - E^2[X]$  (B)  $E[X^2] + E^2[X]$  (C)  $E[X^2]$  (D)  $E^2[X]$

2. The following plot shows a function  $y$  which varies linearly with  $x$ . The value of the integral  $I = \int_1^2 y \, dx$  is

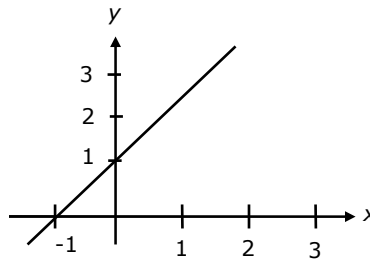

- (A) 1.0 (B) 2.5 (C) 4.0 (D) 5.0
3. For  $|x| \ll 1$ ,  $\coth(x)$  can be approximated as  
 (A)  $x$  (B)  $x^2$  (C)  $\frac{1}{x}$  (D)  $\frac{1}{x^2}$
4.  $\lim_{\theta \rightarrow 0} \frac{\sin(\theta/2)}{\theta}$  is:  
 (A) 0.5 (B) 1 (C) 2 (D) not defined
5. Which one of the following functions is strictly bounded?  
 (A)  $\frac{1}{x^2}$  (B)  $e^x$  (C)  $x^2$  (D)  $e^{-x^2}$
6. For the function  $e^{-x}$ , the linear approximation around  $x = 2$  is:  
 (A)  $(3 - x)e^{-2}$  (B)  $1 - x$   
 (C)  $[3 + 2\sqrt{2} - (1 + \sqrt{2})x]e^{-2}$  (D)  $e^{-2}$
7. An independent voltage source in series with an impedance  $Z_s = R_s + jX_s$  delivers a maximum average power to a load impedance  $Z_L$  when  
 (A)  $Z_L = R_s + jX_s$  (B)  $Z_L = R_s$   
 (C)  $Z_L = jX_s$  (D)  $Z_L = R_s - jX_s$



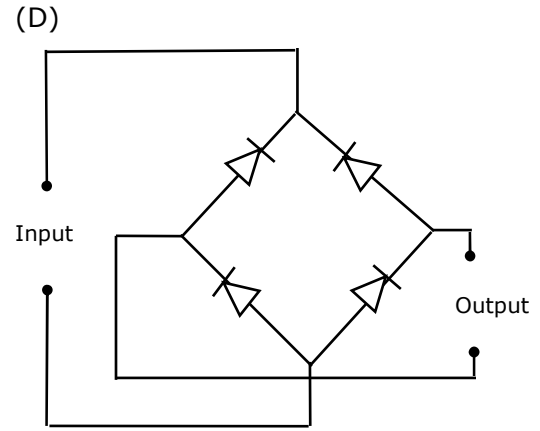
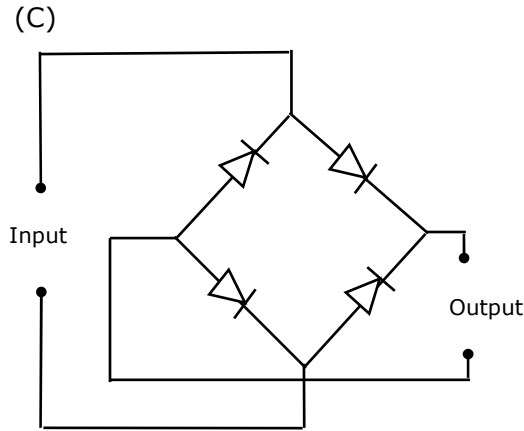

12. In a transconductance amplifier, it is desirable to have  
 (A) a large input resistance and a large output resistance  
 (B) a large input resistance and a small output resistance  
 (C) a small input resistance and a large output resistance  
 (D) a small input resistance and a small output resistance
13.  $X = 01110$  and  $Y = 11001$  are two 5-bit binary numbers represented in two's complement format. The sum of  $X$  and  $Y$  represented in two's complement format using 6 bits is:  
 (A) 100111                      (B) 001000                      (C) 000111                      (D) 101001
14. The Boolean function  $Y = AB + CD$  is to be realized using only 2-input NAND gates. The minimum number of gates required is:  
 (A) 2                                  (B) 3                                  (C) 4                                  (D) 5
15. If the closed-loop transfer function of a control system is given as  
 $T(s) = \frac{s-5}{(s+2)(s+3)}$ , then it is  
 (A) an unstable system                      (B) an uncontrollable system  
 (C) a minimum phase system                      (D) a non-minimum phase system
16. If the Laplace transform of a signal  $y(t)$  is  $Y(s) = \frac{1}{s(s-1)}$ , then its final value is:  
 (A) -1                                  (B) 0                                  (C) 1                                  (D) unbounded
17. If  $R(\tau)$  is the autocorrelation function of a real, wide-sense stationary random process, then which of the following is NOT true?  
 (A)  $R(\tau) = R(-\tau)$                       (B)  $|R(\tau)| \leq R(0)$                       (C)  $R(\tau) = -R(-\tau)$   
 (D) The mean square value of the process is  $R(0)$

18. If  $S(f)$  is the power spectral density of a real, wide-sense stationary random process, then which of the following is ALWAYS true?

(A)  $S(0) \geq S(f)$       (B)  $S(f) \geq 0$       (C)  $S(-f) = -S(f)$       (D)  $\int_{-\infty}^{\infty} S(f) df = 0$

19. A plane wave of wavelength  $\lambda$  is traveling in a direction making an angle  $30^\circ$  with positive x-axis and  $90^\circ$  with positive y-axis. The  $\vec{E}$  field of the plane wave can be represented as ( $E_0$  is constant)

(A)  $\vec{E} = \sqrt{2} E_0 e^{j\left(\omega t - \frac{\sqrt{3}\pi}{\lambda} x - \frac{\pi}{\lambda} z\right)}$       (B)  $\vec{E} = \sqrt{2} E_0 e^{j\left(\omega t - \frac{\pi}{\lambda} x - \frac{\sqrt{3}\pi}{\lambda} z\right)}$   
 (C)  $\vec{E} = \sqrt{2} E_0 e^{j\left(\omega t + \frac{\sqrt{3}\pi}{\lambda} x + \frac{\pi}{\lambda} z\right)}$       (D)  $\vec{E} = \sqrt{2} E_0 e^{j\left(\omega t - \frac{\pi}{\lambda} x + \frac{\sqrt{3}\pi}{\lambda} z\right)}$

20. If  $C$  is a closed curve enclosing a surface  $S$ , then the magnetic field intensity  $\vec{H}$ , the current density  $\vec{J}$  and the electric flux density  $\vec{D}$  are related by

(A)  $\iint_S \vec{H} \cdot d\vec{s} = \oint_C \left( \vec{J} + \frac{\partial \vec{D}}{\partial t} \right) \cdot d\vec{l}$       (B)  $\int_C \vec{H} \cdot d\vec{l} = \oint_S \left( \vec{J} + \frac{\partial \vec{D}}{\partial t} \right) \cdot d\vec{s}$   
 (C)  $\oint_S \vec{H} \cdot d\vec{s} = \int_C \left( \vec{J} + \frac{\partial \vec{D}}{\partial t} \right) \cdot d\vec{l}$       (D)  $\oint_C \vec{H} \cdot d\vec{l} = \iint_S \left( \vec{J} + \frac{\partial \vec{D}}{\partial t} \right) \cdot d\vec{s}$

**Q.21 – Q.75 Carry Two Marks Each**

21. It is given that  $X_1, X_2, \dots, X_M$  are  $M$  non-zero, orthogonal vectors. The dimension of the vector space spanned by the  $2M$  vectors  $X_1, X_2, \dots, X_M, -X_1, -X_2, \dots, -X_M$  is:

(A)  $2M$       (B)  $M + 1$       (C)  $M$   
 (D) dependent on the choice of  $X_1, X_2, \dots, X_M$

22. Consider the function  $f(x) = x^2 - x - 2$ . The maximum value of  $f(x)$  in the closed interval  $[-4, 4]$  is:

(A) 18      (B) 10  
 (C) -2.25      (D) indeterminate

23. An examination consists of two papers, Paper 1 and Paper 2. The probability of failing in Paper 1 is 0.3 and that in Paper 2 is 0.2. Given that a student has failed in Paper 2, the probability of failing in Paper 1 is 0.6. The probability of a student failing in both the papers is:

(A) 0.5      (B) 0.18      (C) 0.12      (D) 0.06

24. The solution of the differential equation  $k^2 \frac{d^2y}{dx^2} = y - y_2$  under the boundary conditions (i)  $y = y_1$  at  $x = 0$  and (ii)  $y = y_2$  at  $x = \infty$ , where  $k, y_1$  and  $y_2$  are constants, is

- (A)  $y = (y_1 - y_2) \exp(-x/k^2) + y_2$                       (B)  $y = (y_2 - y_1) \exp(-x/k) + y_1$   
 (C)  $y = (y_1 - y_2) \sinh(x/k) + y_1$                       (D)  $y = (y_1 - y_2) \exp(-x/k) + y_2$

25. The equation  $x^3 - x^2 + 4x - 4 = 0$  is to be solved using the Newton-Raphson method. If  $x = 2$  is taken as the initial approximation of the solution, then the next approximation using this method will be:

- (A)  $\frac{2}{3}$                       (B)  $\frac{4}{3}$                       (C) 1                      (D)  $\frac{3}{2}$

26. Three functions  $f_1(t), f_2(t)$  and  $f_3(t)$ , which are zero outside the interval  $[0, T]$ , are shown in the figure. Which of the following statements is correct?

- (A)  $f_1(t)$  and  $f_2(t)$  are orthogonal  
 (B)  $f_1(t)$  and  $f_3(t)$  are orthogonal  
 (C)  $f_2(t)$  and  $f_3(t)$  are orthogonal  
 (D)  $f_1(t)$  and  $f_2(t)$  are orthonormal

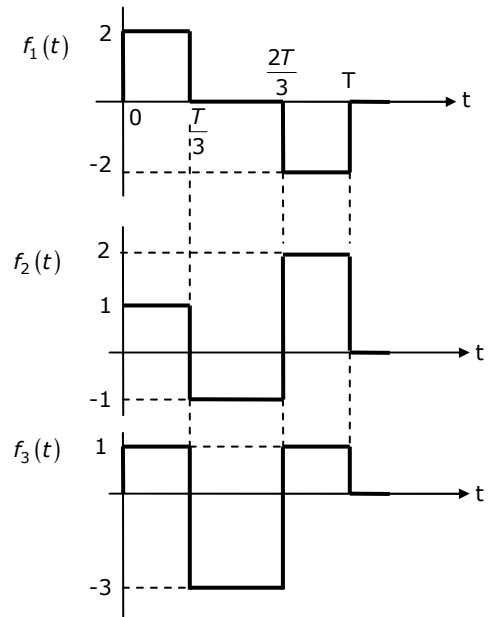

27. If the semi-circular contour D of radius 2 is as shown in the figure, then the value of the integral  $\oint_D \frac{1}{(s^2 - 1)} ds$  is:

$$\oint_D \frac{1}{(s^2 - 1)} ds$$

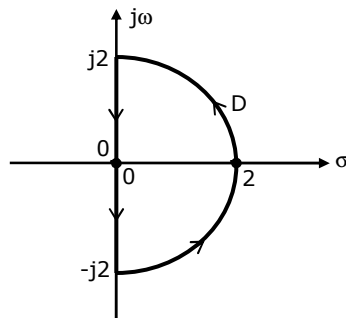

- (A)  $j\pi$                       (B)  $-j\pi$                       (C)  $-\pi$                       (D)  $\pi$

28. Two series resonant filters are as shown in the figure. Let the 3-dB bandwidth of Filter 1 be  $B_1$  and that of Filter 2 be  $B_2$ . The value of  $\frac{B_1}{B_2}$  is:

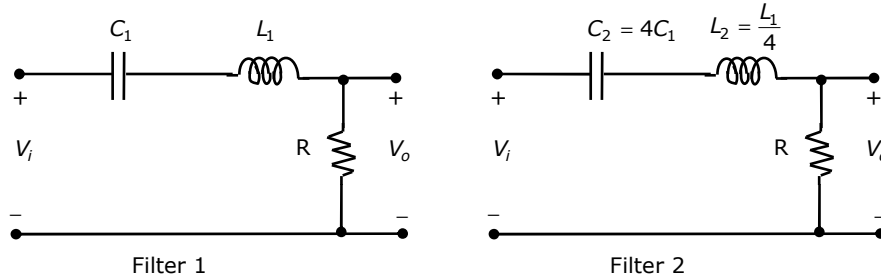

- (A) 4                      (B) 1                      (C)  $\frac{1}{2}$                       (D)  $\frac{1}{4}$

29. For the circuit shown in the figure, the Thevenin voltage and resistance looking into X-Y are:

- (A)  $\frac{4}{3}V, 2\Omega$                       (B)  $4V, \frac{2}{3}\Omega$   
(C)  $\frac{4}{3}V, \frac{2}{3}\Omega$                       (D)  $4V, 2\Omega$

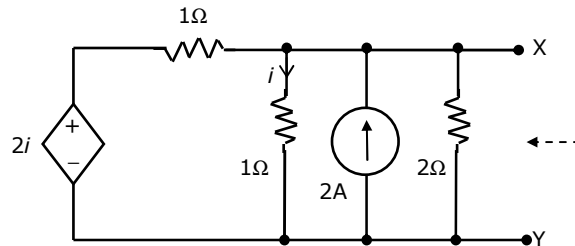

30. In the circuit shown,  $V_C$  is 0 volts at  $t = 0$  sec. For  $t > 0$ , the capacitor current  $i_c(t)$ , where  $t$  is in seconds, is given by

- (A)  $0.50 \exp(-25t)$  mA  
(B)  $0.25 \exp(-25t)$  mA  
(C)  $0.50 \exp(-12.5t)$  mA  
(D)  $0.25 \exp(-6.25t)$  mA

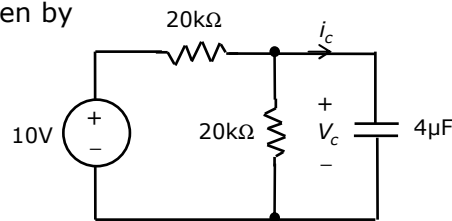

31. In the AC network shown in the figure, the phasor voltage  $V_{AB}$  (in Volts) is:

- (A) 0  
(B)  $5\angle 30^\circ$   
(C)  $12.5\angle 30^\circ$   
(D)  $17\angle 30^\circ$

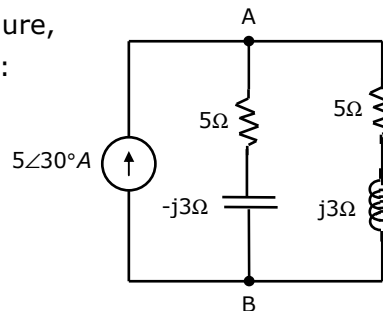

32. A  $p^+n$  junction has a built-in potential of 0.8 V. The depletion layer width at a reverse bias of 1.2V is  $2 \mu\text{m}$ . For a reverse bias of 7.2 V, the depletion layer width will be:

- (A)  $4 \mu\text{m}$                       (B)  $4.9 \mu\text{m}$                       (C)  $8 \mu\text{m}$                       (D)  $12 \mu\text{m}$

33. Group I lists four types of  $p-n$  junction diodes. Match each device in Group I with one of the option in Group II to indicate the bias condition of that device in its normal mode of operation.

**Group I**

**Group II**

(P) Zener Diode

(1) Forward bias

(Q) Solar cell

(2) Reverse bias

(R) LASER diode

(S) Avalanche Photodiode

(A) P-1 Q-2 R-1 S-2

(B) P-2 Q-1 R-1 S-2

(C) P-2 Q-2 R-1 S-1

(D) P-2 Q-1 R-2 S-2

34. The DC current gain ( $\beta$ ) of a BJT is 50. Assuming that the emitter injection efficiency is 0.995, the base transport factor is:

(A) 0.980

(B) 0.985

(C) 0.990

(D) 0.995

35. Group I lists four different semiconductor devices. Match each device in Group I with its characteristic property in Group II.

**Group I**

**Group II**

(P) BJT

(1) Population inversion

(Q) MOS capacitor

(2) Pinch-off voltage

(R) LASER diode

(3) Early effect

(S) JFET

(4) Flat-band voltage

(A) P-3 Q-1 R-4 S-2

(B) P-1 Q-4 R-3 S-2

(C) P-3 Q-4 R-1 S-2

(D) P-3 Q-2 R-1 S-4

36. For the Op-Amp circuit shown in the figure,  $V_o$  is:

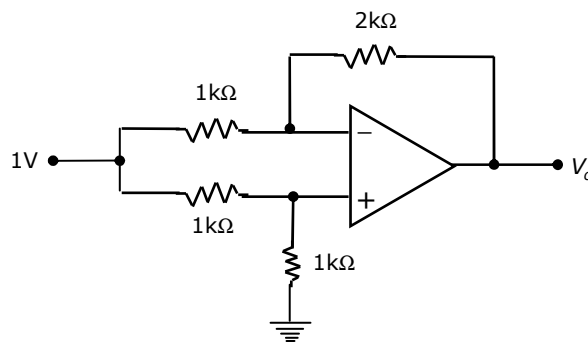

(A) -2 V

(B) -1 V

(C) -0.5 V

(D) 0.5 V

37. For the BJT circuit shown, assume that the  $\beta$  of the transistor is very large and  $V_{BE} = 0.7V$ . The mode of operation of the BJT is:

- (A) cut-off
- (B) saturation
- (C) normal active
- (D) reverse active

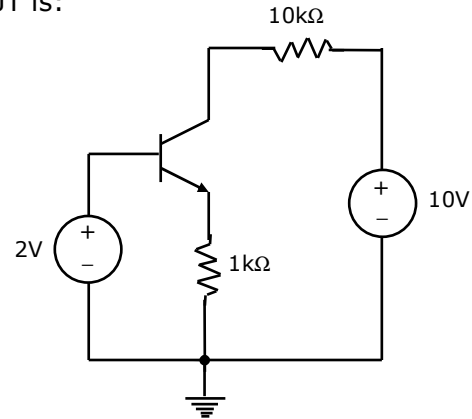

38. In the Op-Amp circuit shown, assume that the diode current follows the equation  $I = I_s \exp(V/V_T)$ . For  $V_i = 2V, V_o = V_{o1}$ , and for  $V_i = 4V, V_o = V_{o2}$ . The relationship between  $V_{o1}$  and  $V_{o2}$  is:

- (A)  $V_{o2} = \sqrt{2}V_{o1}$
- (B)  $V_{o2} = e^2V_{o1}$
- (C)  $V_{o2} = V_{o1} \ln 2$
- (D)  $V_{o1} - V_{o2} = V_T \ln 2$

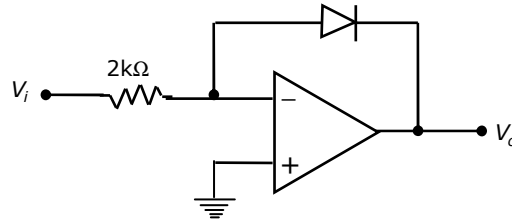

39. In the CMOS inverter circuit shown, if the transconductance parameters of the NMOS and PMOS transistors are  $k_n = k_p = \mu_n C_{ox} \frac{W_n}{L_n} = \mu_p C_{ox} \frac{W_p}{L_p} = 40 \mu A/V^2$  and their threshold voltages are  $V_{THn} = |V_{THp}| = 1V$ , the current I is:

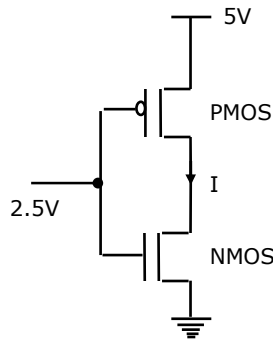

- (A) 0 A
- (B) 25  $\mu A$
- (C) 45  $\mu A$
- (D) 90  $\mu A$

40. For the Zener diode shown in the figure, the Zener voltage at knee is 7V, the knee current is negligible and the Zener dynamic resistance is 10 $\Omega$ . If the input voltage ( $V_i$ ) range is from 10 to 16V, the output voltage ( $V_o$ ) ranges from



- (A) 7.00 to 7.29 V
- (B) 7.14 to 7.29 V
- (C) 7.14 to 7.43 V
- (D) 7.29 to 7.43 V

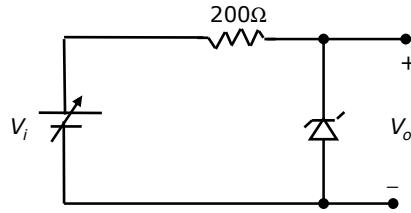

41. The Boolean expression  $Y = \bar{A}\bar{B}\bar{C}D + \bar{A}BC\bar{D} + A\bar{B}\bar{C}D + AB\bar{C}\bar{D}$  can be minimized to

- (A)  $Y = \bar{A}\bar{B}\bar{C}D + \bar{A}B\bar{C} + A\bar{C}D$
- (B)  $Y = \bar{A}\bar{B}\bar{C}D + BC\bar{D} + A\bar{B}\bar{C}D$
- (C)  $Y = \bar{A}BC\bar{D} + \bar{B}\bar{C}D + A\bar{B}\bar{C}D$
- (D)  $Y = \bar{A}BC\bar{D} + \bar{B}\bar{C}D + AB\bar{C}\bar{D}$

42. The circuit diagram of a standard TTL NOT gate is shown in the figure. When  $V_i = 2.5V$ , the modes of operation of the transistors will be:

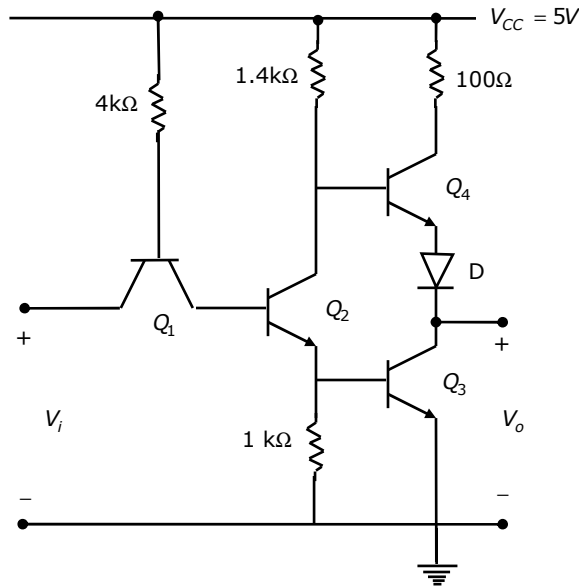

- (A)  $Q_1$  : reverse active;  $Q_2$  : normal active;  $Q_3$  : saturation;  $Q_4$  : cut-off
- (B)  $Q_1$  : reverse active;  $Q_2$  : saturation;  $Q_3$  : saturation;  $Q_4$  : cut-off
- (C)  $Q_1$  : normal active;  $Q_2$  : cut-off;  $Q_3$  : cut-off;  $Q_4$  : saturation
- (D)  $Q_1$  : saturation;  $Q_2$  : saturation;  $Q_3$  : saturation;  $Q_4$  : normal active

43. In the following circuit, X is given by

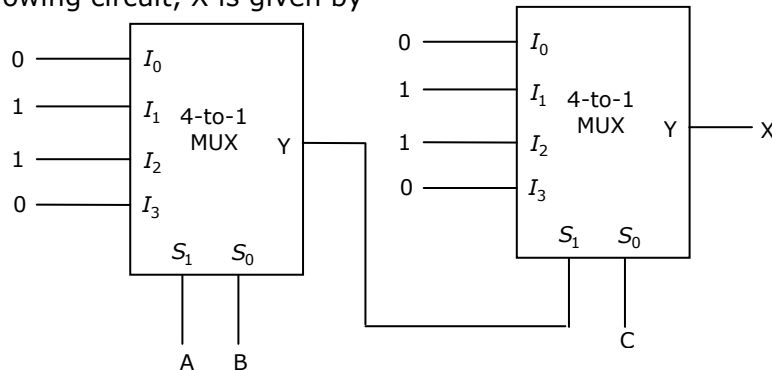

- (A)  $X = A \bar{B} \bar{C} + \bar{A} B \bar{C} + \bar{A} \bar{B} C + A B C$   
 (B)  $X = \bar{A} B C + A \bar{B} C + A B \bar{C} + \bar{A} \bar{B} \bar{C}$   
 (C)  $X = AB + BC + AC$  (D)  $X = \bar{A} \bar{B} + \bar{B} \bar{C} + \bar{A} \bar{C}$

44. The following binary values were applied to the X and Y inputs of the NAND latch shown in the figure in the sequence indicated below:

$X = 0, Y = 1; \quad X = 0, Y = 0; \quad X = 1, Y = 1.$

The corresponding stable P, Q outputs will be:

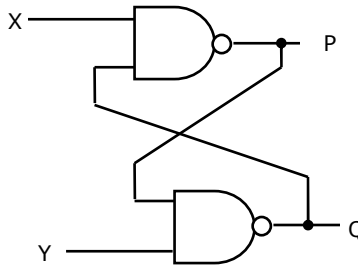

- (A)  $P = 1, Q = 0; \quad P = 1, Q = 0; \quad P = 1, Q = 0$  or  $P = 0, Q = 1$   
 (B)  $P = 1, Q = 0; \quad P = 0, Q = 1; \quad$  or  $P = 0, Q = 1; \quad P = 0, Q = 1$   
 (C)  $P = 1, Q = 0; \quad P = 1, Q = 1; \quad P = 1, Q = 0$  or  $P = 0, Q = 1$   
 (D)  $P = 1, Q = 0; \quad P = 1, Q = 1; \quad P = 1, Q = 1$

45. For the circuit shown, the counter state  $(Q_1Q_0)$  follows the sequence

- (A) 00, 01, 10, 11, 00 ...  
 (B) 00, 01, 10, 00, 01 ...  
 (C) 00, 01, 11, 00, 01 ...  
 (D) 00, 10, 11, 00, 10 ...

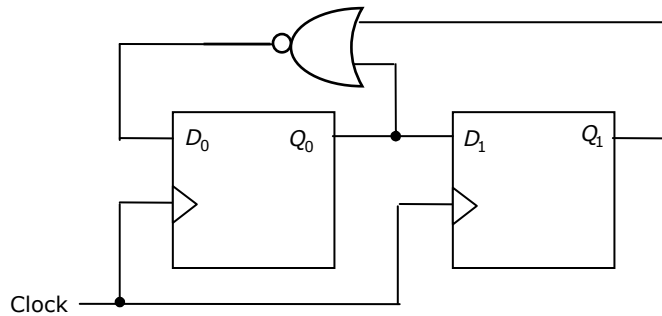

46. An 8255 chip is interfaced to an 8085 microprocessor system as an I/O mapped I/O as shown in the figure. The address lines  $A_0$  and  $A_1$  of the 8085 are used by the 8255 chip to decode internally its three ports and the Control register. The address lines  $A_3$  to  $A_7$  as well as the  $IO/\bar{M}$  signal are used for address decoding. The range of addresses for which the 8255 chip would get selected is:

- (A) F8H – FBH  
 (B) F8H – FCH  
 (C) F8H – FFH  
 (D) F0H – F7H

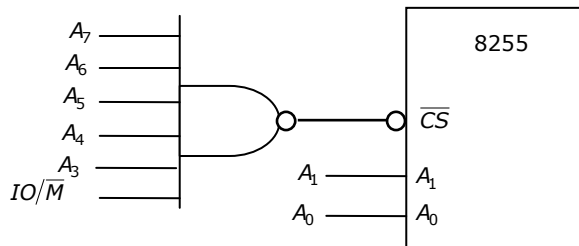

47. The 3-dB bandwidth of the low-pass signal  $e^{-t}u(t)$ , where  $u(t)$  is the unit step function, is given by

- (A)  $\frac{1}{2\pi}$  Hz                      (B)  $\frac{1}{2\pi}\sqrt{\sqrt{2}-1}$  Hz      (C)  $\infty$                       (D) 1 Hz

48. A Hilbert transformer is a

- (A) non-linear system                      (B) non-causal system  
(C) time-varying system                      (D) low-pass system

49. The frequency response of a linear, time-invariant system is given by

$H(f) = \frac{5}{1 + j10\pi f}$ . The step response of the system is:

- (A)  $5(1 - e^{-5t})u(t)$       (B)  $5\left(1 - e^{-\frac{t}{5}}\right)u(t)$       (C)  $\frac{1}{5}(1 - e^{-5t})u(t)$       (D)  $\frac{1}{5}\left(1 - e^{-\frac{t}{5}}\right)u(t)$

50. A 5-point sequence  $x[n]$  is given as

$x[-3] = 1, x[-2] = 1, x[-1] = 0, x[0] = 5, x[1] = 1.$

Let  $X(e^{j\omega})$  denote the discrete-time Fourier transform of  $x[n]$ . The value of

$\int_{-\pi}^{\pi} X(e^{j\omega}) d\omega$  is:

- (A) 5                      (B)  $10\pi$                       (C)  $16\pi$                       (D)  $5 + j10\pi$

51. The z-transform  $X[z]$  of a sequence  $x[n]$  is given by  $X[z] = \frac{0.5}{1 - 2z^{-1}}$ . It is given that the region of convergence of  $X[z]$  includes the unit circle. The value of  $x[0]$  is:

- (A) -0.5                      (B) 0                      (C) 0.25                      (D) 0.5

52. A control system with a PD controller is shown in the figure. If the velocity error constant  $K_v = 1000$  and the damping ratio  $\zeta = 0.5$ , then the values of  $K_p$  and  $K_D$  are:

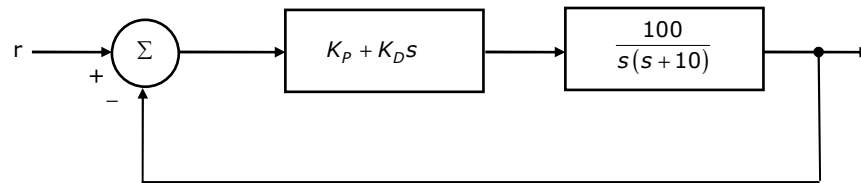

- (A)  $K_p = 100, K_D = 0.09$                       (B)  $K_p = 100, K_D = 0.9$   
(C)  $K_p = 10, K_D = 0.09$                       (D)  $K_p = 10, K_D = 0.9$

53. The transfer function of a plant is  $T(s) = \frac{5}{(s+5)(s^2+s+1)}$ . The second-order approximation of  $T(s)$  using dominant pole concept is:

- (A)  $\frac{1}{(s+5)(s+1)}$       (B)  $\frac{5}{(s+5)(s+1)}$       (C)  $\frac{5}{s^2+s+1}$       (D)  $\frac{1}{s^2+s+1}$

54. The open-loop transfer function of a plant is given as  $G(s) = \frac{1}{s^2-1}$ . If the plant is operated in a unity feedback configuration, then the lead compensator that can stabilize this control system is:

- (A)  $\frac{10(s-1)}{s+2}$       (B)  $\frac{10(s+4)}{s+2}$       (C)  $\frac{10(s+2)}{s+10}$       (D)  $\frac{2(s+2)}{s+10}$

55. A unity feedback control system has an open-loop transfer function  $G(s) = \frac{K}{s(s^2+7s+12)}$ . The gain  $K$  for which  $s = -1 + j1$  will lie on the root locus of this system is:

- (A) 4      (B) 5.5      (C) 6.5      (D) 10

56. The asymptotic Bode plot of a transfer function is as shown in the figure. The transfer function  $G(s)$  corresponding to this Bode plot is:

- (A)  $\frac{1}{(s+1)(s+20)}$   
 (B)  $\frac{1}{s(s+1)(s+20)}$   
 (C)  $\frac{100}{s(s+1)(s+20)}$   
 (D)  $\frac{100}{s(s+1)(1+0.05s)}$

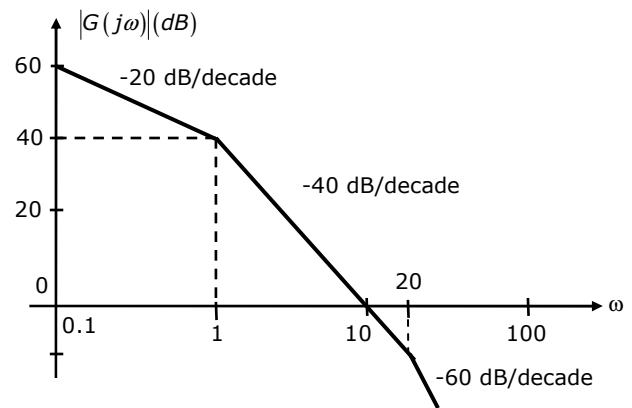

57. The state space representation of a separately excited DC servo motor dynamics is given as

$$\begin{bmatrix} \frac{d\omega}{dt} \\ \frac{di_a}{dt} \end{bmatrix} = \begin{bmatrix} -1 & 1 \\ -1 & -10 \end{bmatrix} \begin{bmatrix} \omega \\ i_a \end{bmatrix} + \begin{bmatrix} 0 \\ 10 \end{bmatrix} u$$

- (A)  $\frac{10}{s^2+11s+11}$       (B)  $\frac{1}{s^2+11s+11}$       (C)  $\frac{10s+10}{s^2+11s+11}$       (D)  $\frac{1}{s^2+s+1}$

58. In delta modulation, the slope overload distortion can be reduced by  
 (A) decreasing the step size (B) decreasing the granular noise  
 (C) decreasing the sampling rate (D) increasing the step size
59. The raised cosine pulse  $p(t)$  is used for zero ISI in digital communications. The expression for  $p(t)$  with unity roll-off factor is given by  $p(t) = \frac{\sin 4\pi Wt}{4\pi Wt(1 - 16W^2t^2)}$ .

The value of  $p(t)$  at  $t = \frac{1}{4W}$  is:

- (A) -0.5 (B) 0 (C) 0.5 (D)  $\infty$
60. In the following scheme, if the spectrum  $M(f)$  of  $m(t)$  is as shown, then the spectrum  $Y(f)$  of  $y(t)$  will be:

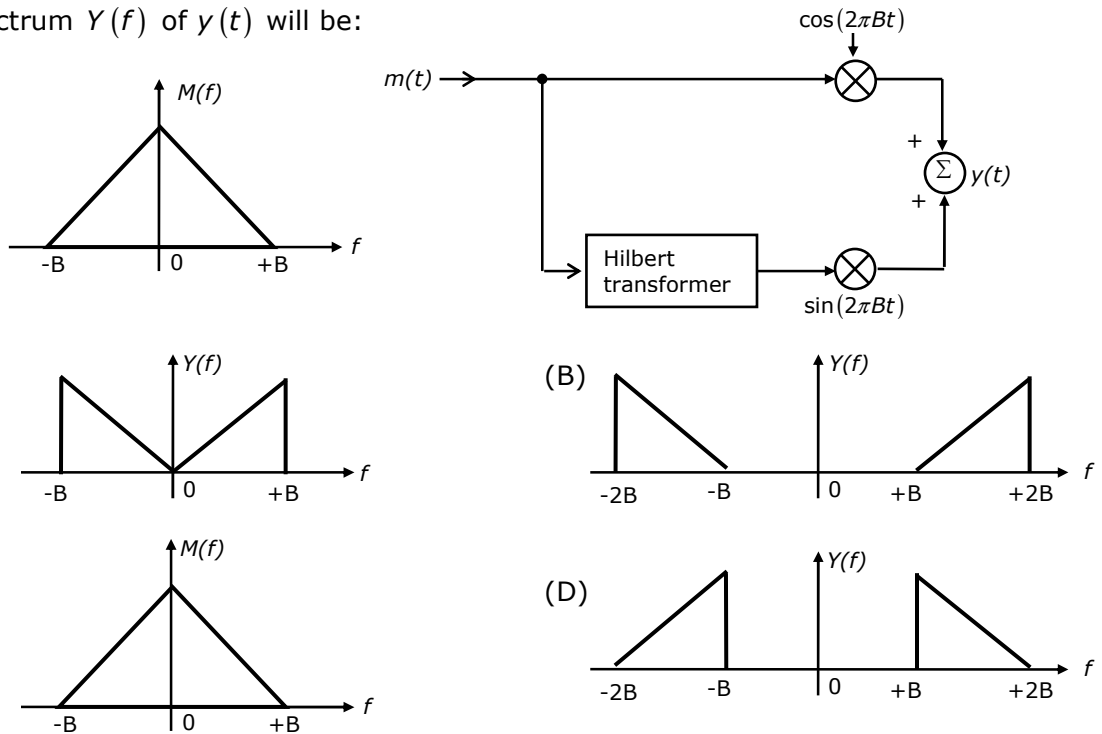

61. During transmission over a certain binary communication channel, bit errors occurs independently with probability  $p$ . The probability of AT MOST one bit in error in a block of  $n$  bits is given by  
 (A)  $p^n$  (B)  $1 - p^n$  (C)  $np(1-p)^{n-1} + (1-p)^n$  (D)  $1 - (1-p)^n$
62. In a GSM system, 8 channels can co-exist in 200 KHz bandwidth using TDMA. A GSM based cellular operator is allocated 5 MHz bandwidth. Assuming a frequency reuse factor of  $\frac{1}{5}$ , i.e. a five-cell repeat pattern, the maximum number of simultaneous channels that can exist in one cell is:  
 (A) 200 (B) 40 (C) 25 (D) 5

63. In a Direct Sequence CDMA system the chip rate is  $1.2288 \times 10^6$  chips per second. If the processing gain is desired to be AT LEAST 100, the data rate
- (A) Must be less than or equal to  $12.288 \times 10^3$  bits per sec  
 (B) Must be greater than  $12.288 \times 10^3$  bits per sec  
 (C) Must be exactly equal to  $12.288 \times 10^3$  bits per sec  
 (D) Can take any value less than  $122.88 \times 10^3$  bits per sec.

64. An air-filled rectangular waveguide has inner dimensions of 3 cm  $\times$  2 cm. The wave impedance of the  $TE_{20}$  mode of propagation in the waveguide at a frequency of 30 GHz is (free space impedance  $\eta_0 = 377\Omega$ )
- (A) 308  $\Omega$                       (B) 355  $\Omega$                       (C) 400  $\Omega$                       (D) 461  $\Omega$

65. The  $\vec{H}$  field (in A/m) of a plane wave propagating in free space is given by
- $$\vec{H} = \hat{x} \frac{5\sqrt{3}}{\eta_0} \cos(\omega t - \beta z) + \hat{y} \frac{5}{\eta_0} \sin\left(\omega t - \beta z + \frac{\pi}{2}\right).$$
- The time average power flow density in Watts is:
- (A)  $\frac{\eta_0}{100}$                       (B)  $\frac{100}{\eta_0}$                       (C)  $50\eta_0^2$                       (D)  $\frac{50}{\eta_0}$

66. The  $\vec{E}$  field in a rectangular waveguide of inner dimensions a  $\times$  b is given by
- $$\vec{E} = \frac{\omega\mu}{h^2} \left(\frac{\pi}{a}\right) H_0 \sin\left(\frac{2\pi x}{a}\right)^2 \sin(\omega t - \beta z) \hat{y}$$
- Where  $H_0$  is a constant, and a and b are the dimensions along the x-axis and the y-axis respectively. The mode of propagation in the waveguide is:
- (A)  $TE_{20}$                       (B)  $TM_{11}$                       (C)  $TM_{20}$                       (D)  $TE_{10}$

67. A load of  $50\Omega$  is connected in shunt in a 2-wire transmission line of  $Z_0 = 50\Omega$  as shown in the figure. The 2-port scattering parameter matrix (S-matrix) of the shunt element is:

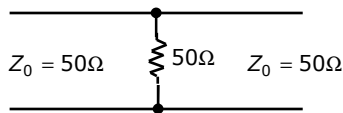

- (A)  $\begin{bmatrix} -\frac{1}{2} & \frac{1}{2} \\ \frac{1}{2} & -\frac{1}{2} \end{bmatrix}$                       (B)  $\begin{bmatrix} 0 & 1 \\ 1 & 0 \end{bmatrix}$                       (C)  $\begin{bmatrix} -\frac{1}{3} & \frac{2}{3} \\ \frac{2}{3} & -\frac{1}{3} \end{bmatrix}$                       (D)  $\begin{bmatrix} \frac{1}{4} & -\frac{3}{4} \\ -\frac{3}{4} & \frac{1}{4} \end{bmatrix}$

68. The parallel branches of a 2-wire transmission line are terminated in  $100\Omega$  and  $200\Omega$  resistors as shown in the figure. The characteristic impedance of the line is  $Z_0 = 50\Omega$  and each section has a length of  $\frac{\lambda}{4}$ . The voltage reflection coefficient  $\Gamma$  at the input is:

- (A)  $-j\frac{7}{5}$
- (B)  $-\frac{5}{7}$
- (C)  $j\frac{5}{7}$
- (D)  $\frac{5}{7}$

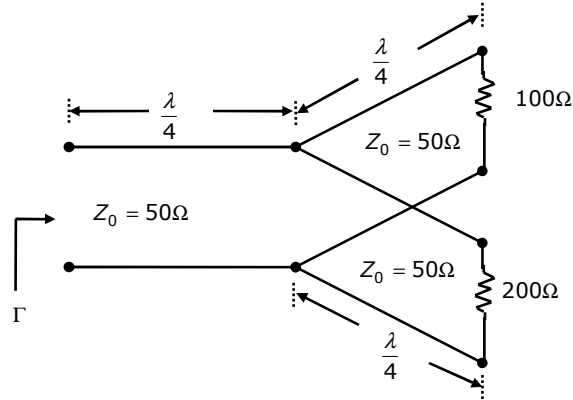

69. A  $\frac{\lambda}{2}$  dipole is kept horizontally at a height of  $\frac{\lambda_0}{2}$  above a perfectly conducting infinite ground plane. The radiation pattern in the plane of the dipole ( $E$  plane) looks approximately as

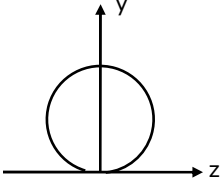
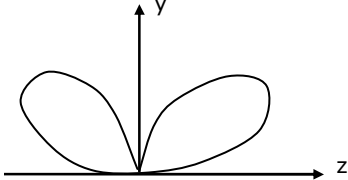
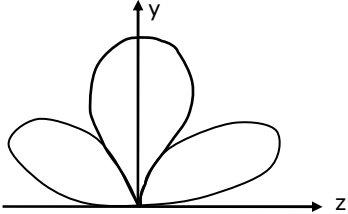
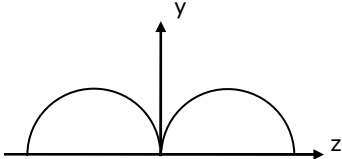
- (A) 
- (B) 
- (C) 
- (D) 

70. A right circularly polarized (RCP) plane wave is incident at an angle of  $60^\circ$  to the normal, on an air-dielectric interface. If the reflected wave is linearly polarized, the relative dielectric constant  $\epsilon_{r2}$  is:

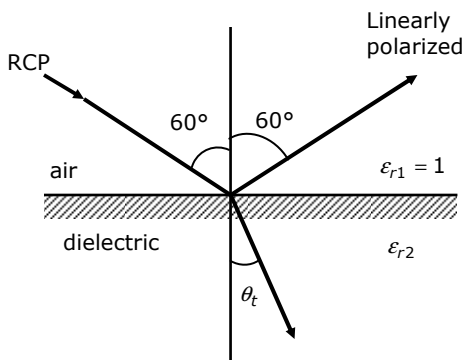

- (A)  $\sqrt{2}$
- (B)  $\sqrt{3}$
- (C) 2
- (D) 3

**Common Data Questions**

**Common Data for Questions 71, 72, 73**

The figure shows the high-frequency capacitance-voltage (C-V) characteristics of a Metal/SiO<sub>2</sub>/silicon (MOS) capacitor having an area of  $1 \times 10^{-4} \text{ cm}^2$ . Assume that the permittivities ( $\epsilon_0 \epsilon_r$ ) of silicon and SiO<sub>2</sub> are  $1 \times 10^{-12} \text{ F/cm}$  and  $3.5 \times 10^{-13} \text{ F/cm}$  respectively.

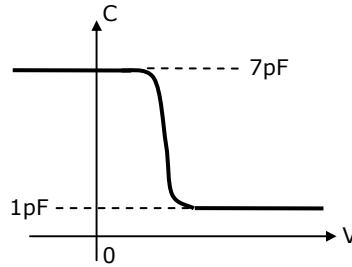

71. The gate oxide thickness in the MOS capacitor is:  
 (A) 50 nm                      (B) 143 nm                      (C) 350 nm                      (D) 1  $\mu\text{m}$
72. The maximum depletion layer width in silicon is  
 (A) 0.143  $\mu\text{m}$                       (B) 0.857  $\mu\text{m}$                       (C) 1  $\mu\text{m}$                       (D) 1.143  $\mu\text{m}$
73. Consider the following statements about the C-V characteristics plot:  
 S1: The MOS capacitor has an *n*-type substrate.  
 S2: If positive charges are introduced in the oxide, the C-V plot will shift to the left.  
 Then which of the following is true?  
 (A) Both S1 and S2 are true                      (B) S1 is true and S2 is false  
 (C) S1 is false and S2 is true                      (D) Both S1 and S2 are false

**Common Data for Questions 74, 75**

Two 4-ray signal constellations are shown. It is given that  $\phi_1$  and  $\phi_2$  constitute an orthonormal basis for the two constellations. Assume that the four symbols in both the constellations are equiprobable. Let  $\frac{N_0}{2}$  denote the power spectral density of white Gaussian noise.

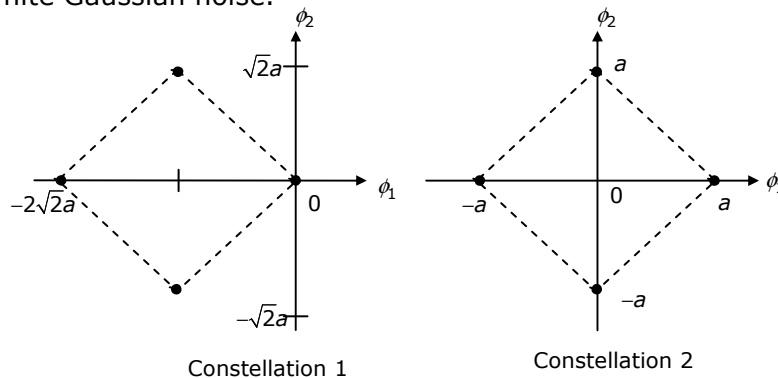



74. The ratio of the average energy of Constellation 1 to the average energy of Constellation 2 is:  
 (A)  $4a^2$                       (B) 4                      (C) 2                      (D) 8
75. If these constellations are used for digital communications over an AWGN channel, then which of the following statements is true?  
 (A) Probability of symbol error for Constellation 1 is lower  
 (B) Probability of symbol error for Constellation 1 is higher  
 (C) Probability of symbol error is equal for both the constellations  
 (D) The value of  $N_0$  will determine which of the two constellations has a lower probability of symbol error.

**Linked Answer Questions: Q.76 to Q.85 Carry Two Marks Each**

**Statement for Linked Answer Questions 76 & 77**

Consider the Op-Amp circuit shown in the figure.

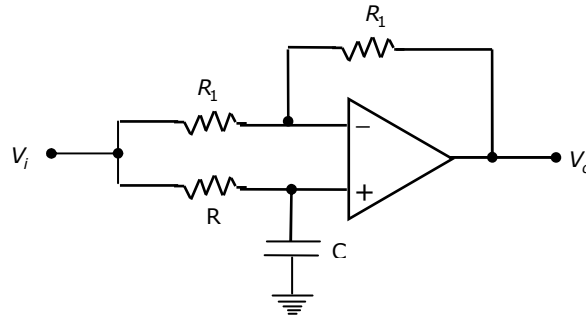

76. The transfer function  $V_o(s)/V_i(s)$  is:  
 (A)  $\frac{1 - sRC}{1 + sRC}$                       (B)  $\frac{1 + sRC}{1 - sRC}$                       (C)  $\frac{1}{1 - sRC}$                       (D)  $\frac{1}{1 + sRC}$
77. If  $V_i = V_1 \sin(\omega t)$  and  $V_o = V_2 \sin(\omega t + \phi)$ , then the minimum and maximum values of  $\phi$  (in radians) are respectively  
 (A)  $-\frac{\pi}{2}$  and  $\frac{\pi}{2}$                       (B) 0 and  $\frac{\pi}{2}$                       (C)  $-\pi$  and 0                      (D)  $-\frac{\pi}{2}$  and 0

**Statement for Linked Answer Questions 78 & 79**

An 8085 assembly language program is given below.

- Line      1: MVI A, B5H  
           2: MVI B, 0EH  
           3: XRI 69H  
           4: ADD B  
           5: ANI 9BH  
           6: CPI 9FH  
           7: STA 3010H  
           8: HLT

78. The contents of the accumulator just after execution of the ADD instruction in line 4 will be  
 (A) C3H (B) EAH (C) DCH (D) 69H
79. After execution of line 7 of the program, the status of the CY and Z flags will be  
 (A) CY = 0, Z = 0 (B) CY = 0, Z = 1 (C) CY = 1, Z = 0 (D) CY = 1, Z = 1

**Statement for Linked Answer Questions 80 & 81**

Consider a linear system whose state space representation is  $\dot{x}(t) = Ax(t)$ . If the initial state vector of the system is  $x(0) = \begin{bmatrix} 1 \\ -2 \end{bmatrix}$ , then the system response is  $x(t) = \begin{bmatrix} e^{-2t} \\ -2e^{-2t} \end{bmatrix}$ . If the initial state vector of the system changes to  $x(0) = \begin{bmatrix} 1 \\ -1 \end{bmatrix}$ , then the system response becomes  $x(t) = \begin{bmatrix} e^{-t} \\ -e^{-t} \end{bmatrix}$ .

80. The eigenvalue and eigenvector pairs  $(\lambda_i, v_i)$  for the system are  
 (A)  $\left(-1, \begin{bmatrix} 1 \\ -1 \end{bmatrix}\right)$  and  $\left(-2, \begin{bmatrix} 1 \\ -2 \end{bmatrix}\right)$  (B)  $\left(-1, \begin{bmatrix} 1 \\ -1 \end{bmatrix}\right)$  and  $\left(2, \begin{bmatrix} 1 \\ -2 \end{bmatrix}\right)$   
 (C)  $\left(-1, \begin{bmatrix} 1 \\ -1 \end{bmatrix}\right)$  and  $\left(-2, \begin{bmatrix} 1 \\ -2 \end{bmatrix}\right)$  (D)  $\left(-2, \begin{bmatrix} 1 \\ -1 \end{bmatrix}\right)$  and  $\left(1, \begin{bmatrix} 1 \\ -2 \end{bmatrix}\right)$
81. The system matrix A is:  
 (A)  $\begin{bmatrix} 0 & 1 \\ -1 & 1 \end{bmatrix}$  (B)  $\begin{bmatrix} 1 & 1 \\ -1 & -2 \end{bmatrix}$  (C)  $\begin{bmatrix} 2 & 1 \\ -1 & -1 \end{bmatrix}$  (D)  $\begin{bmatrix} 0 & 1 \\ -2 & -3 \end{bmatrix}$

**Statement for Linked Answer Questions 82 & 83**

An input to a 6-level quantizer has the probability density function  $f(x)$  as shown in the figure. Decision boundaries of the quantizer are chosen so as to maximize the entropy of the quantizer output. It is given that 3 consecutive decision boundaries are '-1', '0' and '1'.

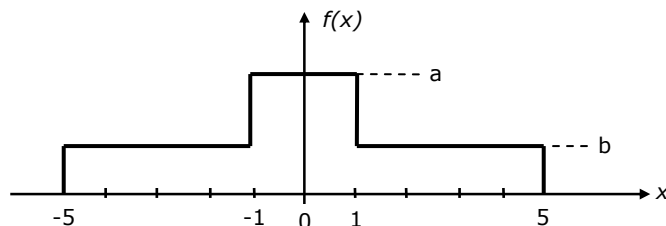

82. The values of  $a$  and  $b$  are:

- (A)  $a = \frac{1}{6}$  and  $b = \frac{1}{12}$                       (B)  $a = \frac{1}{5}$  and  $b = \frac{3}{40}$   
 (C)  $a = \frac{1}{4}$  and  $b = \frac{1}{16}$                       (D)  $a = \frac{1}{3}$  and  $b = \frac{1}{24}$

83. Assuming that the reconstruction levels of the quantizer are the mid-points of the decision boundaries, the ratio of signal power to quantization noise power is:

- (A)  $\frac{152}{9}$                       (B)  $\frac{64}{3}$                       (C)  $\frac{76}{3}$                       (D) 28

**Statement for Linked Answer Questions 84 & 85**

In the Digital-to-Analog converter circuit shown in the figure below,  $V_R = 10$  V and  $R = 10$  k $\Omega$ .

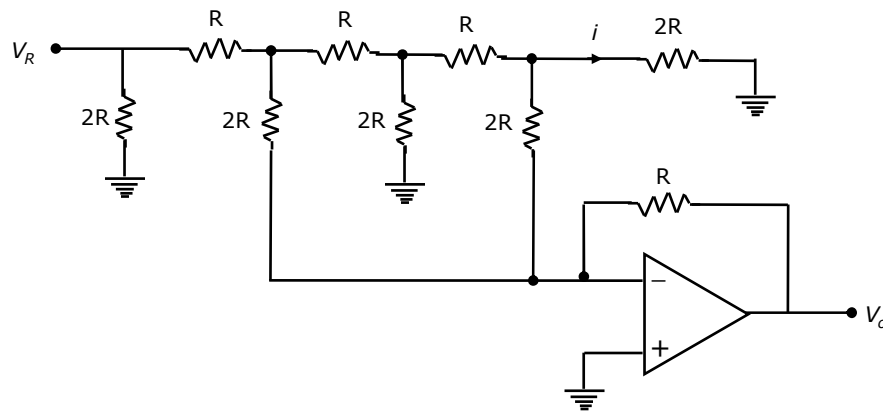

84. The current  $i$  is:

- (A) 31.25  $\mu$ A                      (B) 62.5  $\mu$ A                      (C) 125  $\mu$ A                      (D) 250  $\mu$ A

85. The voltage  $V_o$  is:

- (A) -0.781 V                      (B) -1.562 V                      (C) -3.125 V                      (D) -6.250 V