

- N. B. :** (1) Question No. 1 is compulsory.  
(2) Attempt any four questions out of the remaining six questions.  
(3) Figures to right indicate full marks.  
(4) Assume suitable data if necessary.

1. Attempt any Five of the following:

20

- Compare Butterworth and Chebyshev filters in terms of frequency response and order of the filter.
- State the advantages of switched capacitor filter.
- Compare between FIR and IIR digital filters.
- Explain the working principle of basic Wiener filter.
- Explain in brief any one application of Multirate DSP.
- Write a short note on Quadrature mirror filter (QMF) bank.
- Digitize the analog transfer function using impulse invariance method.

$$H_a(s) = \frac{2}{(s+1)(s+3)}$$

2. a) What is FDNR? State its properties. Explain synthesis of lowpass functions using FDNRs. 10  
with Op-amps
- b) Explain the effect of Decimation and Interpolation in time and frequency domains 10  
with examples.

3. a) Design lowpass FIR linear phase filter with 11 coefficients using Hamming window for the 10  
following specifications.

Passband Frequency : 0.25 KHz

Sampling Frequency : 1 KHz

- b) Design a Butterworth filter using impulse invariance and Bilinear transformation. 10  
for the following specifications. Assume  $T = 1$  sec.

$$0.8 \leq |H(e^{jw})| \leq 1 \quad \text{for} \quad 0 \leq |w| \leq 0.2\pi$$

$$|H(e^{jw})| \leq 0.2 \quad \text{for} \quad 0.6\pi \leq |w| \leq \pi$$

4. a) Explain the design steps of FIR filter using frequency sampling method. Give merits and 10  
demerits over window method.
- b) Design a Chebyshev-I bandstop digital filter with the following specifications: 10

Passband range: 0 to 275 Hz and 2KHz to  $\infty$

Stopband range: 550 Hz to 1000 Hz

Sampling Frequency : 8 KHz

Passband attenuation ( $\alpha_p$ ) = 1 dB.

Stopband attenuation ( $\alpha_s$ ) = 15 dB.

Use BLT and Assume  $T=1$  sec.

5. a) Prove that  $s = \frac{2}{T} \frac{1-z^{-1}}{1+z^{-1}}$  and  $\omega = 2 \tan^{-1} \frac{\Omega T}{2}$  in bilinear transformation. Also explain mapping between s-plane and z-plane. 10
- b) Describe Leapfrog realization technique in detail. 10
6. a) Draw the DTFT spectrums at points  $X_1, X_2, X_3, X_4, X_5, X_6$  shown in Figure below. 10

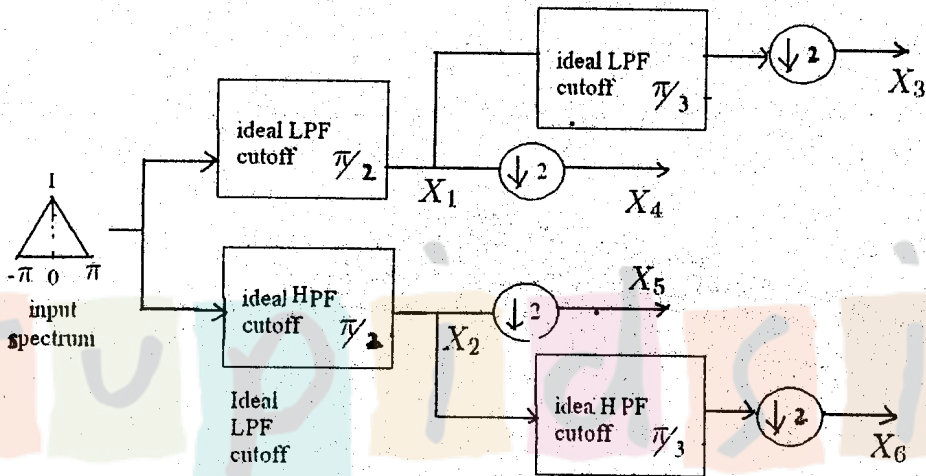

- b) Explain the concept of subband coding. 05
- c) What are conditions that must be imposed on impulse response of FIR filter to obtain linear phase response? Identify which of impulse of the following will give linear phase response? Why? assume 4<sup>th</sup> sample as a origin. 05

$$h_1(n) = (1, 3, 4, 2, 4, 3, 1)$$

$$h_2(n) = (1, 3, 4, 2, 1, 3, 4)$$

7. Write short note on any four:

20

- Kaiser Window
- LMS algorithm
- Frequency Warping effect in BLT
- Applications of adaptive filters
- Lowpass to Bandpass analog frequency transformation
- Matched Z-transform.