

DO NOT OPEN THIS TEST BOOKLET UNTIL YOU ARE ASKED TO DO SO

T.B.C. : O-FTF-J-FUA

Test Booklet Series

Serial No 064949

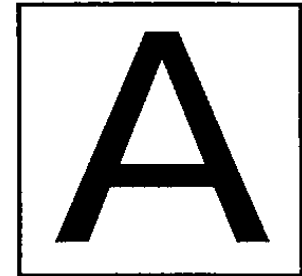

TEST BOOKLET

ELECTRONICS AND TELECOMMUNICATION ENGINEERING

Paper I

Time Allowed : Two Hours

Maximum Marks : 200

INSTRUCTIONS

1. IMMEDIATELY AFTER THE COMMENCEMENT OF THE EXAMINATION, YOU SHOULD CHECK THAT THIS TEST BOOKLET DOES **NOT** HAVE ANY UNPRINTED OR TORN OR MISSING PAGES OR ITEMS ETC. IF SO, GET IT REPLACED BY A COMPLETE TEST BOOKLET.
2. ENCODE CLEARLY THE TEST BOOKLET SERIES A, B, C, OR D AS THE CASE MAY BE IN THE APPROPRIATE PLACE IN THE ANSWER SHEET.
3. You have to enter your Roll Number on the Test Booklet in the Box provided alongside.
DO NOT write *anything else* on the Test Booklet.
4. This Test Booklet contains 120 items (questions). Each item comprises four responses (answers). You will select the response which you want to mark on the Answer Sheet. In case you feel that there is more than one correct response, mark the response which you consider the best. In any case, choose **ONLY ONE** response for each item.
5. You have to mark all your responses **ONLY** on the separate Answer Sheet provided. See directions in the Answer Sheet.
6. All items carry equal marks.
7. Before you proceed to mark in the Answer Sheet the response to various items in the Test Booklet, you have to fill in some particulars in the Answer Sheet as per instructions sent to you with your Admission Certificate.
8. After you have completed filling in all your responses on the Answer Sheet and the examination has concluded, you should hand over to the Invigilator **only the Answer Sheet**. You are permitted to take away with you the Test Booklet.
9. Sheets for rough work are appended in the Test Booklet at the end.
10. **Penalty for wrong answers :**
THERE WILL BE PENALTY FOR WRONG ANSWERS MARKED BY A CANDIDATE IN THE OBJECTIVE TYPE QUESTION PAPERS.
 - (i) There are four alternatives for the answer to every question. For each question for which a wrong answer has been given by the candidate, **one-third (0.33)** of the marks assigned to that question will be deducted as penalty.
 - (ii) If a candidate gives more than one answer, it will be treated as a **wrong answer** even if one of the given answers happens to be correct and there will be same penalty as above to that question.
 - (iii) If a question is left blank, i.e., no answer is given by the candidate, there will be **no penalty** for that question.

DO NOT OPEN THIS TEST BOOKLET UNTIL YOU ARE ASKED TO DO SO

1. Which of the following statements is/are true for the diamond structure ?
- Coordination number is four.
 - Packing fraction is 0.34.
 - Copper crystallizes into diamond structure.
 - Lattice is FCC.
- (a) 1 only
(b) 1, 2 and 4
(c) 2 and 3 only
(d) 2, 3 and 4
2. Which of the following statements is/are true for a good conductor of electricity ?
- Its conductivity decreases with increasing temperature.
 - Number of free electrons is around 10^{28} m^{-3} .
 - Its conductivity decreases with addition of impurities.
 - It is a good conductor of heat also.
- (a) 1, 2, 3 and 4
(b) 1 only
(c) 2 and 3 only
(d) 3 and 4 only
3. Which of the following materials is *not* an insulator ?
- (a) Diamond
(b) Graphite
(c) Bakelite
(d) Lucite
4. Consider the following statements :
The conductivity of a metal has negative temperature coefficient since :
- The electron concentration increases with temperature.
 - The electron mobility decreases with temperature.
 - The electron - lattice scattering rate increases with temperature.
- Which of the above statements is/are correct ?
- (a) 1 only
(b) 1 and 2
(c) 2 and 3
(d) 3 only
5. Which of the following is *not* a conducting material ?
- (a) Copper
(b) Tungsten
(c) Germanium
(d) Platinum
6. What is the chemical bonding in silicon semiconductor ?
- (a) Metallic
(b) Ionic
(c) Covalent
(d) Van der Waals
7. Which one of the following is a trivalent material ?
- (a) Antimony
(b) Phosphorus
(c) Arsenic
(d) Boron

8. The fuse material used in electrical lines must have which one of the following properties ?
- High resistivity
 - Low conductivity
 - High melting point
 - Low melting point
9. Manganin, an alloy of copper and manganese, is used in
- Soldering material
 - Heating elements
 - Ballast resistors
 - Standard resistances
10. Which one of the following pairs is *not* correctly matched ?
- NaCl : Diamagnetic
 - Gd : Paramagnetic
 - Ferrite : Ferrimagnetic
 - Cr₂O₃ : Ferromagnetic
11. Hysteresis loss in a transformer working at 220 V and at a frequency of 50 Hz is 100 W. When the transformer is operated at 220 V and at a frequency of 100 Hz, what is the hysteresis loss ?
- 50 W
 - 100 W
 - 200 W
 - 400 W
12. Which of the following is *not* an electromagnetic device ?
- Hall transducer
 - Transformer
 - Speedometer
 - Eddy current damping device
13. Which one of the following materials is used for making permanent magnets ?
- Steel
 - Carbon
 - Carbon-Steel
 - Graphite
14. What happens when a paramagnetic material is heated above Curie temperature ?
- It becomes diamagnetic
 - It becomes non-magnetic
 - It becomes ferromagnetic
 - It becomes anti-ferromagnetic
15. Ferromagnetic materials show hysteresis in B – H characteristic. As the magnetic field is increased slowly from zero value, what is the first process which sets in the material to give net magnetization ?
- Growth of favourably oriented domains at the cost of other domains by reversible boundary displacements
 - Growth of favourably oriented domains at the cost of other domains by irreversible boundary displacements
 - Domain wall orientation
 - A combination of processes (a) and (c) above
16. The following properties are associated with ferroelectric materials :
- Its susceptibility is negative.
 - The susceptibility is expressed as $\chi = \frac{c}{T - T_c}$ where c is the Curie constant and T_c is the Curie temperature.
 - It has permanent dipoles oriented randomly.
- Which of the above statements is/are correct ?
- 1 only
 - 1 and 3
 - 2 only
 - 1, 2 and 3

17. Consider the following :

1. Si
2. Ge
3. GaAs
4. InP

Which of the above semiconductors should be used for making highly efficient photodiodes ?

- (a) 1 and 4 only
- (b) 3 and 4 only
- (c) 1, 3 and 4
- (d) 2, 3 and 4

18. The materials not having negative temperature coefficient of resistivity are

- (a) Metals
- (b) Semiconductors
- (c) Insulators
- (d) None of the above

19. Which one of the following compounds is widely used for making ferrites ?

- (a) FeO
- (b) CuO
- (c) MgO
- (d) Fe₂O₃

20. Effective Q of the equivalent electrical circuit of quartz crystal is of the order of

- (a) 200
- (b) 2000
- (c) 20,000
- (d) 2,00,000

21. In a material, the Fermi level is located between the centre of the forbidden band and the conduction band. Then what is that material ?

- (a) A p-type semiconductor
- (b) An n-type semiconductor
- (c) An intrinsic semiconductor.
- (d) An insulator

22. Consider the following statements :

1. Acceptor level is formed very close to the conduction band.
2. The effective mass of the free electron is same as that of a hole.
3. The magnitude of the charge of a free electron is same as that of a hole.
4. Addition of donor impurities adds holes to the semiconductor.

Which of the above statements are correct ?

- (a) 1 and 3
- (b) 2 and 3
- (c) 2 and 4
- (d) 3 and 4

23. Diffusion current of holes in a semiconductor is proportional to (with p = concentration of holes / unit volume)

- (a) $\frac{dp}{dx^2}$
- (b) $\frac{dp}{dx}$
- (c) $\frac{dp}{dt}$
- (d) $\frac{d^2p}{dx^2}$

24. The junction capacitance of a linearly graded pn junction (with applied voltage = V_B) is proportional to

- (a) V_B^2
 (b) $V_B^{-\frac{1}{2}}$
 (c) $V_B^{\frac{1}{3}}$
 (d) $V_B^{-\frac{1}{3}}$

25. As per Hall effect, if any specimen carrying a current I is placed in a transverse magnetic field B , then an electric field E is induced in the specimen in the direction

- (a) parallel to I
 (b) perpendicular to B and parallel to I
 (c) parallel to I and B
 (d) perpendicular to both I and B

26. What current does

$$I = Aq \left(\frac{D_p}{L_p N_D} + \frac{D_n}{L_n N_A} \right) n_i^2 \quad \text{represent in}$$

pn junction diode? (where the symbols have their usual meaning)

- (a) Forward current
 (b) Diffusion current
 (c) Drift current
 (d) Reverse saturation current

27. Which of the following quantities **cannot** be measured/determined using Hall effect?

- (a) Type of semiconductor (p or n)
 (b) Mobility of charge carriers
 (c) Diffusion constant
 (d) Carrier concentration

28. A junction FET, can be used as a voltage variable resistor

- (a) at pinch-off condition
 (b) beyond pinch-off voltage
 (c) well below pinch-off condition
 (d) for any value of V_{DS}

29.

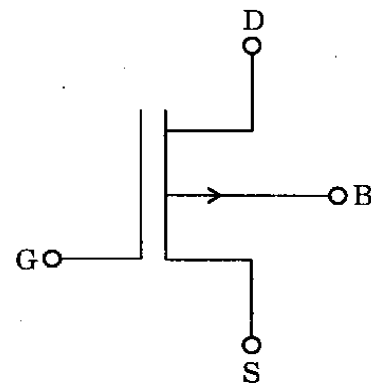

The above figure shows the symbol of

- (a) p channel depletion MOSFET
 (b) p channel enhancement MOSFET
 (c) complementary MOSFET
 (d) p channel JFET

30. The maximum power dissipation capacity of a transistor is 50 mW. If the collector emitter voltage is 10 V, what is the safe collector current that can be allowed through the transistor?

- (a) 5 mA
 (b) 2.5 mA
 (c) 10 mA
 (d) 25 mA

31. Which one of the following statements is correct for MOSFETS ?
- p channel MOS is easier to produce than n channel MOS
 - n channel MOS must have twice the area of p channel MOS for the same ON resistance
 - p channel MOS has faster switching action than n channel MOS
 - p channel MOS has higher packing density than n channel MOS
32. The process of extension of a single-crystal surface by growing a film in such a way that the added atoms form a continuation of the single-crystal structure is called
- Ion implantation
 - Chemical vapour deposition
 - Electroplating
 - Epitaxy
33. The maximum concentration of the element which can be dissolved in solid silicon at a given temperature is termed as
- Solid solubility
 - Dissolution coefficient
 - Solidification index
 - Concentration index
34. Which of the following devices is used in the microprocessors ?
- JFET
 - BJT
 - MOSFET
 - CMOS
35. In a CMOS CS amplifier, the active load is obtained by connecting a
- p channel current mirror circuit
 - n channel transistor
 - p channel transistor
 - BJT current mirror
36. Which one of the following is *not* LED material ?
- GaAs
 - GaP
 - SiC
 - SiO₂
37. The minimum energy of a photon required for intrinsic excitation is equal to
- energy of bottom of conduction band
 - energy of top of valence band
 - forbidden gap energy
 - Fermi energy
38. A signal $x_1(t)$ and $x_2(t)$ constitute the real and imaginary parts respectively of a complex valued signal $x(t)$. What form of waveform does $x(t)$ possess ?
- Real symmetric
 - Complex symmetric
 - Asymmetric
 - Conjugate symmetric

39. A function of one or more variables which conveys information on the nature of physical phenomenon is called

- (a) Noise
- (b) Interference
- (c) System
- (d) Signal

40. The output $y(t)$ of a continuous-time system S for the input $x(t)$ is given by:

$$y(t) = \int_{-\infty}^t x(\lambda) d\lambda$$

Which one of the following is correct ?

- (a) S is linear and time-invariant
- (b) S is linear and time-varying
- (c) S is non-linear and time-invariant
- (d) S is non-linear and time-varying

41. What is the period of the sinusoidal signal $x(n) = 5 \cos [0.2 \pi n]$?

- (a) 10
- (b) 5
- (c) 1
- (d) 0

42. Transfer function of a certain system is

$$\frac{Y(s)}{U(s)} = \frac{1}{s^4 + 5s^3 + 8s^2 + 6s + 3}$$

Which one of the following will be the A, B matrix pair of state variable representation of this system ?

(a)
$$\begin{bmatrix} 0 & 1 & 0 & 0 \\ 0 & 0 & 1 & 0 \\ 0 & 0 & 0 & 1 \\ -3 & -6 & -8 & -5 \end{bmatrix} \begin{bmatrix} 0 \\ 0 \\ 0 \\ 1 \end{bmatrix}$$

(b)
$$\begin{bmatrix} 0 & 1 & 0 & 0 \\ 0 & 0 & 1 & 0 \\ 0 & 0 & 0 & 1 \\ -5 & -8 & -6 & -3 \end{bmatrix} \begin{bmatrix} 0 \\ 0 \\ 0 \\ 1 \end{bmatrix}$$

(c)
$$\begin{bmatrix} 1 & 0 & 0 & 0 \\ 0 & 1 & 0 & 0 \\ 0 & 0 & 1 & 0 \\ -3 & -6 & -8 & -5 \end{bmatrix} \begin{bmatrix} 1 \\ 0 \\ 0 \\ 0 \end{bmatrix}$$

(d)
$$\begin{bmatrix} 0 & 1 & 0 & 0 \\ 0 & 0 & 1 & 0 \\ 0 & 0 & 0 & 1 \\ -3 & -6 & -8 & -5 \end{bmatrix} \begin{bmatrix} 1 \\ 0 \\ 0 \\ 0 \end{bmatrix}$$

43. Separation property of state-transition matrix is

- (a) $\phi(t - t_0) = \phi(t) \phi(t_0)$
- (b) $\phi(t - t_0) = \phi^{-1}(t) \phi^{-1}(t_0)$
- (c) $\phi(t - t_0) = \phi(t) \phi^{-1}(t_0)$
- (d) $\phi(t - t_0) = \phi^{-1}(t) \phi^{-1}(t_0)$

44. When $y(t) \xrightarrow{FT} Y(j\omega)$; $x(t) \xrightarrow{FT} X(j\omega)$;
 $h(t) \xrightarrow{FT} H(j\omega)$. What is $Y(j\omega)$?

- (a) $\frac{X(j\omega)}{H(j\omega)}$
- (b) $X(j\omega) H(j\omega)$
- (c) $X(j\omega) + H(j\omega)$
- (d) $X(j\omega) - H(j\omega)$

45. For a series R-L-C circuit, the characteristic equation is given as

$$s^2 + \frac{R}{L}s + \frac{1}{LC} = 0$$

If $\frac{R}{2L}$ is denoted by α and $\frac{1}{\sqrt{LC}}$ by β , then under the condition of $\beta^2 > \alpha^2$, the system will be

- (a) critically damped
- (b) under damped
- (c) undamped
- (d) over damped

46.

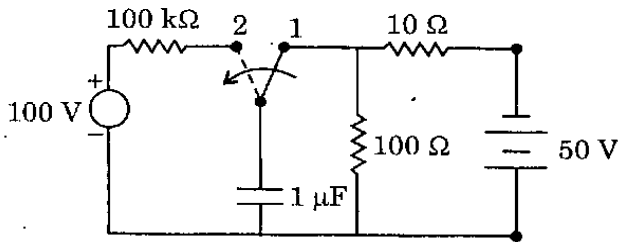

In the above circuit, the switch has been in position 1 for quite a long time. At $t = 0$ the switch is moved to position 2. At this position what is the time constant ?

- (a) 0.1 s
- (b) 1 s
- (c) 0.11 s
- (d) 1.11 s

47.

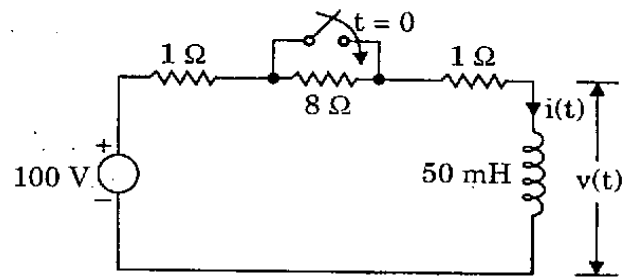

In the above circuit, the switch is open for a long time. At time $t = 0$, the switch is closed. What are the initial and final values of voltages across the inductor ?

- (a) 0 V and 0 V
- (b) 0 V and 80 V
- (c) 80 V and 0 V
- (d) 80 V and 80 V

48. The voltage applied to an R-L circuit at $t = 0$ when switch is closed is $100 \cos(100t + 30^\circ)$. The circuit resistance is 80Ω and inductance is 0.6 H (in which initial current is zero). What is the maximum amplitude of current flowing through the circuit ?

- (a) 1 A
- (b) 2 A
- (c) 5 A
- (d) 10 A

49. A series R-C circuit with $R = 3 \Omega$ and $X_C = 4 \Omega$ at 50 Hz is supplied with a voltage $V = 50 + 141.4 \sin 314t$. What is the RMS value of the current flowing through the circuit ?

- (a) 5 A
- (b) 10 A
- (c) 20 A
- (d) 22.36 A

50.

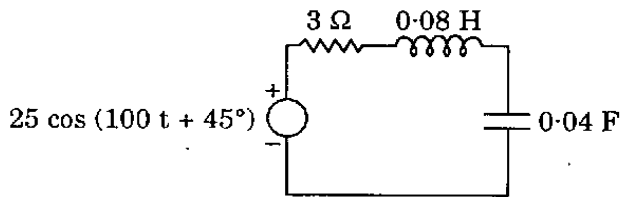

What is the approximate steady state current in the above circuit ?

- (a) 50 A
- (b) 25 A
- (c) 5 A
- (d) 1 A

51. Consider the following statements regarding the properties of an R-L-C series circuit under resonance :

1. Current in the circuit is in phase with applied voltage.
2. Voltage drop across capacitor C and inductance L are equal in magnitude.
3. Voltage across the capacitor is equal in magnitude to the applied voltage.
4. Current in the circuit is maximum.

Which of the above statements is/are correct ?

- (a) 1 only
- (b) 1, 2 and 4
- (c) 2 and 4
- (d) 1, 3 and 4

52.

Which one of the following is applicable to any network — linear or non-linear, active or passive, time-varying or invariant — as long as Kirchoff's laws are *not* violated ?

- (a) Tellegen's theorem
- (b) Reciprocity theorem
- (c) Maximum power transfer theorem
- (d) Superposition theorem

53.

Number of fundamental cut-sets of any graph will be

- (a) same as the number of twigs
- (b) same as the number of tree branches
- (c) same as the number of nodes
- (d) equal to one

54.

If in an electric network R, L and C are connected in series and supplied by a voltage source then its dual network will be described by the differential equation :

- (a) $v(t) = Ri(t) + L \frac{di(t)}{dt} + \frac{1}{C} \int i(t) dt$
- (b) $v(t) = \frac{1}{G} i(t) + C \frac{di(t)}{dt} + \frac{1}{L} \int i(t) dt$
- (c) $i(t) = Gv(t) + C \frac{dv(t)}{dt} + \frac{1}{L} \int v(t) dt$
- (d) $v(t) = Ri(t) + L \frac{di(t)}{dt} + C \int i(t) dt$

55.

In a network with twelve circuit elements and five nodes, what is the minimum number of mesh equations ?

- (a) 24
- (b) 12
- (c) 10
- (d) 8

56. With respect to transmission parameters, which one of the following is correct ?

- (a) A and B are dimensionless
- (b) B and C are dimensionless
- (c) A and D are dimensionless
- (d) B and D are dimensionless

57. Match List I with List II and select the correct answer using the code given below the lists :

List I
(Network parameter)

List II
(Measured under open-circuit conditions)

- | | |
|-------------|---|
| A. Z_{11} | 1. $\left. \frac{V_2}{I_2} \right _{I_1=0}$ |
| B. A | 2. $\left. \frac{V_1}{V_2} \right _{I_2=0}$ |
| C. C | 3. $\left. \frac{V_1}{I_1} \right _{I_2=0}$ |
| D. Z_{22} | 4. $\left. \frac{I_1}{V_2} \right _{I_2=0}$ |

Code :

- | | A | B | C | D |
|-----|---|---|---|---|
| (a) | 1 | 4 | 2 | 3 |
| (b) | 3 | 4 | 2 | 1 |
| (c) | 1 | 2 | 4 | 3 |
| (d) | 3 | 2 | 4 | 1 |

58. Which one of the following driving point functions does *not* represent an LC network ?

(a) $Z(s) = \frac{s(s+3)}{(s^2+1)(s^2+9)}$

(b) $Z(s) = \frac{(s^2+25)}{s(s^2+36)}$

(c) $Z(s) = \frac{(s^2+1)(s^2+36)}{s(s^2+4)(s^2+25)}$

(d) $Z(s) = \frac{s(s^2+16)}{(s^2+25)}$

59. If a two-port network is reciprocal as well as symmetrical, which one of the following relationships is correct ?

(a) $Z_{12} = Z_{21}$ and $Z_{11} = Z_{22}$

(b) $Y_{12} = Y_{21}$ and $Y_{11} = Y_{22}$

(c) $AD - BC = 1$ and $A = D$

(d) All of the above

60. If the connection of two two-ports is such that the transmission matrix of the overall network is the product of the transmission matrices of the individual networks, what type of connection is it ?

(a) Series connection

(b) Cascade connection

(c) Parallel connection

(d) None of the above

61.

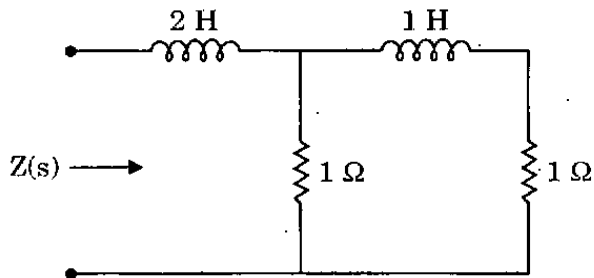

Consider the above network. Impedance of this network as a function of the complex frequency s consists of a certain number of zeros and poles. What is the location of poles ?

- (a) -2
- (b) $-2, \infty$
- (c) 2
- (d) $2, \infty$

62. Consider the following network function

$$N(s) = \frac{s(s+2)}{(s+4)(s+1+j1)(s+1-j1)}$$

In order to make $N(s)$ as rational network function, it is essential to include

- (a) Zero at origin
- (b) Zero at infinity
- (c) Pole at origin
- (d) Pole at infinity

63. For determining the network functions of a two-port network, it is required to consider that

- (a) all initial conditions remain same
- (b) all initial conditions are zero
- (c) part of initial conditions are equal to zero
- (d) initial conditions vary depending on nature of network

64.

All poles and zeros of a driving point immittance function of an L-C network

- (a) should lie on the $j\omega$ axis
- (b) should lie on the +ve real axis
- (c) should lie on the -ve real axis
- (d) can lie anywhere in s-plane

65.

In the field of a charge Q at the origin, the potentials at $A(2, 0, 0)$ and $B(1/2, 0, 0)$ are $V_A = 15$ volt and $V_B = 30$ volt respectively. What will be the potential at $C(1, 0, 0)$?

- (a) 25 volt
- (b) 22.5 volt
- (c) 20 volt
- (d) 17.5 volt

66.

What will be the equipotential surfaces for a pair of equal and opposite line charges ?

- (a) Spheres
- (b) Concentric cylinders
- (c) Non-concentric cylinders
- (d) None of the above

67.

If the potential functions V_1 and V_2 satisfy Laplace's equation within a closed region and assume the same values on its surface, then which of the following is correct ?

- (a) V_1 and V_2 are identical
- (b) V_1 is inversely proportional to V_2
- (c) V_1 has the same direction as V_2
- (d) V_1 has the same magnitude as V_2 but has different direction

68. If $V = \sinh x \cdot \cos ky \cdot e^{pz}$ is a solution of Laplace's equation, what will be the value of k ?
- (a) $\frac{1}{\sqrt{1+p^2}}$
- (b) $\sqrt{1+p^2}$
- (c) $\frac{1}{\sqrt{1-p^2}}$
- (d) $\sqrt{1-p^2}$
69. By what name is the equation $\nabla \cdot \vec{J} = 0$ frequently known ?
- (a) Poisson's equation
- (b) Laplace's equation
- (c) Continuity equation for steady currents
- (d) Displacement equation
70. Method of images is applicable to which fields ?
- (a) Electrostatic fields only
- (b) Electrodynanic fields only
- (c) Neither electrostatic fields nor electrodynamic fields
- (d) Both electrostatic fields and electrodynamic fields
71. Who developed the concept of time varying electric field producing a magnetic field ?
- (a) Gauss
- (b) Faraday
- (c) Hertz
- (d) Maxwell
72. A single turn loop is situated in air, with a uniform magnetic field normal to its plane. The area of the loop is 5 m^2 and the rate of change of flux density is $2 \text{ Wb/m}^2/\text{s}$. What is the emf appearing at the terminals of the loop ?
- (a) -5 V
- (b) -2 V
- (c) -0.4 V
- (d) 0 V
73. Which of the following equations results from the circuital form of Ampere's law ?
- (a) $\nabla \times \vec{E} = -\frac{\partial \vec{B}}{\partial t}$
- (b) $\nabla \cdot \vec{B} = 0$
- (c) $\nabla \cdot \vec{D} = \rho$
- (d) $\nabla \times \vec{H} = \vec{J} + \frac{\partial \vec{D}}{\partial t}$
74. In which direction is the plane wave $\vec{E} = 50 \sin(10^8 t + 2z) \hat{a}_y \text{ V/m}$, (where \hat{a}_y is the unit vector in y-direction), travelling ?
- (a) along y direction
- (b) along $-y$ direction
- (c) along z direction
- (d) along $-z$ direction

75. For parallel plane waveguides, which is the mode with lowest cut-off frequency ?

- (a) TE_{10}
- (b) TM_{10}
- (c) TEM
- (d) TE_{11}

76. For plane wave propagating in free space or two conductor transmission line, what must be the relationship between the phase velocity v_p , the group velocity v_g and speed of light c ?

- (a) $v_p > c > v_g$
- (b) $v_p < c < v_g$
- (c) $v_p = c = v_g$
- (d) $v_p < v_g < c$

77. The reflection coefficient on a 500 m long transmission line has a phase angle of -150° . If the operating wavelength is 150 m, what will be the number of voltage maxima on the line ?

- (a) 0
- (b) 3
- (c) 6
- (d) 7

78. Consider the following statements :

For a 10 m long common power line connecting a switch to a light bulb

1. It is a distributed circuit.
2. Time delay for propagation through it is negligible.
3. It is in the form of a shielded coaxial cable of circular cross-section.
4. As the intensity of the lamp varies, input impedance of this line also changes.

Which of the above statements is/are correct ?

- (a) 1 only
- (b) 1 and 2
- (c) 2 and 3
- (d) 2 and 4

79. With regard to a transmission line, which of the following statements is correct ?

- (a) Any impedance repeats itself every $\lambda/4$ on the Smith chart.
- (b) The S.W.R. = 2 circle and the magnitude of reflection coefficient = 0.5 circle coincide on the Smith chart.
- (c) At any point on a transmission line, the current reflection coefficient is the reciprocal of the voltage reflection coefficient.
- (d) Matching eliminates the reflected wave between the source and the matching device location.

80. Consider the following statements :

In a microstrip line

1. Wavelength $\Lambda = \frac{\lambda}{\epsilon_{ff}}$, where ϵ_{ff} is the effective dielectric constant and λ is the free space wavelength.
2. Electromagnetic fields exist partly in the air above the dielectric substrate and partly within the substrate itself.
3. The effective dielectric constant is greater than the dielectric constant of the air.
4. Conductor losses increase with decreasing characteristic impedance.

Which of the above statements is/are correct ?

- (a) 1, 2 and 3
- (b) 1 and 2 only
- (c) 2, 3 and 4
- (d) 4 only

81. It is required to match a 200Ω load to a 450Ω transmission line. To reduce the SWR along the line to 1, what must be the characteristic impedance of the quarter-wave transformer used for this purpose, if it is connected directly to the load ?

- (a) $90 \text{ k}\Omega$
- (b) 300Ω
- (c) $\frac{9}{4} \Omega$
- (d) $\frac{3}{2} \Omega$

82. The load end of a quarter wave transformer gets disconnected thereby causing an open-circuited load. What will be the input impedance of the transformer ?

- (a) Zero
- (b) Infinite
- (c) Finite and Positive
- (d) Finite and Negative

83. Match List I with List II and select the correct answer using the code given below the lists :

<i>List I</i> (Types of transmission structure)	<i>List II</i> (Modes of propagation)
A. Strip line	1. Quasi TEM
B. Hollow rectangular waveguide	2. Pure TEM
C. Microstrip	3. TE / TM
D. Corrugated waveguide	4. Hybrid

Code :

	A	B	C	D
(a)	2	1	3	4
(b)	4	1	3	2
(c)	2	3	1	4
(d)	4	3	1	2

84. A standard waveguide WR90 has inside wall dimensions of $a = 2.286 \text{ cm}$ and $b = 1.016 \text{ cm}$. What is the cut-off wavelength for TE_{01} mode ?

- (a) 4.572 cm
- (b) 2.286 cm
- (c) 2.032 cm
- (d) 1.857 cm

85. When a particular mode is excited in a waveguide, there appears an extra electric component, in the direction of propagation. In what mode is the wave propagating ?

- (a) Transverse electric
- (b) Transverse magnetic
- (c) Transverse electromagnetic
- (d) Longitudinal

86.

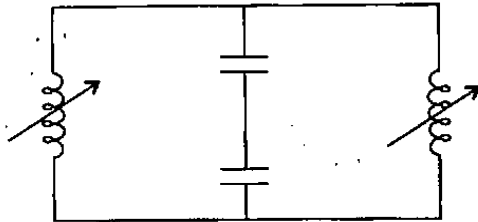

The above shown circuit is the equivalent circuit of which one of the following microwave resonator types ?

- (a) Butterfly resonator
- (b) Parallel-wire resonator
- (c) Cavity resonator
- (d) Coaxial line resonator

87. Which is the dominant mode in rectangular waveguides ?

- (a) TE_{10}
- (b) TE_{11}
- (c) TM_{01}
- (d) TM_{11}

88. Consider the following statements :

For a square waveguide of cross-section $3\text{ m} \times 3\text{ m}$ it has been found

1. At 6 GHz dominant mode will propagate.
2. At 4 GHz all the modes are evanescent.
3. At 11 GHz only dominant modes and no higher order mode will propagate.
4. At 7 GHz degenerate modes will propagate.

Which of the above statements are correct ?

- (a) 1 and 2 only
- (b) 1, 2 and 4
- (c) 2 and 3 only
- (d) 2, 3 and 4

89. Match List I with List II and select the correct answer using the code given below the lists :

List I
(Modes)

List II
(Characteristic)

- | | |
|----------------------------|---|
| A. Evanescent mode | 1. Rectangular waveguide does not support |
| B. Dominant mode | 2. No wave propagation |
| C. TM_{10} and TM_{01} | 3. Lowest cut-off frequency |

Code :

- | | A | B | C |
|-----|---|---|---|
| (a) | 1 | 2 | 3 |
| (b) | 2 | 3 | 1 |
| (c) | 1 | 3 | 2 |
| (d) | 2 | 1 | 3 |

90. Multiple member of antennas are arranged in arrays in order to enhance what property ?

- (a) Both directivity and bandwidth
- (b) Only directivity
- (c) Only bandwidth
- (d) Neither directivity nor bandwidth

91. Consider the following statements regarding an antenna :
1. It is a transducer.
 2. Its performance is essentially frequency sensitive.
 3. It is a reciprocal device.
 4. With increase in its effective aperture area, width of the radiated beam increases.
- Which of the above statements are correct ?
- (a) 1, 2 and 3
 - (b) 1, 2 and 4
 - (c) 2 and 3 only
 - (d) 1 and 4 only
92. What is the minimum value of VSWR that may exist on a transmission line ?
- (a) Less than zero
 - (b) Zero
 - (c) One
 - (d) 10
93. For a second order instrument, the optimum range of ξ (damping ratio), which gives good frequency response over a wide range of frequencies is
- (a) 0.5 to 0.6
 - (b) 0.6 to 0.7
 - (c) 0.7 to 0.8
 - (d) 0.8 to 1.0
94. The Wheatstone bridge method of measuring resistance is ideally suited for the measurement of resistance values in the range of
- (a) 0.001 to 1 Ω
 - (b) 0.1 to 100 Ω
 - (c) 100 Ω to 10 k Ω
 - (d) 100 k Ω to 10 M Ω
95. What is the major cause of creeping in an energy-meter ?
- (a) Over compensation for friction
 - (b) Mechanical vibrations
 - (c) Excessive voltage across the potential coil
 - (d) Stray magnetic fields
96. A compensated wattmeter has its reading corrected for error due to which one of the following parameters ?
- (a) Frequency
 - (b) Friction
 - (c) Power consumed in current coil
 - (d) Power consumed in pressure coil
97. Which of the following bridges is also used in an oscillator ?
- (a) Maxwell
 - (b) Schering
 - (c) Hay
 - (d) Wien

98. Which of the following meters *cannot* measure a.c. quantities ?
- Thermocouple
 - Hot wire
 - P.M.M.C.
 - Electrodynamometer
99. Which of the following meters requires an external power source for its operation ?
- P.M.M.C. meter
 - Hot wire ammeter
 - Electronic voltmeter
 - Electrodynamometer
100. Which of the following statements is *not* correct for thermistors ?
- They have negative temperature coefficient of resistance.
 - The sensing element is made of sintered ceramics, which are oxides of metals in the form of beads.
 - The variation of resistance with temperature is linear.
 - The resistance value at ambient temperature may range from 100Ω to $100 \text{ k}\Omega$.
101. Which of the following devices is used at the first stage of an electronic voltmeter ?
- BJT
 - SCR
 - MOSFET
 - UJT
102. Consider the following statements regarding sources of error in a Q-meter :
- If a coil with resistance R is connected in direct measurement mode and if the residual resistance of Q-meter is $0.1 R$, then the measure Q of the coil would be 1.1 times the actual Q .
 - If the inductance to be measured is less than 0.1 mH , the error due to presence of residual inductance cannot be neglected.
 - The presence of distributed capacitance in a coil modifies the effective Q of the coil.
- Which of the above statements are correct ?
- 1, 2 and 3
 - 1 and 2 only
 - 2 and 3 only
 - 1 and 3 only
103. What is an advantage of an electronic voltmeter over a non-electronic voltmeter ?
- Low power consumption
 - Low input impedance
 - The ability to measure wide ranges of voltages and resistances
 - Large portability

104. An average response rectifier type electronic voltmeter has a d.c. voltage of 10 V applied to it. What is the meter reading ?
- (a) 7.1 V
 - (b) 10 V
 - (c) 11.1 V
 - (d) 22.2 V
105. Which one of the following oscillators is used for the generation of high frequencies ?
- (a) R-C phase shift oscillator
 - (b) Wien bridge oscillator
 - (c) L-C oscillator
 - (d) Blocking oscillator
106. Which of the following transducers requires a high input impedance preamplifier for proper measurements ?
- (a) Thermocouple
 - (b) Piezoelectric
 - (c) Thermistor
 - (d) L.V.D.T.
107. In a digital voltmeter the oscillator frequency is 400 kHz and the ramp voltage falls from 8 V to 0 V in 20 ms. What is the number of pulses counted by the counter ?
- (a) 800
 - (b) 2000
 - (c) 4000
 - (d) 8000
108. Which of the following *cannot* provide as much time interval accuracy as the oscilloscope but can capture and display eight or more signals simultaneously, something that scopes cannot do ?
- (a) Logic analyzer
 - (b) Digital oscilloscope
 - (c) Frequency analyzer
 - (d) Wave analyzer
109. Which of the following transducers is most suitable for monitoring continuous variations in very fine thickness of a material ?
- (a) Diaphragm
 - (b) Capacitor
 - (c) L.V.D.T.
 - (d) Piezoelectric crystal
110. Consider the following statements about ultrasonic flowmeters :
1. The measurement is insensitive to viscosity, pressure and temperature variations.
 2. It has bidirectional measuring capability and can be used for any pipe size.
 3. It has a relatively lower cost.
 4. It has good accuracy, fast response and wide frequency range.
- Which of the above statements is/are correct ?
- (a) 1 only
 - (b) 1 and 2 only
 - (c) 1, 2 and 4
 - (d) 3 and 4 only

Directions : Each of the next ten (10) items consists of two statements, one labelled as the 'Assertion (A)' and the other as 'Reason (R)'. You are to examine these two statements carefully and select the answers to these items using the codes given below :

Codes :

- (a) Both A and R are individually true and R is the correct explanation of A
- (b) Both A and R are individually true but R is **not** the correct explanation of A
- (c) A is true but R is false
- (d) A is false but R is true

111. **Assertion (A) :** An unbiased p-n junction develops a built-in potential at the junction with the n-side positive and the p-side negative.

Reason (R) : The p-n junction behaves as a battery and supplies current to a resistance connected across its terminals.

112. **Assertion (A) :** Cut-in voltage for Germanium diode is greater than that for Silicon diode.

Reason (R) : Germanium diode has a higher reverse saturation current than Silicon diode.

113. **Assertion (A) :** The h-parameter model of a BJT can be derived from its hybrid- π model and vice-versa.

Reason (R) : The hybrid- π model has many more additional elements as compared to h-parameter model of the BJT.

114. **Assertion (A) :** For same drain current rating N-channel MOSFET occupies more area than p-channel MOSFET.

Reason (R) : Electron mobility is much higher than hole mobility.

115. **Assertion (A) :** There are no convergence issues with the discrete-time Fourier series in general.

Reason (R) : A discrete-time signal is always obtained by sampling a continuous-time signal.

116. **Assertion (A) :** Ideal current sources and ideal voltage sources do not exist in reality.

Reason (R) : All sources have finite internal impedances.

117. *Assertion (A)* : Capacitance of a solid conducting spherical body of radius 'a' is given by $4\pi\epsilon_0 a$ in free space.

Reason (R) : $\nabla \times \mathbf{H} = j\omega\epsilon\mathbf{E} + \mathbf{J}$

118. *Assertion (A)* : The expression $\mathbf{E} = -\nabla V$, where \mathbf{E} is the electric field and V is the potential is not valid for time varying fields.

Reason (R) : The curl of a gradient is identically zero.

119. *Assertion (A)* : A z-directed rectangular waveguide with cross-sectional dimensions 3 cm \times 1 cm will support propagation at 4 GHz.

Reason (R) : $k_z^2 + \left(\frac{m\pi}{3}\right)^2 + \left(\frac{n\pi}{1}\right)^2 = \left(\frac{2\pi}{\lambda}\right)^2$

where λ is the wavelength.

120. *Assertion (A)* : As the length of the resonant antenna is increased, the number of lobes increases and the direction of the major lobes is closer and closer to the direction of the dipole.

Reason (R) : As the length increases, the current distribution along the wire becomes more and more uniform.

SPACE FOR ROUGH WORK

SPACE FOR ROUGH WORK

SPACE FOR ROUGH WORK

SPACE FOR ROUGH WORK