



ENGINEERING & MANAGEMENT EXAMINATIONS, DECEMBER - 2007

CONTROL SYSTEM

SEMESTER - 5

Time : 3 Hours]

[Full Marks : 70

Semi-log and graph sheets are printed at the end of this booklet.

GROUP - A

(Multiple Choice Type Questions)

1. Choose the correct alternatives for any ten of the following : 10 × 1 = 10
- i) The characteristic equation of a second order system is $s^2 + 6s + 25 = 0$. The system is
- | | | |
|----------------|-----------------------|--------------------------|
| a) underdamped | b) overdamped | |
| c) undamped | d) critically damped. | <input type="checkbox"/> |
- ii) The type number of a transfer function denotes the number of
- | | | |
|----------------------|--------------------|--------------------------|
| a) poles at origin | b) zeros at origin | |
| c) poles at infinity | d) none of these. | <input type="checkbox"/> |
- iii) Presence of non-linearities in a control system leads to introduce
- | | | |
|-----------------------|------------------|--------------------------|
| a) transient error | b) instability | |
| c) steady state error | d) all of these. | <input type="checkbox"/> |
- iv) In terms of Bode plot, the system is stable if
- | | | |
|--------------------------------|---------------------------------|--------------------------|
| a) PM = GM | b) PM & GM both are positive | |
| c) PM and GM both are negative | d) PM negative but GM positive. | <input type="checkbox"/> |
- v) By the use of PD control to the second order system, the rise time
- | | | |
|-----------------|-------------------|--------------------------|
| a) decreases | b) increases | |
| c) remains same | d) none of these. | <input type="checkbox"/> |



vi) The lead-lag compensation will improve

- a) transient response
 b) transient response and steady state response
 c) none of these.

vii) The response of a control system, having damping factor as unity will be

- a) oscillatory
 b) underdamped
 c) critically damped
 d) none of these.

viii) A system has a single pole at origin. Its impulse response will be

- a) constant
 b) ramp
 c) decaying exponentially
 d) oscillatory.

ix) The matrix shown below is

$$\begin{bmatrix} 4 & -4 & 2 \\ -4 & 5 & -2 \\ 2 & -2 & 1 \end{bmatrix}$$

- a) positive definite
 b) positive semi-definite
 c) negative definite
 d) none of these.

x) A is an $n \times n$ matrix. Then the system to be controllable, the rank of the controllability matrix should be

- a) n
 b) $> n$
 c) $\geq n$
 d) $\leq n$.

xi) The settling time for a second order system responding to a step input with 5% overshoot is

- a) $4/\xi W_n$
 b) $2/\xi W_n$
 c) $3/\xi W_n$
 d) $5/\xi W_n$.

xii) Area under a unit impulse function is

- a) infinity
 b) zero
 c) unity
 d) none of these.



GROUP - B

(Short Answer Type Questions)

Answer any three of the following.

3 × 5 = 15

2. Obtain state variable model of the system whose transfer function is given by

$$\frac{Y(s)}{U(s)} = \frac{s+1}{s^3+3s^2+7s+1}$$

3. Determine the transfer function of an armature control d.c. motor system.

4. A feedback control system is described as

$$G(s) = \frac{50}{s(s+2)(s+5)}, H(s) = \frac{1}{s}$$

Evaluate the static error constants K_p , K_v & K_a for the system.

5. Consider the system

$$\dot{x}_1 = -x_2 + \alpha x_1^3$$

$$\dot{x}_2 = x_1 + \alpha x_2^3$$

Discuss the stability in the sense of Lyapunov.

6. Find C/R using block diagram reduction method of the following diagram :

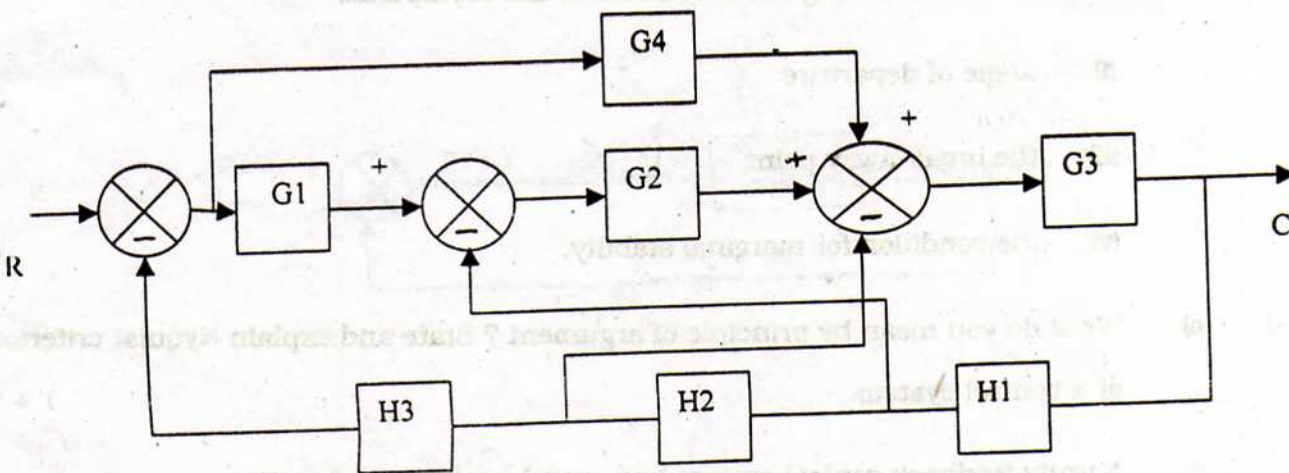

**GROUP - C****(Long Answer Type Questions)**Answer any *three* of the following questions.

3 × 15 = 45

7. a) Mention the difficulties that may arise in applying Routh stability criterion. What do you mean by relative stability ? 2 + 1

- b) The open loop transfer function of a unity feedback control system is given by

$$G(s) = \frac{K(s+1)}{2s^3 + as^2 + 2s + 1}$$

The above system oscillates with frequency ω , if it has poles on $s = +j\omega$ and $s = -j\omega$ and no poles in the right half s -plane. Determine the values of K and a , so that the system oscillates at a frequency of 2 radian/sec. 6

- c) The open loop transfer function of a unity feedback control system is given by

$$G(s) = \frac{K}{s(s^2 + 6s + 25)}$$

Find :

- i) the number, angle and centroid of the asymptotes
 - ii) angle of departure
 - iii) the break-away point
 - iv) the condition for marginal stability. 6
8. a) What do you mean by principle of argument ? State and explain Nyquist criterion of a control system. 1 + 2

- b) A unity feedback control system has open loop transfer function,

$$G(s)H(s) = \frac{(4s+1)}{s^2(s+1)(2s+1)}$$

Determine closed loop stability by Nyquist plot. 7



- c) Determine the transfer function of the system whose Bode plot is shown below : 5

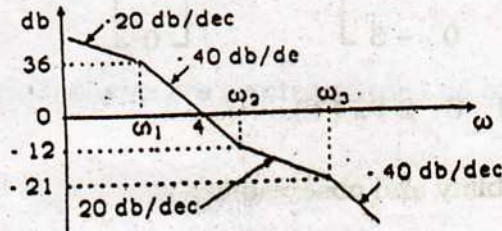

9. a) Explain sampling and hold. 3
- b) Find the pulse transfer function for the error sampled system shown in the following figure. 7

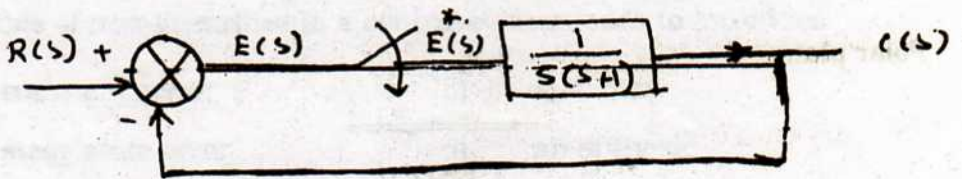

- c) Find the inverse and transform of the following system : 5

$$F(z) = \frac{4z^2 - 2z}{z^3 - 5z^2 + 8z - 4}$$



10. a) State the difference between describing function and transfer function. 5

b) A single input single output system is given by

$$\dot{x} = \begin{bmatrix} -1 & 0 & 0 \\ 0 & -2 & 0 \\ 0 & 0 & -3 \end{bmatrix} x(t) + \begin{bmatrix} 1 \\ 1 \\ 0 \end{bmatrix} u(t)$$

$$\text{and } y(t) = [1 \ 0 \ 2] x(t).$$

Test for controllability and observability. 5

c) Obtain the eigenvalues and eigenvectors for a system described by

$$X = \begin{bmatrix} 0 & 1 & 0 \\ 3 & 0 & 2 \\ -12 & -7 & -6 \end{bmatrix} \begin{bmatrix} x_1 \\ x_2 \\ x_3 \end{bmatrix} + \begin{bmatrix} 1 \\ 0 \\ 2 \end{bmatrix}, \quad Y = [1 \ 0 \ 0] X. \quad 5$$

11. Write short notes on any three of the following : 3 × 5

- PID controller
- Compensation techniques
- Phase plane technique of non-linear system analysis
- Dead zone and saturation type of non-linearity
- Polar plot.

END