

RS

S'05 : 4 FN : MC 403/PR 403 (96)

MECHANICS OF SOLIDS

Time : Three hours

Maximum marks : 100

*Answer FIVE questions, taking ANY TWO from Group A,
ANY TWO from Group B and ALL from Group C.*

*All parts of a question (a, b, etc) should be
answered at one place.*

Answer should be brief and to-the-point and be supplemented with neat sketches. Unnecessary long answers may result in loss of marks.

Any missing data or wrong data may be assumed suitably giving proper justification.

Figures on the right-hand side margin indicate full marks.

Group A

1. (a) Define creep. Draw a typical curve and explain three stages of the creep. 4

(Over)

- (b) Draw shear force and bending moment diagrams for the beam shown in figure below and label the salient values and the corresponding locations. 10

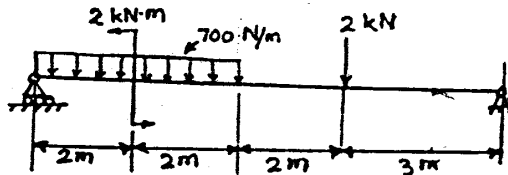

- (c) Explain the concepts of the following material properties and state their units: 6

- (i) Ductility
- (ii) Hardness
- (iii) Toughness.

2. (a) Draw a free body diagrams of the whole system, link AC and pulley D. 6

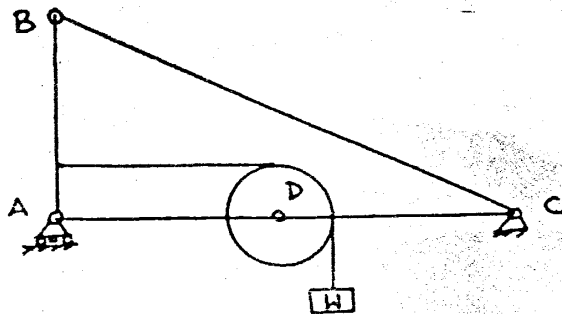

- (b) Find the reactions at the supports and the forces in all the links. 6

- (c) A specimen of 15 mm diameter and 200 mm long is subjected to tensile test and data at proportional and elastic limits were recorded as below:

Limit	Stress (MPa)	Increase in Length (mm)	Reduction in diameter (mm)
Proportional	340	00.90	?
Elastic	350	01.00	0.0225

- Find modulus of elasticity, Poisson's ratio and the reduction in diameter. 8

3. (a) Distinguish between the following: 6

- (i) Resilience and toughness
- (ii) Malleability and ductility
- (iii) Endurance life and endurance strength.

- (b) The maximum shear stress at a point in a stressed body is given as 1.58 MPa. The direct stress on the plane of maximum shear stress is 1.5 MPa and the principal plane makes an angle of 28° from x-axis. Find the state of stress at that point. 10

- (c) Distinguish between statically determinate and statically indeterminate beams. 4

4. (a) Draw dimensional sketch of specimens used for Izod and Charpy tests. Explain the two tests. 4

(b) The aluminium bar with a cross-section area of 160 mm^2 carries the axial loads at the positions shown in the Fig. Given that $E = 70 \text{ GPa}$, compute total change in length of the bar. 10

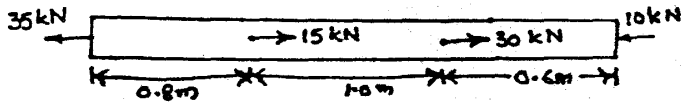

(c) Draw Mohr's circles for the following state of stresses: 6

(i) $\sigma_x = 0; \sigma_y = 0; \tau_{xy} \neq 0$

(ii) $\sigma_x \neq 0; \sigma_y = 0; \tau_{xy} = 0$

Group B

5. (a) A rigid bar of negligible weight is supported as shown in the Fig. If $W = 80 \text{ kN}$, compute the temperature change of the assembly that will cause a tensile stress

of 55 MPa in the steel rod. Use the following data: 14

	Area (mm^2)	α ($1/^\circ\text{C}$)	E (GPa)
Steel rod	320	11.7×10^{-6}	200
Bronze rod	1300	18.9×10^{-6}	83

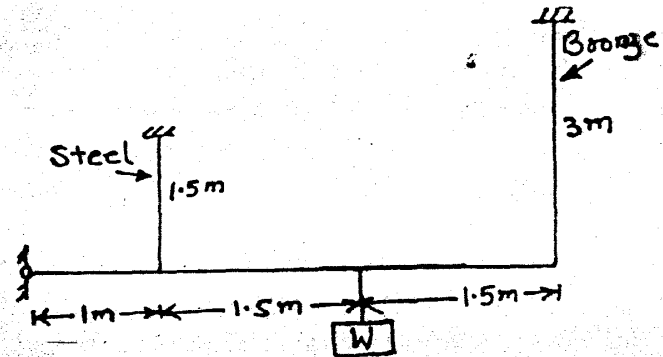

(b) A 1 m and 16 mm diameter bar is subjected to an axial pull P which induces a maximum stress of 150 MPa . Assuming that E for the bar material is 200 GPa , calculate the strain energy stored in the bar if load is reduced by 30%. 6

6. (a) A disc of uniform thickness is 915 mm in diameter and has a pinhole in the centre. If the density of material of the disc is 7800 kg/m^3 and Poisson's ratio is 0.3 . Find maximum hoop stress developed if the disc rotates at 3000 rpm . 8

(b) Prove that the maximum shear stress in a rectangular cross-section beam is 1.5 times of the average shear stress. Derive the formula for shear stress. 4

(c) A cylindrical pressure vessel is fabricated from steel plate and has a thickness of 20 mm. The inner diameter of the vessel is 450 mm, and its length is 2 m. Determine the maximum internal pressure that can be applied if the longitudinal stress is limited to 140 MPa and the circumferential stress is limited to 60 MPa. 8

7. (a) A 8 m shaft, 100 mm in diameter is made of a brittle material for which the allowable stress in tension or compression is 40 MPa. The shaft carries simultaneously the axial compressive load $P = 200$ kN and the torque T . Calculate the maximum allowable value of T using theory suitable for brittle material. 12

(b) State the assumptions made for developing torsion equation. 2

(c) Derive from fundamentals the torsion equation. 6

8. (a) A 10 m long solid steel shaft transmit 20 kW of power at 2 Hz. Determine the smallest safe diameter of the shaft if the shear stress is not to exceed 40 MPa and the angle of twist is limited to 6° in a length of 3 m. Use $G = 80$ GPa. 6

(b) A cantilever beam is composed of two segments with rectangular cross-section as shown in Fig. The width of each section is 5 mm but the depths are different as shown in the figure. Determine the maximum bending stress in the beam. What additional load P must be applied at B such that stresses at A and B become equal. 10

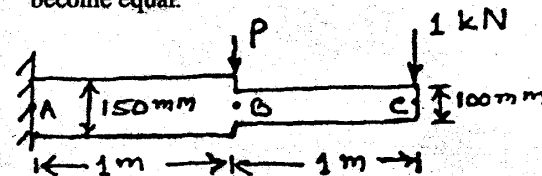

(c) A close coiled helical spring is required to have mean coil diameter to wire diameter ratio of 10. The spring will carry an axial load of 500 N and the maximum shearing stress is not to exceed 80 N/mm^2 . Calculate the diameter of wire. Take $G = 80$ GPa. 4

Group C

9. Choose the correct answer: 1 x 20

(i) If the Poisson's ratio is 0.25, the ratio of Young's modulus to modulus of rigidity is

- (a) 3.0
- (b) 2.5
- (c) 1.5
- (d) 3.5

(ii) A bar of diameter d and length l is made up of a material with modulus of elasticity E , and density ρ . If the bar is hanging from a ceiling, the total elongation under its self weight is

(a) $\frac{\rho l^2}{4E}$

(b) $\frac{2\rho l^2}{E}$

(c) $\frac{\rho l^2}{2E}$

(d) $\frac{3\rho l^2}{2E}$

(iii) The radius of Mohr's circle is equal to

(a) half of the sum of the two principal stresses

(b) half of the difference of two principal stresses

(c) sum of the two principal stresses

(d) difference of the two principal stresses

(iv) A beam of rectangular cross-section (width 120 mm and thickness 10 mm) is bent in a 10 m radius. If E is 200 GPa, then the magnitude of the pure moment is

(a) 0.2 kN m

(b) 2 kN m

(c) 2 kN mm

(d) 0.02 kN m

(v) How many equations of static equilibrium are there for a body in three-dimension space?

(a) two

(b) three

(c) six

(d) infinite

(vi) Which kind of the property will be of prime consideration if one chooses the material for immersion water heater?

(a) Mechanical property

(b) Thermal property

(c) Chemical property

(d) All are equally important

(vii) Which material has zero ductility?

(a) cast iron

(b) brass

(c) chalk

(d) all

(viii) Mild steel forms neck before it breaks. Neck formation starts

(a) before limit of proportionality

(xiv) For a beam shown in figure below, the maximum positive bending moment is equal to maximum negative bending moment, the value of l_1 is

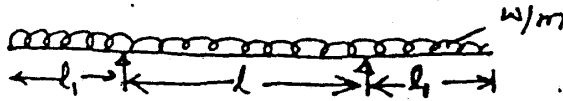

- (a) $\frac{l}{\sqrt{2}}$
- (b) $\frac{2l}{\sqrt{2}}$
- (c) $\frac{l}{4\sqrt{2}}$
- (d) $\frac{l}{2\sqrt{2}}$

(xv) If a circular shaft is subjected to a torque T and a bending moment M , the ratio of the maximum bending stress to the maximum shear stress is given by

- (a) $\frac{2M}{T}$
- (b) $\frac{M}{T}$

(c) $\frac{2T}{M}$

(d) Data incomplete

(xvi) In the figure shown below locate the point of maximum stress

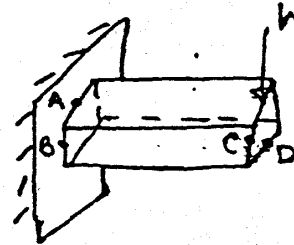

- (a) A
- (b) B
- (c) C
- (d) D

(xvii) A thin cylindrical shell of internal diameter D and thickness t is subjected to internal pressure p , the change in diameter is given by

- (a) $\frac{pD^2}{4tE} (2 - \nu)$
- (b) $\frac{pD^2}{4tE} (1 - 2\nu)$

$$(c) \frac{pD^2}{2tE} (1 - 2\nu)$$

$$(d) \frac{pD^2}{2tE} (2 - \nu)$$

(xviii) A rectangular beam is cut out of a cylinder of diameter D . The depth of the strongest beam will be

$$(a) \sqrt{\frac{1}{2}} D$$

$$(b) \sqrt{\frac{2}{3}} D$$

$$(c) \sqrt{\frac{5}{8}} D$$

$$(d) \sqrt{\frac{3}{4}} D$$

(xix) A simply supported beam of span l and flexural rigidity EI carries a unit point load at its centre. The strain energy in the beam due to bending is

$$(a) \frac{l^3}{48 EI}$$

$$(b) \frac{l^3}{192 EI}$$

$$(c) \frac{l^3}{96 EI}$$

$$(d) \frac{l^3}{16 EI}$$

(xx) For a helical closed coiled spring when subjected to an axial compressive load, the stresses produced in the spring wire will be

(a) compressive stress and direct shear stress

(b) compressive stress and torsion shear stress

(c) direct shear stress and torsion shear stress

(d) bending stress and direct shear stress

RS

W'05 : 4 FN : MC 403/PR 403 (1496)

MECHANICS OF SOLIDS

Time : Three hours

Maximum marks : 100

Answer FIVE questions, taking ANY TWO from Group A,
ANY TWO from Group B and ALL from Group C.

All parts of a question (a, b, etc) should be
answered at one place.

Answer should be brief and to-the-point and be supple-
mented with neat sketches. Unnecessary long answers
may result in loss of marks.

Any missing data or wrong data may be assumed suitably
giving proper justification.

Figures on the right-hand side margin indicate full marks.

Group A

1. (a) Two equal cylinders, each weighing 900 N are placed
in a box as shown in Fig. 1(a). Neglecting friction
between the cylinders and the box, estimate the
reactions at A, B and C. 10

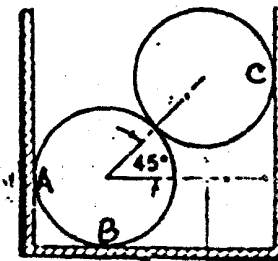

Fig 1(a)

(Turn Over)

(b) What do you understand by statically determinate and statically indeterminate structures? Explain. 10

2. (a) Define the shear force and bending moment at a section of a beam. Explain the utility of drawing shear force and bending moment diagrams for a beam. 8

(b) A simply supported beam as shown in Fig. 2(b) is 2.5 m long between the supports. It carries two concentrated loads of 70N and 40N at 1.5 m and 2.0 m respectively to the right of left support. Calculate the reactions R_1 and R_2 and draw the shear force and bending moment diagrams. 12

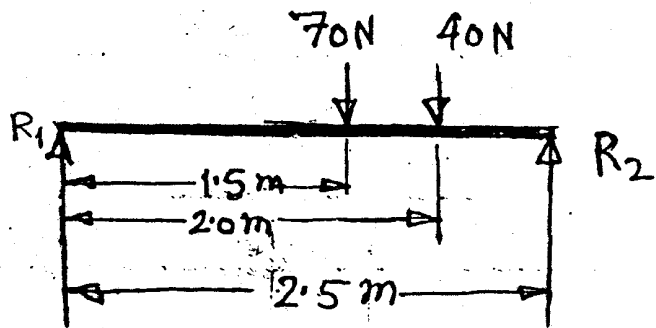

Fig. 2(b)

3. (a) Define the state of plane stress at a point. Enumerate the conditions for plane stress problems. Using these conditions write down the equations describing completely the relationship between stresses and strains. 2 + 2 + 4

(b) At a point in a stressed body the normal stresses are 83 N/mm^2 (tensile) on a vertical plane and 27.5 N/mm^2 (compressive) on a horizontal plane. Complementary shearing stresses of 41.4 N/mm^2 act on these planes. Determine the principal stresses and maximum shearing stress at this point. 12

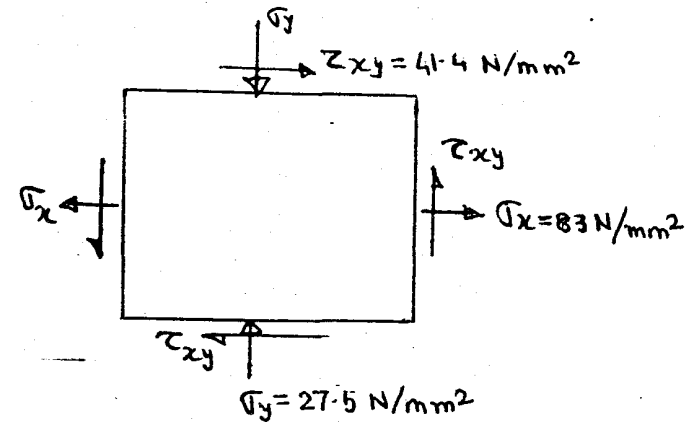

Fig. 3(b)

4. A steel specimen is tested in a standard tension test to evaluate several mechanical properties. The dimensions of the specimen and observations made during the test are given as per below:

Diameter of the specimen	= 12.5 mm
Gauge length	= 62.5 mm
Load at upper yield point	= 42.5 kN
Load at lower yield point	= 41.0 kN
Maximum load	= 72.5 kN
Fracture load	= 51.25 kN
Gauge length at fracture	= 80.5 mm
Diameter of fracture section	= 9.5 mm
Strain at a load of 20 kN	= 7.76×10^{-6} mm/mm

Determine: (i) the yield strength, (ii) the ultimate tensile strength, (iii) the % elongation, (iv) modulus of elasticity, (v) modulus of resilience, (vi) fracture stress, (vii) % reduction in area, (viii) modulus of toughness. 20

Group B

5. (a) What is Generalised Hooke's law? Write the governing equations. 6
- (b) What largest internal pressure can be applied to a cylindrical tank 1.8 m in diameter and 14 mm wall thickness if the ultimate tensile strength of steel used is 540 MPa and a factor of safety of 3 is desired? 14
6. (a) A steel cylinder with an inside diameter of 200 mm and an outside diameter of 300 mm is subjected to an internal pressure of 70 MPa. Determine the maximum tensile stress in the cylinder. 10
- (b) A turbine rotor is required to have a uniform stress of 150 MPa at a speed of 3200 rpm. The rotor is to be 30 mm thick at the centre. What will be its thickness at a radius of 40 mm? Assume $\rho = 7800 \text{ kg/m}^3$. 10
7. (a) A close-coiled helical spring is to have a stiffness of 900 N/m in compression, with a maximum load of 45 N and a maximum shearing stress of 120 N/mm^2 . The solid length of the spring is 45 mm. Find the wire diameter, mean coil radius and number of coils. $G = 40,000 \text{ N/mm}^2$. 10

(b) Compare the weights of equal lengths of hollow and solid shafts to transmit a given torque for the same maximum shear stress if the inside diameter is $\frac{2}{3}$ of the outside. 10

8. (a) State Castigliano's theorem? How it can be used to find the deflection under axial load? Explain. 6
- (b) List various theories of failures. What theories are followed by brittle materials? 4 + 2
- (c) A rectangular beam 6 cm \times 4 cm is 2 m long and is simply supported at the ends. It carries a load of 1 kN at mid-span. Determine the maximum bending stress induced in the beam. 8

Group C

9. Write down the short answers to the following: 2×10
- (i) What is cumulative fatigue damage?
- (ii) What is a creep curve? How are various stages in creep identified?
- (iii) What is hardness of a material, define?
- (iv) What is auto-fretage?
- (v) What is a point of contraflexure?
- (vi) What assumptions are made in simple theory of bending?
- (vii) How is the shearing stress distributed over the circular cross-section of a shaft, when subjected to a torque?

- (viii) Show the stress distribution over the cross-section of a close-coiled helical spring subjected to an axial load.
- (ix) How are the specimens supported in Charpy and Izod impact tests? Give supporting sketches.
- (x) Define modulus of resilience.

S'06 : 4 FN : MC 403/PR 403 (1496)**MECHANICS OF SOLIDS**

Time : Three hours

Maximum Marks : 100

*Answer FIVE questions, taking ANY TWO from Group A,
ANY TWO from Group B and ALL from Group C.*

*All parts of a question (a, b, etc.) should
be answered at one place.*

*Answer should be brief and to-the-point and be supplemented
with neat sketches. Unnecessary long answers may
result in loss of marks.*

*Any missing data or wrong data may be assumed suitably giving
proper justification.*

Figures on the right-hand side margin indicate full marks .

Group A

1. (a) A structural member 5 m long is made up of two materials. The first 1.7 m of its length is of brass and is 7.5 cm^2 in cross-section and the remainder of its length is of steel and is 6.0 cm^2 in cross-section. The bar is in tension under load P Newton and the total elongation of the bar is 0.1 cm. Determine:

(i) the magnitude of the load

(ii) the workdone in elongation of the bar.

Take : $E_s = 210 \text{ GPa}$

$E_b = 84 \text{ GPa}.$

10

(Turn Over)

- (b) A rod of length L tapers uniformly from a diameter D at one end to a diameter d at the other. Derive the expression for the extension caused by an axial load P . The material has Young's modulus of elasticity E . 10
2. (a) Distinguish between statically determinate and statically indeterminate beams. Show the difference by suitable examples with sketches. 4
- (b) A beam 10 m long is simply supported at its ends and carries concentrated loads of 40 kN and 50 kN at distances of 3 m from each end. Draw the shearing force and bending moment diagrams. Show the maximum values in the diagrams. 8
- (c) Obtain the expression for the maximum bending moment of a beam of length L and flexural rigidity EI , fixed horizontally at both ends, carrying a central concentrated load W . Draw the bending moment diagram of the beam. 8
3. (a) Explain strain compatibility relations for two-dimensional stress analysis problems. 4
- (b) Write the generalized Hooke's law to relate strain-stress for:
- (i) two-dimensional state of stress
- (ii) three-dimensional state of stress. 4

4FN:MC 403/PR 403 (1496) (2)

(Continued)

- (c) For two-dimensional stress system, show that:

$$\sigma_1 = \frac{E}{1-\nu^2} (\epsilon_1 + \nu \epsilon_2)$$

$$\text{and } \sigma_2 = \frac{E}{1-\nu^2} (\nu \epsilon_1 + \epsilon_2). \quad 4$$

- (d) The state of stress at a point in a loaded machine member is given by:

$$\sigma_x = 40 \text{ MPa}, \sigma_y = 55 \text{ MPa} \text{ and } \tau_{xy} = \pm 30 \text{ MPa}.$$

Determine the principal stresses and the maximum shearing stress at the point. Find out the planes on which they act. 8

4. (a) A Tensile Test has been carried out on a steel tube of external diameter 1.8 cm and bore 1.2 cm. An axial load of 2 kN produced a stretch, on a length of 5 cm, of 3.36×10^{-4} cm, and a lateral contraction of the outer diameter of 3.62×10^{-5} cm. Calculate:

(i) Young's modulus of elasticity

(ii) Poisson's ratio

(iii) Bulk modulus of the material. 10

- (b) Describe in detail any two of the Material Testings: 10

(i) Fatigue test to determine endurance strength

4FN:MC 403/PR 403 (1496) (3)

(Turn Over)

(ii) Izod Impact Test

(iii) Brinell Hardness Test.

Group B

5. (a) A steel tube 7.5 cm external diameter and 5 cm internal diameter houses within it a copper bar 5 cm in diameter of exactly the same length. The two pieces are rigidly fixed together by two pins 18 mm in diameter, one at each end passing through both bar and the tube. Calculate the stresses induced in the copper bar, steel tube and the pins if the temperature of the combination is raised by 50°C. Take:

$$E_s = 210 \text{ GPa}, \quad \alpha_s = 11.5 \times 10^{-6} \text{ per } ^\circ\text{C}$$

$$E_c = 105 \text{ GPa}, \quad \alpha_c = 17 \times 10^{-6} \text{ per } ^\circ\text{C}. \quad 10$$

- (b) Derive the expressions for hoop and longitudinal stresses induced in a thin cylindrical shell of internal diameter d and wall thickness t subjected to an internal fluid pressure p . 10
6. (a) In a hydraulic press, the cylinder has an internal diameter of 30 cm. The cylinder has to withstand an internal pressure of 10 MPa, without the material being stressed beyond 20 MPa. Determine the thickness of the metal and the stress on the outer surface of the thick cylinder. Sketch the diagram showing the variation of radial and hoop stresses across the wall thickness. 10

4FN:MC 403/PR 403 (1496) (4)

(Continued)

- (b) A steel disc of uniform thickness rotates at uniform angular speed ' ω ' without any angular acceleration. The density of the disc material is ' ρ '. Derive the expressions for principal stresses σ_1 and σ_2 induced in the disc. 10

7. (a) The internal diameter of a hollow shaft is two-thirds of its external diameter. Compare its resistance to torsion with that of a solid shaft of the same density and allowable strength of the material. The total weight of the two shafts are identical. 10

- (b) A close coiled helical spring of wire diameter d , mean coil radius R , number of turns of the spring coil n is subjected to an axial compressive load W . The spring material has a modulus of rigidity G . Derive the expression for the deflection of the spring. 10

8. (a) Explain the following two theories of failure: 8

(i) Maximum shearing stress theory

(ii) Maximum energy of distortion theory.

- (b) (i) Derive the following beam bending formula: 6

$$\frac{M}{I} = \frac{\sigma}{y} = \frac{E}{R} \quad 6$$

- (ii) A cantilever beam of rectangular cross-section (10 cm breadth \times 20 cm depth) is subjected to a concentrated load of 1000 N at the free end. The length of the beam is 3 m. Find the maximum bending stress induced in the beam. 6

4FN:MC 403/PR 403 (1496) (5)

(Turn Over)

Group C

9. Each of the following questions has four choices for the answer. Only one of them is *correct*. Write the *correct* answer code only in your answer book without repeating the language of the question: 1 × 20

(i) The change in length of a round steel rod subjected to an axial load P is

(a) $\frac{Pl}{4AE}$

(b) $\frac{Pl}{2AE}$

(c) $\frac{Pl}{AE}$

(d) $\frac{2Pl}{AE}$

(ii) A knuckle joint is to carry a load of 10 kN. The safe magnitude of the diameter of the connecting bolt with a safe allowable working stress in shear as 70 MPa is

(a) 1.5 cm

(b) 2.0 cm

(c) 2.5 cm

(d) 3.0 cm.

(iii) A load W is allowed to fall from a height h on to a collar fitted at the lower end of a bar of length L and cross-sectional area A , rigidly fixed at its upper end. The ratio of stress produced by suddenly applied load to that produced by the same load when gradually applied is

(a) 4

(b) 2

(c) 1

(d) $\frac{1}{2}$.

(iv) A beam fixed at two ends is subjected to an uniformly distributed load of w over its entire length l . The maximum bending moment induced in the beam is

(a) $\frac{wl^2}{24}$

(b) $\frac{wl^2}{12}$

(c) $\frac{wl^2}{8}$

(d) $\frac{wl^2}{4}$.

(v) At a point the state of stress is given by two principal stresses $\sigma_1 = 400$ MPa and $\sigma_2 = -400$ MPa. The third principal stress $\sigma_3 = 0$. The maximum shearing stress is

(a) 400 MPa

- (b) 200 MPa
- (c) 100 MPa
- (d) 0 MPa.
- (vi) An isotropic material has the following relationship between Young's modulus (E), Shearing modulus (G) and Poisson's ratio (ν)
- (a) $E = 2G(1 + 2\nu)$
- (b) $E = 2G(1 - 2\nu)$
- (c) $E = 2G(1 + \nu)$
- (d) $E = 2G(1 - \nu)$.
- (vii) Which one among the following is the most ductile material?
- (a) aluminium
- (b) brass
- (c) Cast iron
- (d) Steel.
- (viii) In Vicker's Hardness Test, the shape of the indenter is
- (a) Pyramid
- (b) Spherical ball

- (c) Solid cone
- (d) Solid cuboid.

(ix) The fatigue design formula $\frac{\sigma_m}{\sigma_u} + \frac{\sigma_a}{\sigma_e} = 1$ represents

- (a) Goodman's law
- (b) Soderberg's law
- (c) Gerber's law
- (d) Hooke's law.

(x) In a modern sophisticated Universal Testing machine, the purpose of LVDT is to measure

- (a) load
- (b) displacement
- (c) stress
- (d) strain.

(xi) In a thick cylinder subjected to internal pressure, the hoop stress through the thickness of the cylinder varies

- (a) exponentially
- (b) linearly
- (c) parabolically
- (d) cubically

(xii) A beam with rectangular cross-section is simply supported and subjected to a concentrated load at the middle. The variation of shear stress through the thickness of the beam is

- (a) constant
- (b) linear
- (c) quadratic
- (d) cubic.

(xiii) A coil spring of stiffness k is cut to exactly two halves to obtain two equal springs. Each of these springs has a stiffness

- (a) $\frac{k}{4}$
- (b) $\frac{k}{2}$
- (c) k
- (d) $2k$.

(xiv) Tresca yield criterion is related to

- (a) maximum principal stress theory
- (b) maximum principal strain theory
- (c) maximum energy of distortion theory
- (d) maximum shear stress theory.

(xv) A thin cylinder, diameter d and thickness of material t is subjected to an internal fluid pressure p . The maximum shear stress induced in the cylinder material is

- (a) $\frac{pd}{8t}$
- (b) $\frac{pd}{4t}$
- (c) $\frac{pd}{2t}$
- (d) $\frac{pd}{t}$

(xvi) A shaft made of steel has a shearing modulus (G). This is subjected to a torque T inducing a maximum shearing stress τ . The strain energy per unit volume in torsion is

- (a) $\frac{\tau^2}{8G}$
- (b) $\frac{\tau^2}{4G}$
- (c) $\frac{\tau^2}{2G}$
- (d) $\frac{\tau^2}{G}$.

(xvii) Torsional rigidity of a solid circular shaft of diameter d is proportional to

- (a) d^4
- (b) d^2
- (c) $\frac{1}{d^2}$
- (d) $\frac{1}{d^4}$

(xviii) Two equal length beams are simply supported at their ends. One carries a central load W and other carries the uniformly distributed load such that the total load is W . The ratio of maximum bending moment in the first case to that of the second is

- (a) 4
- (b) 2
- (c) 1
- (d) $\frac{1}{2}$

(xix) Toughness of a material is measured by

- (a) Creep Test
- (b) Hardness Test
- (c) Impact Test
- (d) Compression Test.

(xx) A beam of I-section is used to carry bending loads. The flanges of the I-section takes up

- (a) mostly bending stresses
- (b) mostly shearing stresses
- (c) both bending and shearing stresses equally
- (d) mostly shearing stresses and marginally bending stresses.

W'06 : 4 FN : MC 403 / PR 403 (1496)**MECHANICS OF SOLIDS***Time : Three hours**Maximum Marks : 100*

*Answer FIVE questions, taking ANY TWO from Group A ,
ANY TWO from Group B and ALL from Group C.*

*All parts of a question (a, b, etc.) should
be answered at one place.*

*Answer should be brief and to-the-point and be supplemented
with neat sketches. Unnecessary long answers may
result in loss of marks.*

*Any missing data or wrong data may be assumed suitably giving
proper justification.*

Figures on the right-hand side margin indicate full marks .

Group A

1. (a) The figure below shows a smooth cylinder of radius 0.2 m supporting a rod AB 0.6 m long weighing 100 N. The end A of the rod is hinged to the horizontal surface AD . The cylinder is also attached to the hinge by a string of length 0.2 m. Find the tension in the string. 10

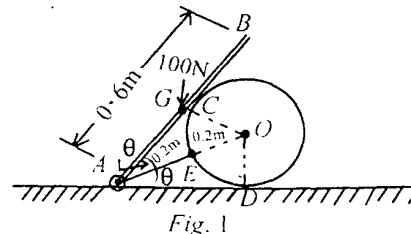

Fig. 1

- (b) If a tension test bar is found to taper uniformly from $(D - a)$ mm diameter to $(D + a)$ mm diameter, show that the error involved in using the mean diameter to calculate the Young's modulus is $(10 a / D)^2$ per cent. 10
2. (a) Draw the shearing force and bending moment diagrams for a simply supported beam carrying a uniformly distributed load. Show that the bending moment becomes maximum when the shearing force changes its sign. 8
- (b) A beam of 10 m length is simply supported at its ends. It carries a uniformly distributed load of 20 kN/m run over the length of left half of its span, together with concentrated loads of 20, 40 and 20 kN situated at 1.5, 2.5 and 5 m respectively from the right hand support. Draw the bending moment and shear force diagrams and find out the magnitude and position of the maximum bending moment taking place in the beam. 12
3. (a) Show that the major and minor principal stresses are given by

$$\sigma_{1,2} = \frac{1}{2} (\sigma_x + \sigma_y) \pm \frac{1}{2} \sqrt{(\sigma_x - \sigma_y)^2 + 4\tau_{xy}^2}$$

Show also that the planes of maximum shear stress are inclined at 45° with the principal planes. 10

- (b) The principal stresses at a point in a bar are 200 N/mm^2 (tensile) and 100 N/mm^2 (compressive). Determine the resultant stress in magnitude and direction on a plane inclined at 60° to the axis of the major principal stress and also the maximum shear stress in the material at the point. 10
4. (a) Define (i) Modulus of elasticity, (ii) Modulus of rigidity, (iii) Bulk modulus, and establish the relation among them. 10
- (b) The following data refer to a mild steel specimen tested in a laboratory:

Diameter of the specimen = 25 mm ;
 Length = 300 mm ;
 Extension under a load of 15 kN = 0.045 mm ;
 Load at yield point = 127.65 kN
 Maximum load = 208.6 kN ;
 Length of the specimen at failure = 375 mm ;
 Neck diameter = 17.75 mm .

Estimate (i) Young's modulus, (ii) Yield point, (iii) Ultimate stress, (iv) Percentage elongation, (v) Percentage reduction in area, (vi) Safe stress, using a factor of safety 2. 10

Group B

5. (a) Explain generalized Hooke's law. What do you mean by dilatation? 5
- (b) What is strain energy? Show that the strain energy per unit volume is $\sigma^2 / 2E$. 5

- (c) A steel tube 24 mm external diameter and 18 mm internal diameter encloses a copper rod 15 mm diameter to which it is rigidly joined at each end. If at a temperature of 10°C there is no longitudinal stress, calculate the stresses in the rod and the tube when the temperature is raised to 200°C. Given: $E_s = 2.1 \times 10^5 \text{ N/mm}^2$, $E_c = 1 \times 10^5 \text{ N/mm}^2$, $\alpha_s = 11 \times 10^{-6}/^\circ\text{C}$ and $\alpha_c = 18 \times 10^{-6}/^\circ\text{C}$. 10

6. (a) Give a derivation of the flexure formula for pure bending of a beam given below

$$\frac{\sigma}{y} = \frac{M}{I} = \frac{E}{R}$$

What is section modulus? 10

- (b) A cantilever beam 3m long is subjected to a uniformly distributed load of 30 kN/m. The allowable working stress in either tension or compression is 120 MN/m². The cross-section is to be rectangular, determine the dimensions if the height is twice as that of the width. 10
7. (a) Explain why hollow shafts are recommended for transmitting heavy torques. If the external radius of a hollow shaft is twice the internal radius, show that a hollow shaft is 1.443 times stronger than the solid shaft. 10
- (b) A solid circular shaft is to transmit 300 kW at 100 rpm. If the shear stress is not to exceed 80 N/mm² find the diameter of the shaft. What percentage saving in weight would be obtained if

this shaft is replaced by a hollow one whose internal diameter is equal to 0.6 of the external diameter, if the material, the length and the maximum shear stress remain the same? 10

8. (a) Explain the theories of elastic failure. What do you mean by brittle fracture and ductile fracture? 8
- (b) Show that the maximum shear stress for a shaft subjected to both bending and twisting is given by

$$\tau_{\max} = \frac{16}{\pi d^3} \sqrt{M^2 + T^2}$$

What do you mean by equivalent bending moment and equivalent torque? 10

- (c) What are compound shafts? 2

Group C

9. Write short answers to the following (any ten): 2 x 10
- (i) Draw the stress-strain diagrams of mild steel and cast iron.
- (ii) Define elastic limit and yield point.
- (iii) What is Poisson's ratio? What is the range of its value?
- (iv) Explain the modulus of resilience. What is proof resilience?
- (v) What do you mean by complementary shear stress?
- (vi) What is Mohr's circle? What is its significance?

- (vii) What are statically determinate beams ? When are they statically indeterminate ?
- (viii) Explain combined direct and bending stress. When is it tensile and when compressive ?
- (ix) What do you mean by a point of contraflexure ?
- (x) Explain Castigliano's theorem.
- (xi) What is the necessity of hardness testing ?
- (xii) What is the significance of Charpy and Izod tests ?
- (xiii) What is the meaning of the word 'universal' in the universal testing machine ?

S'07 : 4 FN : MC 403/PR 403 (1496)**MECHANICS OF SOLIDS***Time : Three hours**Maximum Marks : 100*

*Answer FIVE questions, taking ANY TWO from Group A ,
ANY TWO from Group B and ALL from Group C .*

*All parts of a question (a, b, etc.) should
be answered at one place.*

*Answer should be brief and to-the-point and be supplemented
with neat sketches. Unnecessary long answers may
result in loss of marks.*

*Any missing or wrong data may be assumed suitably giving
proper justification.*

Figures on the right-hand side margin indicate full marks .

Group A

1. (a) Explain various types of beams and supports. 6
- (b) Three cylinders A, B, C of weights 100N, 200N, 300N and radii 100 mm, 200 mm, 150 mm are placed in a rectangular ditch. Neglecting friction, determine reactions at various contact points. 14

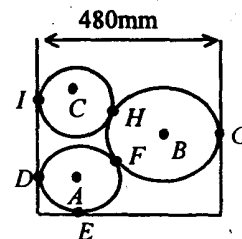

2. (a) Obtain relationship between shear force and bending moment. 6
- (b) Draw the SFD and BMD for the following beam shown in Fig. 1. 14

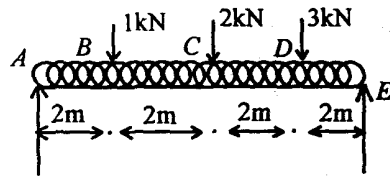

Fig.1

3. (a) Explain the construction of Mohr's circle when a member is suspected to biaxial perpendicular unequal and like principal stresses induced in plane stress condition. 10
- (b) A rectangular block of material in plane stress condition (MPa) is suspected to a tensile stress of 220 N/mm^2 on one plane and a tensile stress of 94 N/mm^2 on a plane at right angles, together with a shear stress of 126 N/mm^2 on the same planes. Find analytically the direction of principal planes, magnitude of principal stress, and the magnitude of greatest shear stress. 10
4. (a) The following data refer to a mild steel specimen tested in laboratory:-
- (i) Length of the specimen = 300 mm
- (ii) Diameter of the specimen = 25 mm

- (iii) Extension of the specimen = 0.045 mm
- (iv) Load at yield point = 127.65 kN
- (v) Maximum load = 208.60 kN
- (vi) Length after failure = 375 mm
- (vii) Neck diameter = 17.5 mm

Determine the Young's modulus, yield point stress, ultimate stress, d , percentage reduction in area, e , percentage increase in length of safe stress adopting a factor of safety 2. 12

- (b) Draw and explain the key stages in stress-strain graph for a ductile material. Compare the same with the graph of brittle material. 8

Group B

5. (a) What is thermal strain? Obtain an expression for it. 6
- (b) A steel bar is placed between two copper bars each having the same area and length as the steel bar is at 15°C . At this stage, they are rigidly connected together at both ends. When the temperature is raised to 315°C , the length of the bars increase by 1.5 mm. Determine the original length and final stress in bars. $E_S = 2.1 \times 10^5 \text{ N/mm}^2$ and $E_C = 1 \times 10^5 \text{ N/mm}^2$. $\alpha_S = 0.00012$ per degree centigrade and $\alpha_C = 0.000175$ per degree centigrade. 14

6. (a) A cylindrical thin drum, 800 mm in diameter and 3 m long, has a shell thickness of 10 mm. If the drum is subjected to an internal pressure of 2.5 N/mm^2 , determine the changes in length, diameter and volume. 10
- (b) The internal and external diameters of a thick hollow cylinder are 8 cm and 12 cm, respectively. It is subjected to an external pressure of 40 MPa and an internal pressure of 120 MPa. Calculate the circumferential stress at the external and internal surfaces and determine the radius and circumferential stresses at the mean radius. 10
7. (a) A close coiled helical spring is to have a stiffness of 1 N/mm of compression under a maximum load of 45 kN and a maximum shearing stress of 126 N/mm^2 . The solid length of the spring (when the coils are touching) is to be 45 mm. Find the diameter of the wire, the mean diameter of the coils, and number of coils required. Given shear modulus of spring is $C = 4.2 \times 10^4 \text{ N/mm}^2$. 8
- (b) A hollow shaft of diameter ratio $3/8$ is to transmit 375 kW at 100 rpm, the maximum torque being 20% greater than the mean. If the shear stress not to exceed 60 N/mm^2 and the twist in a length of 4 m is not to exceed 2° , then calculate the internal and external diameters which would satisfy both the above conditions. Shear modulus is $C = 8.5 \times 10^4 \text{ N/mm}^2$. 12

4FN:MC 403/PR 403(1496)

(4)

(Continued)

8. (a) Using Castigliano's theorem, obtain the deflection under a single concentrated load applied at simply-supported beam shown in Fig. 2. 12

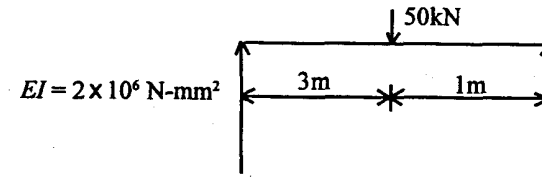

Fig.2

- (b) A cylindrical shell, made of mild steel plate and 120 cm its diameter, is to be subjected to an internal pressure of 1.5 MPa. If the material yields at 200 MPa, calculate the thickness of plate on the basis of (i) maximum principal stress theory, (ii) maximum shear stress theory, and (iii) maximum shear strain energy theory. Assume a factor of safety of 3 in each case. 8

Group C

9. Answer the following in brief: 2 x 10
- (i) What do you mean by hogging and sagging of beams?
- (ii) Name any four methods to measure hardness of a material.
- (iii) What do you mean by toughness of a material?
- (iv) What is proof resilience?

4FN:MC 403/PR 403(1496)

(5)

(Turn Over)

- (v) What are principal planes ?
- (vi) State Castigliano's theorem.
- (vii) Differentiate between open coiled and close-coiled helical springs.
- (viii) Give the relationship between longitudinal and hoop stress as applicable to a thin pressure vessel.
- (ix) Differentiate between statically determinate and statically indeterminate structures.
- (x) What are the assumptions made in developing the expressions for the stresses and deformations due to torsion ?

W'07 : 4 FN : MC 403 / PR 403 (1496)**MECHANICS OF SOLIDS***Time : Three hours**Maximum Marks : 100*

*Answer FIVE questions, taking ANY TWO from Group A ,
ANY TWO from Group B and ALL from Group C.*

*All parts of a question (a, b, etc.) should
be answered at one place.*

*Answer should be brief and to-the-point and be supplemented
with neat sketches. Unnecessary long answers may
result in loss of marks.*

*Any missing or wrong data may be assumed suitably giving
proper justification.*

Figures on the right-hand side margin indicate full marks.

Group A

1. (a) An electric light fixture, weighing 25 N, hangs from a point C by two strings AC and BC. The string AC is inclined at 60° to the horizontal and BC at 45° to the horizontal as shown in Fig. 1. Determine the forces in the strings AC and BC. 10

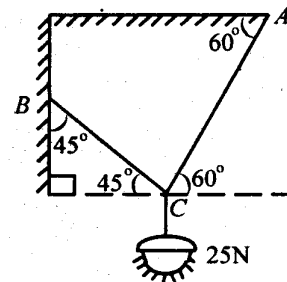

Fig. 1

(Turn Over)

- (b) A mild steel plate, 20 mm thick and 20 cm wide at the top, tapers uniformly to 10 mm thickness and 15 cm width over a length of 2 m. Find the elongation under a pull of 15 kN. Take $E = 210 \text{ GPa}$. 10
2. (a) How are the distributions of the loading, the shear force, and bending moment related to each other? Are there any pre-conditions for the relationship? 8
- (b) Calculate the reactions in the case of the beam shown in Fig. 2. Construct the shearing force and bending moment diagrams. Determine the location of the maximum bending moment, and mark it on each of the diagrams. 12

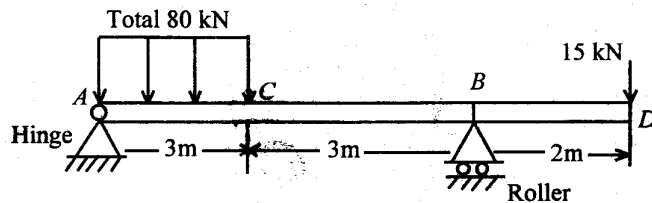

Fig. 2

3. (a) Derive an expression for the major and minor principal stresses on an oblique plane, when the body is subjected to direct stresses in two mutually perpendicular directions accompanied by shear stress. 10
- (b) At a point in a material, the stresses on two mutually perpendicular planes are 50 N/mm^2 (tensile) and 30 N/mm^2 (tensile). The shear stress across these planes is 12 N/mm^2 . Using Mohr circle, find the magnitude and direction of the resultant stress on a plane making an angle of 35° with the plane of the first stress. Also, find the normal and tangential stresses on these planes. 10

4. (a) Define the following properties of a material :
 (i) ductility, (ii) hardness, (iii) toughness, (iv) creep, (v) fatigue. 10

- (b) Following results were obtained in a tensile test on a mild steel specimen of original diameter 20 mm and gauge length 50 mm. At the limit of proportionality, the load was 100 kN and the extension was 0.05 mm. The specimen yielded at a load of 115 kN, and the maximum load withstood was 200 kN.

After rupture, the total length between gauge marks was found 6.67 cm and diameter of neck was 1.72 cm. Calculate Young's modulus, the stress at the limit of proportionality, the yield stress, the ultimate tensile stress, percentage elongation and contraction. 10

Group B

5. (a) What is impact loading? Derive the relation for the strain energy due to impact loading. 6
- (b) A rod, whose ends are fixed to rigid supports, is heated so that rise in temperature is $T^\circ\text{C}$. Prove that the thermal strain and thermal stresses set up in the rod are given by
- $$\text{Thermal strain} = \alpha \cdot T$$
- $$\text{Thermal stress} = \alpha \cdot T \cdot E.$$
- where α is the coefficient of linear expansion and E , the modulus of elasticity. 6

- (c) Two parallel walls, 8 m apart, are stayed together by a steel rod of 20 mm diameter passing through metal plates and nuts at each end. The nuts are screwed up to the plates while the bar is at a temperature of 400 K. Find the pull exerted by the bar after it has cooled to 300 K (i) if the ends do not yield, and (ii) if the total yielding is 5 mm. Take α for steel = 12×10^{-6} per K and $E = 2 \times 10^5 \text{ N/mm}^2$. 8
6. (a) Show that in thin cylinder shells subjected to internal fluid pressure, the circumferential stress is twice the longitudinal stress. 10
- (b) A copper cylinder, 90 cm long, 40 cm external diameter and wall thickness 6 mm, has its both ends closed by rigid blank flanges. It is initially full of oil at atmospheric pressure. Calculate the additional volume of oil which must be pumped into it in order to raise the oil pressure to 5 N/mm^2 above pressure. For copper, assume $E = 1.0 \times 10^5 \text{ N/mm}^2$ and Poisson's ratio = $1/3$. Take bulk modulus of oil as $2.6 \times 10^3 \text{ N/mm}^2$. 10
7. (a) Compare the torsional strength and the angle of twist of two shafts of the same length, weight and material. One of the shafts is solid and the other one is hollow with internal diameter one-third of the external diameter for the maximum shear stress. 10
- (b) Prove that the ratio of depth to width to the strongest beam that can be cut from a circular log of diameter 'd' is $\sqrt{2}$. Hence, calculate the depth and width of the strongest beam that can be cut of a cylindrical log of wood whose diameter is 200 mm. 10

8. (a) Prove that the deflection of a close-coiled helical spring due to axial load, W , is given by

$$\delta = 64 WR^{3n} / G. d^4$$

where R is the mean radius of spring coil; n , the number of coils; G , the modulus of rigidity; and D , the diameter of spring wire. 10

- (b) A disc of 50 cm diameter and uniform thickness is rotating at 2400 rpm. Determine the maximum stress induced in the disc. If a hole of 10 cm diameter is drilled at the centre of the disc, determine the maximum intensities of radial and hoop stresses induced. Take Poisson's ratio = 0.28 and density of disc material = 7800 kg/m^3 . 10

Group C

9. Write short answers to the following : 2 x 10
- (i) State Hooke's law.
- (ii) What do you mean by a bar of uniform strength?
- (iii) Explain briefly the terms 'shear stress' and 'complimentary shear stress' with proper illustrations.
- (iv) Explain Mohr's circle of stress.
- (v) Define resilience and modulus of resilience.
- (vi) What do you mean by the point of contraflexure?
- (vii) What do you mean by moment of resistance?
- (viii) Define the terms 'torsional rigidity' and 'polar moment of inertia'.

W'07: 4 FN: MC 403/PR 403(1496) (5)

- (ix) Differentiate between a thin cylinder and a thick cylinder.**
- (x) What are statically determinate beams? When are they statically indeterminate?**

AMIE(I) STUDY CIRCLE, SECOND FLOOR, SULTAN TOWER, ROORKEE - 247667 (UTTARANCHAL) EMAIL: pcourses@hotmail.com Ph: (01332) 266328, 9412903929, 9897394020

S'08 : 4 FN : MC 403/PR 403 (1496)**MECHANICS OF SOLIDS***Time : Three hours**Maximum Marks : 100*

*Answer FIVE questions, taking ANY TWO from Group A,
ANY TWO from Group B and ALL from Group C.*

*All parts of a question (a, b, etc.) should
be answered at one place.*

*Answer should be brief and to-the-point and be supplemented
with neat sketches. Unnecessary long answer may
result in loss of marks.*

*Any missing or wrong data may be assumed suitably giving
proper justification.*

Figures on the right-hand side margin indicate full marks.

Group A

1. (a) A rod of square section of side D at one end tapers to a square section at the other end. If its length is l , find the increase in length if it is subjected to an axial pull P .

8

(b) A horizontal bar AB , assumed to be rigid, is supported by two identical wires CE and DF (Fig. 1). If each wire has cross-sectional area A , determine the tensile stresses σ_1 and σ_2 in wires CE and DF , respectively.

12

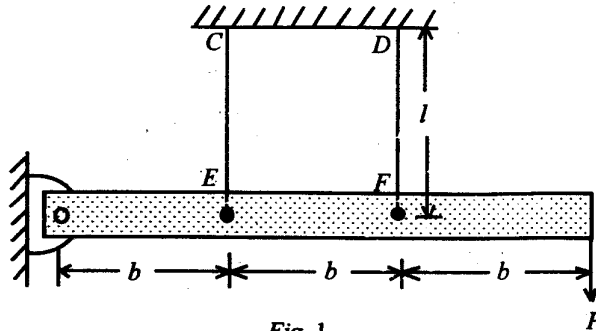

Fig. 1

2. (a) Distinguish between statically determinate and statically indeterminate beams.

4

(b) A cantilever beam of uniform flexural rigidity EI and length l is loaded by a concentrated load W at the mid-span, whereas the cantilever is propped at the free end. Level of the prop is the same as that of the fixed end. Determine the reaction at the prop. Also, draw the shear force and bending moment diagrams.

8

(c) A restrained beam AB carries a point load W at a distance a from support A and b from support B . If both the supports are at the same level, determine the end moments and sketch the SFD and BMD. The beam is fixed rigidly at both ends.

8

3. (a) Describe the graphical method of Mohr's circle construction for evaluation of principal stresses and the principal planes.

10

(b) A state of stress in a piece of elastic material is given by

$$\sigma_x = 800 \text{ MPa}$$

$$\sigma_y = -600 \text{ MPa}$$

$$\tau_{xy} = \pm 500 \text{ MPa}$$

Find the (i) principal stresses and the position of the planes on which they act; and (ii) position of the planes on which there is no normal stress. Solve the problem analytically using the transformation equations.

10

4. (a) Define 'fatigue strength' and 'fatigue life' of steel.

2

(b) Describe a standard fatigue test to determine the endurance limit of mild steel material.

8

(c) Describe the following impact tests clearly indicating the difference between them as regards the specimen and support fixtures for doing the experiment :

10

(i) IZOD test

(ii) CHARPY test.

Group B

5. (a) A steel bar, 4 cm in diameter and 5 m long, is heated through 60°C with ends clamped before heating. Estimate the thrust exerted by the steel bar on the clamps. Given : $E = 210 \text{ GPa}$ and coefficient of thermal expansion, $\alpha = 11 \times 10^{-6}$ per $^{\circ}\text{C}$. If the clamps have yielded by 0.05 cm, what would then be the thrust exerted? 8
- (b) Write and explain the generalized Hooke's law for an isotropic material. 4
- (c) A mild steel bar, 6 m long, is 5 cm in diameter for 3 m of its length and 2.5 cm in diameter for the remaining length. The bar is in tension and the stress on the smallest section is 112 MPa. Find the total elongation of the bar and the change in diameter at the smallest section. Given : $E = 200 \text{ GPa}$ and Poisson's ratio = 0.15. 8
6. (a) Enumerate the difference between the thin and thick cylinders under internal pressure. 4
- (b) Derive the expressions for hoop and longitudinal stresses for a thin cylinder of internal diameter d , material thickness t and subjected to internal fluid pressure p . 6
- (c) A thick cylinder of steel, having an internal diameter of 10 cm and an external diameter of 20 cm, is subjected to an internal pressure of 80 MPa and an external pressure of 10 MPa. Find the maximum normal and shearing stresses in the cylinder and calculate the change of external diameter. Given : $E = 200 \text{ GPa}$ and Poisson's ratio = 0.3. 10

7. (a) Two shafts of the same material and same lengths are subjected to the same torque. If the first shaft is of solid circular section and the second shaft is of hollow circular section, whose internal diameter is two-third of the outside diameter, and the maximum shear stress developed in each is the same, compare the weights of two shafts. 10
- (b) A close coiled helical spring, made out of 8 mm diameter wire, has 18 coils. Each coil is of 8 cm mean diameter. If the maximum allowable shear stress in the spring is 140 MPa, determine the maximum allowable load on the spring and elongation of the spring. Also, determine the stiffness of the spring. Take $G = 82 \text{ GPa}$. 10
- 8 (a) Describe the 'Tresca' yield criterion. Show the failure envelope in a two-dimensional stress space. 4
- (b) Distinguish between plane stress and plane strain problems of elasticity. Give one example each for both. 6
- (c) Enumerate the following for two-dimensional problems of elasticity : 10
- (i) Differential equations of equilibrium
- (ii) Boundary conditions
- (iii) Compatibility equations
- (iv) Airy's stress function and the bi-harmonic equation.

S'08 :4FN :MC 403/PR 403 (1496) (4)

(Continued)

S'08 :4FN :MC 403/PR 403 (1496) (5)

(Turn Over)

Group C

9. (A) Briefly describe the following : 2 x 5

- (i) Visco-elastic behaviour of materials
- (ii) Toughness of materials and their quantification
- (iii) Moment area theorem
- (iv) Castigliano's theorem
- (v) Stress-strain curve for mild steel showing salient points.

(B) Choose the *correct* answer and write the letter code accordingly for each of the following : 1 x 10

(i) Each of the two cables in the given figure is 6 m long. The allowable stress in the cable is 70 MPa. The cable material $E = 200$ GPa. The cross-sectional area of the cable is

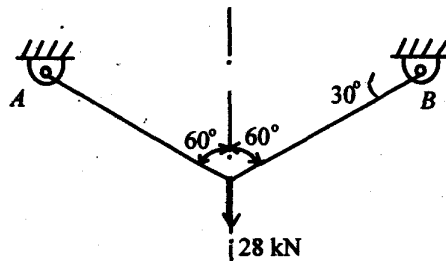

- (a) 4 cm²
- (b) 2 cm²
- (c) 8 cm²
- (d) 1 cm².

S'08 :4FN :MC 403/PR 403 (1496) (6)

(Continued)

(ii) A state of stress is shown as below :

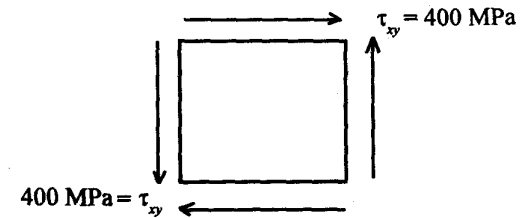

The principal stresses at the point are :

- (a) $\sigma_1 = - 400$ MPa, $\sigma_2 = - 400$ MPa
- (b) $\sigma_1 = \sigma_2 = 400$ MPa
- (c) $\sigma_1 = 800$ MPa, $\sigma_2 = - 800$ MPa
- (d) $\sigma_1 = 400$ MPa, $\sigma_2 = - 400$ MPa.

(iii) A simply-supported beam of span L and flexural rigidity EI is acted upon by a concentrated load W at the mid-span. The maximum deflection of the beam is

- (a) $WL^3/4 EI$
- (b) $WL^3/3 EI$
- (c) $WL^3/48 EI$
- (d) $WL^3/8 EI$

S'08 :4FN :MC 403/PR 403 (1496) (7)

(Turn Over)

(iv) A close coiled helical spring of mean coil radius R , coil wire diameter d is acted upon by a direct compression load W . The maximum shear stress induced in the spring wire is

(a) $\tau_{\max} = 8 WR/\pi d^3$

(b) $\tau_{\max} = 16 WR/\pi d^3$

(c) $\tau_{\max} = 4 WR/\pi d^3$

(d) $\tau_{\max} = 24 WR/\pi d^3$

(v) Identify the Goodman law for fatigue design :

(a) $(\sigma_m/\sigma_u) + (\sigma_a/\sigma_e) = 1$

(b) $(\sigma_m/\sigma_u)^2 + (\sigma_a/\sigma_e) = 1$

(c) $(\sigma_m/\sigma_y) + (\sigma_a/\sigma_e) = 1$

(d) $(\sigma_m/\sigma_y)^2 + (\sigma_a/\sigma_e)^2 = 1$

(vi) Tresca's yield criterion refers to

(a) maximum octahedral shear stress

(b) maximum shear stress

(c) maximum normal stress

(d) maximum strain energy.

(vii) There is a point load W at the mid-span of a fixed-fixed beam of length l . The moment at each of the fixed end is

(a) $Wl/2$

(b) $Wl/4$

(c) $Wl/16$

(d) $Wl/8$.

(viii) The hoop stress along the thickness of the wall of a thick cylinder subjected to internal pressure varies

(a) logarithmically

(b) linearly

(c) parabolically

(d) cubically.

(ix) The property of ductility of metals is related to

(a) elastic deformation

(b) plastic deformation

(c) hardness

(d) toughness.

(x) The stress at a point in an elastic body is a

(a) scalar

(b) vector

(c) tensor

(d) point function.

W'08 : 4 FN : MC 403/PR 403 (1496)**MECHANICS OF SOLIDS***Time : Three hours**Maximum Marks : 100*

*Answer FIVE questions, taking ANY TWO from Group A ,
ANY TWO from Group B and ALL from Group C.*

*All parts of a question (a, b, etc.) should
be answered at one place.*

*Answer should be brief and to-the-point and be supplemented
with neat sketches. Unnecessary long answers may
result in loss of marks.*

*Any missing or wrong data may be assumed suitably giving
proper justification.*

Figures on the right-hand side margin indicate full marks.

Group A

1. (a) A steel bar, 500 mm long and 75 mm diameter, is placed inside an aluminium tube with 80 mm inside diameter and 100 mm outside diameter. The tube is longer by 0.2 mm than the bar. An axial compressive load of 500 kN is applied through rigid cover plates fitted at both ends. Calculate the stresses in the bar and tube. Given: $E_s = 200 \text{ kN/mm}^2$ and $E_{al} = 75 \text{ kN/mm}^2$. 12

- (b) The ultimate shear stress of a MS plate is $40,000 \text{ N/cm}^2$. Determine the diameter of the hole that can be punched through it without exceeding a compressive stress of $80,000 \text{ N/cm}^2$ in the punch, the thickness of the plate being 12.5 mm . 8

2. (a) Construct the bending moment and shearing force diagrams for the beam shown in Fig. 1, and mark the values of important ordinates. 12

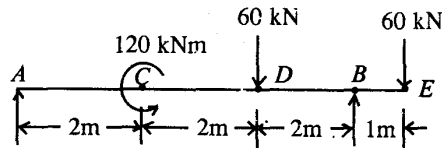

Fig.1

- (b) Define the following in case of a loaded beam : 2 x 4

- (i) Shear force diagram
- (ii) Bending moment diagram
- (iii) Axial force diagram
- (iv) Point of contraflexure.

3. (a) Explain the following terms : 2 + 3 + 3

- (i) Plane stress condition
- (ii) Major and minor principal planes
- (iii) Major and minor principal stresses.

- (b) The state of stress at a point in a stressed material is given by

$$\begin{aligned} \sigma_x &= 20 \text{ MPa} \\ \sigma_y &= 10 \text{ MPa} \\ \text{and } \tau_{xy} &= 25 \text{ MPa} \end{aligned}$$

Determine the direction and magnitude of the principal stresses in the material. Also, locate the planes of maximum shearing stress. 12

4. (a) A bar of 20 mm diameter is subjected to an axial tensile load of 120 kN , under which 200 mm gauge length of this bar elongates by an amount of $3.5 \times 10^{-4} \text{ m}$. Determine the modulus of elasticity of the bar material. If $\mu = 0.3$, determine its change in diameter. 10

- (b) Explain the mode of failure in torsion of (i) ductile material, and (ii) brittle material. 5

- (c) Explain the following : 5

- (i) Cumulative damage law
- (ii) Damage ratio.

Group B

5. (a) A steel cylinder, 90 cm long, 15 cm internal diameter, is made from plates of 5 mm thick. It is subjected to an internal pressure of 7 MPa . The increase in volume due to internal pressure is 16 cm^3 . Estimate the values of Poisson's ratio and modulus of rigidity. Assume $E = 210 \text{ GPa}$. 10

- (b) A disc of 50 cm diameter and uniform thickness is rotating at 2400 rpm. Determine the maximum stress induced in the disc. If a hole of 10 cm diameter is drilled at the centre of the disc, determine the maximum intensities of radial and hoop stresses induced. Assume $\mu = 0.28$ and density of disc = 7800 kg/m^3 . 10
6. (a) A helical spring, *B*, is placed inside the coils of a second helical spring, *A*, having the same number of coils and free axial length and of same material. The two springs are compressed by an axial load of 210 N which is shared between them. The mean coil diameters of *A* and *B* are 90 mm and 60 mm and the wire diameters are 12 mm and 7 mm, respectively. Calculate the load shared by individual springs and the maximum stress in each spring. 12
- (b) A beam of rectangular cross-section is to be cut from a circular log of diameter *D*. What should be the ratio of the depth of the beam to its width to resist maximum bending moment? 8
7. (a) Two copper plates, each 40 mm thick, are fastened together by a steel bolt, which has six threads per cm. Calculate the increase in stress in the bolt, if the nut is turned an additional 15° . Assume for steel $E = 210 \text{ GPa}$. What rise in temperature would produce the same increase in stress. Take $L_s = 11 \times 10^{-6} \text{ per } ^\circ\text{C}$ and $L_c = 17 \times 10^{-6} \text{ per } ^\circ\text{C}$. 10
- (b) What diameter of shaft will be required to transmit 80 kW at 60 rpm, if the maximum torque is 30% greater than the mean and the limit of torsional stress is to be 56 MPa? If the modulus of rigidity is 84 GPa, what is the maximum angle of twist in 3 m length? 10
8. (a) The stress components at a point are given by $\sigma_x = 20$, $\sigma_y = 10$, $\sigma_z = 15$, $\tau_{xy} = 5$, $\tau_{yz} = 10$, $\tau_{zx} = 20 \text{ MPa}$. Calculate the strain components. Assume $E = 200 \text{ GPa}$ and $\mu = 0.25$. 7
- (b) A thin cylinder, 80 mm mean diameter and 5 mm wall thickness, is closed at the ends and subjected to an internal pressure of 5 MPa. A torque of 1500 Nm is also applied to the tube. If the yield strength of the material of the tube is 240 MPa, calculate the factor of safety according to each of the following theories of failure: (i) Maximum principal stress theory, (ii) Maximum shear stress theory. Assume $\mu = 0.30$. 13

Group.C

9. (A) Write the *correct* answer for the following : 1×10
- (i) A straight bimetallic strip of copper and steel free at ends is heated. The strip will expand such that
- (a) both are under tension
- (b) both are under compression
- (c) copper will be under tension and steel under compression
- (d) copper will be under compression and steel under tension.

(ii) Under uniaxial loading, the maximum shear stress is equal to

- (a) uniaxial stress
- (b) half of uniaxial stress
- (c) twice of uniaxial stress
- (d) 1.5 times of uniaxial stress.

(iii) If the modulus of elasticity for a material is 200 GPa and Poisson's ratio is 0.25, then modulus of rigidity is

- (a) 250 GPa
- (b) 125 GPa
- (c) 80 GPa
- (d) 320 GPa.

(iv) The variation of bending moment due to uniformly distributed load is

- (a) uniform in nature
- (b) linear in nature
- (c) parabolic in nature
- (d) hyperbolic in nature.

(v) The diameter of shaft A is twice the diameter of shaft B and both are made of the same material. Assuming both the shafts to rotate at the same speed, the maximum power transmitted by B is

- (a) the same as that of A
- (b) half of A
- (c) one-eighth of A
- (d) one-fourth of A .

(vi) The ratio of the maximum hoop stress in a circular rotating disc having a pin hole at the centre to the maximum hoop stress in a solid disc is

- (a) 1
- (b) 2
- (c) 3
- (d) 1.5

(vii) The resilience of a closed coil helical spring under axial load is

- (a) τ^2/G
- (b) $\tau^2/2G$
- (c) $\tau^2/4G$
- (d) $\sigma^2/2E$.

(viii) Two springs having stiffnesses 2 N/m and 4 N/m are connected in parallel. The total stiffness of the system should be

(a) 6 N/m

(b) 2 N/m

(c) 8 N/m

(d) $(4/3)\text{ N/m}$.

(ix) By an isotropic material, we mean that the

(a) normal stress remains constant in all directions

(b) normal stress varies linearly in the material

(c) elastic constants are the same in all directions

(d) elastic constants vary linearly in material.

(x) In a simple bending of beams, the stresses across any cross-section of the beam

(a) varies linearly

(b) remains constant

(c) varies parabolically

(d) remains zero.

(B) Write short answers to the following : 2 x 5

(i) Differentiate between ductility and malleability.

(ii) Define brittleness and toughness.

(iii) Differentiate between single shear and double shear.

(iv) Define spring index and spring stiffness.

(v) Differentiate between primary, secondary and tertiary creep.

MECHANICS OF SOLIDS*Time : Three hours**Maximum Marks : 100*

*Answer FIVE questions, taking ANY TWO from Group A ,
ANY TWO from Group B and ALL from Group C.*

*All parts of a question (a, b, etc.) should
be answered at one place.*

*Answer should be brief and to-the-point and be supplemented
with neat sketches. Unnecessary long answers may
result in loss of marks.*

*Any missing or wrong data may be assumed suitably giving
proper justification.*

Figures on the right-hand side margin indicate full marks .

Group A

1. (a) Define the following: (i) Proportionality limit, (ii) Elastic limit, (iii) Yield point, (iv) Ultimate stress, (v) Rupture strength. 8

- (b) The following data refer to a mild steel specimen tested in a laboratory :

Diameter of the specimen = 25 mm

Extension under a load of 15 kN = 0.045 mm

Original length = 300 mm

Load at yield point = 127.65 kN

Maximum load = 208.6 kN

Length of the specimen at failure = 375 mm

Neck diameter = 17.75 mm

Estimate (i) Young's modulus, (ii) Yield point, (iii) Ultimate stress, (iv) Percentage elongation, (v) Percentage reduction in area, and (vi) Safe stress, using a factor of safety 2. 12

2. (a) Define (i) modulus of elasticity, (ii) modulus of rigidity, (iii) bulk modulus and establish the relation among them. 8

(b) If a tension test bar is found to taper uniformly from $(D - a)$ mm diameter to $(D + a)$ mm diameter, show that the error involved in using the mean diameter to calculate the Young's modulus is $(10a/D)^2$ per cent. 12

3. (a) The composite bar, consisting of steel and aluminium components as shown in Fig. 1, is connected to two grips at the ends at a temperature of 60°C . Find the stresses in two rods when the temperature falls to 20°C (i) if the ends do not yield, (ii) if the ends yield by 0.25 mm. Take $E_s = 2 \times 10^5$ and $E_a = 0.7 \times 10^5 \text{ N/mm}^2$, $\alpha_s = 1.17 \times 10^{-5}$ and $\alpha_a = 2.34 \times 10^{-5}$ per $^\circ\text{C}$. The areas of steel and aluminium bars are 250 mm^2 and 375 mm^2 , respectively. 12

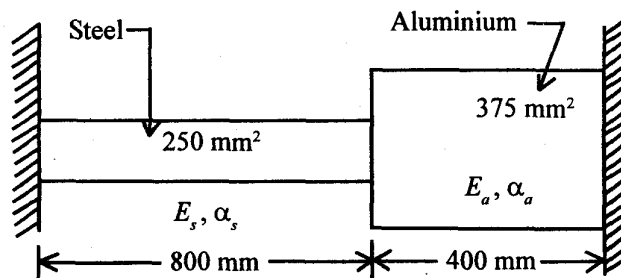

Fig. 1

- (b) A bar $30 \text{ mm} \times 30 \text{ mm} \times 250 \text{ mm}$ long is subjected to a pull of 90 kN in the direction of its length. The extension of the bar was found to be 0.125 mm, while the decrease in each lateral dimension is found to be 0.00375 mm. Find the Young's modulus, Poisson's ratio, modulus of rigidity and bulk modulus for the material of the bar. 8

4. (a) What do you mean by principal stresses and principal planes? Derive the expressions for normal stress and shear stress varying with inclination of the plane. 8

(b) The principal tensile stresses at a point across two perpendicular planes are 80 N/mm^2 and 40 N/mm^2 . Find the normal and shearing stresses, the resultant stress, and the obliquity on a plane at 20° with the major principal plane. Also, find the intensity of stress which acting alone can produce the same maximum strain. Take Poisson's ratio = 0.25. 12

Group B

5. (a) What are statically determinate beams? When are they statically indeterminate? What do you mean by bending stress and shear stress? 8

(b) A timber beam is freely supported on supports 6 m apart. It carries a uniformly distributed load of 12 kN/m and a concentrated load of 9 kN at 2.5 m from the left support. If the stress in timber is not

to exceed 8 N/mm^2 , design a suitable section making the depth twice the width (*Fig.2*). 12

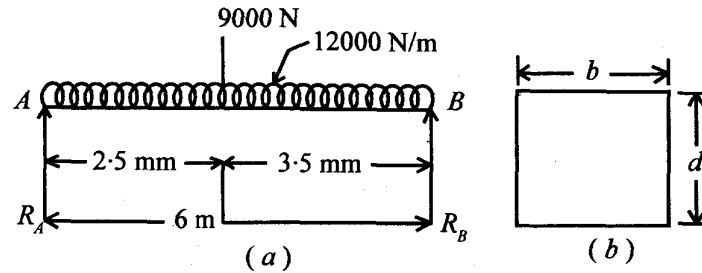

Fig. 2

6. (a) Give a derivation of the flexure formula for pure bending of a beam given below: 5

$$\frac{\sigma}{y} = \frac{M}{I} = \frac{E}{R}$$

(b) Explain combined direct and bending stress. When is the combined stress tensile and when is it compressive? 5

(c) A steel beam of hollow square cross-section of 60 mm outer side and 50 mm inner side is simply supported on a span of 4 m. Find the maximum concentrated load the beam can carry at the middle of the span, if the bending stress is not to exceed 120 N/mm^2 . 10

7. (a) Derive the torsion formula

$$\frac{T}{I} = \frac{G\theta}{L} = \frac{\tau}{r}$$

where T = torque applied, I = polar moment of inertia, G = modulus of rigidity, θ = angle of twist, L = length of shaft, τ = shearing stress and r = radius of shaft. 6

(b) What do you mean by torsional section modulus and torsional stiffness? 4

(c) A metal bar of 10 mm diameter, when subjected to a pull of 23.55 kN, gave an elongation of 0.30 mm on a gauge length of 200 mm. In a torsion test on the same material, a maximum shear stress of 40.71 N/mm^2 was measured on a bar of 50 mm diameter, the angle of twist measured over a length of 300 mm being $0^\circ 21'$. Determine the Poisson's ratio of the material. 10

8. (a) Explain strain energy in torsion. Show that the maximum strain energy per unit volume is $\tau^2/4G$. 5

(b) Two shafts of the same material and of the same lengths are subjected to the same torque. If the first shaft is of solid circular section and the second shaft is of hollow section whose internal diameter is two-third of the outside diameter, compare the weights of two shafts. 12

(c) Why are hollow shafts recommended for transmitting heavy torques? 3

Group C

9. (A) Write short notes on any *five* of the following: 2×5

- (i) Stress-strain diagram of mild steel
- (ii) Modulus of resilience
- (iii) Stress due to an impact load
- (iv) Mohr's circle
- (v) Middle quarter rule for a circular column
- (vi) Compound shaft
- (vii) Fatigue and creep
- (viii) Thermal strain.

(B) Choose the *correct* answer for the following: 1×10

- (i) The property of a material by virtue of which a body returns to its original shape after removal of the load is called
 - (a) plasticity
 - (b) elasticity
 - (c) ductility
 - (d) resilience.
- (ii) The impact strength of a material is an index of its
 - (a) toughness
 - (b) hardness
 - (c) tensile strength
 - (d) fatigue strength.

(iii) The intensity of stress which causes unit strain is called

- (a) bulk modulus
- (b) modulus of rigidity
- (c) modulus of elasticity
- (d) principal stress.

(iv) The bending moment in a beam becomes maximum when the shearing force

- (a) becomes minimum
- (b) becomes zero
- (c) becomes negative
- (d) changes its sign.

(v) A beam of length L carrying a uniformly distributed load of w kg per unit length is supported freely at the ends. The bending moment at mid-span will be

- (a) $wL/4$
- (b) $wL^2/2$
- (c) $wL^2/4$
- (d) $wL^2/8$.

(vi) The ratio of shear modulus to the modulus of elasticity, if Poisson's ratio is 0.25, will be

- (a) 0.4
- (b) 0.25
- (c) 4
- (d) 0.5.

(vii) Compare the strengths of a solid shaft and a hollow shaft having outside diameter twice the inside diameter in torsion. The ratio of strength of hollow to solid shaft in torsion will be

- (a) 0.5
- (b) 1.443
- (c) 1.352
- (d) 1.215.

(viii) The section modulus of a circular section about an axis through its centre of gravity is

- (a) $\pi d^3/16$
- (b) $\pi d^3/32$
- (c) $\pi d^2/32$
- (d) $\pi d^3/64$.

(ix) Mohr's circle can be used to determine the following on inclined surface:

- (a) Principal stresses
- (b) Normal and tangential stresses
- (c) Maximum shear stress
- (d) All of the above.

(x) Bulk modulus, K , in terms of modulus of elasticity, E , and Poisson's ratio, ν , is given by

- (a) $E/[3(1-2\nu)]$
- (b) $E(1-2\nu)$
- (c) $3E(1-2\nu)$
- (d) $E(1-2\nu)/3$.

W'09 : 4 FN : MC 403/PR 403 (1496)**MECHANICS OF SOLIDS***Time : Three hours**Maximum Marks : 100*

*Answer FIVE questions, taking ANY TWO from Group A ,
ANY TWO from Group B and ALL from Group C.*

*All parts of a question (a, b, etc.) should
be answered at one place.*

*Answer should be brief and to-the-point and be supplemented
with neat sketches. Unnecessary long answers may
result in loss of marks.*

*Any missing or wrong data may be assumed suitably giving
proper justification.*

Figures on the right-hand side margin indicate full marks .

Group A

1. (a) Draw a typical stress-strain diagram for a ductile material and explain the salient points of the curve. 8
- (b) A load of 300 kN is applied on a short concrete column 250 mm × 250 mm. The column is reinforced by steel bars of total area 5600 mm². If modulus of elasticity of steel is 15 times that of concrete , find the stresses in concrete and steel. If the stress in concrete should not exceed 4 N/mm² , find the area of steel required so that the column may support a load of 600 kN. 12

2. (a) When an element is in a state of simple shear, prove that the planes of maximum normal stresses are perpendicular to each other and these planes are inclined at an angle of 45° to the planes of pure shear. 8

(b) Calculate the modulus of rigidity and bulk modulus of a cylindrical bar of diameter 30 mm and of length 1.5 m, if the longitudinal strain in a bar during a tensile test is four times the lateral strain. Find the change in volume, when the bar is subjected to a hydrostatic pressure of 100 N/mm^2 . Take $E = 1 \times 10^5 \text{ N/mm}^2$. 12

3. (a) A straight bar of uniform cross-section is loaded in axial tension. Determine the normal and shearing stress intensities on a plane inclined at angle θ° to the axis of the bar. Also, determine the magnitude and direction of the maximum shearing stress in the bar. 10

(b) The principal stresses at a point in a body are 30 mN/m^2 and 50 mN/m^2 , both tensile. Determine, by calculations or by Mohr's circle, the following on a plane inclined at 40° to the plane on which the major principal stress acts:

- (i) Normal and tangential components of stress
- (ii) Magnitude of resultant stress
- (iii) Angle of obliquity. 10

4. (a) Define (i) hardness, (ii) toughness, (iii) fatigue, (iv) creep, and (v) impact strength. 2×5

W'09: 4 FN: MC403/PR403 (1496) (2)

(Continued)

(b) An aluminium solid cylinder of 7.5 cm diameter fits loosely inside a steel tube having 10 cm external diameter and 8 cm internal diameter. The steel tube is 0.02 cm longer than aluminium cylinder and is 250 cm long before the load is applied. Calculate the safe load which can be placed on a rigid flat plate on the top of the steel tube. Safe stress for steel is 95 MPa and for aluminium 65 mPa, $E_s = 210 \text{ GPa}$, and $E_a = 70 \text{ GPa}$. 10

Group B

5. (a) Prove that the maximum stress induced in a body due to suddenly applied load is twice the stress induced when the same load is applied gradually. 8

(b) A bar of uniform cross-section A and length L hangs vertically, subjected to its own weight. Prove that the strain energy stored within the bar is given by

$$U = (A \times \rho^2 \times L^3) / 6E$$

where E = modulus of elasticity and ρ = weight per unit volume of the bar. 12

6. (a) Derive an expression for the shear stress produced in a circular shaft which is subjected to torsion. What are the assumptions made in the derivation? 8

(b) Prove that

$$\frac{P_S}{P_H} = \frac{T_S}{T_H} = \frac{1}{(1 - k^4)}$$

where P_S = power transmitted by solid shaft;
 P_H = power transmitted by hollow shaft; T_S = torque
transmitted by solid shaft; T_H = torque transmitted by
hollow shaft; and $K = (d/D)$ = (inner dia of
shaft)/(outer dia of shaft). 12

7. (a) Show that in thin cylindrical shells, subjected to internal fluid pressure, the circumferential stress is twice the longitudinal stress. 8
- (b) A cylindrical shell 90 cm long, 15 cm internal diameter, having thickness of metal 8 mm is fitted with fluid at atmospheric pressure. If an additional 20 cm^3 of fluid is pumped into the cylinder, find the (i) pressure exerted by the fluid on the cylinder, and (ii) hoop stress induced. Take $E = 200 \text{ GPa}$, $\nu = 0.3$. 12
8. (a) What is section modulus? Find an expression for section modulus for a rectangular, circular and hollow circular sections. 6
- (b) A hollow shaft, having an inside diameter 60% of its outer diameter, is to replace a solid shaft transmitting the same power at the same speed. Calculate the percentage saving in material, if the material to be used is also the same. 6
- (c) A closely coiled helical spring of round steel wire, 10 mm in diameter having 10 complete turns with a mean diameter of 12 cm, is subjected to an axial load of 200 N. Determine the (i) deflection of the spring, (ii) maximum shear stress in the wire, and (iii) stiffness of the spring. Take $G = 8 \times 10^4 \text{ N/mm}^2$. 8

Group C

9. Answer the following in brief: 2 × 10
- (i) Free body diagram.
- (ii) Statically determinate and indeterminate beams.
- (iii) Force and stress.
- (iv) Thin and thick cylinders.
- (v) Principal planes and principal stresses.
- (vi) Proof resilience.
- (vii) Generalized Hooke's law.
- (viii) Yield criteria.
- (ix) Neutral axis centroid.
- (x) Stresses in rotating disks.

S'10 : 4 FN : MC 403/PR 403 (1496)**MECHANICS OF SOLIDS**

Time : Three hours

Maximum Marks : 100

*Answer FIVE questions, taking ANY TWO from Group A ,
ANY TWO from Group B and ALL from Group C .*

*All parts of a question (a, b, etc.) should
be answered at one place.*

*Answer should be brief and to-the-point and be supplemented
with neat sketches. Unnecessary long answers may
result in loss of marks.*

*Any missing or wrong data may be assumed suitably giving
proper justification.*

Figures on the right-hand side margin indicate full marks .

Group A

- (a) A bar of length l and cross-section $a \times b$ is subjected to an axial tensile force P . Cut the beam by a plane which is inclined to axis at an angle θ . Show the free body diagram of the bar. What are the stresses on the cut cross-section ? 10
- (b) Show the stress-strain diagram for a mild steel specimen under tension. Remember mild steel shows marked yield behaviour. Show on the diagram elastic limit, upper yield point, lower yield point and ultimate strength. Give reason why ultimate tensile strength is greater than yield strength after defining the yield strength. 10

2. (a) Figure 1 shows three short columns, each with cross-sectional area of 100 mm^2 , supporting a weightless rigid beam. Where should a force P be applied with respect to A so that initially horizontal beam remains horizontal after load application? 12

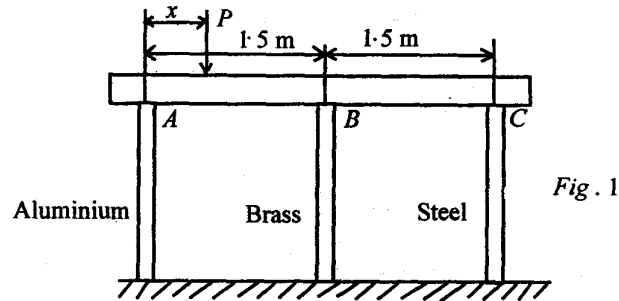

Modulus of elasticity :

Aluminium, $E = 69 \times 10^3 \text{ N/mm}^2$

Brass, $E = 103.5 \text{ N/mm}^2$

Steel, $E = 206 \times 10^3 \text{ N/mm}^2$

- (b) The state of stress at a point in a body of material is shown in Fig. 2. Find principal stresses and show on diagram with reference axis of original shearing stress. Identify a loaded member which will have the state of stress as shown in Fig. 2 and what will be the fracture surface if load is increased to cause the fracture. 8

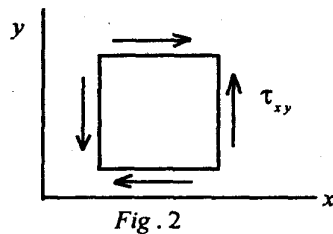

3. (a) Figure 3 are shows a loaded beam. Write equations for bending moments and shearing force for sections between A and B , B and C , and C and D . Draw shearing force and bending moment diagram for beam. In which curve the beam deforms between B and C , Identify a practical situation where this type of loading is obtained. 12

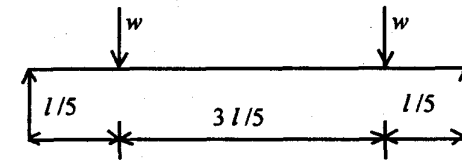

Fig. 3

- (b) Specifications for timber block of Fig. 4 require that the stresses do not exceed the following : shearing parallel to grains, 9 N/mm^2 and compression perpendicular to grain 17.25 N/mm^2 . Determine the maximum value of axial load P that can be applied without exceeding the limits. 8

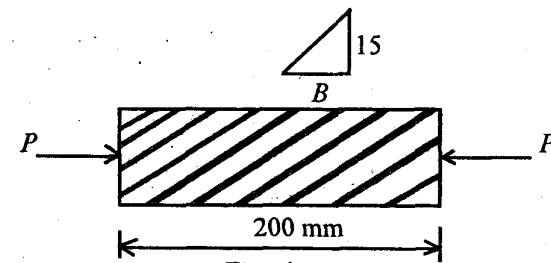
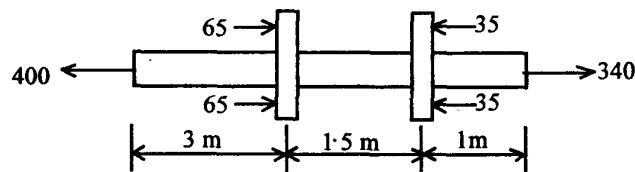

Fig : 4

Depth \times width of section = $12.5 \times 75 \text{ mm}^2$

4. (a) State Hooke's law and define constants of elasticity as E , G , γ and K . How many of these are independent for an isotropic elastic material? 4
- (b) State generalized Hooke's law for six stress and six strain components. What is an orthotropic elastic material and how many of elastic constants are independent for this material? 6
- (c) Two rigid yokes B and C of Fig.5 are securely fastened to 50 mm square steel bar AD . Determine total elongation of 5.5 m length. $E = 2 \times 10^5 \text{ N/mm}^2$. 10



(All forces in kN)

Fig. 5

Group B

5. (a) Show that, for a cylindrical vessel with a shell thickness of one-tenth of inner radius and subjected to only internal pressure, the error involved in computing the hoop stress by thin cylinder formula is approximately 5%. 10
- (b) A simply-supported beam over a span of 6 m carrier is concentrated on load P at a distance of 1.5 m from

left-hand support. The beam has 100 mm \times 300 mm rectangular cross-section. Determine the maximum permissible value of P , if the bending stress is not to exceed 8.25 N/mm^2 when (i) 100 mm side is horizontal, and (ii) 300 mm side is horizontal. 10

6. (a) Show that the shearing stress on inside of the coil of a close coiled helical spring is larger than that on the outside. Calculate the factor by which stress on the inside is higher. Calculate the total stress on the inside. 10
- (b) A turbine rotor disc is 600 mm in diameter at the blade ring and is keyed to shaft 50 mm in diameter. If the minimum thickness is not less than 12.5 mm, what should be its thickness at the shaft for disc to have uniform stress of 210 MPa at 10,000 rpm. The density of disc material is 7800 kg/m^3 . 10
7. (a) A composite shaft is made of three segments AB , BC and CD . All three are joined with common axis. The material, diameter, length and modulus of rigidity of three segments are given below :

- AB - Material 1, $d_1 = 50 \text{ mm}$, $L_1 = 1200 \text{ mm}$,
 $G_1 = 59 \times 10^3 \text{ N/mm}^2$
 BC - Material 2, $d_2 = 45 \text{ mm}$, $L_2 = 800 \text{ mm}$,
 $G_2 = 71 \times 10^3 \text{ N/mm}^2$
 CD - Material 3, $d_3 = 35 \text{ mm}$, $L_3 = 400 \text{ mm}$,
 $G_3 = 82 \times 10^3 \text{ N/mm}^2$.

What torque this shaft can carry at section D , if angle of twist between fixed section A and D , $\theta_{DA} = 6^\circ$. 10

- (b) In Fig. 6, the bar on left is copper and that on right is steel. The diameter of each bar is 60 mm. The gap between the bars is 0.25 mm. Determine the (i) total force on each bar, if temperature is raised by 40°C, and (ii) deformation in each bar. The distance between the supports remains unchanged.

$$\alpha_{\text{steel}} = 11.5 \times 10^{-6} \text{ per deg C}$$

$$\alpha_{\text{copper}} = 16.5 \times 10^{-6} \text{ per deg C}$$

$$E_{\text{steel}} = 2.1 \times 10^5 \text{ N/mm}^2,$$

$$E_{\text{copper}} = 113 \times 10^5 \text{ N/mm}^2.$$

10

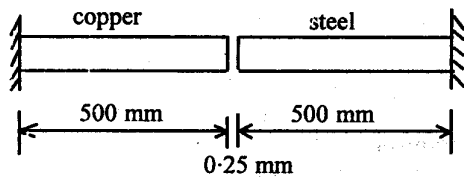

Fig. 6

8. (a) Choose a small plane element of size dx and dy in $x - y$ plane. Calling normal stresses as σ_x and σ_y and shearing stress τ_{xy} , derive the equation of equilibrium. Assume body forces in x - and y -direction as X and Y .

5

- (b) A torque T twists a shaft of length L , the angle of twist being θ . Develop an expression for strain energy stored in the shaft in terms of T , L , G and J .

5

- (c) A spring is coiled closely to have 10 coils of 50 mm mean diameter from steel rod of 5 mm diameter. Calculate the deflection under an axial load of 50N. Compare this deflection with the deflection of the rod from which the spring is made if the same load is applied along the axis of the rod. Also, calculate stresses in spring and the rod.

$$E = 2.1 \times 10^5 \text{ N/mm}^2, G = 0.84 \times 10^5 \text{ N/mm}^2. \quad 10$$

Group C

9. Answer the following in brief : 2 x 10

- (i) What is the information obtained from an impact test ?
 (ii) How do you find ductility of a material from tension test ?
 (iii) Which of (a) and (b) is statically determinate and indeterminate ?

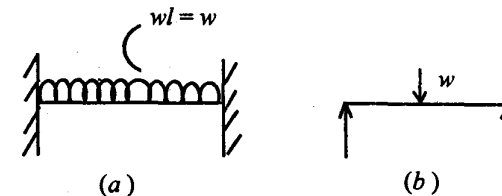

- (iv) Draw Mohr circle for state of pure shear.
 (v) If u , v and w are displacement components of a point in elastic body along x -, y -, and z -axes, respectively, write expression for strains.

- (vi) Show stress distribution in solid rotating disc.**
- (vii) What do you understand by yield criteria ?**
- (viii) Draw a typical creep curve for metal. Mark creep stages.**
- (ix) Define neutral plane of a beam and neutral axis of cross-section of a beam.**
- (x) If the energy of a beam is U , when beam is loaded by a concentrated load, what is the deflection of beam under the load.**

W'10:4FN:MC 403/PR 403 (1496)**MECHANICS OF SOLIDS***Time : Three hours**Maximum Marks : 100*

Answer FIVE questions, taking ANY TWO from Group A, ANY TWO from Group B and ALL from Group C.

All parts of a question (a, b, etc.) should be answered at one place.

Answer should be brief and to-the-point and be supplemented with neat sketches. Unnecessary long answers may result in loss of marks.

Any missing or wrong data may be assumed suitably giving proper justification.

Figures on the right-hand side margin indicate full marks.

Group A

1. (a) Draw the stress-strain diagrams of mild steel and cast iron, and explain the difference. 4
- (b) Define the following: (i) Proportionality limit, (ii) Elastic limit, (iii) Yield point, and (iv) Ultimate stress. 6
- (c) The following data refer to a tensile test conducted on a mild steel bar:
 - (i) Diameter of the steel bar = 30 mm
 - (ii) Length = 250 mm
 - (iii) Extension at a load of 100 kN = 0.14 mm

- (iv) Load at elastic limit = 230 kN
- (v) Maximum load = 350 kN
- (vi) Total extension = 54 mm
- (vii) Diameter of the rod at failure = 22.5 mm.

Calculate the Young's modulus, the stress at elastic limit, the percentage elongation, and the percentage decrease in area.

10

2. (a) Define the modulus of elasticity (E), the modulus of rigidity (G), the bulk modulus (K), and establish the relation among them as given below :

10

$$E = 9KG / (3K + G)$$

- (b) There is a 2% error in the determination of G . If E is assumed to be correctly determined, what will be the error in the calculation of Poisson's ratio when its correct value is 0.2 ?
- (c) What do you mean by complementary shear stress ?
3. (a) Describe the graphical method of Mohr's circle construction for evaluation of principal stresses and principal planes.
- (b) The principal stresses at a point in a bar are 200 N/mm^2 (tensile) and 100 N/mm^2 (compressive). Determine the resultant stress in magnitude and direction on a plane inclined at 60° to the axis of the major principal stress and also the maximum shear stress in the material at the point.
4. (a) What do you understand by bending stress and

8

2

10

10

- (b) Distinguish between statically determinate and statically indeterminate beams.

4

- (c) Write the shear and moment equations for the beam loaded as shown in Fig. 1, and draw the shear force and bending moment diagrams. Find the section where maximum bending moment occurs.

12

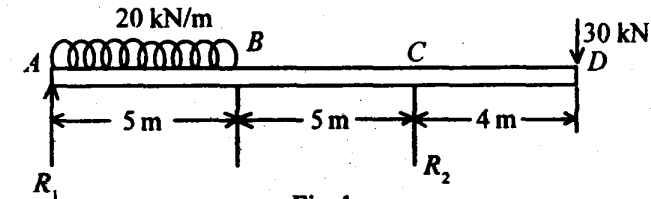

Fig. 1

Group B

5. (a) Give a derivation of the flexure formula for pure bending of a beam given below :

5

$$\frac{\sigma}{y} = \frac{M}{I} = \frac{E}{R}$$

- (b) Explain combined direct and bending stress. When is the combined stress tensile and when is it compressive ?

5

- (c) A steel beam of a hollow square section of 60 mm outer side and 50 mm inner side is simply supported on a span of 4 m. Find the maximum concentrated load the beam can carry at the middle of the span, if the bending stress is not to exceed 120 N/mm^2 .

10

6. (a) Derive the torsion formula

$$\frac{T}{J} = \frac{G\theta}{L} = \frac{\tau}{r}$$

where J is the polar moment of inertia. 5

- (b) A solid circular shaft is to transmit 300 kW at 100 rpm. If the shear stress is not to exceed 80 N/mm², find the diameter of the shaft. What percentage saving in weight would be obtained, if this shaft is replaced by a hollow one whose internal diameter is equal to 0.6 of the external diameter, if the material, the length, and the maximum shear stress remain the same. 12

- (c) What do you mean by torsional stiffness? 3

7. (a) What is thermal stress? Show that the thermal stress in a bar of tapering section is given by 8

$$\sigma_t = E\alpha\Delta t (d_1 / d_2)$$

- (b) A steel rod, 2.5 m long, is secured between two walls. If the load on the rod is zero at 20 °C, compute the stress when the temperature drops to -20 °C. The cross-sectional area of the rod is 1200 mm², $\alpha = 11.7 \mu\text{m}/(\text{m } ^\circ\text{C})$ and $E = 200 \text{ GPa}$, assuming that the (i) walls are rigid, and (ii) walls spring together a total distance of 0.5 mm as the temperature drops. 10

- (c) What do you mean by complementary shear stress? 2

8. (a) Define 'fatigue strength' and 'fatigue life' of steel. 3

- (b) Describe a standard fatigue test to determine the endurance of mild steel material. 7

- (c) Describe the following impact tests clearly indicating the difference between them as regards the specimen and support fixtures for doing the experiment: (i) IZOD test, and (ii) Charpy test. 10

Group C

9. (A) Briefly describe *any five* of the following: 5 × 2

- (i) Generalized Hooke's law
- (ii) Visco-elastic behaviour of materials
- (iii) Toughness of materials and its quantification
- (iv) Strain energy in torsion
- (v) Castigliano's theorem
- (vi) Neutral axis of cross-section of a beam
- (vii) Yield criteria of a metal.

- (B) Choose the *correct* answer and write the letter code accordingly for each of the following: 10 × 1

- (i) The property of a material to sustain large strains at fracture is called

- (a) toughness.
- (b) ductility
- (c) resilience
- (d) yield strength.

- (ii) Torque in a solid shaft of diameter d and shear stress σ_s is given by

- (a) $(\pi/64) \sigma_s d^3$
- (b) $(\pi/32) \sigma_s d^3$
- (c) $(\pi/16) \sigma_s d^3$
- (d) $(\pi/8) \sigma_s d^3$

- (iii) The value of moment of inertia for a solid shaft of diameter d is equal to
- $\pi d^4/32$
 - $\pi d^4/64$
 - $\pi d^4/16$
 - $\pi d^3/32$
- (iv) Maximum shear stress in a body subjected to two perpendicular stresses σ_x , σ_y and shear stress, τ_{xy} , is equal to
- $\sqrt{[(\sigma_x - \sigma_y)/2]^2 + (\tau_{xy})^2}$
 - $(\sigma_x - \sigma_y)/2$
 - $\sqrt{(\sigma_x - \sigma_y)^2 + (\tau_{xy})^2}$
 - $\sqrt{[(\sigma_x - \sigma_y)^2 / 2] + (\tau_{xy})^2}$
- (v) The point of contraflexure is a point where
- shear force is zero.
 - shear force changes sign.
 - bending moment changes sign.
 - bending moment is maximum.
- (vi) Hoop stress in a thin walled cylinder is
- compressive stress.
 - radial stress.
 - circumferential tensile stress.
 - longitudinal stress.
- (vii) The section modulus of a circular section about an axis through the centre of gravity is
- $\pi d^3/16$
 - $\pi d^3/32$
 - $\pi d^3/64$
 - $\pi d^2/32$
- (viii) A beam of length l , having a uniform load w kg per unit length, is supported freely at the ends. The bending moment at mid-span will be
- $wl/4$
 - $wl^2/2$
 - $wl^2/4$
 - $wl^2/8$
- (ix) The property of a material by virtue of which it can be beaten or rolled into plates is called
- malleability.
 - ductility.
 - plasticity.
 - elasticity.
- (x) The principal plane is one which carries
- maximum shear stress.
 - no shear stress.
 - no normal stress.
 - maximum resultant of stresses.

S'11:4 FN:MC 403/PR 403 (1496)**MECHANICS OF SOLIDS***Time : Three hours**Maximum Marks : 100*

*Answer FIVE questions, taking ANY TWO from Group A,
ANY TWO from Group B and ALL from Group C.*

*All parts of a question (a, b, etc.) should
be answered at one place.*

*Answer should be brief and to-the-point and be supplemented
with neat sketches. Unnecessary long answers may
result in loss of marks.*

*Any missing or wrong data may be assumed suitably giving
proper justification.*

Figures on the right-hand side margin indicate full marks .

Group A

1. (a) Three cylinders *A*, *B*, *C* weighing 100 N, 300 N, 200 N, and radii 100 mm, 250 mm, 150 mm, respectively are placed on a rectangular channel of width 500 mm. Neglecting friction, determine the reactions at different contact points. 12

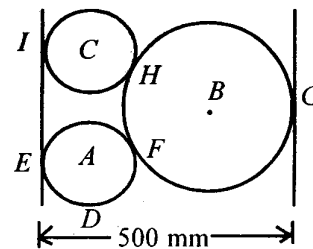

- (b) What effort will be required to apply horizontally to move a body of weight W up along a plane inclined at an angle α with horizontal, if the angle of friction between the body and the plane is ϕ . 8
2. (a) A horizontal beam, with equal overhangs a on both sides, is simply-supported over two supports at a distance l . The beam carries a uniformly distributed load. What should be the ratio between a and l so that magnitude of maximum moment is minimum. 10
- (b) Find the maximum load that can be placed at the centre of a simply-supported rectangular beam 200 mm wide and 300 mm deep of span 4 m, if the maximum permissible bending stress and shear stress are 60 N/mm^2 and 6 N/mm^2 , respectively. 10
3. (a) Derive the expressions for normal stress and shear stress on a plane inclined at Q with x plane when normal stresses in x plane and y plane are σ_x and σ_y , respectively and shear stresses on these planes are τ_{xy} and $-\tau_{xy}$, respectively. 10
- (b) In a two-dimensional stress analysis system, the normal stresses at x plane, y plane and the plane bisecting x and y plane are 100 N/mm^2 , 20 N/mm^2 and 40 N/mm^2 , respectively. Find the principal stress, maximum shear stress and inclination of the principal planes with x plane. 10
4. (a) A 4 m long beam is fixed at both ends. A concentrated load of 5 kN acts at a distance of 1.5 m from the left end. Assuming flexural rigidity to be uniform, draw the shear force and bending moment diagrams. 10
- (b) Estimate (i) Young's modulus of elasticity, (ii) Yield point, (iii) Ultimate stress (nominal), (iv) Ultimate stress (actual), (v) Percentage elongation, and (vi) Percentage reduction of area from the following data on tensile test of a mild steel specimen of dia 25 mm and length 300 mm : 10
- (I) Extension under a load of 10 kN = 0.03 mm
 (II) Load at yield point = 130 kN
 (III) Load at failure = 212 kN
 (IV) Length of specimen at failure = 390 mm
 (V) Neck diameter = 16.75 mm.
- Group B**
5. (a) Find the expressions for circumferential and longitudinal stresses developed in a thin cylinder of length l , radius r and thickness t when both ends are closed and cylinder is subjected to an internal pressure p . Also, find the change in volume, if Young's modulus of elasticity and Poisson's ratio of the material are E and μ , respectively. 12
- (b) A thick cylinder of internal diameter 600 mm and thickness 60 mm is subjected to internal and external pressures of 2 N/mm^2 and 0.1 N/mm^2 , respectively. Find the longitudinal stress. 8

6. (a) A solid circular shaft of 100 mm diameter and 4 m length is fixed rigidly at both ends. At a distance of 1 m from left end, a torque of 25 kN-m is applied. Find the angle of twist of the rod at the point of application of the torque and the maximum shear stress developed in the shaft assuming modulus of rigidity of the shaft material as $8 \times 10^4 \text{ N/mm}^2$. 12
- (b) Derive the expression for stiffness of a closed coil helical spring. 8
7. (a) Write the expressions for generalised Hook's law. 3
- (b) Write the expressions for modulus of rigidity (G) and bulk modulus (K) in terms of Young's modulus of elasticity (E) and Poisson's ratio (μ). Establish the relation between E , K and G . 5
- (c) A rod ABC (length and cross-sectional area of the portion AB are 2 m and 1 cm^2 , respectively and those of the portions BC are 1 m and 0.5 cm^2 , respectively) is fixed between two supports 3 m apart. If the temperature of this rod is increased by 30°C , find the stresses developed in the two portions when the (i) supports are unyielding, and (ii) supports yield by 0.4 mm. 12
8. (a) For an element subjected to a normal stress σ , prove that strain energy stored per unit volume is $\sigma^2/2E$, where E is the Young's modulus of elasticity. Hence, prove that strain energy stored in bending of a flexural member per unit length is $M^2/2EI$, where M is the bending moment at the section and EI , the flexural rigidity. 10

- (b) A cantilever beam of length ' l ' and flexural rigidity EI is loaded with a uniformly distributed load of intensity w . Find the slope and deflection at the free end by using Castigliano's theorem. 10

Group C

9. Choose the most appropriate answer for the following : 20 x 1
- (i) Torsional stiffness of a cylindrical rod of length ' l ', polar moment of inertia of the cross-section about centre J , moment of inertia of the cross-section about diameter I , Young's modulus of elasticity E and modulus of rigidity G is given by
- (a) $3EI/l$
 (b) $4EI/l$
 (c) GJ/l
 (d) GJ
- (ii) The material property, which can be attributed to drawing it a small cross-section by application of tension, is
- (a) plasticity.
 (b) elasticity.
 (c) ductility.
 (d) malleability.
- (iii) At the neutral axis in a rectangular beam, the normal and shear stresses, respectively are
- (a) zero and maximum.
 (b) maximum and zero.
 (c) zero and minimum.
 (d) zero and zero.

(iv) The elongation of a tapered rod of length l , diameters d_1 and d_2 at the ends, Young's modulus E , under a tensile force, T , is given by

(a) $4Tl/\pi d_1 d_2 E$

(b) $8Tl/[\pi (d_1^2 + d_2^2) E]$

(c) $16Tl/[\pi (d_1 + d_2)^2 E]$;

(d) $4Tl/[\pi (d_1^2 + d_2^2 - d_1 d_2) E]$.

(v) The phenomenon of slow extension with time under constant tension is called

(a) plasticity.

(b) yield.

(c) fatigue.

(d) creep.

(vi) A simple beam of span L is loaded by two concentrated loads W each at distance $L/4$ from each end. The maximum bending moment will be

(a) $WL/8$

(b) $WL/4$

(c) $WL/2$

(d) WL

(vii) For beam, if the deflection at section x is y and flexural rigidity of the beam is EI , the shear force at section x is

(a) $(EI) d^2y/dx^2$

(b) $(-EI) d^2y/dx^2$

(c) $(-EI) d^3y/dx^3$

(d) $(EI) d^3y/dx^3$

(viii) If the depth of a beam is halved and width is doubled, the deflection will be

(a) one-fourth.

(b) half.

(c) twice.

(d) four times.

(ix) The angle of twist for a solid circular shaft of length L and diameter D subjected to a torque will be proportional to

(a) TL/D^4

(b) TL/D^3

(c) TD/L^2

(d) TD^3/L

(x) Maximum slope of a cantilever of length L and flexural rigidity EI , subjected to a couple M at free end, will be

(a) $ML/2EI$

(b) ML/EI

(c) $ML^2/2EI$

(d) $ML^2/3EI$

(xi) The equivalent design moment for circular shaft to be designed on the basis of principal stress, when subjected to a bending moment M and a torque T simultaneously, is

(a) $\sqrt{M^2 + T^2}$

(b) $M + \sqrt{M^2 + T^2}$

(c) $\left(M + \sqrt{M^2 + T^2} \right) / 2$

(d) $\sqrt{M^2 + 4T^2}$

- (xii) The maximum shear stress developed in a thin cylindrical shell of radius r and thickness t , when subjected to internal pressure p , will be
- pr/t
 - $pr/2t$
 - $pr/3t$
 - $pr/4t$
- (xiii) For a rectangular beam subjected to bending, the ratio of maximum shear stress and average shear stress is
- 1.25
 - 1.33
 - 1.5
 - 2.0
- (xiv) The ratio of critical loads of two columns of same dimensions, but one fixed at both ends and the other fixed at one end and hinged at the other end, is
- $\sqrt{2}$
 - 2
 - $2\sqrt{2}$
 - 4
- (xv) The equivalent stiffness of three springs of stiffnesses K_1, K_2, K_3 connected in parallel is
- $(K_1 + K_2 + K_3)/3$
 - $K_1 + K_2 + K_3$
 - $3\sqrt{K_1 K_2 K_3}$
 - $1/(1/K_1 + 1/K_2 + 1/K_3)$
- (xvi) The kernel of a rectangular column of sides a and b ($a > b$) is
- rectangle of sides $a/3$ and $b/3$.
 - square of sides $a/3$.
 - square of sides $b/3$.
 - rhombus of sides $\sqrt{a^2 + b^2}/6$.
- (xvii) At the point of contraflexure of a beam,
- shear force changes sign.
 - bending moment changes sign.
 - shear force is maximum.
 - bending moment is maximum.
- (xviii) The stress at a point in an elastic body is a
- scalar.
 - vector.
 - tensor.
 - point function.
- (xix) For a prismatic bar, the ratio of maximum stress developed for cases of sudden application and gradual application of an axial load is
- 0.5
 - 1.0
 - 2.0
 - 4.0
- (xx) The stress level below which the material has high probability of not failing under repeated reversal of stress is called
- elastic limit.
 - proportional limit.
 - tolerance limit.
 - endurance limit.

W'11:4FN: MC403/PR403(1496)**MECHANICS OF SOLIDS***Time : Three hours**Maximum Marks : 100*

*Answer FIVE questions, taking ANY TWO from Group A,
ANY TWO from Group B and ALL from Group C.*

*All parts of a question (a, b, etc.) should
be answered at one place.*

*Answer should be brief and to-the-point and be supplemented
with neat sketches. Unnecessary long answers may
result in loss of marks.*

*Any missing or wrong data may be assumed suitably giving
proper justification.*

Figures on the right-hand side margin indicate full marks.

Group A

1. (a) Explain the phenomenon of sudden stretching of the specimen at the yield point in tension test. 5
- (b) What is strain hardening? How can the undesirable effect of strain hardening be removed? 5
- (c) Differentiate between hardness and toughness. How are these two determined in the laboratory? Explain in brief. 5
- (d) What is ductility of the material? How is the ductility measured? 5

2. (a) A flange coupling, joining two sections of the shaft, is required to transmit 300 kW at 1000 r.p.m. If eight bolts are to be used on a pitch circle diameter of 160 mm, find the diameter of the bolts. Allowable mean shear stress is 80 N/mm^2 . 6
- (b) Two rods *A* and *B* of equal free length hang vertically 60 cm apart and support a rigid bar horizontally. The bar remains horizontal when carrying a load of 5000 kg at 20 cm from rod *A*. If the stress in *B* is 50 N/mm^2 , find the stress in rod *A* and the areas of *A* and *B*. Take $E_A = 200,000 \text{ N/mm}^2$ and $E_B = 90,000 \text{ N/mm}^2$. 8
- (c) What is volumetric stress and volumetric strain? How is the volumetric strain determined when a circular rod is loaded axially? 6
3. (a) A beam AB 3m long, is simply-supported at A and B. It carries a 16 kN concentrated load at C, 1.2 m from A and a uniformly distributed load of 5 kN/m over the remainder (portion CB) of the beam. Draw the shear force and bending moment diagram and determine the value of maximum bending moment. 8
- (b) A beam of 8m span is built in horizontally at the ends and carries a distributed load of 16 kN/m in addition to a concentrated load of 60 kN at 3m from left end. Find the reactions and fixing moments. Draw the resultant bending moment diagram. 12
4. (a) A 75 mm diameter compound bar is constructed by shrinking a circular brass bush on to the outside of a 50 mm diameter solid steel rod. If the compound bar is then subjected to an axial compressive load of 160 kN, determine the load carried by the steel rod and brass bush and the compressive stresses set up in each material. Take $E_{\text{steel}} = 210,000 \text{ N/mm}^2$ and $E_{\text{brass}} = 90,000 \text{ N/mm}^2$. 8
- (b) In a piece of material, a tensile stress, f_1 , and a shearing stress q act on a given plane. Show that the principal stresses are always of opposite sign. 4
- (c) At a point in a material, there are normal stresses of 30 N/mm^2 and 60 N/mm^2 both tensile together with a shearing stress of 22.5 N/mm^2 . Find the values of principal stresses and inclination of principal planes to the direction of the 60 N/mm^2 stress. 8
- Group B**
5. (a) Express stresses σ_x , σ_y and σ_z in terms of strains ϵ_x , ϵ_y and ϵ_z using generalized Hook's law. 5
- (b) A steel rod of cross-sectional area 600 mm^2 and a coaxial copper tube of cross-sectional area 1000 mm^2 are firmly attached at their ends to form a compound bar. Determine the stresses in steel and in the copper when the temperature of the bar is raised by 80°C . Take $E_{\text{steel}} = 200,000 \text{ N/mm}^2$, $E_{\text{copper}} = 100,000 \text{ N/mm}^2$, $\alpha_{\text{steel}} = 11 \times 10^{-6} \text{ per } ^\circ\text{C}$ and $\alpha_{\text{copper}} = 16.5 \times 10^{-6} \text{ per } ^\circ\text{C}$. 10
- (c) What do you understand by plane stress and plane strain problems? Give examples. 5
6. (a) Determine the hoop and longitudinal stresses set-up in a thin boiler cylindrical shell of circular cross-section 5 m long and 1.3 m internal diameter when the internal pressure reaches a value of 240 kN/m^2 . What will then be its change in diameter? The wall thickness of the boiler is 25 mm. Take $E = 210,000 \text{ N/mm}^2$ and $\nu = 0.3$. 6
- (b) Find the ratio of thickness to internal diameter for a thick tube subjected to internal pressure when the ratio of pressure to maximum stress is 0.5. 8

- (c) A steel solid disc of uniform thickness and of diameter 500 mm is rotating about its axis at 3000 r.p.m. Determine the variation of circumferential and radial stresses in the disc. Take $\rho = 7700 \text{ kg/m}^3$ and $\nu = 0.3$. 6
7. (a) A beam of I-section of moment of inertia 954 cm^4 and depth 14 cm is freely supported at its ends. Over what span can a uniform load of 5 kN/m run be carried, if the maximum stress is 60 N/mm^2 ? What additional central load can be carried when the maximum stress is 90 N/mm^2 ? 10
- (b) A flywheel, weighing 500 kg, is mounted on a shaft 75 mm diameter at mid-way between bearings 0.6 m apart. If the shaft is transmitting 30 kW at 360 r.p.m., calculate the principal stresses and the maximum shear stress at the ends of vertical diameter. 10
8. (a) A close coiled helical spring of circular cross-section extends 1mm when subjected to an axial load W and there is an angular rotation of 1 radian when a torque T is independently applied about the axis. If D is mean coil diameter, determine the ratio T/W in terms of D and poisson's ratio ν . 6
- (b) Prove that, in an open coiled helical spring subjected to an axial load, the value of the maximum shear stress is the same as in a close coiled helical spring of the same dimensions. 6
- (c) A rod 1m long is 10 cm^2 in area for a portion of its length and 5 cm^2 in area for the remainder. The strain energy of this stepped bar is 40% of that of a bar 10 cm^2 in area and 1m long under the same maximum axial stress. What is the length of the portion 10 cm^2 in area? 8

Group C

9. Choose the *correct* answer for the following : 10×2

- (i) There is always a limiting value of load up to which the strain totally disappears on the removal of the load. The stress corresponding to this load is called
- (a) elastic limit.
 (b) yield stress.
 (c) proportional limit.
 (d) ultimate stress.
- (ii) Temperature stress developed in a bar depends upon which of the following :
- (a) Coefficient of linear expansion
 (b) Change of temperature
 (c) Modulus of elasticity
 (d) All of the above.
- (iii) In a cantilever beam, carrying a load whose intensity varies uniformly from zero at the free end to w per unit run at the fixed end, the bending moment changes with the following :
- (a) Parabolic law
 (b) Cubic law
 (c) Linear law
 (d) None of the above.
- (iv) The strength of the beam mainly depends on
- (a) bending moment.
 (b) C.G. of the section.

- (c) section modulus.
(d) its weight.
- (v) A fixed beam of length 6 m carries a concentrated point load of 120 kN at its centre. The fixing moment at the ends is
- (a) 40 kN-m
(b) 90 kN-m
(c) 120 kN-m
(d) 150 kN-m
- (vi) In thick cylinders subjected to internal pressure, only maximum stress occurs at
- (a) hoop stress at inner radius.
(b) hoop stress at outer radius.
(c) radial stress at inner radius.
(d) longitudinal stress.
- (vii) The variation of hoop stress across the thickness of a thick cylinder is
- (a) uniform.
(b) parabolic.
(c) linear.
(d) None of the above.
- (viii) The shafts are designed on the basis of
- (a) strength.
(b) rigidity.
(c) either (a) or (b) above.
(d) both (a) and (b) above.
- (ix) An open coiled helical spring is subjected to an axial load. The stresses produced are
- (a) shear stress only.
(b) bending stress only.
(c) shear and bending stresses.
(d) tensile stress only.
- (x) The maximum radial stress in a hollow circular rotating disc of uniform thickness is at
- (a) inner radius.
(b) outer radius.
(c) mean radius.
(d) geometric mean radius.

S'12:4FN:MC 403/PR 403 (1496)**MECHANICS OF SOLIDS**

Time : Three hours

Maximum Marks : 100

*Answer FIVE questions, taking ANY TWO from Group A,
ANY TWO from Group B and ALL from Group C.*

*All parts of a question (a, b, etc.) should
be answered at one place.*

*Answer should be brief and to-the-point and be supplemented
with neat sketches. Unnecessary long answers may
result in loss of marks.*

*Any missing or wrong data may be assumed suitably giving
proper justification.*

Figures on the right-hand side margin indicate full marks.

Group A

1. (a) Cylindrical roller *A*, weighing 1500 kg having diameter 50 cm, and another cylinder roller *B*, weighing 1200 kg having diameter 42 cm, are kept in a horizontal channel of width 72 cm. Curved surface *A* touches the base of the channel and one vertical face of the channel, and curved surface of *B* also touches the other vertical face of the channel. Assuming no friction, find the reaction at all the contact points. 10
- (b) Find the elongation of a tapered bar of length l and radii d_1 and d_2 at the ends under a tension T , if Young's modulus of elasticity of the material is E . 10
2. (a) With the help of Mohr circle, establish the relation between Young's modulus of elasticity, E , modulus of rigidity, G , and Poisson's ratio, μ . 10

(Turn Over)

- (b) In two-dimensional stress analysis, the normal stresses along x plane, y plane and along the plane bisecting these two planes were 100 MPa, 40 MPa and 80 MPa, respectively. Find the principal stresses and maximum shear stress developed. Also, find the inclination of principal planes with x plane. 10
3. (a) A beam AB of length 10 m is simply-supported at left end A and at distance of 9 m from A . The beam is subjected to clockwise couple of 0.9 kN-m at left end A , a concentrated load of 1.8 kN at a distance 1 m from A , a distributed load of intensity 0.45 kN/m from 2 m from A upto right-hand support and a concentrated load of 0.9 kN at right end B . Draw the shear force and bending moment diagram, indicating maximum values and location of the points of contraflexure, if any. 12
- (b) Find the degree of statical indeterminacy for the following cases : 2 + 2
- (i) A beam fixed at both ends
- (ii) A truss with 13 members with 7 nodes supported on two hinges externally.
- (c) State what do you mean by equilibrium equation and compatibility condition. 4
4. (a) Draw a typical stress strain curve for mild steel under tension, describing briefly the salient points. 10
- (b) A bar of length 3 m is fixed rigidly at both ends. The cross-sectional area is 100 mm² throughout. At a distance of 1 m from left end, a force of 20 kN is applied along its axis towards right. Compute the thrust at supports taking $E = 2.1 \times 10^5$ N/mm². Also, find the stress developed in different portions. 10

S'12:4FN:MC403/PR403 (1496) (2)

(Continued)

Group B

5. (a) Given Young's modulus of elasticity $E = 2 \times 10^5$ N/mm² and Poisson's ratio $\mu = 0.5$, find the normal strains developed in x , y and z directions, if the normal stresses developed in these directions are 120 MPa, 60 MPa and -80 MPa, respectively. 6
- (b) For a 1 m long uniform metallic rod with $E = 2 \times 10^5$ N/mm² and $\alpha = 1.2 \times 10^{-6}/^\circ\text{C}$, fixed at both ends, determine the stress developed in the member for a temperature rise of 40 °C, if the cross-sectional area of the rod is 100 mm² and also the support reactions. 6
- (c) A solid rectangular beam of width 100 mm and depth 200 mm is 4 m long and simply-supported at its ends. If this beam is subjected to a uniformly distributed load of intensity 1 kN/m, find the maximum bending stress and shear stress developed in the beam. 8
6. (a) A pipe of 400 mm internal diameter and 560 mm external diameter contains a fluid at a pressure of 100 N/mm². Find the maximum and minimum hoop stresses developed and also the radial pressure at a distance of 240 mm from the centre. 8
- (b) A cylindrical shell, with internal diameter of 1 m and thickness of 10 mm, is subjected to an internal pressure of 80 N/mm². Estimate the maximum shear stress developed in the shell. 2
- (c) A thin uniform steel disc of diameter 40 cm is rotating about its axis at 1200 revolutions per minute. Assume density of steel as 7850 kg/m³, $g = 981$ m/sec² and Poisson's ratio of steel as 0.3. Find radial stress and circumferential stress at centre and at outer periphery. 10

S'12:4FN:MC403/PR403 (1496) (3)

(Turn Over)

7. (a) A hollow circular shaft of 200 mm internal diameter and thickness 50 mm transmits power at 200 rpm. The angle of twist over a length of 1 m is found to be 0.5 degree. Calculate the maximum shear stress developed and the power transmitted. Take $G = 0.8 \times 10^5$ N/mm². 8
- (b) If solid bar of 100 mm dia is replaced by a hollow bar of internal diameter 100 mm with same cross-sectional area and of the same material, find the percentage increase in allowable torque. 6
- (c) A closed coil helical spring is made with 12 mm dia wire having a mean diameter 160 mm and 10 complete turns. Find the maximum shear stress developed and the deflection when a load of 400 N is applied. Modulus of rigidity of the wire may be taken as 0.84×10^5 N/mm². 6
8. (a) A cantilever beam of 3 m length is subjected to a concentrated load P in addition to a uniformly distributed load of intensity w over the entire length. Calculate the strain energy stored in the beam. Assume flexural rigidity to be EI uniform over the length. 8
- (b) A solid circular shaft is subjected to a bending moment of 50 kN-m and a torque of 10 kN-m. Design the diameter of the shaft by using the theory of maximum (i) principal stress, (ii) shear stress, and (iii) strain energy. Assume Poisson's ratio as 0.3, yield stress as 250 N/mm², and a factor of safety of 1.5. 12

Group C

9. Choose the *correct* answer for the following : 10 × 2
- (i) A transversely loaded beam will be unstable, if the end supports are
- (a) one hinge other roller.

- (b) both hinged.
- (c) both roller.
- (d) one fixed and other hinged.
- (ii) For a thin cylinder of radius r and thickness t , subjected to an internal pressure p , the maximum radial pressure is
- (a) p
- (b) pr/t
- (c) $pr/2t$
- (d) negligible.
- (iii) A thin rim of radius r is rotating about its axis at an angular speed w rad/sec. If the specific weight of the material is γ , the maximum stress developed is
- (a) $\gamma w^2 r^2 / g$
- (b) $\gamma w^2 r^2 / 2g$
- (c) $\gamma w^2 r^2$
- (d) $\gamma g w^2 / r^2$
- (iv) If instead of gradual development a tensile load is suddenly applied, the maximum stress developed will be
- (a) same.
- (b) half.
- (c) double.
- (d) triple.
- (v) If, in a beam, a single load P is applied gradually and the deflection under the load point is δ , the strain energy stored in the beam will be
- (a) $P\delta$
- (b) $P\delta/2$
- (c) $P\delta^2$
- (d) $P\delta^2/2$

S'12:4FN:MC403/PR403(1496) (4)

(Continued)

S'12:4FN:MC403/PR403(1496) (5)

(Turn Over)

- (vi) If the total length of the wire in a spring is fixed and mean radius of the helical spring is doubled, its stiffness will be
- (a) half.
 - (b) one-fourth.
 - (c) one-eighth.
 - (d) one-sixteenth.
- (vii) Maximum principal stress theory and maximum shear stress theory of failure respectively are suitable for materials
- (a) ductile and brittle
 - (b) brittle and ductile
 - (c) only ductile
 - (d) only brittle.
- (viii) Amongst the different theories of failure, the failure criteria is not correctly predicted by the theory of maximum
- (a) strain energy.
 - (b) distortion strain energy.
 - (c) principal stress.
 - (d) shear stress.
- (ix) For thick cylinders subjected to internal pressure, only the magnitudes of radial and circumferential stresses, respectively are maximum at periphery
- (a) inner and outer.
 - (b) outer and inner.
 - (c) both inner.
 - (d) both outer.

- (x) If, in a three-dimensional analysis, the principal stresses are p_1 , p_2 and p_3 (where $p_1 > p_2 > p_3$), the magnitude of maximum shear stress will be

- (a) $(p_1 + p_2 + p_3)/3$
- (b) $(p_1 - p_2)/2$
- (c) $(p_1 - p_3)/2$
- (d) $(p_2 - p_3)/2$

W'12:4FN : MC403/PR403 (1496)**MECHANICS OF SOLIDS***Time : Three hours**Maximum Marks : 100*

*Answer FIVE questions, taking ANY TWO from Group A,
ANY TWO from Group B and ALL from Group C.*

*All parts of a question (a, b, etc.) should
be answered at one place.*

*Answer should be brief and to-the-point and be supplemented
with neat sketches. Unnecessary long answers may
result in loss of marks.*

*Any missing or wrong data may be assumed suitably giving
proper justification.*

Figures on the right-hand side margin indicate full marks.

Group A

1. (a) Define hardness. What is the necessity of hardness testing? Describe *any one* method to find hardness of a given material. 5
- (b) What is a gauge length? What factors should be considered in selecting the gauge length in tensile testing? 5
- (c) Define shear. Differentiate between single and double shear with examples. 5
- (d) Differentiate between ductile and brittle materials. How is the ductility measured? 5
2. (a) A bar of uniform cross-sectional area ' A ' and length ' L ' hangs vertically from a rigid support of the density

- of a material of the bar as $\rho \text{ kg/m}^3$. Derive the expression for maximum stress induced and elongation produced in the bar due to its own weight. 8
- (b) If the tension test bar is found to taper from $(D + a)$ cm diameter to $(D - a)$ cm diameter, prove that the error involved in using the mean diameter to calculate Young's modulus is $(10 a/D)^2$ percent. 8
- (c) Define the terms shear stress, shear strain, bulk modulus and Poisson's ratio. 4×1
3. (a) A beam AB , 15 m long, is simply-supported at points C and D , 10 m apart, the overhangs AC and DB being 2 m and 3 m, respectively. The beam carries a distributed load of 20 kN/m over the whole length along with a load of 50 kN at A and 80 kN at B . Draw to scale the SF and BM diagrams giving maximum values and stating wherefrom these occur. Also, find the points of contraflexure. 10
- (b) How are the distributions of loading the shear force and bending moment related to each other? Are there any pre-conditions for the relationship? 3
- (c) A built-in beam of span 10 m carries a U.D.L. of 15 kN/m on the entire span along with two point loads of 200 kN each at distances of 3 m and 7 m from left end. Find the fixing moment and the deflection at the centre. 7
4. (a) A brass tube of 20 mm internal diameter and 20 mm external diameter surrounds a 18 mm shank of a steel bolt. After putting rigid washers on the two sides of the tube, the nut is rotated such that it is just tight and no load is exerted on the tube by the washers. The length of the tube is 200 mm. The temperature is then raised to 270°C . If the room temperature is 20°C , find the increase in the stresses in brass and steel. Given : $\alpha_b = 18.7 \times 10^{-6}/^\circ\text{C}$, $\alpha_s = 11.6 \times 10^{-6}/^\circ\text{C}$, $E_b = 100 \text{ GPa}$, $E_s = 200 \text{ GPa}$. 10
- (b) A straight bar of uniform cross-section is loaded in axial tension. Determine the normal and shearing stress intensities on a plane inclined at an angle θ° to the axis of the bar. Also, determine the magnitude and direction of the maximum shearing stress in the bar. 6
- (c) Using Mohr's circle, derive an expression for normal and tangential stresses on a diagonal plane of a material subjected to pure shear. 4
- Group B**
5. (a) What is the relation of stress-strain in three-dimensional body? 6
- (b) Derive compatibility equations for plane strain distribution in cartesian co-ordinates. 4
- (c) A copper sleeve, 21 mm internal and 27 mm external diameter, surrounds a 20 mm steel bolt, one end of the sleeve being in contact with the shoulder of the bolt. The sleeve is 60 mm long. After putting a rigid washer on the other end of the sleeve, a nut is screwed on the bolt through 10° . If the pitch of the threads is 2.5 mm, find the stresses induced in the copper sleeve and steel bolt. Take $E_s = 200 \text{ GN/m}^2$ and $E_c = 90 \text{ GN/m}^2$. 10
6. (a) A spherical vessel of 0.75 m diameter is made from 11 mm steel plate and is just filled with water at atmospheric pressure. When an additional 0.00088 J m^3 of water is pumped in, the pressure rises to 5.8 MN/m^2 (gauge). Find the bulk modulus of water. For steel, take $E = 200 \text{ GN/m}^2$ and Poisson's ratio = 0.286. 8

- (b) A flat disc made up of steel, having a diameter of 1.2 m, rotates at a speed of 2700 rpm. Determine the intensities of radial and hoop stresses at the external fibre. Take $\rho = 7.80 \times 10^3 \text{ kg/m}^3$ and $\nu = 0.292$. 8
- (c) Find the ratio of thickness to internal diameter for a tube subjected to internal pressure when the ratio of internal pressure to the greatest circumferential stress is 0.5. 4
7. (a) A hollow shaft of diameter ratio 0.6 is required to transmit 1500 kW at a speed of 2500 rpm. It is to be fitted with a flanged coupling having 8 bolts on a circle of diameter twice that of the shaft. If the allowable shear stress in the shaft and bolts are 70 MN/m² and 55 MN/m², respectively, find the shaft and bolt diameters. 10
- (b) A solid phosphor-bronze shaft of 50 mm diameter is rotating at 740 r.p.m. It is subjected to torsion only. An electrical resistance strain gauge is mounted on the surface of shaft with its axis at 45° to the shaft axis, gives the strain reading as 417×10^{-4} . Find the power being transmitted if the modulus of elasticity for bronze is 105000 MN/m². Take $\nu = 0.3$. 10
8. (a) A rectangular section ($b \times d$) cantilever of length l carries uniformly distributed load from free end to the mid-section of the cantilever. Find the deflection due to shear at the free end. 8
- (b) A closed coiled helical spring of circular section extends by 1 mm when subjected to an axial load W , and there is an angular rotation of 0.5 radian when a torque, T , is independently applied about the axis. If D is the mean coil diameter, show that
- $$\frac{T}{W} = \frac{D^2 (1 + \nu)}{8}$$
- where ν is the Poisson's ratio. 8

- (c) State the assumptions made while deciding the yield criteria for metals. Explain any one yield criteria for yielding to occur. 4

Group C

9. Explain the following: 5 × 4
- Generalised Hooke's law
 - Izod impact test
 - Plane stress and plain strain problems
 - Elastic, plastic and visco-elastic materials
 - Strain hardening of metals.

S'13: 4 FN:MC 403/PR 403 (1496)**MECHANICS OF SOLIDS***Time : Three hours**Maximum Marks : 100*

*Answer FIVE questions, taking ANY TWO from Group A,
ANY TWO from Group B and ALL from Group C.*

*All parts of a question (a,b,etc.) should
be answered at one place.*

*Answer should be brief and to-the-point and be supplemented
with neat sketches. Unnecessary long answers may
result in loss of marks.*

*Any missing or wrong data may be assumed suitably giving
proper justification.*

Figures on the right-hand side margin indicate full marks.

Group A

1. (a) Distinguish between statically determinate and statically indeterminate beams. 4
- (b) A cantilever beam of uniform flexural rigidity EI and length l is loaded by a concentrated load W at the mid-span, whereas the cantilever is propped at the free end. Level of the prop is the same as that of the fixed end. Determine the reaction at the prop. Also, draw the shear force and bending moment diagrams. 8
- (c) A restrained beam AB carries a point load W at a distance a from support A and b from support B. If both the supports are at the same level, determine the end moments and sketch the SFD and BMD. The beam is fixed rigidly at both ends. 8

2. (a) A rod of square section of side D at one end tapers to a square section at the other end. If its length is l , find the increase in length if it is subjected to an axial pull P . 8
- (b) A horizontal bar AB , assumed to be rigid, is supported by two identical wires CE and DF (Fig. 1). If each wire has cross-sectional area A , determine the tensile stresses σ_1 and σ_2 in wires CE and DF , respectively. 12

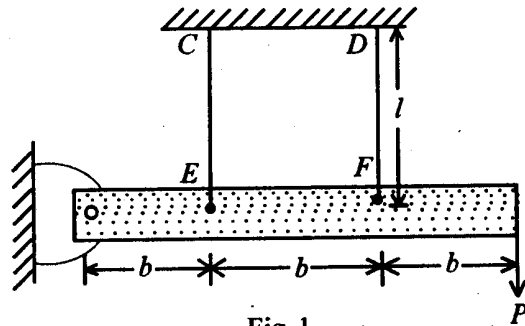

Fig. 1

3. (a) Define 'fatigue strength' and 'fatigue life' of steel. 2
- (b) Describe a standard fatigue test to determine the endurance limit of mild steel material. 8
- (c) Describe the following impact tests clearly indicating the difference between them as regards the specimen and support fixtures for doing the experiment : 5 + 5
- (i) IZOD test
- (ii) CHARPY test
4. (a) Describe the graphical method of Mohr's circle construction for evaluation of principal stresses and principal planes. 10
- (b) A state of stress in a piece of elastic material is given by $\sigma_x = 800$ MPa, $\sigma_y = -600$ MPa, and $\tau_{xy} = \pm 500$ MPa. Find the (i) principal stresses and the position of the

planes on which they act; and (ii) position of the planes on which there is no normal stress. Solve the problem analytically using transformation equations. 10

Group B

5. (a) Enumerate the difference between thin and thick cylinders under internal pressure. 4
- (b) Derive the expressions for hoop and longitudinal stresses for a thin cylinder of internal diameter d , material thickness t , and subjected to internal fluid pressure p . 6
- (c) A thick cylinder of steel, having an internal diameter of 10 cm and an external diameter of 20 cm, is subjected to an internal pressure of 80 MPa and an external pressure of 10 MPa. Find the maximum normal and shearing stresses in the cylinder and calculate the change of external diameter. Given : $E = 200$ GPa and Poisson's ratio = 0.3. 10
6. (a) A steel bar, 4 cm in diameter and 5 m long, is heated through 60°C with ends clamped before heating. Estimate the thrust exerted by the steel bar on the clamps. Given : $E = 210$ GPa and coefficient of thermal expansion, $\alpha = 11 \times 10^{-6}$ per $^\circ\text{C}$. If the clamps have yielded by 0.05 cm, what would be the thrust exerted ? 8
- (b) Write and explain the generalized Hooke's law for an isotropic material. 4
- (c) A mild steel bar, 6 m long, is 5 cm in diameter for 3 m of its length and 2.5 cm in diameter for the remaining length. The bar is in tension and the stress on the smallest section is 112 MPa. Find the total elongation of the bar and the change in diameter at the smallest section. Given : $E = 200$ GPa and Poisson's ratio = 0.15. 8

7. (a) Describe the 'Tresca' yield criterion. Show the failure envelope in a two-dimensional stress space. 4
- (b) Distinguish between plane stress and plane strain problems of elasticity. Give one example each for both. 6
- (c) Enumerate the following for two-dimensional problems of elasticity: 10
- Differential equations of equilibrium
 - Boundary conditions
 - Compatibility equations
 - Airy's stress function and the bi-harmonic equation.
8. (a) Two shafts of the same material and same lengths are subject to the same torque. If the first shaft is of solid circular section and the second shaft is of hollow circular section, whose internal diameter is two-third of the outside diameter, and the maximum shear stress developed in each is the same, compare the weights of two shafts. 10
- (b) A close coiled helical spring, made out of 8 mm diameter wire, has 18 coils. Each coil is of 8 cm mean diameter. If the maximum allowable shear stress in the spring is 140 MPa, determine the maximum allowable load on the spring and elongation of the spring. Also, determine the stiffness of the spring. Take $G = 82$ GPa. 10

Group C

9. (A) Briefly describe the following: 5 × 2
- Stress-strain curve for mild steel showing salient points.

- Castigliano's theorem
- Moment area theorem
- Toughness of materials and their quantification
- Visco-elastic behaviour of materials.

(B) Choose the *correct* answer for the following: 5 × 2

- A state of stress is shown as below:

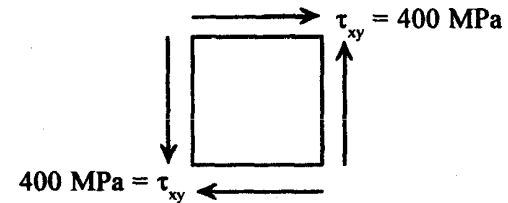

The principal stresses at the point are:

- $\sigma_1 = -400$ MPa, $\sigma_2 = -400$ MPa
 - $\sigma_1 = \sigma_2 = 400$ MPa
 - $\sigma_1 = 800$ MPa, $\sigma_2 = -800$ MPa
 - $\sigma_1 = 400$ MPa, $\sigma_2 = -400$ MPa.
- Tresca's yield criterion refers to
 - maximum octahedral shear stress.
 - maximum shear stress.
 - maximum normal stress.
 - maximum strain energy.
 - Identify the Goodman law for fatigue design:
 - $(\sigma_m / \sigma_u) + (\sigma_a / \sigma_e) = 1$.
 - $(\sigma_m / \sigma_u)^2 + (\sigma_a / \sigma_e) = 1$
 - $(\sigma_m / \sigma_y) + (\sigma_a / \sigma_e) = 1$
 - $(\sigma_m / \sigma_y)^2 + (\sigma_a / \sigma_e)^2 = 1$

(iv) A close coiled helical spring of mean coil radius R , coil wire diameter d is acted upon by a direct compression load W . The maximum shear stress induced in the spring wire is

(a) $\tau_{\max} = 8 WR/\pi d^3$

(b) $\tau_{\max} = 16 WR/\pi d^3$

(c) $\tau_{\max} = 4 WR/\pi d^3$

(d) $\tau_{\max} = 24 WR/\pi d^3$

(v) A simply-supported beam of span L and flexural rigidity EI is acted upon by a concentrated load W at the mid-span. The maximum deflection of the beam is

(a) $WL^3/4 EI$

(b) $WL^3/3 EI$

(c) $WL^3/48 EI$

(d) $WL^3/8 EI$

W'13: 4FN:MC 403/PR403 (1496)**MECHANICS OF SOLIDS**

Time : Three hours

Maximum Marks : 100

Answer FIVE questions, taking ANY TWO from Group A, ANY TWO from Group B and ALL from Group C.

All parts of a question (a,b,etc.) should be answered at one place.

Answer should be brief and to-the-point and be supplemented with neat sketches. Unnecessary long answers may result in loss of marks.

Any missing or wrong data may be assumed suitably giving proper justification.

Figures on the right-hand side margin indicate full marks.

Group A

1. (a) A block weighing 50 N is placed on a plane inclined at 45° with horizontal, the coefficient of friction between the plane and the block being 0.5. The block is attached with an inextensible string passing over a smooth pulley, the other end of the string being vertical and attached with a weightless pan over which weights can be placed. Find the range of values of the weight, W , which can be placed on the said base so that the block does not move on the plane. 14
- (b) Find the force required to be applied horizontally at the level of the centre of a sphere of radius 30 cm and weight 1 kN across a hump of 6 cm high on a horizontal road. 6

2. (a) A right circular solid cone of radius r at the base and height h is hanging with its apex downward and axis vertical with its base fixed with a horizontal plane. Find the extension of the cone under its self-weight, if Young's modulus and density of the cone material are E and ρ , respectively. 10
- (b) Find the shortening of a solid truncated cone of length l and diameters d_1 and d_2 at two ends under an axial compression C , if Young's modulus of elasticity of the material is E . 10
3. (a) A beam ABCD of length 10 m is simply-supported at two supports B and C of 8 m apart with overhangs BA of 1.5 m on left side and CD of 0.5 m on right side. In addition to a uniformly distributed load of intensity 10 kN/m over BC, a clockwise couple 14 kN-m at a distance of 4.5 m from A, a vertical downward load 5 kN at A and a vertical downward load of 10 kN at D are acting on this beam. Draw the shear force and bending moment diagram indicating the salient features. 12
- (b) A beam of length l , uniform flexural rigidity is fixed at its left end and simply-supported at right end is subjected to a transverse load P at a distance a from left end. Draw the shear force and bending moment diagram. 8
4. (a) The cross-sectional area of AB of length $2l$ over its left half is twice that of the right half. The bar is rigidly fixed at its end and is subjected to a force P at the centre acting rightwards along its axis. Find the support reactions. 7
- (b) In a two-dimension case, the longitudinal strains in x plane, y plane and a plane inclined equally to x and y

plane are respectively 8×10^{-4} , 2×10^{-4} and 6×10^{-4} . Find the principal strains and magnitude of maximum shear strain. 7

- (c) The normal stresses in a two-dimensional stress analysis in two mutually perpendicular planes are 100 MPa (tensile) and 80 MPa (compressive) and magnitude of shear stress on these planes is 40 MPa. Find the principal stresses, principal planes and magnitude of maximum shear stress. 6

Group B

5. (a) Find safe RPM of a 2 m diameter thin uniform circular ring of cross-sectional area 1 cm, if the density of material and permissible tensile stress respectively are 7850 kg/m^3 and 144 N/mm^2 , respectively. 8
- (b) A thin uniform solid circular disc of diameter 40 cm is rotating about its axis at 1200 rpm. Calculate the maximum principal stress and shear stress developed in the disc assuming density and Poisson's ratio of the disc are 7850 kg/m^3 and 0.3, respectively. What will be the above values, if in this disc a central hole is made of diameter 10 cm? 12
6. (a) A thin cylindrical shell of 0.6 m dia, 1 m long with shell thickness 3 mm with both ends closed contains a fluid at a gauge pressure of 0.9 MPa. Assuming the outside atmospheric pressure at 0.1 MPa, find the hoop stress and longitudinal stress developed in the shell. Derive the formula used, if any. Also, find the maximum shear stress developed. 10
- (b) A thick cylindrical shell closed at both ends is made of 5 cm thick plate to contain a gas at a pressure of 5.0 N/mm^2 . If the internal diameter of this shell is

30 cm, find (i) longitudinal stress, (ii) radial stress at radius 17.5 cm, and (iii) hoop stress just inside and outside of this shell. 10

7. (a) A hollow shaft is used to transmit a torque of 100 Nm. If the permissible shear stress is 70 MPa and permissible twist is 3° per metre length, find the inside and outside dimension of this shaft taking modulus of rigidity as 80 GPa. 10
- (b) For a closed coil helical spring made of a 3 mm dia wire with 3 cm mean radius and 25 number of turns, calculate the safe load of the spring, if the permissible shear stress is 140 MPa. Also, find the corresponding maximum deflection taking modulus of rigidity of the spring material as 84 GPa. 10
8. (a) A simply-supported uniform solid rectangular beam of span 5 m carries a uniformly distributed load of intensity 8 kN/m. If the permissible bending and shear stresses are 130 MPa and 10 MPa, respectively, determine the dimension of the beam. 10
- (b) A solid circular shaft of diameter 10 cm is subjected to a maximum torque of 16 kN-m and a maximum bending moment of 20 kN-m simultaneously at a critical section. If the elastic limit in simple tension is 250 N/mm^2 , find the factors of safety as per (i) maximum principal stress, and (ii) maximum stress theories of elastic failure. 10

Group C

9. Choose the most appropriate answer for the following : 10×2
- (i) The number of independent elastic constants for a homogeneous isotropic material is

- (a) 1
(b) 2
(c) 3
(d) 9

(ii) If a composite bar of copper and steel is cooled, then the copper bar will be under

- (a) tension.
(b) compression.
(c) shear.
(d) torsion.

(iii) The correct relation ultimate stress (U), actual breaking stress (A), and nominal breaking stress (N) is given by

- (a) $U > A > N$
(b) $A > U > N$
(c) $N > A > U$
(d) $A > N > U$

(iv) In Charpy and Izode impact tests respectively, the specimens are supported as

- (a) simply-supported and cantilever.
(b) cantilever and simply-supported.
(c) simply-supported in both cases.
(d) cantilever in both cases.

(v) Limit of proportionality depends upon

- (a) cross-sectional area.
(b) type of loading.
(c) type of material.
(d) All of the three above.

You may [download prospectus](#) to buy excellent study material for AMIE exams.

You will also get **full access to our online support** with our course which includes latest AMIE question papers, model test papers, eBooks, audio and video lectures, course updates and interactive objective questions.

AMIE(I) Study Circle

Website: www.amiestudycircle.com

WhatsApp: 9412903929

Email: info@amiestudycircle.com