



**W'05 : 3 FN : AN 205 (1405)**

**MECHANICAL SCIENCE**

*Time : Three hours*

*Maximum marks : 100*

**Answer FIVE questions, taking ANY TWO from Group A,  
ANY TWO from Group B and ALL from Group C.**

*All parts of a question (a, b, etc) should be  
answered at one place.*

*Answer should be brief and to-the-point and be supple-  
mented with neat sketches. Unnecessary long answers  
may result in loss of marks.*

*Any missing data or wrong data may be assumed suitably  
giving proper justification.*

*Figures on the right-hand side margin indicate full marks.*

**Group A**

1. (a) Find the initial velocity  $v_0$  with which a projectile would have to be thrown out at the surface of the earth so that it rises to infinite height. Neglect air resistance, and take the radius of the earth 6336 km. 6
- (b) A particle starts from rest and moves along a straight line with constant acceleration. If it acquires a velocity of 3.0 metre per second after having travelled a distance of 7.5 metre, find the magnitude of the acceleration. 7

*Turn Over*

(c) A right circular disk, which weighs 136 kilogram and is 76.2 cm in diameter, is free to rotate about its geometric axis and is constantly accelerated from rest to 300 rpm in 20 seconds. Determine the constant torque required to produce this acceleration. 7

2. (a) A square hole is punched out of a circular lamina, the diagonal of the square being the radius of the circle. Find the CG of the remainder, if  $r$  is the radius of the circle. The diagonal of the square is on a radius of the circle. 6

(b) A weight of 31.5 Newton produces a static deflection of 3.0 cm in a given spring. Determine the period of vibration of a weight of 45 Newton suspended by the same spring. 7

(c) A man of weight 675 Newton stands on the middle rung of a ladder of weight 225 Newton, as shown in Figure 1. The floor and the wall being perfectly smooth, the slipping is prevented by a string DE; find the tension in the string and also the reactions  $R_a$  and  $R_b$  at A and B. 7

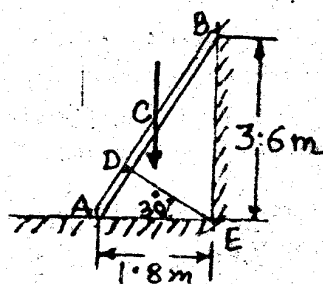

FIG. 1

3. (a) A slender prismatic bar AB of length  $l$  and weight  $Q$  stands in a vertical plane and is supported by smooth surfaces A and B as shown in Fig. 2 Using the principle of virtual work, find the magnitude of the horizontal force  $P$  applied at A to keep the bar in equilibrium. 6

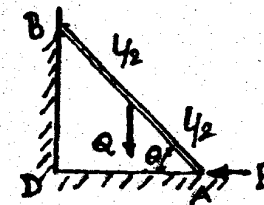

FIG. 2

(b) The mean radius of a screw of a square threaded screw jack is 2.5 cm. The pitch of the thread is 7.5 mm. If the coefficient of friction is 0.12, what effort is applied at the end of a lever of 60 cm in length is needed to raise a weight of 20 kN? 7

(c) Calculate the membrane stresses for a cylindrical tank of radius  $r$ , length  $l$ , and thickness  $t$ , if it carries a uniform internal pressure  $p$ . 7

4. (a) Write the shear and moment equations for the beam loaded as shown in Fig. 3. Sketch the shear force and bending moment diagrams. 10

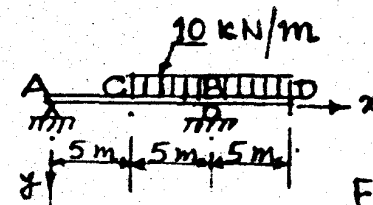

FIG. 3

- (b) A simply supported prismatic beam  $AB$  carries a uniformly distributed load of  $10.0 \text{ kN/m}$ , over its span of length  $10.0 \text{ m}$ . Develop the equation of the elastic line i.e., the equation to the deflected shape of the beam. You may assume the general equation to the elastic line, viz.,

$$\frac{d^2 y}{dx^2} = -\frac{M}{EI}$$

The terms have their usual meaning. 10

### Group B

5. (a) Determine the intensity of shear stress in an oil which is used for lubricating the clearance between a shaft of diameter  $10 \text{ cm}$  and its journal bearing. The clearance is  $1.5 \text{ mm}$  and the shaft rotates at  $150 \text{ rpm}$ . The viscosity of oil is  $1 \text{ poise}$ . 6
- (b) Calculate the capillary rise in glass tube of  $2.5 \text{ mm}$  diameter when immersed vertically in mercury. Take surface tension  $\sigma = 0.52 \text{ gm/cm}$  for mercury in contact with air. The specific gravity of mercury is  $13.6$  and angle of contact is  $130^\circ$ . 7
- (c) Determine the total pressure on a circular plate of diameter  $1.5 \text{ m}$  which is placed vertically in water in such a way that the centre of the plate is  $3.0 \text{ m}$  below the free surface of water. Find also the position of the centre of pressure. 7
6. (a) A pipe of diameter  $30 \text{ cm}$ , conveying water, branches into two pipes of diameters  $20 \text{ cm}$  and  $15 \text{ cm}$ . If the average velocity in the  $30 \text{ cm}$  pipe is  $2.5 \text{ m/sec}$ , find the discharge in this pipe. Also, determine the velocity in  $15 \text{ cm}$  pipe, if the average velocity in  $20 \text{ cm}$  pipe is  $2.0 \text{ m/sec}$ . 6

- (b) Pressure vessels of  $10 \text{ cubic metre}$  are used for storing oxygen, nitrogen, and carbon dioxide at a pressure of  $15 \text{ technical atmosphere}$  and a temperature of  $40^\circ\text{C}$ . Determine the weight of each gas that can be stored in the tank. 7

- (c) A gas of volume  $2.5 \text{ cubic metre}$  at a pressure of  $80 \text{ N/cm}^2$  and  $180^\circ\text{C}$  is heated at constant pressure until the volume is doubled. The specific heats of the gas are:  $C_p = 0.239$  and  $C_v = 0.169$ . Determine the change in internal energy and the external work done during the process. 7

7. (a) Steam is supplied to a fully loaded  $100 \text{ h.p.}$  turbine at  $150 \text{ N/cm}^2$  with an enthalpy of  $701 \text{ kcal/kg}$  and specific volume of  $0.16 \text{ m}^3$  and velocity of  $110 \text{ m/sec}$ . Exhaust takes place at  $0.5 \text{ N/cm}^2$  with enthalpy of  $490 \text{ kcal/kg}$  and specific volume of  $26 \text{ m}^3$  and velocity of  $300 \text{ m/sec}$ . Heat loss from the steam in the turbine is  $5 \text{ kcal/kg}$ . The change in potential energy is negligible. Determine:

(i) the shaft work output per kg

(ii) steam flow rate in  $\text{kg/hr}$ . 6

- (b) A heat engine is supplied with  $278 \text{ kcal/sec}$  of heat at a fixed temperature of  $283^\circ\text{C}$  and the heat rejection takes place at  $5^\circ\text{C}$ . The following data were noted for three different cases:

(i)  $208 \text{ kcal/sec}$  heat rejected

(ii) 139 kcal/sec heat rejected

(iii) 70 kcal/sec heat rejected.

State with justification which case report a reversible cycle, or irreversible cycle or impossible result. 7

(c) Air is compressed in a reversible isothermal steady flow process from  $10.3 \text{ N/cm}^2$  and  $40^\circ\text{C}$  to  $103 \text{ N/cm}^2$ . Determine the work done on the gas per kg and the heat transferred. Also, determine the change of entropy per kg of the mass flow. Assume  $R = 29.27 \text{ kg/m/kg}^\circ\text{K}$ . 7

8. (a) Calculate the thermal efficiency of an engine working an Otto cycle. The bore and stroke of the cylinder are 17 cm and 30 cm respectively. The clearance volume is  $0.002025 \text{ m}^3$ . Assume  $\gamma = 1.4$ . 6

(b) For the same compression ratio and the same heat added Otto cycle is more efficient than Diesel cycle. Justify the statement. 6

(c) Briefly describe the principle of operation of a petrol engine. 8

### Group C

9. Choose the correct answer and write only the letter code in the answer book:  $1 \times 20$

(i) The relation between linear acceleration ( $f$ ) and angular acceleration ( $\alpha$ ) is given by

(a)  $\alpha = f \times r$

(b)  $\alpha = \frac{f}{r}$

(c)  $\alpha = \frac{1}{f \times r}$

(d)  $\alpha = \frac{r}{f}$

(ii) The expression  $\left(\frac{1}{2} I \omega^2\right)$  represents

(a) centrifugal force

(b) kinetic energy

(c) kinetic energy of rotation

(d) potential energy

(iii) The path traced by a projectile in space is

(a) hyperbola

(b) parabola

(c) linear

(d) none of the above

(iv) The coefficient of friction ( $\mu$ ) in terms of angle of friction ( $\phi$ ) is given by

(a)  $\phi = \tan \mu$

(b)  $\mu = \sin \phi$

(c)  $\mu = \tan \phi$

(d)  $\mu = \frac{1}{\tan \phi}$

(v) Self locking machine is one which has an efficiency

- (a) 100%
- (b) less than 50%
- (c) more than 50%
- (d) none of the above

(vi) The tensile force ( $P$ ) acting on a body of length ( $l$ ) and cross-sectional area ( $A$ ). The change in length will be

- (a)  $\frac{P}{IAE}$
- (b)  $\frac{PE}{AI}$
- (c)  $\frac{Pl}{AE}$
- (d)  $\frac{Al}{PE}$

(vii) The stress due to suddenly applied load as compared to the stress due to the same load gradually applied to the same rod is

- (a) half
- (b) same
- (c) double
- (d) three times

(viii) The radius of a Mohr's circle is

- (a) the sum of the two principal stresses
- (b) the difference of two principal stresses
- (c) half of the difference of two principal stresses
- (d) half of sum of two stresses

(ix) A cantilever of length ( $l$ ) carries a point load ( $w$ ) at the free end. The bending moment diagram will be

- (a) parabola with maximum ordinate at the centre of the beam
- (b) parabola with maximum ordinate at the cantilever end
- (c) triangle with maximum ordinate at the free end
- (d) triangle with maximum ordinate at the cantilever end

(x) A simply supported beam of span ( $l$ ) carries a uniformly distributed load over the whole span. The shear force diagram will be

- (a) a rectangle
- (b) a triangle
- (c) two equal and opposite rectangles
- (d) two equal and opposite triangles

(xi) Bernoulli's theorem deals with the law of conservation of

- (a) mass
- (b) momentum
- (c) energy
- (d) none of the above

(xii) Centre of pressure of a plane surface immersed in a liquid is

- (a) above the centre of gravity of the plane surface
- (b) at the centre of gravity of the plane surface
- (c) below the centre of gravity of the plane surface
- (d) none of the above

(xiii) Manometer is a device used for measuring

- (a) velocity at a point in a fluid
- (b) pressure at a point in a fluid
- (c) discharge of a fluid
- (d) none of the above

(xiv) If the density of a fluid is constant from point to point in a flow region, it is called

- (a) steady flow

(b) incompressible flow

(c) uniform flow

(d) rotational flow

(xv) Venturimeter is used to measure

- (a) discharge
- (b) average velocity
- (c) velocity at a point
- (d) pressure at a point

(xvi) The ratio of specific heats of a gas at constant pressure and at constant volume is

- (a) always a constant
- (b) always varies with the pressure
- (c) always varies with temperature
- (d) none of the above

(xvii) The sum of internal energy and the product of pressure and volume is called

- (a) entropy
- (b) enthalpy
- (c) heat supplied
- (d) none of the above

**(xviii) The energy associated with molecular motion is called**

- (a) kinetic energy of gas**
- (b) internal energy**
- (c) entropy**
- (d) enthalpy**

**(xix) In terms of thermodynamics, the change of property of a matter**

- (a) depends upon the thermodynamic path followed to reach a state**
- (b) it is fixed by the end states and is independent of path followed**
- (c) it is not fixed by the end states**
- (d) it is not connected with thermodynamic system**

**(xx) Thermal power plants used the cycle known as**

- (a) Otto**
- (b) Carnot**
- (c) Brayton**
- (d) Rankine**

**S'06 : 3 FN : AN 205 (1405)****MECHANICAL SCIENCE***Time : Three hours**Maximum Marks : 100*

*Answer FIVE questions, taking ANY TWO from Group A ,  
ANY TWO from Group B and ALL from Group C.*

*All parts of a question (a, b, etc.) should  
be answered at one place.*

*Answer should be brief and to-the-point and be supplemented  
with neat sketches. Unnecessary long answers may  
result in loss of marks.*

*Any missing data or wrong data may be assumed suitably giving  
proper justification.*

*Figures on the right-hand side margin indicate full marks.*

**Group A**

1. (a) Define and explain the following terms : 3
- (i) Coplanar and non-coplanar forces.
  - (ii) Collinear and concurrent forces.
  - (iii) Parallel and non-parallel forces.
- (b) Four parallel forces of magnitudes 100 N, 150 N, 25 N and 200 N are shown in Fig. 1(b). Determine the magnitude of the resultant and also the distance of the resultant from A. 4

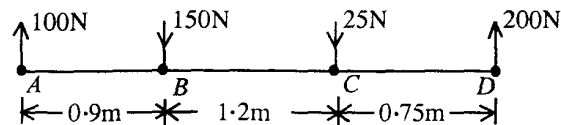

Fig. 1(b)

*( Turn Over )*



- (c) Two spheres each of weight 1000N and of radius 25 cm rest in a horizontal channel of width as shown in Fig. 1(c). Find the reactions on the points of contacts A, B and C.

7

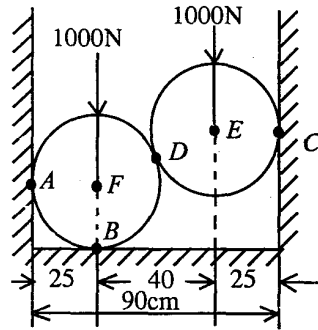

Fig. 1(c)

- (d) Locate the C.G of the area shown in Fig. 1(d) with respect to co-ordinate axis. All dimensions are in mm.

6

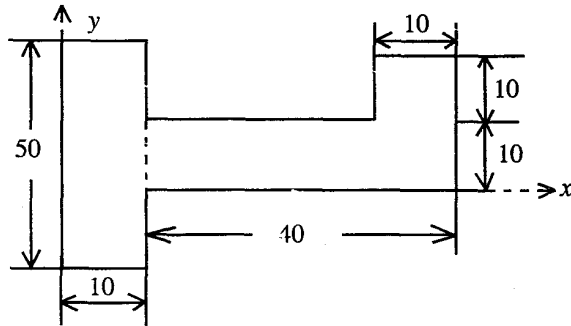

Fig. 1(d)

2. (a) Derive the following equations of motion of a body moving in a straight line with uniform acceleration: 4

(i)  $S = ut + \frac{1}{2} at^2$

(ii)  $V^2 = u^2 + 2aS$

- (b) An object is thrown vertically upward with a velocity of 30m/s. Four seconds later a second object is thrown upward with a velocity of 40 m/s. Determine

(i) the time (after the first object is thrown) when the two objects will meet each other in air

(ii) the height from the earth at which the two objects will meet. 7

- (c) In a mechanism a cross-head moves in a straight guide with simple harmonic motion. At a distance 125 mm and 200 mm from its mean position, it has velocities of 6 m/s and 3 m/s respectively. Find the amplitude, maximum velocities and period of vibration. If the cross-head has a mass of 0.2 kg, calculate the maximum force on it in the direction of motion. 9

3. (a) A circular bar of metal has a diameter  $d_1$  at one end which tapers uniformly to a diameter  $d_2$  at the other end. Find the elongation of the bar under an axial pull  $P$ . Take the length of the bar =  $L$ . 6

- (b) A rigid bar is suspended from three rods and loaded as shown in Fig. 3(b). rod (1) is copper with a cross-sectional area of  $1\text{ cm}^2$  rod (2) is steel with a cross-sectional area of  $1.5\text{ cm}^2$  and rod (3) is of aluminium with a cross-sectional area of  $2\text{ cm}^2$ . Determine the stresses in the rods.

Take  $E_1 = 1 \times 10^7 \text{ N/cm}^2$ ,  $E_2 = 2 \times 10^7 \text{ N/cm}^2$  and  $E_3 = 0.7 \times 10^7 \text{ N/cm}^2$ .

7

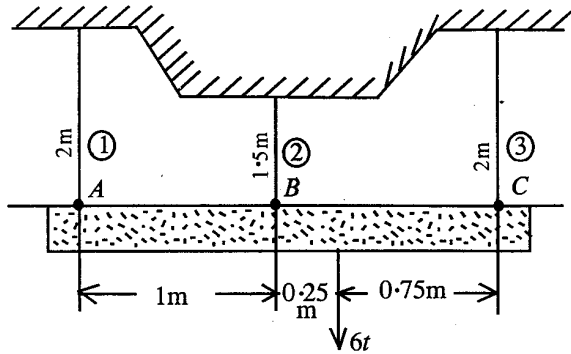

Fig. 3(b)

(c) A hollow cylinder of external diameter 25 cm and internal diameter 12.5 cm and having a length of 50 cm is subjected to an axial load which causes an average compressive stress of  $20\,000 \text{ N/cm}^2$ . The modulus of elasticity of the material is  $2 \times 10^7 \text{ N/cm}^2$ . Poisson's ratio for the material is 0.25. Determine

(i) change in linear dimension

(ii) change in internal volume.

7

1. (a) A thin cylindrical shell of 50 cm diameter, 2 m long and 1 cm thick is filled with a fluid at atmospheric pressure. If an additional 200 cc of fluid is pumped into it, find the internal pressure and hoop stress setup in the material of the cylinder. Take  $E = 2 \times 10^7 \text{ N/cm}^2$  and Poisson's ratio,  $\frac{1}{m} = 0.25$ .

7

(b) Prove  $\frac{\tau}{R} = \frac{T}{J} = \frac{C\theta}{l}$  for a circular shaft from the fundamentals where

$T$  = Torque applied

$J$  = Polar moment of inertia

$C$  = Modulus of rigidity

$l$  = Length of the shaft.

$\tau$  = Shear stress

$R$  = Radius

$\theta$  = Angle of twist

7

(c) Draw the shear force and bending moment diagrams for the cantilever shown in Fig. 4(c).

6

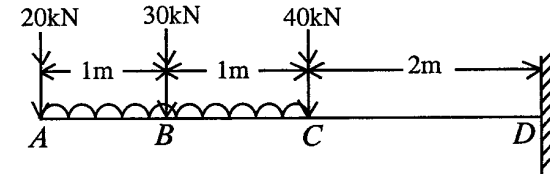

Fig. 4 (c)

**Group B**

5. (a) State and explain Newton's law of viscosity. Explain the importance of viscosity in fluid motion. What is the effect of temperature on viscosity of water and that of air?

4

(b) A circular plate of 3 m diameter is immersed in water in such a way that its greatest and least depth below the free surface are 4 m and 1.5 m respectively. Determine the total pressure on one face of the plate and position of centre of pressure.

8

- (c) If for a two-dimensional potential flow the velocity potential is given by  $\phi = x(2y - 1)$ , determine the velocity at the point  $P(4, 5)$ . Determine also the value of stream function  $\psi$  at the point  $P$ . 8
6. (a) Explain the thermodynamic concept of the following : state, path, process, equilibrium. 6
- (b) A piston-cylinder device initially contains air at 150 kPa and 27°C. At this state the piston is resting on a pair of stops and the enclosed volume is 400 litres. The mass of the piston is such that a 350 kPa pressure is required to move it. The air is now heated until its volume is doubled. Determine the final temp. the work done by the air and the total heat added. Represent the processes in a  $P-V$  diagram. 9
- (c) The internal energy of a system is a function of temperature only and is given by  $U = 25 + 0.25 T$  (kJ) where  $T$  is in °C. When this system executes a certain process the work done per degree temp. change is given by  $\frac{dw}{dT} = 37\sqrt{T}$  N-m. Find the heat transferred when the temp. of the system changes from 100°C to 260°C. 5
7. (a) State and prove Carnot theorems. 6
- (b) State and classical statements of second law of thermodynamics and prove that the violation of one statement will lead to the violation of other statement. 6

- (c) A Carnot heat engine receives heat at 750 K and rejects waste heat to the environment at 300 K. The entire work output of the heat engine is used to drive a Carnot refrigerator which removes heat from the cooled space at -15°C at a rate of 400 kJ/min and rejects it to the same environment at 300 K. Determine (i) the rate of heat supplied to the heat engine and (ii) the total rate of heat rejection to the environment. 8

8. (a) Compare SI engines and CI engines with respect to construction, working and performance. 8
- (b) Two engines are to operate on Otto and Diesel cycle respectively with the following data, Maximum temperature - 1500 K, exhaust temperature - 700 K, Inlet temp. - 300 K, inlet pressure 1 bar. Find out and compare the following for both the cycles :
- (i) Compression ratio
- (ii) Maximum pressure
- (iii) Thermal efficiency. 12

### Group C

9. Choose the most appropriate answer and write only the letter code in the answer book : 1 × 20
- (i) Two forces of equal magnitude  $P$  act at an angle  $\theta$  to each other. Their resultant is equal to
- (a)  $2P \sin \frac{\theta}{2}$
- (b)  $2P \cos \theta / 2$

- (c)  $2P \cos \theta$
- (d)  $P \cos 2\theta$ .
- (ii) A body is allowed to fall from the top of a tower. It falls through half the height in 2 seconds. The total time taken to reach the ground is nearly
- (a) 4.5 sec
- (b) 4 sec
- (c) 3.2 sec
- (d) 2.8 sec.
- (iii) A particle executes simple harmonic motion with an amplitude of 3 cm and time period of 6 seconds. Its maximum velocity will be (cm/s)
- (a)  $\pi/2$
- (b)  $\pi$
- (c)  $2\pi$
- (d)  $3\pi$ .
- (iv) A copper wire of same length but the double the diameter of steel wire is stretched by the same force. If Young's modulus of copper is half that of steel, the elongations in the copper and steel wires would be in the ratio of
- (a) 1 : 2
- (b) 1 : 4
- (c) 1 : 1
- (d) 1 : 8.
- (v) A cantilever beam 8 m long carries a uniformly distributed load of  $w$  N/m run throughout its entire length. If the maximum bending moment is 3200 N-m the rate of loading  $w$  is
- (a) 25 N/m-run
- (b) 50 N/m-run
- (c) 75 N/m-run
- (d) 100 N/m-run.
- (vi) Which of the following beams is likely to have a point of contra flexure ?
- (a) cantilever beam
- (b) simply supported beam
- (c) beam with overhangs
- (d) beam fixed at both ends.
- (vii) A thin cylinder with both ends closed is subjected to internal pressure  $p$ . The longitudinal stress at the surface has been calculated as  $\sigma_0$ . Maximum shear stress at the surface will be equal to
- (a)  $2\sigma_0$
- (b)  $1.5 \sigma_0$

- (c)  $\sigma_0$
- (d)  $0.5 \sigma_0$
- (viii) A right circular cone of 20 cm height weighs 1000 N. A cone of 8 cm height and 64 N weight is removed from the top. The distance of CG of the frustum from the base is approximately
- (a) 2.5 cm
- (b) 3.25 cm
- (c) 4.25 cm
- (d) 6 cm.
- (ix) The moment of inertia about centroidal axis parallel to a side for a cube of mass  $m$  is
- (a)  $\frac{ma^2}{3}$
- (b)  $\frac{ma^2}{6}$
- (c)  $\frac{ma^2}{8}$
- (d)  $\frac{ma^2}{12}$
- (x) A car is traveling at 90 km/hr on a rough road and the coefficient of friction between the road surface and the car tyres is 0.5. At which distance the car will stop when the brakes are jammed suddenly. Take  $g = 10 \text{ m/s}^2$
- (a) 37.8 m
- (b) 45.6 m
- (c) 62.5 m
- (d) 70.2 m.
- (xi) Surface tension is a phenomenon due to
- (a) viscous forces
- (b) cohesion between the liquid molecules
- (c) adhesion between liquid and solid molecules
- (d) adhesion and cohesion both.
- (xii) A stream function for a two-dimensional flow is represented by  $\psi = y^2 - x^2$ . The corresponding velocity potential function for the flow field would be
- (a)  $\phi = 2xy + c$
- (b)  $\phi = 2(x^2 - y^2)$
- (c)  $\phi = 2xy + f(y)$
- (d)  $\phi = 2xy + f(x)$ .
- (xiii) Heat supplied to a system equals the work done in case of a non-flow process carried out
- (a) isochorically
- (b) isobarically
- (c) isothermally
- (d) adiabatically.

**(xx) Which type of engine most cars have ?**

- (a) two stroke cycle engine**
- (b) four stroke cycle engine**
- (c) rotary Wankel engine**
- (d) free piston engine.**

**S'07 : 3 FN : AN 205 (1405)**

**MECHANICAL SCIENCE**

*Time : Three hours*

*Maximum Marks : 100*

*Answer FIVE questions, taking ANY TWO from Group A ,  
ANY TWO from Group B and ALL from Group C .*

*All parts of a question ( a, b, etc. ) should  
be answered at one place.*

*Answer should be brief and to-the-point and be supplemented  
with neat sketches. Unnecessary long answers may  
result in loss of marks.*

*Any missing or wrong data may be assumed suitably giving  
proper justification.*

*Figures on the right-hand side margin indicate full marks .*

**Group A**

1. (a) Weights  $P$  and  $Q$  have been suspended in a vertical plane by strings 1, 2, 3 arranged as shown in Fig. 1. Find the tensions induced in each string, if  $P = 2250 \text{ N}$  and  $Q = 4500 \text{ N}$ .

6

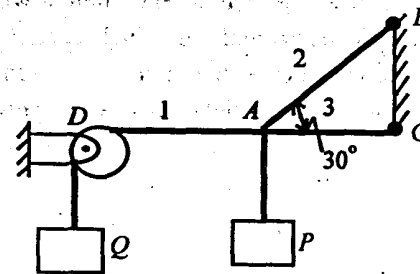

Fig. 1

(b) A load of 2500 N is to be raised by a screw jack with mean diameter of 75 mm and pitch of 12 mm. Find the efficiency of the screw jack, if the coefficient of friction between the screw and nut is 0.075. 7

(c) A rectangular lamina, having width  $b$  and depth  $d$ , is resting on a horizontal surface with its width parallel to the horizontal line. Find the area moment of inertia of the rectangle about an axis parallel to its width and passing through the c. g. of the rectangle. 7

2. (a) State Newton's laws of motion. 4

(b) A particle initially at rest is submitted to the action of a force  $F = kt$ ; where  $t$  is the time and  $k$ , a constant. Prove that the ratio of displacement  $x$  at any time to the velocity of the particle at that time is a linear function of time. 8

(c) A weight of 31.5 N produces a static elongation of 3.048 cm in a given spring. Determine the period of vibration of a body having weight 45 N suspended from the same spring. 8

3. (a) Two vertical wires are suspended from a ceiling at a distance of 500 mm apart. Their upper ends are firmly secured at the ceiling and their lower ends support a rigid horizontal bar which carries a load  $W$ . The left wire has a diameter of 1.6 mm and is made of copper and the right wire has a diameter of 0.9 mm and is made of steel. Both wires initially are 4.5 m long. Determine the position of the line of action of  $W$ , if the rigid bar is to remain horizontal after loading. Take:

$$E_s = 2.1 \times 10^5 \text{ N/mm}^2 \text{ and } E_c = 1.3 \times 10^5 \text{ N/mm}^2.$$

(b) Figure. 2 shows a loaded rod of steel in equilibrium. It is supported on a stop at C. Find the change in length of the rod. Modulus of elasticity of steel is  $2 \times 10^5 \text{ N/mm}^2$ . 6

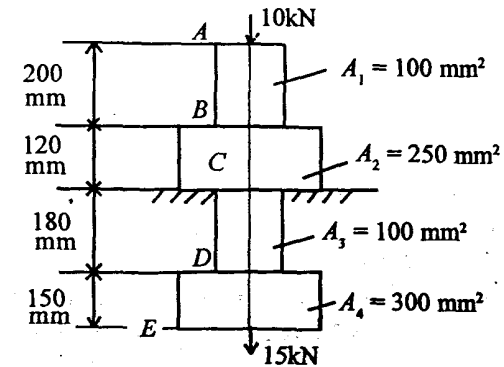

Fig. 2

(c) A bar of 30 mm diameter is subjected to a pull of 60 kN. The measured extension on a gauge length of 200 mm is 0.9 mm and the change in diameter is 0.0039 mm. Calculate the Poisson's ratio and the value of the Young's modulus and the modulus of rigidity. 7

4. (a) A cantilever of length  $l$  is carrying a uniformly distributed load of  $w$  per unit length over the whole length. Establish the equation for the shear force and the bending moment for the beam at any section. Draw the shear force and bending moment diagrams. 10

(b) A cantilever of length  $l$  is carrying a concentrated load  $W$  at the free end. Find an expression for the deflection of the cantilever at the free end. 10



---

AMIE(I) STUDY CIRCLE, SECOND FLOOR, SULTAN TOWER, ROORKEE - 247667 (UTTARANCHAL) EMAIL: [pcourses@hotmail.com](mailto:pcourses@hotmail.com) Ph: (01332) 266328, 9412903929, 9897394020

### Group B

5. (a) Explain what is meant by surface tension on liquid droplet. 4
- (b) A sliding gate, 2 m wide and 1 m high, lies in a vertical plane and can be moved vertically against two side guides. The coefficient of friction between the gate and the guides is 0.15. If the gate weighs 2 kN, find the vertical force required to raise the gate, if its upper edge is at a depth of 6 m from the free surface of water. 8
- (c) What is a manometer? What are the classifications of manometers? Explain the principle of operation of any *one* type of manometer. 8
6. (a) Explain the thermodynamic concept of the following terms: thermodynamic system, property of a system, path function, and point function of a system. 6
- (b) Pressure vessels of  $10\text{m}^3$  are used for storing oxygen and nitrogen at a pressure of 15 technical atmosphere and a temperature of  $40^\circ\text{C}$ . Determine the mass of each gas that can be stored in the tank. Take standard properties of oxygen and nitrogen gases. 8
- (c) A gas is compressed in a cylinder by a moveable piston to a volume one half of its original volume. During this process, it was found that 80 kcal of heat was left the gas, and internal energy of the gas remained the same. Considering the gas as the system, calculate the work done. 6
7. (a) A heat engine is supplied with 278 kcal/s of heat at constant fixed temperature of  $283^\circ\text{C}$  and the heat rejection takes place at  $5^\circ\text{C}$ . The following results were reported:
- (i) 208 kcal/s heat rejected;
- (ii) 139 kcal/s heat rejected; and
- (iii) 70 kcal/s heat rejected.
- Classify which of the results report a reversible cycle or irreversible cycle or impossible cycle? Apply Clausius inequality to justify your comments. 7
- (b) State and explain what is meant by perpetual motion machine of the second kind. 5
- (c)  $4.0\text{m}^3$  of air at a pressure of  $50\text{N/cm}^2$  and a temperature of  $27^\circ\text{C}$  expand reversibly in a cylinder to a pressure of  $10\text{N/cm}^2$ . The final volume is  $20\text{m}^3$ . Assume constant specific heat for this process and calculate the
- (i) heat transferred during this process; and 4
- (ii) change of entropy during this process. 4
8. (a) Describe the working principle of a spark ignition engine with the help of a P-V diagram. 10
- (b) An ideal Otto engine working on the air standard has a temperature and pressure at the beginning of  $25^\circ\text{C}$  and  $10\text{N/cm}^2$ , respectively, and a thermal efficiency of 48%. Determine the pressure and temperature at the end of the compression. 10

**Group C**

9. Answer the following in brief: 2 × 10

- (i) For a statically determinate two-dimensional structure, how many unknown parameters can be found out ?
- (ii) What is angle of friction ?
- (iii) Define mass moment of inertia of a rigid body.
- (iv) What is viscosity of a fluid ?
- (v) What are the types of stresses developed in the membrane of a thin walled pressure vessel ?
- (vi) Draw the stress-strain diagram of a mild steel material and show the salient points on the diagram.
- (vii) In case of torsional load on a member with circular section, state whether the maximum shear stress occurs at the centre of the section or at the outer periphery of the section ? Justify your statement.
- (viii) Write the mathematical expression of the First Law of Thermodynamics in terms of change in internal energy, heat supplied, and the work done during any change in state of a system.
- (ix) For a reversible adiabatic process, prove that there is no change in entropy.
- (x) On what factors does the thermal efficiency of Otto cycle depend ?

**W'07 : 3 FN : AN 205 (1405)****MECHANICAL SCIENCE***Time : Three hours**Maximum Marks : 100*

*Answer FIVE questions, taking ANY TWO from Group A ,  
ANY TWO from Group B and ALL from Group C .*

*All parts of a question ( a, b, etc. ) should  
be answered at one place.*

*Answer should be brief and to-the-point and be supplemented  
with neat sketches. Unnecessary long answers may  
result in loss of marks.*

*Any missing or wrong data may be assumed suitably giving  
proper justification.*

*Figures on the right-hand side margin indicate full marks .*

**Group A**

1. (a) Two bars  $AC$  and  $BC$  are hinged together at  $C$ . Their other ends are hinged to a vertical wall at  $A$  and  $B$  as shown in Fig. 1 (a). Find the axial forces in the bar. 6

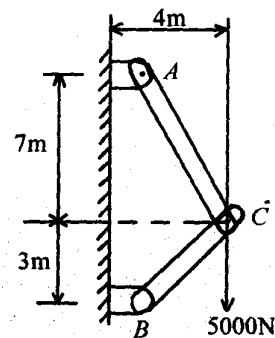
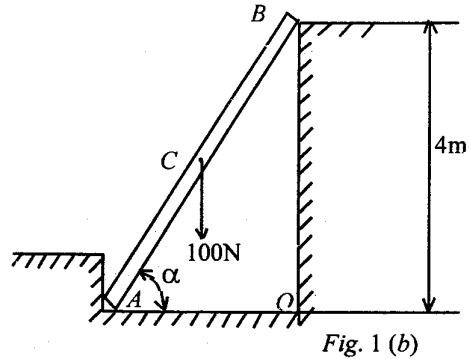

Fig. 1 (a)

- (b) A man weighing 100 N stands on the middle point of a ladder  $AB$  whose weight can be neglected [Fig. 1 (b)]. Assuming that the floor and walls are perfectly smooth and that slipping is prevented by a stop at  $A$ , find the reactions at  $A$  and  $B$ . Given  $\alpha = 60^\circ$ .

6



- (c) Two planes  $AC$  and  $BC$  inclined at  $60^\circ$  and  $30^\circ$  to the horizontal meet at  $C$ . A load of 1000 N rests on the inclined plane  $BC$  and is tied by a rope passing over a pulley to a block weighing  $W$  Newtons and resting on the plane  $AC$  as shown in Fig. 1 (c). If the coefficient of friction between the load and the plane  $BC$  is 0.28 and that between the block and the plane  $AC$  is 0.20, find the least and the greatest value of  $W$  for the equilibrium of the system.

8

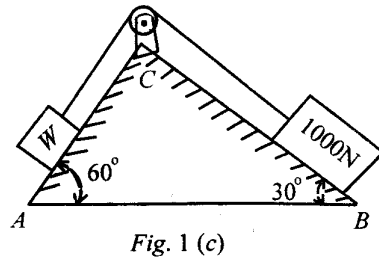

2. (a) A particle moving along a straight line has an acceleration  $a = \sqrt{V}$ . At time  $t = 2$  s, its displacement is 42.67 m and velocity is 16 m/s. Find the displacement, velocity and acceleration at  $t = 3$  s.
- (b) A particle of weight  $W$  attached to a fixed point  $O$  by a string  $OA$  of length  $l$  whirls in a horizontal circular path of radius  $r$  with uniform speed  $V$  so that the string generates a height  $h$  as shown in Fig. 2 (b). Find the relation between  $V$ ,  $r$  and  $h$  and the tensile force  $T$  in the string.

7

7

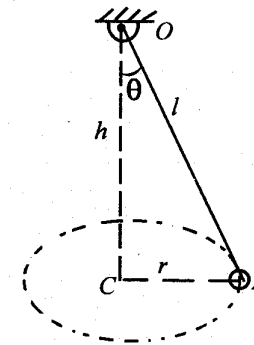

Fig. 2 (b)

- (c) A screw jack has a thread of 12 mm pitch. What effort will be applied at the end of a handle of 450 mm to lift a load 2.5 kN, if the corresponding efficiency is 50%?
3. (a) A steel rod, 4 m long and 20 mm diameter, is subjected to an axial tensile load of 45 kN. Find the change in length, diameter and volume of the rod. Take  $E_s = 2 \times 10^5 \text{ N/mm}^2$  and Poisson's ratio =  $1/4$ .

6

7

(b) Define Hooke's law. Draw a stress-strain diagram for a mild steel rod under a tensile test. Explain all the salient features. 6

(c) What do you mean by principal stresses? What is Mohr's circle? What is its significance? 7

4. (a) A solid circular shaft, 100 mm in diameter, is subjected to a torque of 12 kN-m. Determine the maximum shear stress developed and the twist over a length of 2 m. Assume that  $G = 0.8 \times 10^5 \text{ N/mm}^2$ . 5

(b) Determine the moment of inertia for a rectangle of base  $b$  and depth  $h$  with respect to (i) a centroidal axis parallel to the base; and (ii) an axis coinciding with the base. 5

(c) Write the shear and moment equations for the beam loaded as shown in Fig. 4(c) and sketch the shear force and bending moment diagrams. 10

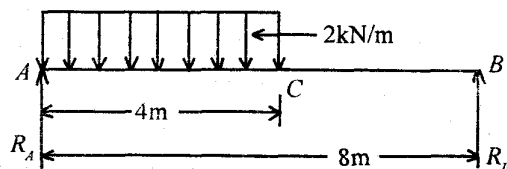

Fig. 4 (c)

### Group B

5. (a) A 15 cm diameter vertical cylinder rotates concentrically inside another cylinder of diameter 15.10 cm. Both cylinders are 25 cm high. The space between the cylinders is filled with a liquid whose viscosity is unknown. If a torque of 12 Nm is required to rotate the inner cylinder at 100 rpm, determine the viscosity of the fluid. 6

(b) A circular plate of 3 m diameter is immersed in water in such a way that its greatest and least depth below the free surface are 4 m and 1.5 m, respectively. Determine the total pressure on one face of the plate and position of the centre of pressure. 7

(c) A venturimeter, with an inlet diameter of 30 cm and a throat diameter of 15 cm, is provided in a vertical pipeline carrying oil of specific gravity 0.9, the flow being upwards. The difference in elevation of the throat section and entrance section of the venturimeter is 30 cm. The differential U-tube mercury manometer shows a gauge deflection of 25 cm. Calculate the

(i) discharge of oil, and

(ii) pressure difference between the entrance section and the throat section. Take the coefficient of meter as 0.98 and specific gravity of mercury as 13.6. 7

6. (a) Write the thermodynamics definitions of work and heat. What are the common features of both heat and work? 5

(b) A  $0.2 \text{ m}^3$  of air at 4 bar and  $130^\circ\text{C}$  is contained in a system. A reversible adiabatic expansion takes place until the pressure falls to 1.02 bar. The gas is then heated at constant pressure until the enthalpy increases by 72.5 kJ. Determine the (i) network done; and (ii) index of expansion if the above processes are replaced by a single reversible polytropic process giving the same work between the same initial and final states. Take  $C_p = 1.005 \text{ kJ/kg}^\circ\text{K}$  and  $C_v = 0.718 \text{ kJ/kg}^\circ\text{K}$ .

8

(c) Air flows steadily at the rate of 0.5 kg/s through an air compressor. It enters the compressor at 6 m/s with a pressure of 1 bar and a volume of  $0.85 \text{ m}^3/\text{kg}$  and leaves at 5 m/s with a pressure of 7 bar and a volume of  $0.16 \text{ m}^3/\text{kg}$ . The internal energy of the air leaving is 90 kJ/kg greater than that of the air entering. Cooling water in the jacket surrounding the cylinder absorbs heat from the air at the rate of 60 kJ/s. Calculate the (i) power required to drive the compressor; and (ii) inlet and outlet pipe cross-sectional areas.

7

(a) State the first law of thermodynamics for a closed system undergoing a cycle and prove that internal energy is a property of the system.

6

(b) Sketch the Carnot cycle on  $P$ - $V$  and  $T$ - $S$  planes and derive an expression for its thermal efficiency in terms of source and sink temperature.

6

(c) A reversible heat engine operates between two reservoirs at temperatures of  $600^\circ\text{C}$  and  $40^\circ\text{C}$ . The engine drives a reversible refrigerator which operates between reservoirs at temperatures of  $40^\circ\text{C}$  and  $-20^\circ\text{C}$ . The heat transfer to the heat engine is 2000 kJ and the network output of combined engine refrigerator plant is 360 kJ. Calculate the (i) heat transfer to the refrigerator; and (ii) net heat transfer to the reservoir at  $40^\circ\text{C}$ .

8

8. (a) Derive an expression for thermal efficiency of Otto cycle in terms of compression ratio and ratio of specific heats.

6

(b) Prove that violation of Clausius statement means violation of Kelvin-Planck statement of second law of thermodynamics.

6

(c) In an air standard diesel cycle, the compression ratio is 16, and at the beginning of isentropic compression, the temperature is  $15^\circ\text{C}$  and the pressure is 0.1 MPa. Heat is added until the temperature at the end of constant pressure process is  $1480^\circ\text{C}$ . Calculate the (i) cut-off ratio, (ii) heat supplied per kg of air, (iii) cycle efficiency, (iv) mean effective pressure. Assume  $\gamma = 1.4$ ,  $C_p = 1.005 \text{ kJ/kg}^\circ\text{K}$ ,  $C_v = 0.718 \text{ kJ/kg}^\circ\text{K}$ .

8

### Group C

9. Choose the *correct* answer and write only the letter code in the answer book without repeating the text of the question: 1 x 20

(i) A couple can be balanced by

(a) a force

- (b) a moment
- (c) a torque
- (d) an equal and opposite couple.
- (ii) If two forces of magnitude  $P$  act with an included angle  $\theta$ , then the resultant will be
- (a)  $2P \cos(\theta/2)$
- (b)  $2P \sin \theta$
- (c)  $2P \cos \theta$
- (d)  $P \cos 2\theta$ .
- (iii) The centre of gravity of a hemisphere of radius  $r$  from its base measured along vertical radius is
- (a)  $4r/3$
- (b)  $3r/2$
- (c)  $3r/8$
- (d)  $4r/7$ .
- (iv) In a simple harmonic motion, the time period of oscillation is given by
- (a)  $T = 2\pi/\omega$
- (b)  $T = 2\pi\omega$
- (c)  $T = 2\pi/\omega^2$
- (d)  $T = 2\omega/\pi$ .
- (v) According to kinetic theory of heat,
- (a) temperature should raise during boiling
- (b) temperature should fall during freezing
- (c) at low temperature all bodies are in solid state
- (d) at absolute zero there is absolutely no vibration of molecules.
- (vi) Work output of theoretical Otto cycle
- (a) increases with increase in compression ratio
- (b) increases with increase in pressure ratio
- (c) increases with increase in index of the process
- (d) follows all the above.
- (vii) A perfect gas
- (a) does not obey the law  $PV = RT$
- (b) obeys the law  $PV = RT$  and has constant specific heat
- (c) obeys the law  $PV = RT$  but has variable specific heat
- (d) None of the above.
- (viii) Joule's law states that the specific internal energy of a gas depends only on the
- (a) pressure of the gas



- (b) volume of the gas
- (c) temperature of the gas
- (d) None of the above.
- (ix) For a reversible adiabatic process, the change in entropy is
- (a) zero
- (b) minimum
- (c) maximum
- (d) unity.
- (x) Work done in a free expansion process is
- (a) zero
- (b) minimum
- (c) maximum
- (d) negative.
- (xi) In isothermal process,
- (a) volume remains constant
- (b) temperature increases gradually
- (c) change in internal energy is zero
- (d) pressure remains constant.
- (xii) Which of the following is the extensive property of a thermodynamic system ?
- (a) Pressure
- (b) Volume
- (c) Temperature
- (d) Density.
- (xiii) Viscosity of gases
- (a) decrease with the increase of temperature
- (b) increase with the increase of temperature
- (c) remain same with the increase of temperature
- (d) None of the above.
- (xiv) For unstable equilibrium of submerged body,
- (a) centre of buoyancy is below the centre of gravity
- (b) centre of buoyancy is above the centre of gravity
- (c) centre of buoyancy coincides with the centre of gravity
- (d) None of the above.
- (xv) Which of the following device is used to measure the velocity of a fluid in a pipe ?
- (a) Venturimeter
- (b) Pitot tube

- (c) Orifice meter
- (d) Rectangular notch.
- (xvi) The centre of pressure of a plane submerged surface
- (a) should always coincide with the centroid of the surface
- (b) should always be above the centroid of the surface
- (c) should always be below the centroid of the surface
- (d) None of the above.
- (xvii) The radius of Mohr's circle for two unlike principal stresses of magnitude  $p$  is
- (a)  $p$
- (b)  $p/2$
- (c)  $p/4$
- (d) None of the above.
- (xviii) Maximum bending moment occurs when
- (a) shear force is maximum
- (b) shear force is minimum
- (c) shear force changes sign
- (d) deflection is zero.

(xix) The maximum shear stress in a solid circular shaft due to torsion  $T$  can be expressed as

(a)  $\tau_{\max} = 16 T / \pi d^3$

(b)  $\tau_{\max} = 16 \pi / T d^3$

(c)  $\tau_{\max} = 16 d^3 / \pi T^3$

(d)  $\tau_{\max} = \pi T / 16 d^3$ .

(xx) Thin cylindrical vessel of diameter 100 mm, wall thickness 2.5 mm is subjected to an internal water pressure of  $1.5 \text{ N/mm}^2$ . The maximum stress developed in a cylinder wall is

(a)  $15 \text{ N/mm}^2$

(b)  $30 \text{ N/mm}^2$

(c)  $60 \text{ N/mm}^2$

(d)  $120 \text{ N/mm}^2$ .

**S'08 : 3 FN : AN 205 (1405)****MECHANICAL SCIENCE***Time : Three hours**Maximum Marks : 100*

*Answer FIVE questions, taking ANY TWO from Group A,  
ANY TWO from Group B and ALL from Group C.*

*All parts of a question ( a, b, etc. ) should  
be answered at one place.*

*Answer should be brief and to-the-point and be supplemented  
with neat sketches. Unnecessary long answers may  
result in loss of marks.*

*Any missing or wrong data may be assumed suitably giving  
proper justification.*

*Figures on the right-hand side margin indicate full marks .*

**Group A**

1. (a) State the laws of Coulomb friction. 3
- (b) A 100N force acts as shown in Fig. 1 on a 300N block placed on an inclined plane. The coefficients of friction between the block and the plane are  $\mu_s = 0.25$  and  $\mu_k = 0.20$ . Determine whether the block is in equilibrium, and find the value of the friction force. 7

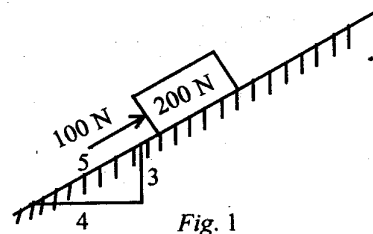

Fig. 1

- (c) State the principle of virtual work. 4
- (d) A screw jack has a double thread of mean diameter 0.05 m. The pitch is 0.005 m. If a force  $F$  of 200 N is applied to the device, by a lever of length 0.2 m, what load  $W$  can be raised? With this load on the device, what will happen if the applied force  $F$  is released? Take  $\mu_s = 0.3$  for all surfaces of contact. 6

2. (a) A projectile is fired with an angle of projection  $\alpha$ . Find the expression for the trajectory of the projectile. Also, find the maximum range and maximum height of the flight of the projectile. 6

(b) Two billiard balls of same size and mass collide with the velocities of approach 1.6 m/s and 3.5 m/s, respectively. The angle between their directions of motion is  $45^\circ$ . For a coefficient of restitution of 0.9, what are the final velocities of the balls immediately after the impact? What is the loss in kinetic energy? 8

(c) A vibrating system is shown in Fig. 2. The block is pulled 40 mm down from its equilibrium position and released. For springs,  $k_1 = 4 \text{ kN/m}$  and  $k_2 = 6 \text{ kN/m}$ .

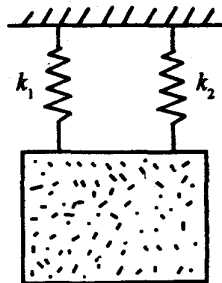

Fig. 2

Determine the period of vibration, the minimum velocity of block, and the maximum acceleration of block. The mass of the block is 50 kg. 6

3. (a) Describe the experimental procedure of a tensile test on a round steel bar. Draw the stress-strain curve and show the salient points on the curve. How do you determine Young's modulus ( $E$ ) and Poisson's ratio ( $\nu$ ) from this test? 6

(b) A state of stress at a given point in a loaded member is shown in Fig. 3.

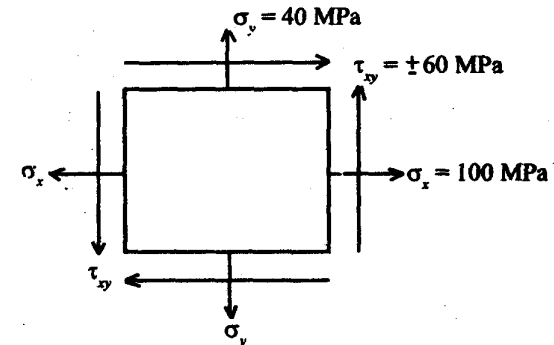

Fig. 3

Find the principal stresses. What is the value of maximum shear stress? 6

(c) The air vessel of a torpedo has an external diameter of 53 cm, 1 cm thick and has a length of 183 cm. Determine the increase in its external diameter and length when it is charged to 10.5 MPa of internal pressure. Given  $E = 210 \text{ GPa}$ ,  $\nu = 0.3$ . 8

4. (a) Draw the shear force and bending moment diagrams for simply-supported beam and loaded as shown in Fig. 4. 8

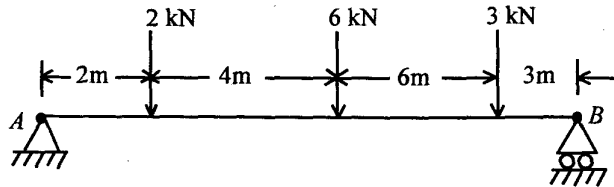

Fig. 4

- (b) A simply-supported prismatic beam  $AB$  carries a uniformly distributed load  $w$  per unit length over the entire span of the beam. Derive the equation of the elastic deflection curve for the beam. Also, find the maximum deflection of the beam. 6

- (c) A hollow shaft has inner and outer diameters of 100 mm and 150 mm, respectively. The allowable shearing stress is 82 MPa. Determine the maximum torque that can be transmitted. 6

### Group B

5. (a) (i) Define viscosity of fluids.  
 (ii) Explain Newton's law of viscosity. Differentiate between Newtonian and non-Newtonian fluids.  
 (iii) Describe an experiment to measure viscosity of fluids. 4

- (b) A rectangular plate,  $1.2\text{ m} \times 1.8\text{ m}$  is submerged in water and makes an angle of  $30^\circ$  with the horizontal, the  $1.2\text{ m}$  side being horizontal. Calculate the magnitude of the net force on one face and the position of centre of pressure when the top edge of the plane is (i) at the water surface, and (ii) 30 m below the water surface. 8

- (c) A wooden platform, 10 m long, 6 m wide and 3 m deep, floats in water. A cylindrical metallic billet of 1 m in diameter has been placed symmetrically on the platform. Estimate the weight of the billet so that the water surface flushes with the platform and calculate the metacentric height. Take  $\rho$  for wood as  $650\text{ kg/m}^3$ . 8

6. (a) Explain conservation of energy and the first law of thermodynamics. 5

- (b) In a certain steam plant, the turbine develops 1000 kW. The heat supplied to the steam in the boiler is 2800 kJ/kg, the heat rejected by the steam to cooling water in the condenser is 2100 kJ/kg and the feed pump work required to pump the condensate back into the boiler is 5 kW. Calculate the steam flow rate. 5

- (c) Define the specific heats at constant volume and constant pressure. Derive the relationship between two specific heat capacities. 5

- (d) What is a throttling device? Show that the enthalpy of the fluid before throttling is equal to the enthalpy of the fluid after throttling. 5

7. (a) What is second law of thermodynamics? Give two different types of statements of this law. Explain this through examples of forward and reversed heat engines. 8
- (b) Explain entropy and irreversibility. 4
- (c) Describe with  $T-s$  and  $p-v$  diagrams, the Carnot cycle for a perfect gas. 4
- (d) A hot reservoir at  $800^{\circ}\text{C}$  and a cold reservoir at  $15^{\circ}\text{C}$  are available. Calculate the ideal thermal efficiency. 4
8. (a) In respect to ideal heat engine cycles, describe SI and CI engine cycles. Explain the methods of calculation of thermal efficiencies in each case. 4
- (b) Compare the compression ratios of SI and CI engines. 2
- (c) With the help of  $p-v$  and  $T-s$  diagrams, show that for the same maximum pressure and temperature of the cycles and the same heat rejection,
- $$\eta_{\text{diesel cycle}} > \eta_{\text{Otto cycle}}$$
- 4
- (d) In an air standard diesel cycle, the compression ratio is 16, and at the beginning of the isentropic compression, the temperature is  $15^{\circ}\text{C}$  and the pressure is  $0.1\text{ MPa}$ . Heat is added until the temperature at the end of the constant pressure process is  $1480^{\circ}\text{C}$ . Calculate the (i) cut-off ratio, (ii) heat supplied per kg of air, (iii) cycle efficiency, and (iv) mean effective pressure. 10

S'08:3FN: AN 205 (1405) ( 6 )

(Continued)

**Group C**

9. Choose the *correct* answer for the following: 1 x 20
- (i) The necessary coefficient of friction between tires and roadway to enable a four wheel drive motor car to climb an uphill of 30% grade is
- (a)  $\mu \geq 0.3$
- (b)  $\mu \leq 0.3$
- (c)  $\mu \geq 0.6$
- (d)  $\mu \geq 0.15$ .
- (ii) The centroid of the shaded area between two circles of radii 2 cm and 1 cm shown has the value of  $x$ -coordinate as

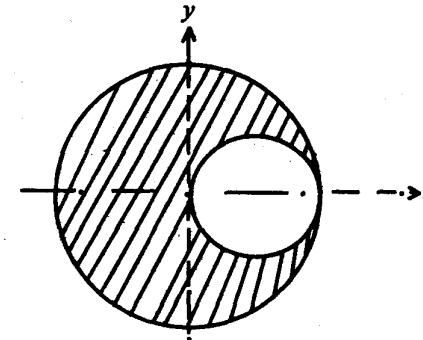

(a)  $-\frac{1}{10}\text{ cm}$

S'08:3FN: AN 205 (1405)

( 7 )

( Turn Over )

(b)  $-\frac{1}{8}$  cm

(c)  $-\frac{1}{4}$  cm

(d)  $-\frac{1}{3}$  cm.

(iii) The force in bar BC of the truss shown is

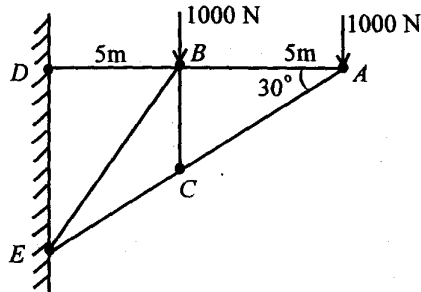

(a) 1000 N compression

(b) 1000 N tension

(c) 500 N compression

(d) 0 N.

(iv) The rectilinear motion of a particle is given by

$$x = x_0 (2e^{-kt} - e^{-2kt})$$

in which  $x_0$  is the initial displacement and  $k$ , a constant. The maximum velocity attained by the particle is

(a)  $kx_0$

(b)  $-kx_0$

(c)  $\frac{1}{2}kx_0$

(d)  $-\frac{1}{2}kx_0$ .

(v) A ball of mass 1 kg moving with a velocity of 2 m/s collides directly on a stationary ball of mass 2 kg and comes to rest after impact. The velocity of the second ball after impact will be

(a) 0

(b) 0.5 m/s

(c) 1 m/s

(d) 2 m/s.

(vi) In a thick cylinder subjected to internal pressure, the variation of the circumferential hoop stress across the thickness is

(a) constant

(b) linear

(c) parabolic

(d) cubic.

(vii) A shaft of diameter  $d$  transmits power  $P$  kW. Another shaft of same material and same length has diameter  $2d$ . The power the second shaft can transmit is

(a)  $P$  kW

- (b)  $2P$  kW  
 (c)  $4P$  kW  
 (d)  $8P$  kW.

(viii) A cantilever of flexural rigidity  $EI$  and length  $L$  is loaded by a u.d.l. of  $w$  over the entire length. The maximum deflection is

- (a)  $WL^4 / 8 EI$   
 (b)  $WL^4 / 12 EI$   
 (c)  $WL^4 / 16 EI$   
 (d)  $WL^4 / 24 EI$ .

(ix) The relation between Young's modulus  $E$ , shear modulus  $G$  and Poisson's ratio  $\nu$  is

- (a)  $E = 2G(1 - \nu)$   
 (b)  $E = 2G(1 + \nu)$   
 (c)  $E = 3G(1 + 2\nu)$   
 (d)  $E = 3G(1 - 2\nu)$ .

(x) At a point the state of stress is given by

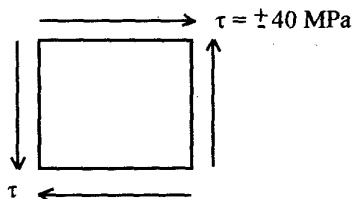

18:3FN: AN205 (1405) ( 10 )

(Continued)

The principal stresses are

- (a)  $\sigma_1 = 40 \text{ MPa}$ ,  $\sigma_2 = -40 \text{ MPa}$   
 (b)  $\sigma_1 = 0$ ,  $\sigma_2 = 0$   
 (c)  $\sigma_1 = 80 \text{ MPa}$ ,  $\sigma_2 = -80 \text{ MPa}$   
 (d)  $\sigma_1 = 40 \text{ MPa}$ ,  $\sigma_2 = 40 \text{ MPa}$ .

(xi) Falling drops of water becomes spherical due to

- (a) adhesion  
 (b) cohesion  
 (c) surface tension  
 (d) viscosity.

(xii) Shock effect in the nozzle generally occurs in

- (a) converging section  
 (b) diverging section  
 (c) throat  
 (d) exit.

(xiii) The thermodynamic cycle used in petrol engine is

- (a) Carnot  
 (b) diesel  
 (c) Brayton  
 (d) Otto.

S'08: 3FN: AN205 (1405) ( 11 )

(Turn Over)



(xiv)  $pV^n = \text{constant}$  with  $n = 1$ . The process is

- (a) constant volume
- (b) constant pressure
- (c) adiabatic
- (d) isothermal.

(xv) During a thermodynamic process, the entropy of the isolated system increases, the process is

- (a) adiabatic
- (b) isothermal
- (c) reversible
- (d) irreversible.

(xvi) Second law of thermodynamics defines

- (a) heat
- (b) temperature
- (c) enthalpy
- (d) entropy.

(xvii) A perfect heat engine works on the Carnot cycle between  $1000^\circ\text{C}$  and  $200^\circ\text{C}$ . The efficiency of the engine is

- (a) 80%

(b) 60%

(c) 42.8%

(d) 68.2%.

(xviii) Ignition quality of diesel fuel is expressed by

- (a) octane number
- (b) cetane number
- (c) calorific value
- (d) carbon percentage.

(xix) Cavitation is caused by

- (a) high velocity
- (b) low velocity
- (c) high pressure
- (d) low pressure.

(xx) The centre of pressure of a vertical equilateral triangular plate with its base parallel and on the surface of the liquid is, where  $a$  = length of each side,

- (a)  $a$
- (b)  $3a/4$
- (c)  $a/2$
- (d)  $2a/3$ .

**MECHANICAL SCIENCE***Time : Three hours**Maximum Marks : 100*

*Answer FIVE questions, taking ANY TWO from Group A,  
ANY TWO from Group B and ALL from Group C.*

*All parts of a question (a, b, etc.) should  
be answered at one place.*

*Answer should be brief and to-the-point and be supplemented  
with neat sketches. Unnecessary long answer may  
result in loss of marks.*

*Any missing or wrong data may be assumed suitably giving  
proper justification.*

*Figures on the right-hand side margin indicate full marks.*

**Group A**

1. (a) Define Hooke's law. Draw the  $\sigma - \epsilon$  diagram for mild steel and indicate its speciality. 3 + 3
- (b) What is modulus of rigidity of a material? What do you mean by Poisson's effect? 2 + 2
- (c) The state of stress at a point of a body is given by:  
 $\sigma_x = 100 \text{ MPa}$ ,  $\sigma_y = -50 \text{ MPa}$  and  $\tau_{xy} = 75 \text{ MPa}$ .

Draw the Mohr's circle for the stress system and find the principal stresses with their orientations. 10

(a) A specimen of rectangular cross-section, 25 mm × 100 mm, has a length 3000 mm. The modulus of elasticity and Poisson's ratio of the material of the specimen is 180 GPa and 0.33, respectively. If an axial load of 500 kN is applied to that bar, find the final length and cross-section. 8

(b) Derive the expressions for the longitudinal stress and tangential stress developed in a thin walled cylinder in terms of internal diameter, internal pressure and shell thickness. Mention the assumptions used for the derivation. 6

(c) Two bodies are connected by a string as shown in Fig. 1. Assuming the coefficient of friction 0.25 and the pulley is smooth, find the minimum value of  $F$  to initiate motion. 6

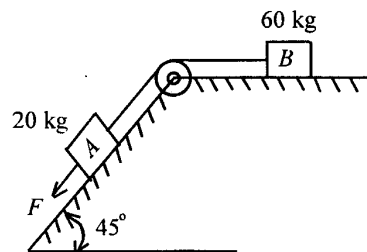

Fig. 1

3. (a) Determine the moment of inertia of the composite figure about an axis through its centre of gravity and parallel to the base, ( $I_{xx}$  and  $I_{yy}$ ) [Fig. 2]. 8

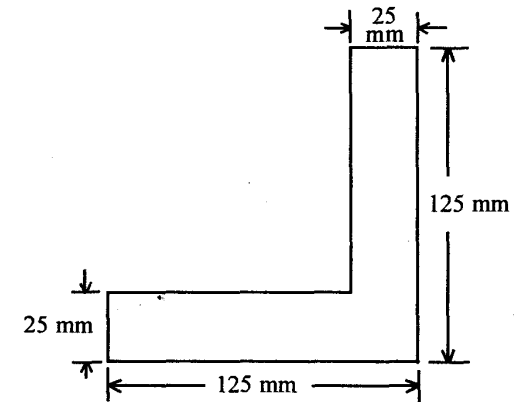

Fig. 2

(b) Draw the bending moment and shear force diagram of the simple-supported beam shown in Fig. 3. 8

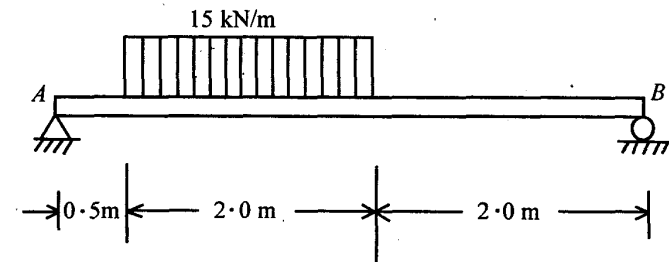

Fig. 3

(c) Define, with suitable examples, the static and kinetic coefficients of friction. 2 + 2

4. (a) What is simple harmonic motion? Write the equation of motion of a undamped spring-mass system. 2 + 2
- (b) A particle moves with rectilinear motion and its speed rises from 0 to 12 m/s in 4 s and then drops to 0 in 2 s. Plot the velocity-time curve and find 8
- (i) acceleration in first 4 s and that in last 2 s;
- (ii) distance travelled in 6 s; and
- (iii) average velocity.
- (c) A solid circular shaft is required to transmit 200 kW with rotation of 1.5 rev/s. If the allowable shearing stress is 42 MPa for the shaft material, find the required shaft diameter. 8

### Group B

5. (a) Sketch the cycle for a petrol engine in  $P-V$  and  $T-\phi$  plane. Name the cycle. 4
- (b) Show that the efficiency of this cycle increases with the increase of compression ratio. 6
- (c) Draw a valve timing diagram of an SI engine and indicate the salient points. 6
- (d) Draw the basic sketch of a carburettor and explain its working. 4
6. (a) State and explain the second law of thermodynamics with the help of an example of a heat engine. 4

- (b) A piston cylinder mechanism contains 2 kg of perfect gas. The gas expands reversibly and isothermally from a pressure of 10 bar and temperature of 327°C to a pressure of 1.8 bar. Calculate the (i) work transfer; (ii) heat transfer, and (iii) change in specific enthalpy of the gas.  
Given:  $R = 0.3 \text{ kJ/kgK}$  and  $\gamma = 1.4$ . 10
- (c) Define and explain entropy. Draw a suitable air standard cycle in  $P-V$  and  $T-\phi$  plane to identify isentropic process. 6
7. (a) Define dynamic viscosity and kinematic viscosity. What are the units for these? 6
- (b) Describe, with figure, an instrument to measure the viscosity of a fluid. 6
- (c) A steel sphere of 1.6 mm diameter and mass 16.6 mg falls at its terminal velocity in oil of density 950 kg/m<sup>3</sup>, covers 300 mm in 34 s. Determine the viscosity of the oil neglecting wall effect. 8
8. (a) Describe one device to measure the flow of fluid through a pipe. Establish the mathematical relation to quantify the flow. 6 + 6
- (b) A pipeline of 2 km length has two pipes of 0.4 m and 0.5 m diameter in parallel. The total flow rate is 0.8 m<sup>3</sup>/s. If  $f = 0.006$ , determine the flow rate in each pipe and the loss of head in the system. 8

**Group C**

Choose the *correct* answer for the following: 1 x 20

(i) The Young's modulus of a material is 125 GPa and the Poisson's ratio is 0.25. The modulus of rigidity of the material is

(a) 25 GPa

(b) 75 GPa

(c) 50 GPa

(d) 100 GPa.

(ii) Principal plane is a plane on which the shear stress is

(a) zero

(b) maximum

(c) minimum

(d) None of the above.

(iii) A beam, which is fixed at one end and free at the other, is called

(a) cantilever beam

(b) overhanging beam

(c) simply-supported beam

(d) fixed beam.

(iv) The bending moment at the fixed end of a cantilever beam, whose length is  $l$  and carrying a UDL of  $w$  per unit length, is

(a)  $wl/2$

(b)  $wl$

(c)  $wl^2/2$

(d)  $wl/4$ .

(v) The polar modulus for a solid shaft of diameter  $D$  is

(a)  $\pi D^3/16$

(b)  $\pi D^3/32$

(c)  $\pi D^4/64$

(d)  $\pi D^4/32$ .

(vi) If a body floating in a liquid returns back to its original position, when given a small angular disturbance, the body is said to be in

(a) stable equilibrium

(b) unstable equilibrium

(c) neutral equilibrium

(d) None of the above.

(vii) A pressure less than the atmospheric pressure is known as

- (a) vacuum pressure
- (b) suction pressure
- (c) negative gauge pressure
- (d) All of the above.

(viii) According to Darcy's formula, the head loss due to friction in pipes is

- (a)  $flv^2/2gd$
- (b)  $flv^2/gd$
- (c)  $2flv^2/gd$
- (d) None of the above.

(ix) First law of thermodynamics deals with

- (a) conservation of heat
- (b) conservation of mass
- (c) conservation of energy
- (d) conservation of momentum.

(x) The sum of the internal energy and the product of pressure and volume is known as

- (a) work done
- (b) enthalpy
- (c) entropy
- (d) None of the above.

(xi) A series of thermodynamic processes, which take place in a certain order and restore the initial conditions at the end, is known as

- (a) reversible cycle
- (b) irreversible cycle
- (c) thermodynamic cycle
- (d) None of the above.

(xii) The efficiency of a Carnot cycle operating between the highest temperature,  $T_1$ , and lowest temperature,  $T_2$ , is

- (a)  $(T_1 / T_2) - 1$
- (b)  $1 - (T_1 / T_2)$
- (c)  $1 - (T_2 / T_1)$
- (d)  $(T_2 / T_1) - 1$ .

(xiii) The compression ratio of a diesel engine is

- (a) 20-30
- (b) 15-20
- (c) 5-10
- (d) 3-5.

(xiv) Which of the following material has maximum ductility?

- (a) MS
- (b) Copper
- (c) Nickel
- (d) Aluminium.

(xv) A couple produces

- (a) combined translatory and rotational motion.
- (b) only translatory motion.
- (c) only rotational motion.
- (d) None of the above.

(xvi) The point through which the whole weight of the body acts, irrespective of its position, is known as

- (a) moment of inertia
- (b) centre of gravity

(c) centre of percussion

(d) centre of mass.

(xvii) The moment of inertia of a rectangular section having width ( $b$ ) and depth ( $d$ ) about an axis passing through its centre of gravity and parallel to the width is

- (a)  $db^3/12$
- (b)  $bd^3/12$
- (c)  $bd^3/6$
- (d)  $db^3/6$ .

(xviii) The coefficient of friction depends on

- (a) area of contact
- (b) nature of surface
- (c) both (a) and (b) above
- (d) None of the above.

(xix) If the angular velocity of a particle is  $\omega$  rev/s, the time period is

- (a)  $\omega/2\pi$
- (b)  $2\pi/\omega$

(c)  $2\pi\omega$

(d)  $\pi/\omega$ .

(xx) The time period of oscillation for a simple pendulum is

(a)  $2\pi\sqrt{g/l}$

(b)  $2\pi\sqrt{l/g}$

(c)  $1/2\pi\sqrt{g/l}$

(d)  $1/2\pi\sqrt{l/g}$ .



**S'09 : 3FN : AN 205 (1405)****MECHANICAL SCIENCE***Time : Three hours**Maximum Marks : 100*

*Answer FIVE questions, taking ANY TWO from Group A,  
ANY TWO from Group B and ALL from Group C.*

*All parts of a question ( a,b,etc.) should  
be answered at one place.*

*Answer should be brief and to-the-point and be supplemented  
with neat sketches. Unnecessary long answer may  
result in loss of marks.*

*Any missing or wrong data may be assumed suitably giving  
proper justification.*

*Figures on the right-hand side margin indicate full marks.*

**Group A**

1. (a) Explain the concept of free body diagram. Draw the free body diagram of a ball of weight 'W' placed on a horizontal surface. 4
- (b) What are the laws of static friction ? 6
- (c) A uniform rod is resting against a rough vertical wall and rough ground. Show that the least angle that the rod can make with the ground without slipping is given by

*( Turn Over )*

$$\theta = \tan^{-1} \left( \frac{1 - \mu_1 \mu_2}{2\mu_2} \right)$$

where  $\mu_1$  and  $\mu_2$  stand for the coefficient of friction between the (i) rod and the wall, and (ii) rod and the ground. 10

2. (a) Define the following terms : 2 × 4

- (i) Static loads
- (ii) Dynamic loads
- (iii) Poisson's ratio
- (iv) Elastic modulus and shear modulus.

(b) A load of 500 kN is supported by a rod and cables AB and AC, as shown in Fig. 1. Neglecting the weight of the rod, determine the normal stresses in the rod and cables. 8

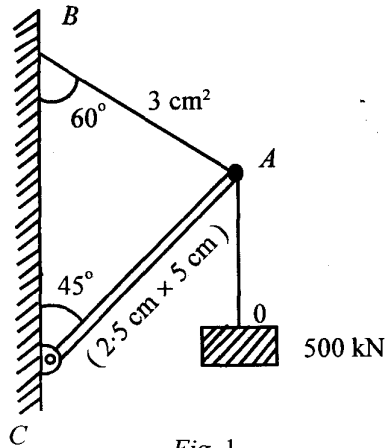

Fig. 1

(c) What is Mohr's circle ? What is its use ? 4

3. (a) For the overhang beam, shown in Fig. 2, draw the shear force and bending moment diagrams. 10

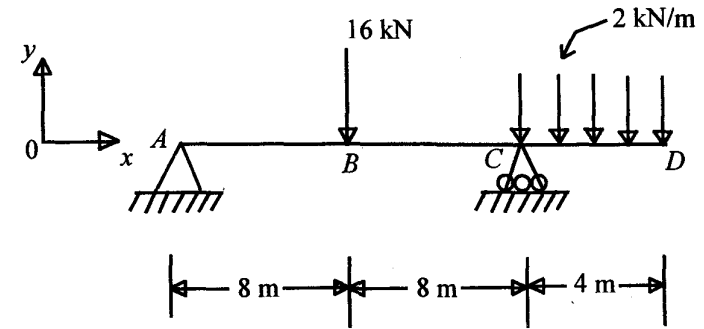

Fig. 2

(b) Prove that the torsional relation for a circular solid shaft subjected to a torque is given by  $\tau/r = G\theta/L$ , where  $\tau$  = shear stress at the surface;  $r$ , the radius of twist;  $L$ , the length of the twist;  $\theta$ , the angle of twist; and  $G$ , the shear modulus of shaft material. State the assumptions made for the derivation. 10

4. (a) Explain the principle of free vibration. Derive the equation of motion of a vertically moving undamped spring mass system. 8

(b) A block of mass  $m = 5$  kg rests on a smooth inclined surface of a wedge of mass  $M = 10$  kg (Fig. 3). The wedge is resting on a smooth horizontal surface. Assuming the pulley to be weightless, smooth and

frictionless and the string to be light and inextensible, find the acceleration of mass  $M$ . 6

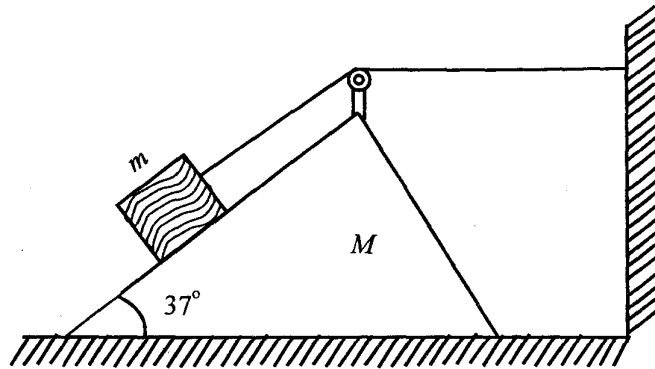

Fig. 3

(c) A solid shaft is required to transmit a torque of 4500 N-m. The twist of the shaft is not to exceed  $1^\circ$  over a length of 2 m. The shear modulus  $G$  of the shaft material is 133 GN/m<sup>2</sup>. Find the (i) diameter of the shaft, and (ii) maximum shear stress in the shaft. 6

### Group B

5. (a) Define the following terms : 1 × 5
- Thermodynamic system
  - Closed system
  - Open system
  - Thermodynamic work
  - Thermodynamic property.

(b) State the first law of thermodynamics for a closed system undergoing a cycle and prove that energy is a property of the system. 5

(c) Define the ideal gas and derive an expression for work done when an ideal gas undergoes a polytropic compression process. Sketch the process on  $P$ - $V$  and  $T$ - $S$  planes. 5

(d) A certain quantity of air has a volume of 0.028 m<sup>3</sup> at a pressure of 1.25 bar and 25 °C. It is compressed to a volume of 0.0042 m<sup>3</sup> according to the law  $pV^{1.3} = \text{constant}$ . Find the final temperature and work done during compression. 5

6. (a) State and explain the second law of thermodynamics with the help of an example of a heat pump cycle. 4

(b) Sketch the Carnot cycle on  $P$ - $V$  and  $T$ - $S$  planes and derive an expression for its thermal efficiency in terms of source and sink temperature. 5

(c) Sketch the ideal cycle for a diesel engine on  $P$ - $V$  and  $T$ - $S$  plane and derive an expression for its thermal efficiency in terms of compression ratio, cut-off ratio and ratio of specific heats. 6

(d) A reversible heat engine operates between two reservoirs at temperatures of 600 °C and 40 °C. The engine drives a reversible refrigerator which operates between reservoirs at temperatures of 40 °C and -20 °C. The heat transfer to the engine is 2 MJ and the net work output of the combined engine and refrigerator plant is 360 KJ. Find the heat transfer to refrigerant and the net heat transfer to the reservoir at 40 °C. 5

7. (a) Define the following terms :  $1 \times 5$
- Specific weight
  - Specific gravity
  - Newtonian fluid
  - Non-Newtonian fluid
  - Surface tension.
- (b) The space between two square flat parallel plates is filled with oil. Each side of the plate is 60 cm. The thickness of the oil film is 12.5 mm. The upper plate, which moves at 2.5 m/s, requires a force of 98.1 N to maintain the speed. Determine the
- dynamic viscosity of the oil (in poise), and
  - kinematic viscosity of oil in stokes, if the specific gravity of oil is 0.95.  $5$
- (c) What do you understand by total pressure and centre of pressure? Derive an expression for the force exerted on a submerged vertical plane surface by the static liquid.  $5$
- (d) Determine the total pressure on a circular plate of diameter 1.5 m which is placed vertically in water in such a way that the centre of the plate is 3 m below the free surface of water. Find the position of centre of pressure also.  $5$
8. (a) Distinguish between the following :  $1 \times 5$
- Steady flow and unsteady flow
  - Uniform and non-uniform flow
  - Compressible and incompressible flow
  - Rotational and irrotational flow
  - Laminar and turbulent flow.

- (b) What is a venturimeter? Derive an expression for the discharge through a venturimeter.  $8$
- (c) The inlet and throat diameters of a horizontal venturimeter are 30 cm and 10 cm, respectively. The liquid flowing through the meter is water. The pressure intensity at inlet is  $13.734 \text{ N/cm}^2$  while the vacuum pressure head at the throat is 37 cm of mercury. Find the rate of flow. Assume that 4% of the differential head is lost between the inlet and throat. Find the value of  $C_d$  for the venturimeter.  $7$

### Group C

9. Choose the *correct* answer for the following :  $1 \times 20$
- Which one of the following is an intensive property of thermodynamic system?
    - Volume
    - Temperature
    - Mass
    - Energy.
  - Work done in a free expansion process is
    - zero
    - minimum
    - maximum
    - positive
  - For a reversible adiabatic process, the change in entropy is
    - zero
    - minimum
    - maximum
    - unity.

7.

(iv) The value of  $C_p/C_v$  for air is

- (a) 1
- (b) 1.4
- (c) 1.8
- (d) 2.31

(v) The work done in a steady flow process is given by

(a)  $\int_1^2 PdV$

(b)  $-\int_1^2 PdV$

(c)  $\int_1^2 VdP$

(d)  $-\int_1^2 VdP$

(vi) The change of entropy when heat is absorbed by the gas is

- (a) positive
- (b) negative
- (c) positive or negative
- (d) zero.

8.

(vii) Which one of the following does not relate to SI engine ?

- (a) Ignition coil
- (b) Spark plug
- (c) Distributor
- (d) Fuel injector

(viii) Compressibility of a liquid is expressed by its

- (a) density
- (b) volume
- (c) specific volume
- (d) pressure.

(ix) Stream lines and path lines always coincide in

- (a) steady flow
- (b) uniform flow
- (c) non-uniform flow
- (d) laminar flow.

(x) Discharge is measured by

- (a) current meter
- (b) venturimeter
- (c) pitot tube
- (d) hot wire anemometer.

(xi) One atmospheric pressure in SI unit is equal to

- (a) 0.01 MPa
- (b) 1MPa
- (c) 0.1 MPa
- (d) None of the above.

(xii) The shear stress, in case of a pipe flow at the centre of the pipe, is

- (a) maximum
- (b) minimum
- (c) zero
- (d) negative.

S'09

S'09: 3FN: AN205(1405)

( 8 )

( Continued )

S'09: 3FN: AN205(1405)

( 9 )

( Turn Over )

(xiii) The relation between modulus of elasticity,  $E$ , modulus of rigidity,  $G$ , and Poisson's ratio,  $\mu$ , is

- (a)  $E = G (\mu + 1)$
- (b)  $E = G (\mu - 1)$
- (c)  $E = 2G (\mu + 1)$
- (d)  $E = 2G (\mu - 1)$

(xiv) The shear stress on principal plane is

- (a) maximum
- (b) minimum
- (c) zero
- (d) None of the above.

(xv) The radius of Mohr's circle for two unlike principal stresses of magnitude  $P$  is

- (a)  $P$
- (b)  $P/2$
- (c)  $P/4$
- (d) None of the above.

(xvi) A point of contraflexure in a beam occurs at a point, where

- (a) B.M. changes sign
- (b) S.F. changes sign
- (c) loading becomes zero
- (d) B.M. and S.F. become zero.

(xvii) A couple can be balanced by

- (a) a force
- (b) a moment

- (c) a torque
- (d) an equal and opposite couple.

(xviii) The path traced by a projectile is

- (a) circular
- (b) parabolic
- (c) elliptic
- (d) hyperbolic.

(xix) In a simple harmonic motion, the time of oscillation is given by

- (a)  $T = 2\pi/\omega$
- (b)  $T = 2\pi\omega$
- (c)  $T = 2\pi/\omega^2$
- (d)  $T = 2\omega/\pi$ .

(xx) Principle moment of inertia of a square of side,  $b$ , about an axis passing through its centre of gravity is

- (a)  $b^3/3$
- (b)  $b^4/3$
- (c)  $b^4/12$
- (d)  $b^4/8$

**W'09 : 3 FN : AN 205 (1405)****MECHANICAL SCIENCE***Time : Three hours**Maximum Marks : 100*

*Answer FIVE questions, taking ANY TWO from Group A, ANY TWO from Group B and ALL from Group C.*

*All parts of a question ( a, b, etc. ) should be answered at one place.*

*Answer should be brief and to-the-point and be supplemented with neat sketches. Unnecessary long answers may result in loss of marks.*

*Any missing or wrong data may be assumed suitably giving proper justification.*

*Figures on the right-hand side margin indicate full marks .*

**Group A**

1. (a) Along a ladder, supported at  $A$  and  $B$ , as shown in Fig. 1, a vertical load,  $W$ , can have any position as defined by the distance  $a$  from the bottom. Neglecting friction and the weight of the ladder, determine the magnitude of the reaction  $R_b$  at  $B$ . 6

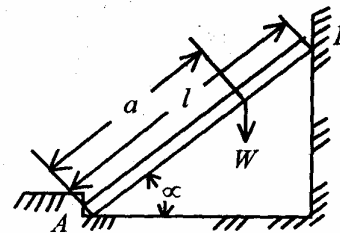

Fig. 1

- (b) A heavy block of weight 453 kgf resting on a horizontal floor supports another block of weight 226.5 kgf against the vertical wall and the wedged side. Find the minimum value of a horizontal force,  $P$ , applied to the lower block that will hold the system in equilibrium. The coefficient of friction between block and floor is 0.25, between the block and the wall 0.30, and between the blocks 0.20. Details of the arrangement are shown in Fig. 2.

8

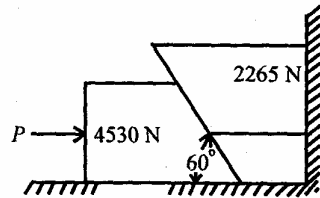

Fig. 2

- (c) Calculate the reactions  $R_a$  and  $R_b$  for the beam loaded as shown in Fig. 3. Neglect the weight of the beam.

6

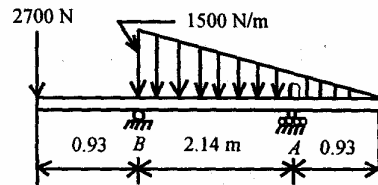

Fig. 3

- (a) The driver of an automobile, travelling along a straight level highway, suddenly applies the brakes so that the car slides for 2 sec covering a distance of 9.81 m before coming to a stop. Assuming that during this time the car moved with constant deceleration, find the coefficient of friction between the tires and the pavement.

8

- (b) The pilot of an aeroplane, flying horizontally with constant speed  $v=480$  kmph at an elevation  $h=610$  m above a level plane, wishes to bomb a target  $B$  on the ground (Fig 4). At what angle,  $\theta$ , below the horizontal should he see the target at the instant of releasing the bomb in order to score a hit? Neglect air resistance.

6

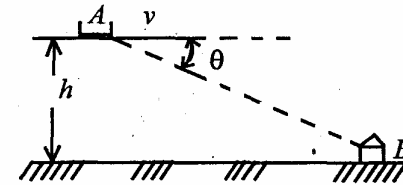

Fig. 4

- (c) Referring to the screw press, as shown in Fig. 5, and neglecting friction in the screw threads, find the relation between the moment of the couple acting in the plane perpendicular to the axis of the screw and the reaction  $Q$  of the compressed body.

6

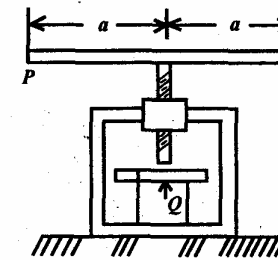

Fig. 5

3. (a) Find the centroid of a semi-circular lamina of radius  $r$ .

5



- (b) A simply-supported beam of length 6 m carries a triangular load whose intensity varies uniformly from 0 at the left-end to 60 kN/m at the right end. It has one support at 1.5 m from the left and the other support at the right end. Draw the shear force and bending moment diagrams for the beam. 10
- (c) A thin cylindrical drum, 800 mm in diameter and 3 m long, has a shell thickness of 10 mm. If the drum is subjected to an internal pressure of 2.5 N/mm<sup>2</sup>, determine the (i) change in diameter, and (ii) change in length. Take  $E = 2 \times 10^5$  N/mm<sup>2</sup> and Poisson's ratio = 0.25. 5
4. (a) A straight bar, 450 mm long, is 20 mm in diameter for the first 250 mm length and 10 mm diameter for the remaining length. If the bar is subjected to an axial pull of 10 kN, find the extension of the bar. Take  $E = 2 \times 10^5$  N/mm<sup>2</sup>. 8
- (b) A weight of 4.54 N is suspended vertically by a spring and vibrates with an amplitude of 75 mm and a frequency of 60 oscillations per minute. Find the (i) spring constant  $K$ , (ii) maximum tension induced in the spring, and (iii) maximum velocity of the weight. 8
- (c) State the laws of static equilibrium in two-dimensional problem. 4
- Group B**
5. (a) Explain the principle of operation of a four-stroke compression ignition engine. 6
- (b) Calculate the thermal efficiency of an engine working on the Otto cycle. The bore and stroke of the cylinder are 17 cm and 30 cm, respectively. The clearance volume is 0.002025 m<sup>3</sup>. Assume  $\gamma = 1.4$ . 6
- (c) The mean effective pressure of an ideal diesel cycle is 7.5 N/cm<sup>2</sup>. If the initial pressure is 1 N/cm<sup>2</sup> and the compression ratio is 12.5, determine the constant pressure cut-off ratio. Assume  $\gamma = 1.4$ . 8
6. (a) A mass of air of 0.45 kg at 179°C expands adiabatically to three times its original volume. During the process, there is a fall in temperature to 15.5°C. The work during the process is 5300 N-m. Calculate the values of  $C_p$  and  $C_v$ . 6
- (b) What is a reversible cycle? What are the thermodynamic processes in a reversible cycle? State the second law of thermodynamics. 6
- (c) Air is compressed in a reversible isothermal steady flow process from 1.03 N/cm<sup>2</sup> and 40°C to 10.3 N/cm<sup>2</sup>. Determine the work done on the gas per kg and the heat transferred. Also, determine the change of entropy per kg of the mass flow. Assume  $R = 29.27$  N-m/kg °K. 8
7. (a) Calculate the pressure due to a column of 0.3 m of (i) water, (ii) an oil of specific gravity 0.8, and (iii) mercury of specific gravity 13.6. Take specific weight of water,  $w = 1000$  N/m<sup>3</sup>. 6
- (b) What is the function of a manometer? Explain the principle of working of a differential manometer. 6

(c) A uniform body, 3 m long, 2 m wide and 1 m deep, floats in water. What is the weight of the body if depth of immersion is 0.8 m? Determine the metacentric height also. 8

8. (a) Water is flowing through a pipe having diameters 20 cm and 10 cm at section 1 and 2, respectively. The rate of flow through pipe is 35 litre/sec. The section 1 is 6 m above datum and section 2 is 4 m above datum. If the pressure at section 1 is  $4\text{ N/cm}^2$ , find the intensity of pressure at section 2. 6

(b) With the help of a suitable diagram, explain the working principle of a orifice meter. 6

(c) A lawn sprinkler, as shown in Fig.6, has 0.8 cm diameter nozzle at the end of a rotating arm and discharges water at the rate of 10 m/sec velocity. Determine the torque required to hold the rotating arm stationary. Also, determine the constant speed of rotation of the arm, if free to rotate. 8

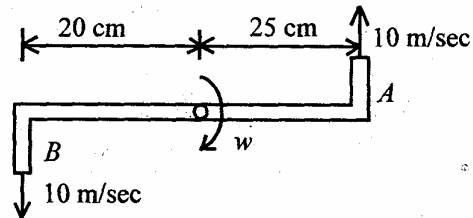

Fig. 6

**Group C**

9. (A) Choose the correct answer for the following:  $1 \times 15$

(i) The resultant of two forces, each equal to  $P/4$  and acting at right angle, is

(a)  $P/2$

(b)  $P/2\sqrt{2}$

(c)  $\sqrt{2}P$

(d)  $P/\sqrt{2}$ .

(ii) If a body is moving with a uniform acceleration  $f$ , the distance travelled by a body after time  $t$  is equal to

(a)  $ut + \frac{1}{2}ft^2$

(b)  $u + ft$

(c)  $u^2 + 2ft$ .

(d) None of the above.

(iii) The expression  $(\frac{1}{2}I\omega^2)$  represents

(a) centrifugal force

(b) kinetic energy

(c) kinetic energy of rotation

(d) potential energy.

(iv) A body is rotating with an angular velocity of 5 rad/sec. After 4 sec, the angular velocity of the body becomes 13 rad/sec. The angular acceleration of the body would be

(a) 3 rad/sec<sup>2</sup>

(b) 2 rad/sec<sup>2</sup>

(c) 1 rad/sec<sup>2</sup>

(d) 1.5 rad/sec<sup>2</sup>.

(v) The coefficient of friction ( $\mu$ ) in terms of angle of friction ( $\phi$ ) is given by

(a)  $\phi = \tan(\mu)$

(b)  $\mu = \sin(\phi)$

(c)  $\mu = \tan \phi$

(d)  $\mu = 1/\tan \phi$ .

(vi) The moment of inertia of a rectangular section, having  $b$  = width and  $d$  = depth, about  $x$ -axis, passing through the section and parallel to the width,  $b$ , is given by

(a)  $I_x = bd^3/12$

(b)  $I_x = b^3 d/2$

(c)  $I_x = b^2 d^2/6$

(d)  $I_x = 12/bd^3$ .

(vii) The relation between external torque ( $T$ ) acting on a body and the angular acceleration ( $\alpha$ ) is given by

(a)  $T = I\alpha$

(b)  $T = \alpha/I$

(c)  $T = I\alpha$

(d)  $I = T\alpha$ .

(viii) The acceleration of a particle moving with S.H.M. is maximum, when the particle is at

(a) its extreme position

(b) its mean position

(c) a point between its mean position and extreme position

(d) None of the above.

(ix) Stoke is the unit of

(a) surface tension

(b) viscosity

(c) kinematic viscosity

(d) energy.

(x) Surface tension has the unit of

(a) force per unit area

(b) force per unit length

(c) force per unit volume

(d) energy per unit energy.

(xi) For a floating body, the buoyant force passes through the

(a) centre of gravity of the body

(b) centre of gravity of the submerged part of the body

(c) metacentre of the body

(d) centroid of the liquid displaced by the body.

(xii) Pitot tube is used for measurement of

(a) pressure

(b) flow

(c) velocity at a point

(d) discharge.

(xiii) Bernoulli's theorem deals with the law of conservation of

(a) mass

(b) momentum

(c) energy

(d) volume.

(xiv) The loss of pressure head for the laminar flow through pipes varies

(a) as the square of velocity

(b) directly as the velocity

(c) inversely as the velocity

(d) None of the above.

(xv) Entropy is a measure of

(a) disorderliness

(b) temperature

(c) heat

(d) friction.

(B) Give one line definition/description of the following :

1 × 5

(i) Enthalpy

(ii) Law of conservation of energy

(iii) Cetane number

(iv) Detonation

(v) First law of thermodynamics.

**MECHANICAL SCIENCE**

*Time : Three hours*

*Maximum Marks : 100*

*Answer FIVE questions, taking ANY TWO from Group A, ANY TWO from Group B and ALL from Group C.*

*All parts of a question (a, b, etc.) should be answered at one place.*

*Answer should be brief and to-the-point and be supplemented with neat sketches. Unnecessary long answers may result in loss of marks.*

*Any missing or wrong data may be assumed suitably giving proper justification.*

*Figures on the right-hand side margin indicate full marks.*

**Group A**

1. (a) A smooth circular cylinder of radius 1.5 m is lying in a triangular groove, one side of which makes  $15^\circ$  angle and the other  $40^\circ$  angle with the horizontal. Find the reactions at the surfaces of contact, if there is no friction and the cylinder weighs 2 kN. 6
  
- (b) A uniform ladder of 7 m length rests against a vertical wall with which it makes an angle of  $45^\circ$ . The coefficient of friction between the ladder and the wall is  $1/3$  and that between the ladder and the floor is  $1/2$ . If a person, whose weight is one-half of that of the ladder, ascends it, how high will it be when the ladder slips? 8

- (c) (i) Derive, from first principles, the moment of inertia of a circular lamina about its centroidal axes. 4
- (ii) What is the moment on inertia of a hollow circular lamina of external diameter  $D$  and internal diameter  $d$  about a diametral axis? 2
2. (a) A bullet, moving at the rate of 300 m/s, is fired into a thick block of target and penetrates up to 0.5 m. If it is fired into a 0.25 m thick target, find the velocity of emergence. The two block are of same material and take the resistance to be uniform in both the cases. 6
- (b) A particle is projected with a velocity of 5 m/s at an elevation of  $60^\circ$  to the horizontal. Find the velocity of projection of another particle thrown at an angle of  $45^\circ$  which will have equal (i) horizontal range, (ii) maximum height, and (iii) time of flight. 8
- (c) A ball is dropped from a height of 100 cm on a smooth floor. The height of the first bounce is 81 cm. Determine the (i) coefficient of restitution, and (ii) expected height of the second bounce. 6
3. (a) The state of stress at a point of an elastic material is as shown in Fig. 1:

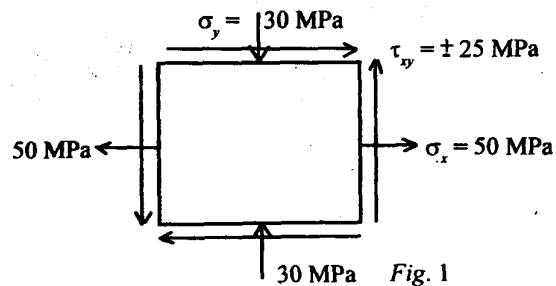

S'10: 3FN: AN 205 (1405)

( 2 )

(Continued)

Find the (i) principal stresses and the position of principal planes, and (ii) maximum shear stress and its plane. Use Mohr's circle method for above calculations. 3 + 3

- (b) Draw the stress-strain diagram from the tensile test conducted on a mild steel rod specimen and show the salient points on the curve. How do you determine the Young's modulus ( $E$ ) of the material from this test? 6
- (c) A thin cylindrical pressure vessel has an external diameter 53 cm, wall thickness 1 cm, and length 183 cm. Determine the increase in its internal diameter and length when it is subjected to a fluid pressure of 10.5 MPa. Take  $E = 210$  GPa and Poisson's ratio = 0.3. 8
4. (a) Draw the shear force and bending moment diagrams of a simply-supported beam of span  $L$  and flexural rigidity  $EI$  and loaded by a uniformly distributed load  $q$  spread over the entire length of the beam. 6
- (b) Find the central deflection of the above beam. 6
- (c) A steel shaft, 10 cm in diameter, is subjected to a pure torque and is 20 m long. It is driven at one end while the power is taken off at the other end. The angle of twist of the shaft over the whole length has been measured to be  $30^\circ$ . Find the (i) maximum shear stress in the shaft, and (ii) torque transmitted. Take modulus of rigidity of the material as 80 GPa. 4 + 4

**Group B**

5. (a) An oil of viscosity 5 poise is used for lubrication between a shaft and a sleeve. The diameter of the shaft is 0.5 m and it rotates at 200 r.p.m. Calculate the power lost in oil for a sleeve length of 100 mm. The thickness of oil film is 1.0 mm. 6
- (b) Differentiate between (i) absolute and gauge pressure, and (ii) simple and differential manometer (with a neat sketch). 4 + 4
- (c) Determine the total pressure and centre of pressure on an isosceles triangular plate of base 4 m and altitude 4 m when it is immersed vertically in an oil of specific gravity 0.9. The base of the plate coincides with the free surface of oil. 6
6. (a) A solid cylinder of diameter 4 m has a height of 3 m. Find the metacentric height of the cylinder when it is floating in water with its axis vertical. The specific gravity of the cylinder = 0.6. 6
- (b) Write the Bernoulli's equation for real fluid. Take into account the loss of energy between points 1 and 2 of the real fluid. 4
- (c) The molar mass of a perfect gas is 26 kg/k mol and it has  $\gamma = 1.26$ . Calculate the heat rejected when unit mass of the gas is contained in a rigid vessel at 3 bar and 315°C, and is then cooled until the pressure falls to 1.5 bar. 6
- (d) State and explain first law of thermodynamics. 4

7. (a) One kg of nitrogen gas (molar mass 28 kg/k mol) is compressed reversibly and isothermally from 1.01 bar, 20°C to 4.2 bar. Calculate the (i) work done, and (ii) heat flow during the process. Presume nitrogen to be a perfect gas. 6
- (b) (i) Write the expression for efficiency  $\eta$  of an ideal air standard cycle based on Otto cycle. 3
- (ii) Calculate the same for a petrol engine with a cylinder bore of 50 mm, a stroke of 75 mm, and a clearance volume of 21.3 cm<sup>3</sup>. 3
- (c) State and explain equivalence of Kelvin-Planck and Clausius statement of second law of thermodynamics. Explain the same with respect to a cyclic heat engine. 8
8. (a) How does a four-stroke compression ignition engine work? Explain the same for a diesel engine. 8
- (b) List the main differences between SI and CI engine cycles. 6
- (c) Explain, with a neat sketch, how the air-fuel mixture is controlled in a petrol engine. How does the ignition take place in such an engine? 6

**Group C**

9. Define/state/write the expression in brief for the following : 10 × 2
- (i) Laws of friction.
- (ii) Principle of virtual work.

- (iii) Position of the centroid of a semi-circular lamina.**
- (iv) Relation between Young's modulus ( $E$ ), shear modulus ( $G$ ) and Poisson's ratio ( $\nu$ ).**
- (v) Torsional rigidity of transmission shaft.**
- (vi) Newton's law of viscosity.**
- (vii) Entropy.**
- (viii) Second law of thermodynamics.**
- (ix) Efficiency of Carnot cycle.**
- (x) Enthalpy.**



**W'10:3FN:AN 205 (1405)****MECHANICAL SCIENCE***Time : Three hours**Maximum Marks : 100*

*Answer FIVE questions, taking ANY TWO from Group A,  
ANY TWO from Group B and ALL from Group C.*

*All parts of a question (a, b, etc.) should  
be answered at one place.*

*Answer should be brief and to-the-point and be supplemented  
with neat sketches. Unnecessary long answers may  
result in loss of marks.*

*Any missing or wrong data may be assumed suitably giving  
proper justification.*

*Figures on the right-hand side margin indicate full marks.*

**Group A**

1. (a) A smooth sphere of weight,  $W$ , is supported in contact with a smooth vertical wall by a string fastened to a point on its surface, the other end being attached to a point on the wall. If the length of the string is equal to the radius of the sphere, find the tension in the string and the reaction of the wall. 6
  
- (b) A body, resting on a rough horizontal plane, required a pull of 180 N at  $30^\circ$  to the plane just to move it. It was found that a push of 220 N, inclined at  $30^\circ$  to the plane, just moved the body. Determine the weight of the body and the coefficient of friction. 6

- (c) A framed structure is loaded as shown in Fig. 1. Find the reactions and forces in members of the truss.

8

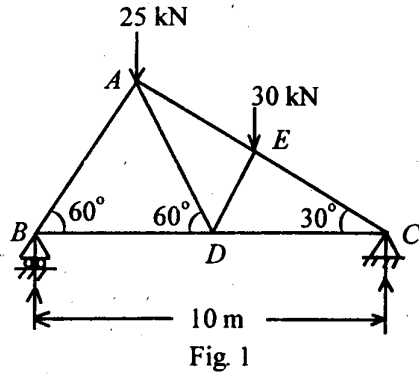

2. (a) Determine the centroid of the area shown in Fig 2 with respect to  $x - y$  axes:

5

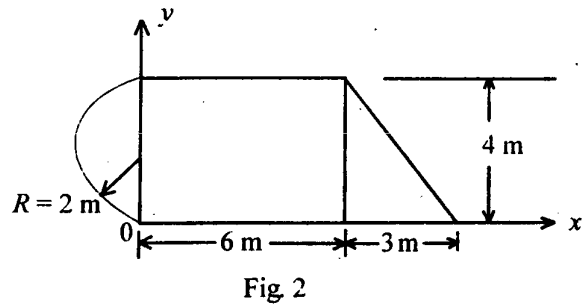

- (b) Find the mass moment of inertia of a circular plate of radius,  $R$ , and thickness,  $t$ , about its centroidal axis. Density of material is  $\rho$  and total mass is  $M$ .

5

- (c) A motorist is travelling at 80 kmph, when he observes a traffic light 200 m ahead of him turns red. The traffic light is timed to stay red

for 10 sec. If the motorist wishes to pass the light without stopping, just as it turns green, determine the (i) required uniform deceleration, and (ii) speed as it passes the light.

5

- (d) A bullet is fired from a height of 120 m at a velocity of 360 kmph at an angle of  $30^\circ$  upward. Neglecting air resistance, find (i) total time of flight, (ii) horizontal range of the bullet, (iii) maximum height reached by the bullet, and (iv) final velocity of the bullet just before touching the ground.

5

3. (a) Draw the stress ( $\sigma$ )-strain ( $\epsilon$ ) curve for steel from the observations made from a tensile test on a round bar specimen. Show all the salient points. Explain how do you get the value of Young's modulus ( $E$ ).

6

- (b) The state of stress at a given point in a loaded machine member is shown in Fig 3.

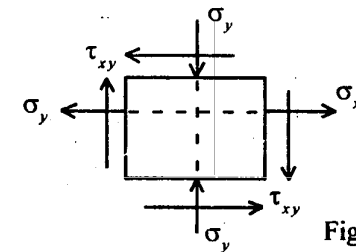

Fig 3

$\sigma_x = 50 \text{ MPa}$ ,  $\sigma_y = -35 \text{ MPa}$ ,  $\tau_{xy} = \pm 40 \text{ MPa}$ .

- Find (i) principal stresses and their directions, and (ii) maximum shear stress.

4 + 4

- (c) A thin cylindrical shell of internal diameter,  $d$ , and thickness,  $t$ , is subjected to internal fluid

pressure  $p$ . Derive the expressions for hoop (circumferential) stress and longitudinal stress in the shell. What is the expression for maximum shear stress ?

6

4. (a) A beam, 10 m long, is simply-supported at its ends and carries concentrated loads of 30 kN and 50 kN at distances of 3 m from each end. Draw the SFD and BMD and indicate the maximum values.

6

- (b) Compare the weights of equal lengths of hollow and solid shaft to transmit a given torque for the same maximum shear stress, if the inside diameter is two-third of the outside diameter.

6

- (c) State and explain the principle of virtual work.

4

- (d) A solid hemisphere of weight 120 N and radius 1 m rests with its flat face on a table. How many N-m of work are required to turn it over that it may rest with its curved surface in tangential contact with the table ?

4

### Group B

5. (a) Calculate the dynamic viscosity of an oil, which is used for lubrication between a square plate of size  $0.8 \text{ m} \times 0.8 \text{ m}$  and an inclined plane with angle of inclination  $30^\circ$ . The weight of the square plate is 300 N and it slides down the inclined plane with a uniform velocity of  $0.3 \text{ m/s}$ . The thickness of oil film is  $1.5 \text{ mm}$ .

6

- (b) The pressure outside the droplet of water of diameter  $0.04 \text{ mm}$  is  $10.32 \text{ N/cm}^2$ . Calculate the pressure within the droplet if surface tension is given as  $0.0725 \text{ N/m}$  of water.

4

- (c) An open drum contains water  $1.5 \text{ m}$  deep. It is resting on an elevator. Calculate the gauge pressure at the bottom of the drum when the elevator is (i) stationary, (ii) accelerating upwards at the rate of  $3 \text{ m/s}^2$ , and (iii) accelerating downwards at the rate of  $3 \text{ m/s}^2$ .

4

- (d) Figure 4 shows a gate having a quadrant shape of radius  $2 \text{ m}$ . Find the resultant force due to water per meter length of the gate. Also, find the angle at which the total force will act.

6

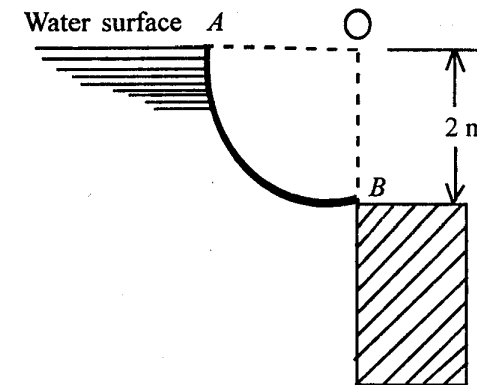

Fig. 4

6. (a) An open circular cylinder of  $15 \text{ cm}$  diameter and  $100 \text{ cm}$  long contains water up to a height of  $70 \text{ cm}$ . Find the speed at which the cylinder is to be rotated about its vertical axis so that the axial depth becomes zero.

4

- (b) A rectangular pontoon is  $5 \text{ m}$  long,  $3 \text{ m}$  wide and  $1.2 \text{ m}$  high. The depth of immersion of the pontoon is  $0.8 \text{ m}$  in sea-water. If the centre of gravity is  $0.6 \text{ m}$  above the bottom of the pontoon, determine the metacentric height. The density of sea-water =  $1025 \text{ kg/m}^3$ .

4

- (c) Derive the expression for work done in the following quasi-static processes: (i)  $pV = C$ , and (ii)  $pV^n = C$ . 8
- (d) Unit mass of a certain fluid is contained in a cylinder at an initial pressure of 20 bar. The fluid is allowed to expand reversibly behind a piston according to a law  $pV^2 = \text{constant}$  until the volume is doubled. The fluid is then cooled reversibly at constant pressure until the piston regains its original position; heat is then supplied reversibly with the piston firmly locked in position until the pressure rises to original value of 20 bar. Calculate the network done by the fluid for an initial volume of  $0.05 \text{ m}^3$ . 4
- (a) State and explain (i) first law of thermodynamics, and (ii) law of conservation of energy. 6
- (b) Air flows steadily at the rate of  $0.5 \text{ kg/s}$  through an air compressor, entering at  $7 \text{ m/s}$  velocity,  $100 \text{ kPa}$  pressure and  $0.95 \text{ m}^3/\text{kg}$  volume, and leaving at  $5 \text{ m/s}$ ,  $700 \text{ kPa}$  and  $0.19 \text{ m}^3/\text{kg}$ . The internal energy of the air leaving is  $90 \text{ kJ/kg}$  greater than that of the air entering. Cooling water in the compressor jackets absorbs heat from the air at the rate of  $58 \text{ kW}$ .
- (i) Compute the rate of shaft work input to the air (in kW). 4
- (ii) Find the ratio of the inlet pipe diameter to outlet pipe diameter. 4
- (c) In compression stroke of an IC engine, the heat rejected to the cooling water is  $45 \text{ kJ/kg}$  and the work input is  $90 \text{ kJ/kg}$ . Calculate the change in specific internal energy of the working fluid stating whether it is a gain or loss. 6

8. (a) State second law of thermodynamics. 4
- (b) Describe entropy and irreversibility. Give a suitable example. 4
- (c) Distinguish between the principle of operation of SI and CI engines. 6
- (d) Show the following processes on  $T$ - $s$  diagram: 3 + 3
- (i) Reversible isothermal process
- (ii) Reversible adiabatic (isentropic) process.

### Group C

9. Answer the following in brief:  $10 \times 2$
- (i) Distinguish between Newton's law and D'Alembert's principle.
- (ii) Define the condition for self-locking for square thread used in screw jack.
- (iii) Define coefficient of restitution in connection with impact of elastic or plastic bodies.
- (iv) Write the relation between Young's modulus ( $E$ ), Poisson's ratio ( $\nu$ ) and shear modulus ( $G$ ). Also, write the relation between  $E$ ,  $\nu$  and bulk modulus ( $K$ ).
- (v) Define Poisson's ratio. How is it measured?
- (vi) What is a throttling device?
- (vii) Distinguish between detonation and knocking in SI and CI engine performance.
- (viii) Define the thermal efficiency of a heat engine cycle. Can this be 100%?
- (ix) What is viscosity? How is it measured?
- (x) What do you mean by metacentric height in connection with study of floating bodies?

**S'11:3FN:AN 205 (1405)****MECHANICAL SCIENCE***Time : Three hours**Maximum Marks : 100*

*Answer FIVE questions, taking ANY TWO from Group A,  
ANY TWO from Group B and ALL from Group C.*

*All parts of a question (a, b, etc.) should  
be answered at one place.*

*Answer should be brief and to-the-point and be supplemented  
with neat sketches. Unnecessary long answers may  
result in loss of marks.*

*Any missing or wrong data may be assumed suitably giving  
proper justification.*

*Figures on the right-hand side margin indicate full marks .*

**Group A**

1. (a) What is a vector? Why is 'force' considered to be a vector? Is energy a vector? 4
- (b) The system of forces, all in newtons, is shown in Fig. 1. Determine the magnitude and direction of the resultant force. 8

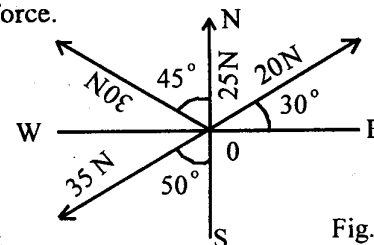

Fig. 1

*( Turn Over )*

(c) A lever AB rests horizontally on a fulcrum at C such that  $AC = a$  and  $CB = b$ . Two loads, each of magnitude  $Q$ , are acting on the left of C, one at the free end A and the other mid-way between A and C. Three loads, each of magnitude  $P$ , are acting on the right of C, one at the free end B, the second at a distance of  $b/3$  on the left of B and the third at a distance of  $b/3$  on the right of C. If  $Q = 2P$  and the weight of lever is negligible, determine the ratio  $a : b$  of an arm of the lever if it is in equilibrium. 8

2. (a) Find the centre of gravity of the E-section shown in Fig.2 with respect to the point O. All dimensions are in mm. 6

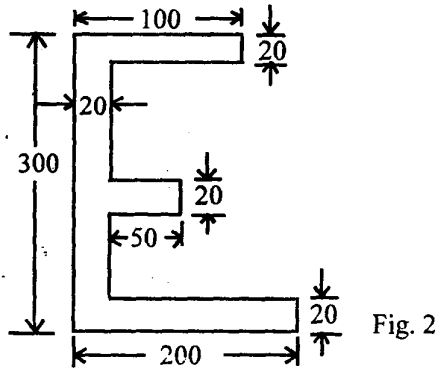

Fig. 2

(b) Define the radius of gyration. Determine the moment of inertia of an inverted T-section of a flange of  $100 \text{ mm} \times 10 \text{ mm}$  and web of  $120 \text{ mm} \times 12 \text{ mm}$  about both the centroidal axes (Fig. 3). 6

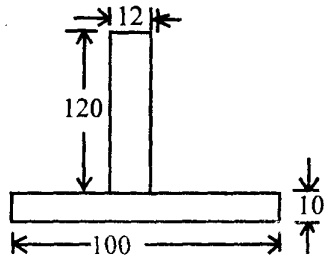

Fig. 3

(c) A ladder, shown in Fig. 4, is 4 m long and is supported by a horizontal floor and a vertical wall. The coefficient of friction at the wall is 0.25 and at the floor is 0.50. The weight of the ladder is 20 kg considered concentrated at G. The ladder also supports a vertical load of 100 kg at C. Determine the reactions at A and B and compute the least value of  $\alpha$  at which the ladder may be placed without slipping to the left. 8

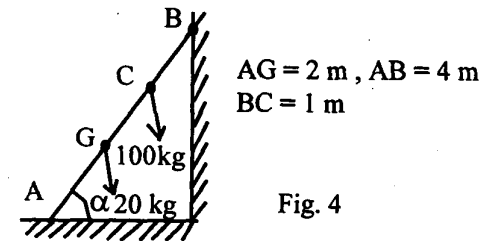

Fig. 4

3. (a) Derive an expression for the time taken by a body, projected vertically upwards with a velocity  $u$ , to reach a height  $h$ . 4

(b) A stone after falling from rest for 4 sec breaks a glass pane and in breaking it loses 25% of its velocity. How far will it fall in the next second? 4

(c) A cricket ball thrown from a height of 1.8 m at an angle of  $30^\circ$  from the horizontal with a velocity of 18 m/s is caught by a fieldsman at a height of 60 cm from the ground. How far apart were the two men? 6

(d) An engine of mass 50 tonnes pulls a train of mass 250 tonnes up a gradient of 1 in 120 with a uniform speed of 36 kmph. Find the power exerted by the engine, if the tractive resistance is 60 N per tonne. 6

4. (a) Draw the stress-strain diagrams of mild steel and cast iron and explain the difference. 5
- (b) Define the following : (i) Modulus of elasticity, (ii) Modulus of rigidity, (iii) Bulk modulus, and (iv) Poisson's ratio. 5
- (c) What is strain energy? Show that the strain energy per unit volume is  $\sigma^2 / 2E$ . 4
- (d) A point is subjected to a tensile stress of  $60 \text{ kN/m}^2$  and a compressive stress of  $40 \text{ kN/m}^2$ , acting on two mutually perpendicular planes, and a shear stress of  $12 \text{ kN/m}^2$  on these planes. Determine the principal stresses as well as the maximum shear stress. 6

**Group B**

5. (a) What do you mean by capillarity? Estimate the rise of water in a capillary tube of 1 mm inner radius at  $20^\circ\text{C}$ . Given :  $\sigma = 7.28 \times 10^{-2} \text{ N/m}$ . 4
- (b) A conical tube is fixed vertically with its smaller end upwards and it forms a part of a pipeline. The velocity at the smaller end is  $4.5 \text{ m/s}$  and at the larger it is  $1.5 \text{ m/s}$ . The length of the conical tube is  $1.5 \text{ m}$ . The pressure at the upper end is equivalent to a head of  $10 \text{ m}$  of water. Neglecting friction, determine the pressure at the lower end of the tube. 6

- (c) A circular plate of 1 m diameter is immersed in water so that the vertical distance of its perimeter lies between  $0.5 \text{ m}$  and  $1.5 \text{ m}$  below the water surface as shown in Fig . 5. Find the total hydrostatic force acting on one side of the plate and the vertical depth of the centre of pressure below the water surface. 8

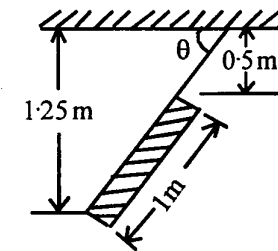

Fig. 5

- (d) What are the instruments you can use to measure the flow rate of a fluid? 2
6. (a) Show that the energy of a fluid is a property. What are different modes in which energy may be stored in a system? 6
- (b) A mass of  $8 \text{ kg}$  gas expands within a flexible container so that the  $p-v$  relationship is of the form  $pv^{1.2}$  constant. The initial pressure is  $1000 \text{ kPa}$  and the initial volume is  $1 \text{ m}^3$ . The final pressure is  $5 \text{ kPa}$ . If the specific internal energy of the gas decreases by  $40 \text{ kJ/kg}$ , find the heat transfer in magnitude and direction. 8
- (c) How does the current flowing through a resistor represent work transfer? Under what conditions is the work done equal to  $\int_1^2 p dv$ ? 6

- (c) parabolic path.  
(d) curvilinear path.
- (v) The time period of oscillation of a simple pendulum depends upon  
(a) the mass of the suspended body.  
(b) length of the pendulum.  
(c) angular displacement of the pendulum.  
(d) tension of the string.
- (vi) The normal component of acceleration of a particle moving with a uniform speed of 4 m/s along a circular path of radius 20 cm is given by  
(a) zero  
(b) 800 m/s  
(c) 5 m/s<sup>2</sup>  
(d) 80 m/s<sup>2</sup>
- (vii) The centre of gravity of a right circular solid cone of height  $h$  is at this distance from the apex along the axis.  
(a)  $h/3$   
(b)  $h/4$   
(c)  $(3/4)h$   
(d)  $(2/3)h$ .
- (viii) The centre of pressure in a fluid  
(a) is always below the centroid of the submerged area.  
(b) exists for any curved surface having single or double curvature.
- (c) is independent of the orientation of the area.  
(d) is the point on the submerged area at which the resultant hydrostatic force is supposed to act.
- (ix) It is not an extensive property of a system :  
(a) Volume  
(b) Pressure  
(c) Energy  
(d) Entropy
- (x) Heat supplied to a system at constant pressure increases its  
(a) internal energy.  
(b) volume.  
(c) enthalpy.  
(d) pressure.
- (B) Write in brief (3-4 lines) about the following : 5 × 2
- (i) Varignon's theorem  
(ii) Mohr's circle of stresses  
(iii) Viscous fluid flow  
(iv) Clausius' theorem  
(v) Otto cycle



**W'11:3FN:AN 205 (1405)****MECHANICAL SCIENCE***Time : Three hours**Maximum Marks : 100*

*Answer FIVE questions, taking ANY TWO from Group A,  
ANY TWO from Group B and ALL from Group C.*

*All parts of a question (a, b, etc.) should  
be answered at one place.*

*Answer should be brief and to-the-point and be supplemented  
with neat sketches. Unnecessary long answers may  
result in loss of marks.*

*Any missing or wrong data may be assumed suitably giving  
proper justification.*

*Figures on the right-hand side margin indicate full marks.*

**Group A**

1. (a) Three identical cylinders, each weighing  $W$ , are stacked as shown in Fig. 1, on smooth inclined surfaces, each inclined at an angle  $\theta$  with the horizontal. Determine the smallest angle  $\theta$  to prevent the stack from collapsing. 9

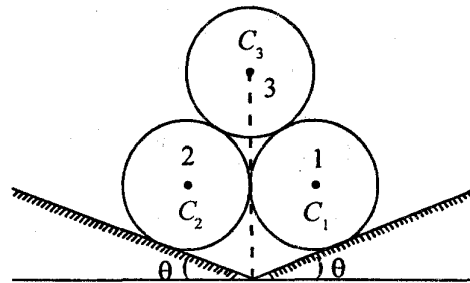

Fig. 1

- (b) State the Coulomb's law of dry friction. 3
- (c) A man wishes to climb a 5m long ladder placed at 60° on a horizontal surface ( $\mu = 0.3$ ) against a vertical wall ( $\mu = 0.2$ ). How far can he climb without the ladder slipping? The man and the ladder weigh 800 N and 150 N, respectively. 8

2. (a) Define efficiency of a screw jack. 2
- (b) A screw thread of a screw jack has a mean diameter of 10 cm and a pitch of 1.25 cm. The coefficient of friction between the screw and its nut-housing is 0.25. Determine the force  $F$  that must be applied at the end of a 50 cm lever arm to raise a mass of 5000 kg. Is the device self-locking? Also, determine its efficiency? 6
- (c) A large balloon is rising up with a velocity of 9.81 m/s at an altitude of 39.2 m from the ground. At that instant, a stone of mass 5 kg is dropped from it. After how many seconds will the stone reach the ground? 5
- (d) Locate the centroid of the given composite area shown in Fig. 2: 7

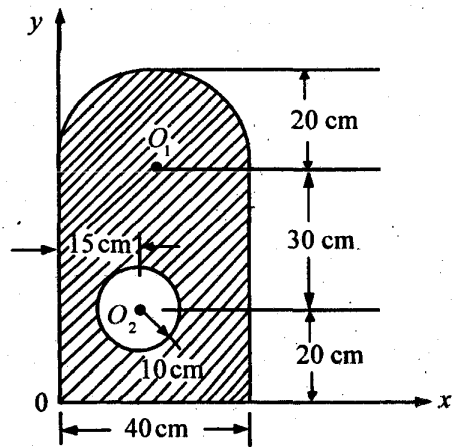

Fig. 2

3. (a) Determine the moments of inertia with respect to the centroidal axes of the wide-flange beam section shown in Fig. 3. 5

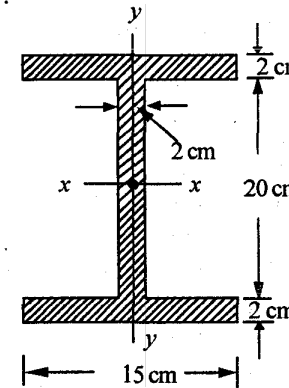

Fig. 3

- (b) An elevator ascends with an upward acceleration of 1.2 m/s<sup>2</sup>. At the instant when the upward speed is 2.4 m/s, a loose bolt drops from the ceiling of the elevator located 2.75 m from its floor. Calculate the (i) time of flight of the bolt from ceiling to floor of the elevator, (ii) displacement and the distance covered by the bolt during free fall relative to elevator shaft. 6
- (c) A small motor of mass 20 kg is symmetrically mounted on four equal springs, each with a spring constant of 25 N/cm. Estimate the frequency and period of vibration of the motor. 3
- (d) What is Mohr's circle? What is its significance? 6
4. (a) Draw the shear force and bending moment diagrams for the beam loaded as shown in Fig. 4. 12

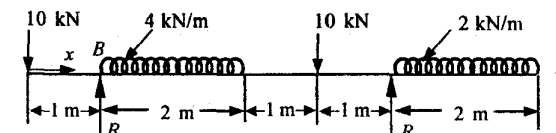

Fig. 4

- (b) Calculate the diameter of the solid shaft required to transmit a torque of 4500 Nm. The twist of the shaft not to exceed  $1^\circ$  over a length of 2 m. The shear modulus  $G$  of the shaft material is  $133 \text{ GN/m}^2$ . Also, calculate the maximum shear stress in the shaft. 8

### Group B

5. (a) The space between two square flat parallel plates is filled with oil. Each side of the plate is 60 cm. The thickness of the oil film is 12.5 mm. The upper plate, which moves at 2.5 m/s, requires a force of 98.1 N to maintain the speed. Determine the (i) dynamic viscosity of the oil in poise, and (ii) kinematic viscosity of oil in stokes, if the specific gravity of oil is 0.95. 6
- (b) Calculate the capillary rise in a glass tube of 2.5 mm diameter when immersed vertically in (i) water, and (ii) mercury. Take surface tension  $\sigma = 0.0725 \text{ N/m}$  for water and  $\sigma = 0.52 \text{ N/m}$  for mercury in contact with air. The specific gravity of mercury is given as 13.6 and angle of contact =  $130^\circ$ . 4
- (c) A circular opening, 3m diameter in a vertical side of a tank, is closed by a disc of 3 m diameter which can rotate about a horizontal diameter. Calculate the (i) force on the disc; and (ii) torque required to maintain the disc in equilibrium in vertical position when the head of water above the horizontal diameter is 4 m. 4
- (d) The water is flowing through a pipe having diameters 20 cm and 10 cm at sections 1 and 2, respectively. The rate of flow through pipe is 35 litre/s. The section 1 is 6 m above datum and section 2 is 4 m above datum. If the pressure at section 1 is  $39.24 \text{ N/cm}^2$ , find the intensity of pressure at section 2. 6

6. (a) Define the following terms :  $4 \times 1$
- (i) Ideal gas  
(ii) Constant volume specific heat  
(iii) Enthalpy  
(iv) Universal gas constant.
- (b) For a reversible adiabatic process, prove that  $Pv^r = \text{constant}$ , where  $r$  is the ratio of specific heats. Show the process on  $P - v$  and  $T - s$  co-ordinates. 8
- (c) A cylinder contains  $0.45 \text{ m}^3$  of a gas at 1 bar and  $80^\circ \text{ C}$ . The gas is compressed to a volume of  $0.13 \text{ m}^3$ , the final pressure being 5 bar. Determine the (i) mass of gas, (ii) index 'n' for compression, (iii) change in internal energy, (iv) heat transfer. Take  $\gamma = 1.4$ ,  $R = 294.2 \text{ J/kg K}$ . 8
7. (a) State the first law of thermodynamics for a closed system undergoing a cycle, and prove that energy is a property. 6
- (b) Prove that the efficiency of air standard Otto cycle increases with increase in compression ratio. 6
- (c) At the inlet to a certain nozzle, the enthalpy of fluid passing is  $2800 \text{ kJ/kg}$ , and the velocity is 50 m/s. At the discharge end, the enthalpy is  $2600 \text{ kJ/kg}$ . The nozzle is horizontal and there is negligible heat loss from it. (i) Find the velocity at exit of the nozzle, (ii) If the inlet area is  $900 \text{ cm}^2$  and the specific volume at inlet is  $0.187 \text{ m}^3/\text{kg}$ , find the mass flow rate, and (iii) If the specific volume at the nozzle exit is  $0.498 \text{ m}^3/\text{kg}$ , find the exit area of nozzle. 8
8. (a) Write the two statements of second law of thermodynamics. 4

- (b) A Carnot engine operates between two reservoirs at temperatures  $T_1$  °K and  $T_2$  °K. The output of the heat engine is 0.6 times the heat rejected. Given that the difference in temperatures between source and sink is 200°C, calculate the (i) source temperature; (ii) sink temperature, and (iii) thermal efficiency. 5
- (c) One kg of water at 0°C is brought into contact with a heat reservoir at 90°C. When the water has reached 90°C, find (i) entropy change of water, (ii) entropy change of heat reservoir, and (iii) entropy change of universe. 5
- (d) An engine of 250 mm bore and 375 mm stroke works on Otto cycle. The clearance volume is 0.00263 m<sup>3</sup>. The initial pressure and temperature are 1 bar, 50°C. If the maximum pressure is 25 bar, find (i) efficiency, and (ii) pressure at the end of compression. 6

### Group C

9. Choose the *correct* answer for the following : 10 × 2
- (i) The centre of gravity of a hemisphere of radius  $r$  from its base measured along vertical radius is
- (a)  $4r/3$   
 (b)  $3r/2$   
 (c)  $3r/8$   
 (d)  $4r/7$
- (ii) A couple can be balanced by
- (a) a force.  
 (b) a moment.  
 (c) a torque.  
 (d) an equal and opposite couple.

- (iii) Thin cylinder vessel of diameter 100 mm wall thickness 2.5 mm is subjected to an internal water pressure of 1.5 N/mm<sup>2</sup>. The maximum stress developed in cylinder wall is
- (a) 15 N/mm<sup>2</sup>  
 (b) 30 N/mm<sup>2</sup>  
 (c) 60 N/mm<sup>2</sup>  
 (d) 120 N/mm<sup>2</sup>
- (iv) The radius of Mohr's circle for two unlike principal stresses of magnitude  $P$  is
- (a)  $P$   
 (b)  $P/2$   
 (c)  $P/4$   
 (d) None of the above.
- (v) Which one of the following devices is used to measure the velocity of a fluid in a pipe ?
- (a) Venturimeter  
 (b) Pitot tube  
 (c) Orifice meter  
 (d) Manometer.
- (vi) For a reversible adiabatic process, the change in entropy is
- (a) zero.  
 (b) minimum.  
 (c) maximum.  
 (d) unity.

- (vii) Which one of the following is the extensive property of a thermodynamic system ?
- (a) Pressure
  - (b) Volume
  - (c) Temperature
  - (d) Density
- (viii) In a isothermal process,
- (a) volume remains constant.
  - (b) temperature increases gradually.
  - (c) change in internal energy is zero.
  - (d) pressure remains constant.
- (ix) If two forces of magnitude  $P$  act at an angle  $\theta$ , then the resultant force will be
- (a)  $2P \cos (\theta/2)$
  - (b)  $2P \sin \theta$
  - (c)  $2P \cos \theta$
  - (d)  $P \cos 2\theta$
- (x) For unstable equilibrium of submerged body,
- (a) centre of buoyancy is below centre of gravity.
  - (b) centre of buoyancy is above centre of gravity.
  - (c) centre of buoyancy coincides with centre of gravity.
  - (d) None of the above.

**S'12:5FN:AN205 (1405)****MECHANICAL SCIENCE***Time : Three hours**Maximum Marks : 100*

*Answer FIVE questions, taking ANY TWO from Group A, ANY TWO from Group B and ALL from Group C.*

*All parts of a question (a, b, etc.) should be answered at one place.*

*Answer should be brief and to-the-point and be supplemented with neat sketches. Unnecessary long answers may result in loss of marks.*

*Any missing or wrong data may be assumed suitably giving proper justification.*

*Figures on the right-hand side margin indicate full marks.*

**Group A**

1. (a) A lever  $AB$  rests horizontally on a fulcrum at  $C$  such that  $AC = a$  and  $CB = b$ . Two loads, each of magnitude  $Q$ , acting on the left of  $C$ , one at the free end  $A$  and the other midway between  $A$  and  $C$ . Three loads, each of magnitude  $P$ , acting on the right of  $C$ , one at the free end  $B$ , the second at a distance of  $b/3$  on the left of  $B$  and the third at a distance of  $b/3$  on the right of  $C$ . If  $Q = 2P$  and the weight of the lever is negligible, determine the ratio  $a : b$  of the arm of the lever, if it is in equilibrium. 7

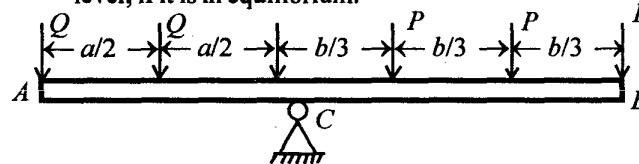

- (b) Explain Varignon's theorem. 3

( Turn Over )

(c) A uniform ladder AB of 7 m length rests against a vertical wall B with which it makes an angle of  $45^\circ$ , the coefficient of friction between the ladder and wall is  $1/3$  and that between the ladder and floor is  $1/2$ . A man, whose weight is half of that of the ladder, ascends it. What will be the distance from A on the ladder when the ladder slips ? 10

2. (a) Find the centre of gravity of the E-section with respect to the point O, as shown in Fig. 1. All dimensions are in mm. 7

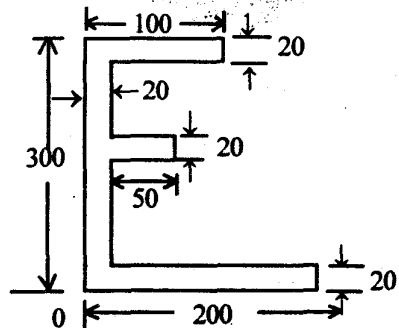

Fig. 1

(b) What do you mean by radius of gyration ? 3

(c) Find the moment of inertia of an I-section about its centroidal axes (Fig. 2) having top flange 60 mm x 10 mm, bottom flange 120 mm x 10 mm and web 100 mm x 10 mm. 10

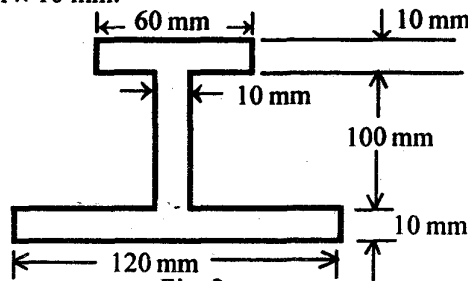

Fig. 2

S'12:5FN:AN205 (1405)

( 2 )

( Continued )

3. (a) In a lifting machine, an effort of 98.2 N raised a load of 1000 N and an effort of 498.2 N raised a load of 6000 N. Find the law of the machine. What is the effort required to lift a load of 10,000 N ? Find the maximum mechanical advantage. 10

(b) Derive an expression for the time taken by a body projected vertically upwards with a velocity  $u$  to reach a height  $h$ . 4

(c) A stone, after falling from rest, breaks a glass pane and in breaking it loses 25% of its velocity. How far will it fall in the next second ? Take  $g = 9.81 \text{ m/s}^2$ . 6

4. (a) A ball is projected from the ground at an angle of  $60^\circ$  with the horizontal with a velocity of 40 m/s. Find the distance covered by the ball vertically and horizontally after 2 sec. 6

(b) Explain what you understand by strain energy. Show that the strain energy of a body per unit volume is  $\sigma^2/2E$ . 6

(c) Two elastic bars of the same material and length, one of circular section of diameter 120 mm and the other square of side 120 mm, absorb the same amount of strain energy delivered by axial forces. Compare the stress induced in two bars. 5

(d) What is meant by bending stress ? 3

**Group B**

5. (a) A 2 mm diameter glass tube is immersed in mercury. Estimate the depression, if the surface tension for mercury is 0.472 N/m and the contact angle is  $125^\circ$ . Take for Hg,  $\rho = 13.6 \times 10^3 \text{ kg/m}^3$ . 5

S'12:5FN:AN205 (1405)

( 3 )

( Turn Over )

- (b) The bearing of an engine is 10 cm in diameter and 5 cm long. The engine runs at 3000 rpm. The clearance between the bearing and the shaft is 0.5 mm and the viscosity of the lubricating oil is 0.44 Ns/m<sup>2</sup>. Assuming that the velocity in oil film varies linearly with the radius, calculate the power lost in the bearing. 8
- (c) A submarine is cruising at a depth of 15 m below the sea surface. If the forward speed of the submarine is 16 km/h, calculate the pressure at the front stagnation point. Take density of seawater as 1026 kg/m<sup>3</sup>. 7
6. (a) What is displacement work? Under what conditions is the work done equal to  $\int pdV$ ? 4
- (b) A mass of gas is compressed in a quasi-static process from 80 kPa, 0.1 m<sup>3</sup> to 0.4 MPA, 0.03 m<sup>3</sup>. Assuming that the pressure and volume are related by  $pv^n = \text{constant}$ , find the work done by the gas system. 6
- (c) A piston and cylinder machine contains a fluid system which passes through a complete cycle of four processes. During a cycle, the sum of all heat transfers is -170 kJ. The system completes 100 cycles/min. Complete the following table and compute the network output (in kW): 10
- | Process | $Q$ , kJ/min | $W$ , kJ/min | $\Delta E$ , kJ/min |
|---------|--------------|--------------|---------------------|
| a - b   | 0            | 2170         | —                   |
| b - c   | 21,000       | 0            | —                   |
| c - d   | -2100        | —            | -36,600             |
| d - a   | —            | —            | —                   |
7. (a) In a steady flow apparatus, 135 kJ of work is done per kg of fluid. The specific volume, pressure and velocity at inlet are 0.37 m<sup>3</sup>/kg, 600 kPa and 16 m/s. The inlet

is 32 m above the floor, and the discharge pipe is at the floor level. The discharge conditions are 0.62 m<sup>3</sup>/kg, 100 kPa and 270 m/s. The total heat loss between the inlet and exit is 9 kJ/kg. In flowing through the apparatus, does the specific internal energy increase or decrease, and by how much? 10

- (b) To produce net work in a cycle, a heat engine has to exchange heat with two thermal reservoirs. Explain. 3
- (c) Explain why all spontaneous processes are irreversible. 3
- (d) What is a heat pump? Show that the COP of a heat pump is greater than the COP of a refrigerator by unity. 4
8. (a) Water flows through a turbine in which friction causes the water temperature to rise from 35 °C to 37 °C. If there is no heat transfer, how much does the entropy of the water change in passing through the turbine? 5
- (b) Why is an isentropic process not necessarily an adiabatic process? 3
- (c) What is a spark ignition engine? What is the air standard cycle of such an engine? Show that this efficiency depends only on the compression ratio. Why does the compression ratio of an SI engine get restricted? 12

**Group C**

9. (A) Choose the *correct* answer for the following: 10 × 1
- (i) The C.G. of a right circular solid cone of height  $h$  is at a distance of
- (a)  $h/2$



- (b)  $h/3$
- (c)  $h/4$
- (d)  $3/4 h$

from the apex along the central axis.

- (ii) The body which does not deform under the action of applied forces is known as a
- (a) solid body.
  - (b) non-plastic body.
  - (c) rigid body.
  - (d) hard body.
- (iii) The path of an object thrown into the space under gravity at a certain angle is called a
- (a) projectile.
  - (b) trajectory.
  - (c) parabolic path.
  - (d) curvilinear path.
- (iv) The normal component of acceleration of a particle moving with a uniform speed of 4 m/s along a circular path of radius 20 cm is given by
- (a) zero.
  - (b)  $800 \text{ m/s}^2$
  - (c)  $5 \text{ m/s}^2$
  - (d)  $80 \text{ m/s}^2$ .
- (v) The cyclic integral of following one is zero :
- (a) Work transfer
  - (b) Heat transfer
  - (c) Temperature
  - (d) Latent heat.

- (vi) The following one does not change during a throttling process :
- (a) Enthalpy
  - (b) Entropy
  - (c) Specific volume
  - (d) Pressure.
- (vii) When a system is in equilibrium, any conceivable change in entropy would be
- (a) maximum.
  - (b) zero
  - (c) minimum.
  - (d) positive.
- (viii) For an ideal gas, following one is a function of temperature only.
- (a) Specific heat
  - (b) Internal energy
  - (c) Entropy
  - (d) Volume.
- (ix) The efficiency of a reversible cycle depends upon the
- (a) nature of the working substance.
  - (b) amount of the working substance.
  - (c) temperatures of the two reservoirs between which the cycle operates.
  - (d) type of cycle followed.
- (x) A pitot tube is used to measure the
- (a) state of the fluid.
  - (b) velocity of the fluid.
  - (c) density of the fluid.
  - (d) viscosity of the fluid.

(B) Write short notes on *any five* of the following : 5 × 2

- (i) Quasi-static process
- (ii) PMM2
- (iii) Ideal fluid
- (iv) Principal stress
- (v) Centre of pressure
- (vi) Bernoulli's equation
- (vii) Carnot cycle
- (viii) Poisson's ratio.

**W'12: 5 FN: AN 205 (1405)****MECHANICAL SCIENCE***Time : Three hours**Maximum Marks : 100*

*Answer FIVE questions, taking ANY TWO from Group A, ANY TWO from Group B and ALL from Group C.*

*All parts of a question ( a, b, etc. ) should be answered at one place.*

*Answer should be brief and to-the-point and be supplemented with neat sketches. Unnecessary long answer may result in loss of marks.*

*Any missing or wrong data may be assumed suitably giving proper justification.*

*Figures on the right-hand side margin indicate full marks*

**Group A**

1. (a) State and prove Lami's theorem. 4
- (b) A machine weighing 5 kN is supported by two chains attached to some point on the machine. One chain goes to the hook in the ceiling and has an inclination of  $45^\circ$  with the horizontal. The other chain goes to the eye bolt in the wall and is inclined at  $30^\circ$  to the horizontal. Make calculations for the tension induced in the chain. 8
- (c) Forces equal to  $P$ ,  $2P$ ,  $3P$ , and  $4P$  act along the sides AB, BC, CD and DA of a square ABCD. Find the magnitude, direction and line of action of the resultant. 8

- (b)  $2\sqrt{2} P$   
 (c)  $2 P$   
 (d)  $\sqrt{5} P$
- (v) When a wire is stretched to double its length, the longitudinal strain produced in it is  
 (a) 0.5  
 (b) 1.0  
 (c) 1.5  
 (d) 2.0
- (vi) A steel rod passes through a brass tube which is closed by thin rigid washers and fastened by acts screwed to the rod. Which will be the type of stress induced in the tube when the nut is tightened on the bolt?  
 (a) Tensile  
 (b) Compressive  
 (c) Shear  
 (d) Bending
- (vii) First law of thermodynamics refers to conservation of  
 (a) mass.  
 (b) momentum.  
 (c) energy.  
 (d) force.
- (viii) For a closed system, the difference between heat added to and work done by the system is equal to  
 (a) enthalpy.  
 (b) internal energy.  
 (c) Gibbs function.  
 (d) flow work.
- (ix) For practical petrol engine working on Otto cycle, the compression ratio usually lies in the range  
 (a) 3-5  
 (b) 6-8  
 (c) 10-15  
 (d) 16-22
- (x) The compression ratio for a practical diesel engine usually lies in the range  
 (a) 3-5  
 (b) 6-8  
 (c) 10-15  
 (d) 16-22

2. (a) Where does the centre of gravity of the following section lies ? (i) Semi-circle, (ii) trapezium, (iii) hemisphere, (iv) triangle, and (v) right circular solid cone. 5
- (b) State and prove the theorem of perpendicular axis as applied to moment of inertia. 5
- (c) Find the moment of inertia of a hollow section shown in Fig.1 about an axis passing through it and centre of gravity or parallel to X-X axis. 10

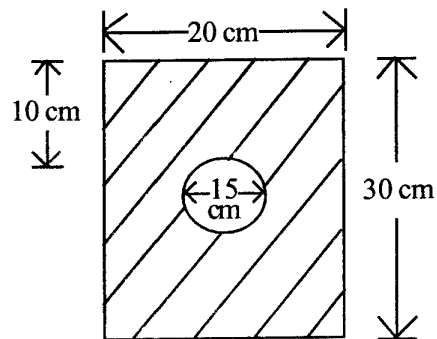

Fig. 1

3. (a) Define force, work, momentum and impulse. 4
- (b) The relation  $a = 2t$  defines the motion of a particle. It is given that  $s = 1.2$  m and  $v = 0.6$  m/s when  $t = 1$  sec. Find  $s$  and  $v$  at  $t = 4$  sec. 8
- (c) A 150 kg scooterist is travelling with a speed of 36 kmph on a road that makes an angle of  $30^\circ$  with another road upon which a 60 kg cyclist is travelling at 8 kmph. When they approach the crossing, they collide and move as one mass. Determine the final velocity, both in magnitude and direction. 8

4. (a) State Hooke's law. Distinguish between limit of proportionality and elastic limit. 4
- (b) A reinforced column 50 cm  $\times$  50 cm in section is reinforced with 4 steel bar of 2.5 cm diameter, one in each corner. The column is carrying a load of 200 tonnes. Find the stresses in the concrete and steel bar. Take  $E$  for steel =  $2.1 \times 10^6$  kg/cm<sup>2</sup> and  $E$  for concrete =  $0.14 \times 10^6$  kg/cm<sup>2</sup>. 8
- (c) A simply-supported beam of 4 m long is subjected to two point loads of 2 kN and 4 kN, each at distances of 1.5 m and 3 m from the left end. Draw S.F. and B.M. diagrams for the beam. 8

**Group B**

5. (a) Explain the terms 'viscosity' and 'surface tension'. 4
- (b) Prove that the relationship between surface tension and pressure inside a droplet of liquid in excess of outside pressure is given by  $p = 4 \sigma/d$ . 4
- (c) Two large plane surfaces are 2.4 cm apart. The space between the surface is filled with glycerine. What is the force required to drag a very thin plate of surface area 0.5 m<sup>2</sup> between the two large plane surface at a speed of 0.6 m/s, if the (i) thin plate is in middle of the two plane surface, and (ii) thin plate is at a distance of 0.8 cm from one of the plane surface ? Take the dynamic viscosity of glycerine =  $8.10 \times 10^{-1}$  Ns/m<sup>2</sup>. 12
6. (a) Derive an expression for total pressure and centre of pressure for a vertically immersed surface. 10
- (b) A rectangular plane surface is 2 m wide and 3 m deep. It lies in vertical plane in water. Determine the total pressure and position of centre of pressure on the plane surface when its upper edge is horizontal

and (i) coincides with water surface, and (ii) 2.5 m below the free water surface. 10

7. (a) What is the essence of first law of thermodynamics? Write expressions for the first law applied to (i) a cycle, and (ii) a process. 4
- (b) Explain the perpetual motion machine of first kind. 4
- (c) A perfect gas undergoes the following three separate and distinct processes to execute a cycle :
- (i) Constant volume process during which 80 kJ of heat is supplied to the gas.
- (ii) Constant pressure process during which 85 kJ of heat is lost to the surrounding and 20 kJ of work is done on it.
- (iii) Adiabatic process which restores the gas back to its initial state.
- Evaluate the work done during adiabatic process and the value of internal energy at all the state point, if initially its value is 95 kJ. 12
8. (a) State the limitations of first law of thermodynamics. 4
- (b) State the Kelvin-Planck and Clausius statements of the second law of thermodynamics. 4
- (c) Three Carnot heat engines are arranged in series. The first engine takes 4000 kJ of heat from a source at 2000 K and delivers 1800 kJ of work. The second and third engines deliver 1200 kJ and 500 kJ of work, respectively. Make calculations for the exhaust temperature of the second and third Carnot engine. 12

W'12 : 5 FN : AN 205 (1405)

(4)

(Continued)

**Group C**

9. Choose the *correct* answer for the following : 10 × 2

- (i) A real practical fluid possesses which one of the following :
- (a) Viscosity
- (b) Surface tension
- (c) Compressibility
- (d) Density
- (ii) Which one of the following is an example of phenomenon of surface tension ?
- (a) Rain drops
- (b) Rise of sap in tree
- (c) Break-up of liquid jet
- (d) All of the three above.
- (iii) Which one of the following is not a projectile ?
- (a) A ball thrown upwards.
- (b) A stone thrown horizontally from the top of a tower.
- (c) A rocket fired into space.
- (d) A bullet fired from the gun.
- (iv) Four forces  $P$ ,  $2P$ ,  $3P$  and  $4P$  act along the sides taken in order of a square. The resultant force is
- (a) 0

W'12 : 5 FN : AN 205 (1405)

(5)

(Turn Over)

**S'13 : 5 FN : AN 205 (1405)****MECHANICAL SCIENCE***Time : Three hours**Maximum Marks : 100*

*Answer FIVE questions, taking ANY TWO from Group A,  
ANY TWO from Group B and ALL from Group C.*

*All parts of a question ( a, b, etc. ) should be  
answered at one place.*

*Answer should be brief and to-the-point and be supple-  
mented with neat sketches. Unnecessary long answer may  
result in loss of marks.*

*Any missing or wrong data may be assumed suitably  
giving proper justification.*

*Figures on the right-hand side margin indicate full marks.*

**Group A**

1. (a) State the law of parallelogram of forces. 3
- (b) Find the magnitude of two forces such that, when they act at right angle, their resultant is  $\sqrt{10}$  N, but if they act at  $60^\circ$ , the resultant is  $\sqrt{13}$  N. 7
- (c) What are the characteristics of a couple? 3
- (d) A horizontal beam AB of 30 m long rests on two supports at its ends and carries concentrated loads of 3 kN, 4 kN and 5 kN at 4 m, 10 m and 14 m, respectively from the left hand support A. Find the supporting forces or the reactions at the two ends. Neglect the weight of the beam. 7
2. (a) Define centre of gravity and centroid of an area. 4

- (b) Find the position of centre of gravity of a semi-circle of radius 15 cm. Deduce the formula used. 5
- (c) State the theorem of parallel axes. 3
- (d) Determine the moment of inertia of an inverted T-section of flange 100 mm × 10 mm and web 120 mm × 12 mm about both the centroidal axes (Fig. 1): 8

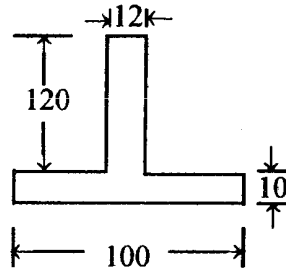

Fig. 1

- 3. (a) State the laws of static friction. If the angle of friction between two surfaces of contact is  $15^\circ$ , what is the value of coefficient friction? 3
- (b) A block of stone, weighing 20 N, is resting on a plane which is inclined to the horizontal at an angle of  $30^\circ$ . A force,  $P$ , is acting on the block in direction parallel to the inclined plane. The coefficient of static friction between the block and the inclined plane is 0.2. Find the magnitude of  $P$  (i) when the block is on the point of sliding up the plane, and (ii) when the block is on the point of sliding down the plane (Fig.2):

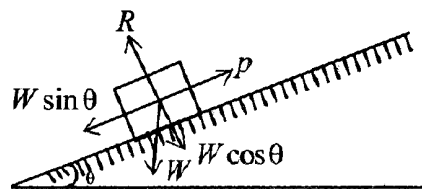

Fig. 2

- (c) Derive an expression for the time taken by a body, projected upwards with a velocity  $u$  to reach a height  $h$ . 3
- (d) A stone falling from rest breaks a glass pane and in breaking it loses 25% of its velocity. How far will it fall in the next second? Take  $g = 9.81 \text{ m/s}^2$ . 7
- 4 (a) Define (i) Poisson ratio, (ii) modulus of rigidity, and (iii) strain energy. 3 × 2
- (b) A bar 30 mm × 30 mm × 250 mm long is subjected to a pull of 90 kN in the direction of its length. The extension of the bar was found to be 0.125 mm, while the decrease in each lateral dimension is found to be 0.00375 mm. Find the Young's modulus, Poisson's ratio and modulus of rigidity for the material of the bar. 7
- (c) Draw the shearing force and bending moment diagrams for a simply-supported beam carrying a (i) concentrated load, and (ii) uniformly distributed load. 5
- (d) Show that the bending moment becomes maximum when the shearing force changes its sign. 2

**Group B**

- 5. (a) Write Bernoulli's equation and describe the various terms in it. For what kind of flow is the equation valid? 5
- (b) A conical tube is fixed vertically with its smaller end upwards and it forms a part of pipeline. The velocity at the smaller end is 4.5 m/s and at the larger end it is 1.5 m/s. The length of the conical tube is 1.5 m. The pressure at the upper (smaller) end is equivalent to a head of 10 m of water. Neglecting friction, determine the pressure at the lower end of the tube. 7



- (c) What do you mean by capillary effect? 2
- (d) Estimate the rise of water ( $P = 1000 \text{ kg/m}^3$ ) in a capillary tube of 2 mm diameter at  $20^\circ\text{C}$ , assuming that the density of air is negligible and the surface tension is  $0.0728 \text{ N/m}$ . 6
6. (a) Explain the difference between energy in transit and energy in storage. What is the energy per unit mass for a (i) non-flow system, and (ii) a flow system? 6
- (b) A gas of 4 kg mass is contained within a piston-cylinder machine. The gas undergoes a process for which  $pv^{1.5} = \text{constant}$ . The initial pressure is 3 bar and the initial volume is  $0.1 \text{ m}^3$ , and the final volume is  $0.2 \text{ m}^3$ . The internal energy of the gas decreases by  $4.6 \text{ kJ/kg}$ . Neglecting kinetic and potential energy changes, determine the net heat transfer for the process. 12
- (c) What do you mean by PMM1? 2
7. (a) How does Bernoulli's equation compare with steady flow energy equation? 4
- (b) Air enters a compressor operating at steady state at a pressure of 1 bar, a temperature of  $290 \text{ K}$  and a velocity of  $6 \text{ m/s}$  through an inlet of area  $0.1 \text{ m}^2$ . At exit, the pressure is 7 bar, the temperature is  $450 \text{ K}$  and the velocity is  $2 \text{ m/s}$ . Heat transfer from the compressor to the surroundings occurs at the rate of  $180 \text{ kJ/min}$ . Assuming that air behaves as an ideal gas with  $C_p = 1.005$  and  $R = 0.287 \text{ kJ/kg/K}$ , determine the power input to the compressor. 12
- (c) What is the difference between a nozzle and a diffuser? 4
8. (a) Give the Kelvin-Planck statement of the second law. Explain its significance. 4
- (b) What is the difference between a refrigerator and a heat pump? How do their COPs differ? 5
- (c) Explain the Carnot heat engine cycle. Does the nature of its working fluid have any effect on its efficiency? 5
- (d) A reversible power cycle operates between a reservoir at temperature  $T$  and a lower temperature reservoir at  $200 \text{ K}$ . At steady state, the cycle develops  $40 \text{ kW}$  of power while rejecting  $1000 \text{ kJ/min}$  by heat transfer to the cold reservoir. Determine the value of  $T$ . 6
- Group C**
9. (A) Choose the correct answer for the following:  $10 \times 1$
- (i) The path of an object thrown into the space under gravity at a certain angle is called
- (a) projectile.
- (b) trajectory.
- (c) parabolic path.
- (d) curvilinear path.
- (ii) A flywheel, which makes  $300 \text{ rpm}$  about its centroidal axis, has angular velocity equal to
- (a)  $10\pi \text{ rad/s}$ .
- (b)  $(5\pi/2) \text{ rad/s}$ .
- (c)  $(2\pi/5) \text{ rad/s}$ .
- (d)  $300\pi \text{ rad/s}$ .

(iii) The normal component of acceleration of a particle moving with a uniform speed of 4 m/s along a circular path of radius 20 cm is given by

- (a) zero.
- (b)  $800 \text{ m/s}^2$ .
- (c)  $5 \text{ m/s}^2$ .
- (d)  $80 \text{ m/s}^2$ .

(iv) The body which does not deform under the action of applied forces is known as

- (a) solid body.
- (b) non-plastic body.
- (c) rigid body.
- (d) hard body.

(v) 'If three forces acting at a point are in equilibrium, each force is proportional to the sine of the angle between other two forces.' This is the statement according to

- (a) Varignon's theorem
- (b) Lami's theorem
- (c) Triangular theorem
- (d) Co-planar force diagram.

(vi) A pitot tube is used for measuring

- (a) state of the fluid.
- (b) velocity of fluid.
- (c) density of fluid.
- (d) viscosity of fluid.

(vii) Dynamic viscosity has the dimension of

- (a)  $\text{MLT}^{-2}$
- (b)  $\text{ML}^{-1}\text{T}^{-1}$
- (c)  $\text{ML}^{-1}\text{T}^{-2}$
- (d)  $\text{M}^{-1}\text{L}^{-1}\text{T}^{-1}$

(viii) Heat transferred to a system at constant volume increases its

- (a) enthalpy.
- (b) internal energy.
- (c) volume.
- (d) pressure.

(ix) It is *not* an extensive property :

- (a) Volume
- (b) Pressure
- (c) Energy
- (d) Entropy

(x) The cyclic integral of this is zero

(a) Work transfer

(b) Heat transfer

(c) Temperature

(d) Latent heat

(B) Explain *any five* of the following in brief:  $5 \times 2$

(i) Varignon's theorem

(ii) Polar moment of inertia

(iii) Laws of lifting machine

(iv) Simple harmonic motion

(v) Reynolds number

(vi) Energy reservoir

(vii) Bulk modulus of elasticity

(viii) Ultimate stress.

**W'13 : 5 FN : AN 205 (1405)**

**MECHANICAL SCIENCE**

*Time : Three hours*

*Maximum Marks : 100*

*Answer FIVE questions, taking ANY TWO from Group A, ANY TWO from Group B and ALL from Group C.*

*All parts of a question ( a, b, etc. ) should be answered at one place.*

*Answer should be brief and to-the-point and be supplemented with neat sketches. Unnecessary long answer may result in loss of marks.*

*Any missing or wrong data may be assumed suitably giving proper justification.*

*Figures on the right-hand side margin indicate full marks.*

**Group A**

1. (a) What is free body diagram ? Explain with an example. 6
- (b) Determine the horizontal force,  $F$ , to be applied to the block weighing 1500 N to hold it in position on a smooth inclined plane AB which makes an angle of  $30^\circ$  with the horizontal as shown in Fig. 1 : 6

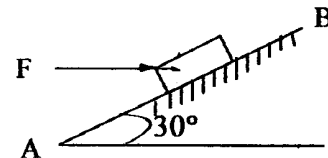

Fig. 1

- (c) Two identical cylinders, each weighing 500 N, are placed in a trough as shown in Fig. 2. Determine the reaction developed at contact points A, B, C and D.

Assume all points of contact are smooth.

8

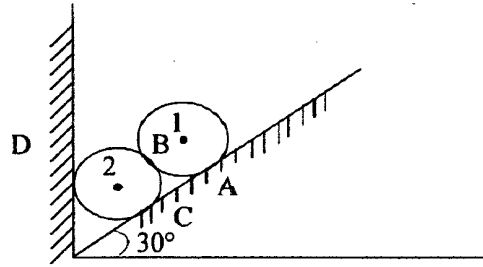

Fig. 2

2. (a) Define (i) angle of friction, (ii) angle of limiting friction, and (iii) angle of repose. 3 × 2

- (b) Block A weighing 1000 N rests over block B which weighs 2000 N as shown in Fig. 3. Block A is tied to wall with a horizontal string. If the coefficient of friction between blocks A and B is 0.25 and between B and floor is 1/3, what should be the value of P to move the block B, if P is horizontal ? 6

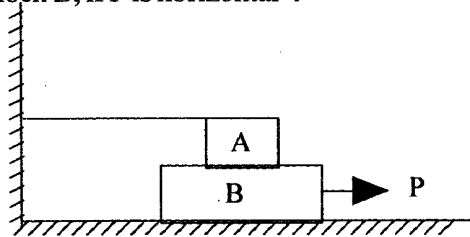

Fig. 3

- (c) A ladder of length 4 m, weighing 200 N, is placed against a vertical wall as shown in Fig. 4. The coefficient of friction between the wall and ladder is 0.2 and that between the floor and the ladder is 0.3. In addition to self-weight, the ladder has to support a man weighing 600 N at a distance of 3 m from A. Calculate the minimum horizontal force to be applied at A to prevent slipping. 8

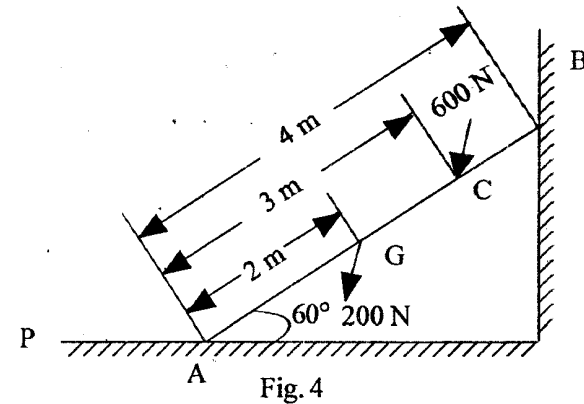

Fig. 4

3. (a) Define (i) area of moment of inertia, (ii) mass moment of inertia, and (iii) centroid. 3 × 2

- (b) A screw jack raises a load of 40 kN. The screw is square threaded having three threads per 20 mm length and 40 mm in diameter. Calculate the force required at the end of a lever 400 mm long measured from the axis of the screw, if the coefficient of friction between screw and nut is 0.12. 7

- (c) Find the centroid of the unequal angle 200 mm × 150 mm × 12 mm shown in Fig. 5. 7

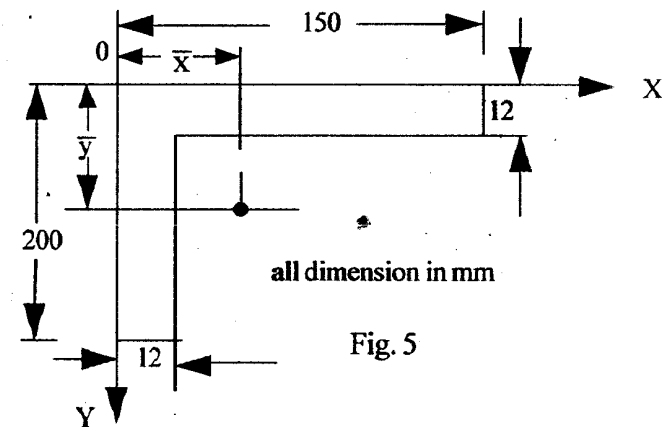

Fig. 5

4. (a) A projectile is aimed at a target on the horizontal plane and falls 12 m short when the angle of projection is  $15^\circ$ , while it overshoots by 24 m when the angle is  $45^\circ$ . Find the angle of projection to hit the target. 6
- (b) Draw the stress ( $\sigma$ )-strain ( $\epsilon$ ) curve for steel. Show all the salient points. Explain how do you get the value of Young's modulus ( $E$ ). 6
- (c) A specimen of steel, 20 mm diameter with a gauge length of 200 mm, was tested to failure. It undergoes an extension of 0.20 mm under a load of 60 kN. Load at elastic limit is 120 kN. The maximum load is 180 kN. The breaking load is 160 kN. Total extension is 50 mm and the diameter at fracture is 16 mm. Find (i) stress at elastic limit, (ii) Young's modulus, (iii) percentage elongation, and (iv) percentage reduction in area.  $4 \times 2$

### Group B

5. (a) State Newton's law of viscosity. 2
- (b) Define (i) ideal fluid, (ii) real fluid, (iii) Newtonian fluid, and (iv) non-Newtonian fluid.  $4 \times 1$
- (c) A flat plate of area  $1.5 \times 10^6 \text{ mm}^2$  is pulled with a speed of 0.4 m/s relative to another plate located at a distance of 0.15 mm from it. Find the force and power required to maintain this speed, if the fluid separating them is having viscosity as 1 poise. 6
- (d) A rectangular plane surface is 2 m wide and 3 m deep. It lies in a vertical plane in water. Determine the total pressure and position of centre of pressure on the plane surface when its upper edge is horizontal and (i) coincides with water surface, and (ii) 2.5 m below the free water surface.  $4 + 4$

6. (a) Define the following terms :  $4 \times 1$
- (i) Thermodynamic system
- (ii) Thermodynamic properties
- (iii) Constant volume specific heat
- (iv) Ideal gas
- (b) For a reversible adiabatic process, prove that  $pv^\gamma = \text{constant}$ , where  $\gamma = \text{ratio of specific heats}$ . Represent the process on P-V and T-s planes. 8
- (c) Air, initially at a pressure of 100 kPa and a volume of  $3.1 \text{ m}^3$ , is contained in a piston cylinder arrangement. It undergoes the following processes in a sequence to complete a cycle : (i) Adiabatic compression to a volume to  $0.18 \text{ m}^3$ , (ii) constant pressure heat addition until volume doubles, (iii) adiabatic expansion to its initial volume, and (iv) constant volume heat rejection till it reaches the initial pressure and volume. Show the cycle on P-V diagram and calculate the net work transfer during the cycle. Assume  $\gamma = 1.4$  for air. 8
7. (a) State the first law of thermodynamics for a closed system undergoing a cycle and prove that energy is a property of the system. 8
- (b) Write two statements of second law of thermodynamics. 4
- (c) Air flows steadily at the rate of 0.5 kg/s through an air compressor, entering at 7 m/s velocity, 100 kPa pressure and  $0.95 \text{ m}^3/\text{kg}$  volume, and leaving at 5 m/s, 700 kPa and  $0.19 \text{ m}^3/\text{kg}$ , respectively. The internal energy of air leaving is 90 kJ/kg greater than that of the air entering. Cooling water in the compressor jackets absorbs heat from the air at the rate of 58 kW. Determine (i) work input to the air (in kW), and (ii) ratio of inlet and outlet pipe diameters.  $4 + 4$

8. (a) Prove that air standard efficiency of ideal Otto cycle always increases with increase in compression ratio. 7
- (b) Distinguish between the principle of operation of SI and CI engines. 6
- (c) A reversible heat engine operates between two reservoirs at temperatures of 600 °C and 40 °C. The engine drives a reversible refrigerator which operates between reservoirs at temperatures of 40 °C and -20 °C. The heat transfer to the engine is 2000 kJ and the net work output of the combined engine refrigerator plant is 360 kJ. Evaluate the heat transfer to the refrigerant and the net heat transfer to the reservoir at 40 °C. 7

### Group C

9. Choose the correct answer for the following : 10 × 2
- (i) In a simple harmonic motion, the line of oscillation is given by
- (a)  $T = 2\pi/\omega$
- (b)  $T = 2\pi\omega$
- (c)  $T = 2\pi/\omega^2$
- (d)  $T = 2\omega/\pi$
- (ii) The radius of Mohr's circle for two unlike principal stresses of magnitude P is
- (a) P
- (b) P/2
- (c) P/4
- (d) None of the three above.

- (iii) Maximum bending moment occurs when
- (a) shear force is maximum.
- (b) shear force is minimum.
- (c) shear force changes sign.
- (d) deflection is zero.
- (iv) A couple can be balanced by
- (a) a force.
- (b) a moment.
- (c) a torque.
- (d) an equal and opposite couple.
- (v) Work done in a free expansion process is
- (a) zero.
- (b) minimum.
- (c) maximum.
- (d) negative.
- (vi) The centre of gravity of a hemisphere of radius,  $r$  from its base measured along vertical radius is
- (a)  $4r/3\pi$
- (b)  $3r/2$
- (c)  $3r/8$
- (d)  $4r/7$
- (vii) For a reversible adiabatic process, the change in entropy is
- (a) zero.
- (b) minimum.
- (c) maximum.
- (d) unity.

- (viii) Which one of the following is the extensive property of a thermodynamic system ?
- (a) Pressure
  - (b) Volume
  - (c) Temperature
  - (d) Density
- (ix) Viscosity of gases
- (a) decreases with the increase of temperature.
  - (b) increases with the increase of temperature.
  - (c) remains same with the increase of temperature.
  - (d) None of the three above.
- (x) Which one of the following device is used to measure velocity of a fluid in a pipe ?
- (a) Venturimeter
  - (b) Pitot tube
  - (c) Orifice meter
  - (d) Manometer



You may [download prospectus](#) to buy excellent study material for AMIE exams.

You will also get **full access to our online support** with our course which includes latest AMIE question papers, model test papers, eBooks, audio and video lectures, course updates and interactive objective questions.

## **AMIE(I) Study Circle**

**Website:** [www.amiestudycircle.com](http://www.amiestudycircle.com)

**WhatsApp:** 9412903929

**Email:** [info@amiestudycircle.com](mailto:info@amiestudycircle.com)