

W'07 : 7 AN : CV 407 (1433)

ANALYSIS AND DESIGN OF STRUCTURES

Time : Three hours

Maximum Marks : 100

*Answer FIVE questions, taking ANY TWO from Group A ,
ANY TWO from Group B and ALL from Group C .*

*All parts of a question (a, b, etc.) should
be answered at one place.*

*Answer should be brief and to-the-point and be supplemented
with neat sketches. Unnecessary long answers may
result in loss of marks.*

*Any missing or wrong data may be assumed suitably giving
proper justification.*

Figures on the right-hand side margin indicate full marks .

Use of IS 800, steel table, and IS 456 are permitted .

Group A

1. (a) Derive the relationship between load, shear force and bending moment. 5
- (b) A continuous beam *ABC* fixed at the ends is loaded as shown in *Fig. 1*. Find the reaction and support moments. Also, draw BM and SF diagrams. 15

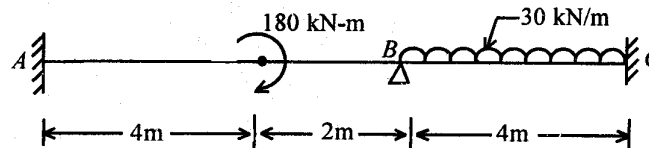

Fig. 1

2. (a) A strut, 2.5 m long, is 6 cm in diameter. One end of the strut is fixed while its other end is hinged. Find the safe compressive load for the member using Euler's formula, allowing a factor of safety of 3.5. Take $E = 2.1 \times 10^6 \text{ kg/cm}^2$. 10

- (b) Fig. 2 shows a beam of 10 m span and having an overhang of 5 m. Calculate the slope and deflection at D as well as at C. Take EI as constant. 10

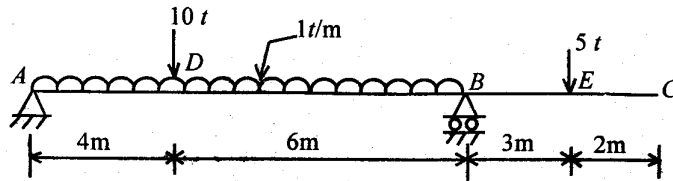

Fig. 2

3. (a) What is the difference between bending and buckling? 3
- (b) A simply-supported beam of 8 m span is carrying uniformly distributed load of 1000 kg/m over the whole span and a concentrated load of 5000 kg at mid-span of the section of the beam is circular with diameter of 150 mm. Calculate the maximum bending stress and maximum shear stress developed in the section of the beam. 17

4. (a) Define flexibility coefficient and stiffness coefficient. What is the relation between stiffness and flexibility? 5
- (b) Determine the support moments for the portal frame shown in Fig. 3. All the members have the same flexural rigidity. 15

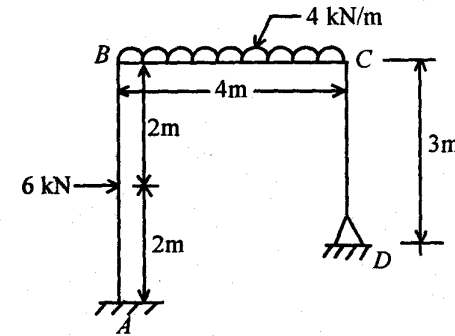

Fig. 3

Group B

5. (a) In a roof truss, a tensile member consists of an ISA 60 mm \times 60 mm \times 8 mm and is connected to a gusset plate by one leg only through 18 mm diameter rivet in one chainline along the length of the member. Determine the tensile strength of the member. Take permissible tensile stress of the material for the truss as 1500 kg/cm². 10
- (b) A member of a truss has 2.0 m effective length. It carries a compressive load of 4000 kg. Design the member as a single equal angle section for it. Given. 10

Slenderness Ratio	Permissible Stress (kg/cm ²)
140	531
150	474
160	423
170	377
180	336
190	300
200	270

6. (a) Design a suitable welded connection for a lap joint between an angle 70 mm × 70 mm × 8 mm, carrying an axial load of 10 tonnes and a gusset plate 10 mm thick. Take the permissible shear stress in the weld as 1025 kg/cm². 10
- (b) A beam of 8.0 m effective span carries a uniformly distributed load of 2000 kg/m including its own weight. Design the beam. The compression flange of the beam is held against lateral displacement. Take permissible bending stress = 1650 kg/cm², permissible shear stress = 945 kg/cm², and permissible deflection = span/325. 10
7. Design a two-way RCC slab over a room of size 5.50 m × 6.70 m, simply-supported at the edges with its corners held down. The roof of the room is approachable. Use M15 grade concrete and Fe415 steel. Draw a plan of the slab showing details of the reinforcement and also the sectional details. Use working stress method of design. 20

8. Design a RC column square in section, subjected to an axial load of 100 tonnes at working stress. Effective height of the column is 3.5 m. Percentage of reinforcement in this column should be 2%. Use M25 grade concrete and Fe415 grade steel. Also, design the isolated column footing. Take permissible bearing capacity of soil as 10 tonnes/m². Sketch the reinforcement details of column and its foundation. 20

Group C

9. Choose the *correct* answer for the following: 1 × 20
- (i) A beam simply supported at the ends has a span l . It is subjected to equal and opposite end couple M' . If EI is flexural rigidity of the beam, its central deflection is given by
- (a) $M' l^2 / 8 EI$
- (b) $M' l^2 / 6 EI$
- (c) $M' l^2 / 2 EI$
- (d) $M' l^2 / 16 EI$
- (ii) As per IS 800, the maximum deflection in a beam should not exceed
- (a) $L / 180$
- (b) $L / 250$

(c) $L/325$

(d) $L/360$

where L is the span of beam.

(iii) The maximum spacing of vertical stiffener is

(a) $1.33 d$

(b) $1.25 d$

(c) $1.50 d$

(d) $1.75 d$.

where d is the distance between flange angles.

(iv) In a steel plate girder, the curtailment of plate is based on

(a) bending moment

(b) shear force

(c) torsion

(d) axial force in the girder.

(v) The effective length for a long column, with one end fixed and the other end hinged, is given by

(a) L

(b) $2L$

(c) $L/2$

(d) $L/\sqrt{2}$

where L is the length of column.

(vi) Maximum pitch of the rivets shall not be less than

(a) $1.5 d$

(b) $2.0 d$

(c) $2.5 d$

(d) $3.0 d$

where d is the diameter of rivet hole.

(vii) At the point of contraflexure in a beam,

(a) deflection changes the sign

(b) slope is zero

(c) bending moment changes the sign

(d) bending moment is zero.

(viii) The carryover factor of a straight prismatic member with far end fixed

(a) is always equal to half ($+\frac{1}{2}$)

(b) depends on support conditions only

(c) depends on member parameters only

(d) None of the above.

(ix) The effect of arching in a beam is to

(a) reduce bending moment throughout

(b) increase bending moment throughout

- (c) increase shear force
- (d) decrease shear force.
- (x) The number of compatibility conditions needed in the analysis of a statically determinate structure is
- (a) 0
- (b) 2
- (c) 3
- (d) 6.
- (xi) Kani's method can be derived from
- (a) Money-Goldbery method
- (b) Maugh's panel method
- (c) Relaxation method
- (d) Slope deflection method.
- (xii) A steel plate is bent into a circular arc of radius 10 m. The plate section is 12 cm wide and 2 cm thick. With $E = 2 \times 10^6 \text{ kg/cm}^2$, the maximum fibre stress is given by
- (a) 1 000 kg/cm²
- (b) 2 000 kg/cm²
- (c) 3 000 kg/cm²
- (d) 4 000 kg/cm².
- (xiii) A beam of length l with equal overhangs on either sides support load W at both the free ends. The shear force between the two supports is given by
- (a) W
- (b) $2W$
- (c) $W/2$
- (d) zero.
- (xiv) A beam provided with more than two supports is called
- (a) propped cantilever
- (b) continuous beam
- (c) cantilever beam
- (d) overhang beam.
- (xv) The ratio between maximum and average shear stress for a rectangular section beam is
- (a) $3/4$
- (b) $3/2$
- (c) $4/3$
- (d) $4/5$.
- (xvi) Castigliano's theorem fall under the category of
- (a) Displacement method
- (b) Equilibrium method

(c) Force method

(d) Stiffness method.

(xvii) The live load, as recommended by IS 875 for floors in dwelling houses, is

(a) 5 kN/m²

(b) 3 kN/m²

(c) 2 kN/m²

(d) 1.5 kN/m².

(xviii) As per IS 456, the modulus of elasticity of concrete is given as

(a) $5700\sqrt{f_{ck}}$

(b) $5700 f_{ck}$

(c) $7500\sqrt{f_{ck}}$

(d) $5000\sqrt{f_{ck}}$.

where f_{ck} is the characteristic strength of concrete.

(xix) The maximum spacing of main reinforcement in a RCC slab with effective depth = 160 mm, using 12 mm diameter HYSD bars, will be

(a) 300 mm

(b) 450 mm

(c) 480 mm

(d) 800 mm.

(xx) The two-way shear in a footing has to be checked at a section

(a) $d/2$ from the edge of the column

(b) $d/2$ from the centre line of the column

(c) at the central line of the column

(d) d from the edge of the column.

where d is the effective depth of the footing.

ANALYSIS AND DESIGN OF STRUCTURES

Time : Three hours

Maximum Marks : 100

Answer FIVE questions, taking ANY TWO from Group A,
ANY TWO from Group B and ALL from Group C.

All parts of a question (a, b, etc.) should
be answered at one place.

Answer should be brief and to-the-point and be supplemented
with neat sketches. Unnecessary long answers may
result in loss of marks.

Any missing or wrong data may be assumed suitably giving
proper justification.

Figures on the right-hand side margin indicate full marks.
Design data book is not permitted to use.

Use of IS 800, IS 456 and steel tables are permitted.

Group A

1. Find the forces in the truss members shown in Fig.1. 20

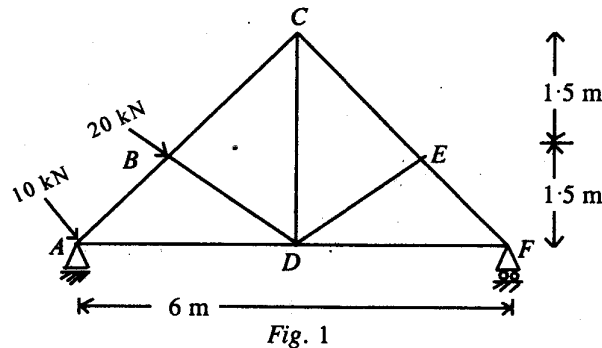

2. Calculate the deflection under the load and end slopes of a non-prismatic beam shown in Fig. 2. 20

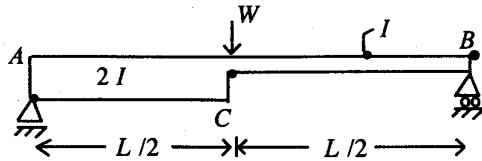
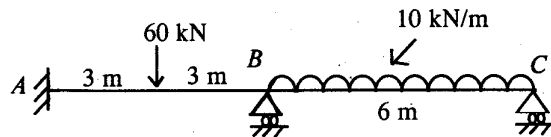

Fig. 2

3. A symmetrical three-hinged parabolic arch of 20 m span and 4 m central rise carries a point load of 40 kN at 4 m horizontally from the left-hand hinge. Calculate the normal thrust, shear force and bending moment at the load point. 20
4. Analyse the continuous beam shown in Fig. 3 and draw the SFD and BMO. Use slope deflection method. EI is constant. 20



Group B

5. (a) A tension member, carrying a load of 100 kN, is to be connected to a gusset plate. If $f_r = 150$ MPa, $f_s = 100$ MPa, $f_b = 300$ MPa, design a suitable flat to take this load and design the joint using 16 mm dia rivets. 10

- (b) Two angles, 90 mm \times 90 mm \times 8 mm, transmit a tensile force of 250 kN. The angles are connected to the gusset on either side by welding. Design the joint if size of the weld is 6 mm and allowable shear stress is 101 MPa. 10

6. (a) A simply-supported beam of 12 m span is made up of I-section ISMB 500 @ 869 N/m with two plates, each of size 250 mm \times 12 mm, attached to both flanges of the beam. Calculate the maximum uniformly distributed load the beam can carry if the compression flange is fully restrained. Assume permissible bending stress as 165 MPa. 14
- (b) Design a suitable rolled steel section for the column to carry a load of 400 kN. The height of the column is 5 m. Take the ends unrestrained in direction only. 6
7. Design a two-way slab for a room of size 4 m \times 5 m with discontinuous and simply-supported edges in all the sides with corners prevented from lifting to support a live load of 4 kN/m². Adopt M20 grade concrete and Fe 415 steel. 20
8. Design a reinforced concrete column of 400 mm \times 600 mm size subjected to an axial working load of 2000 kN. The column has an unsupported length of 3.0 m as is supported against side sway in both directions. Use M20 grade concrete and Fe 415 steel. 20

Group C

9. Answer the following in brief : 2 x 10

- (i) How will you determine the stability and determinacy of structures ?
- (ii) State three moment equations.
- (iii) State Castigliano's theorem.
- (iv) Draw the influence diagram for shear force at 3 m from left support of a simply supported beam of 10 m span.
- (v) Differentiate between force and stiffness methods.
- (vi) Define the 'distribution factor' and 'carry over'.
- (vii) What are the classifications of rivets and riveted joints.
- (viii) Differentiate between limit state and working stress design of reinforced concrete structures.
- (ix) What is a gantry girder ?
- (x) Enumerate the principle of footing design.

W'09:7AN:CV407 (1433)

ANALYSIS AND DESIGN OF STRUCTURES

Time : Three hours

Maximum Marks : 100

*Answer FIVE questions, taking ANY TWO from Group A,
ANY TWO from Group B and ALL from Group C.*

*All parts of a question (a,b,etc.) should
be answered at one place.*

*Answer should be brief and to-the-point and be supplemented
with neat sketches. Unnecessary long answers may
result in loss of marks.*

*Any missing or wrong data may be assumed suitably giving
proper justification.*

Figures on the right-hand side margin indicate full marks.

*Design data book is not permitted to use. Use of IS 800,
IS 456 and steel tables are permitted.*

Group A

1. A symmetrical three-hinged circular arch has a span of 16 m and a rise to the central hinge of 4 m. It carries a vertical downward load of 160 kN at 4 m from the left end. Find the (a) magnitude of the horizontal thrust at the springings, (b) reactions at the supports, (c) bending moment of 6 m from left-hand hinge, and (d) maximum positive and negative bending moments. 20

2. Find the deflection of the simply-supported beam as shown in Fig. 1 by any method. Also, find the maximum deflection. Given : $E = 2 \times 10^5 \text{ N/mm}^2$, $I = 15 \times 10^5 \text{ m}^4$. 20

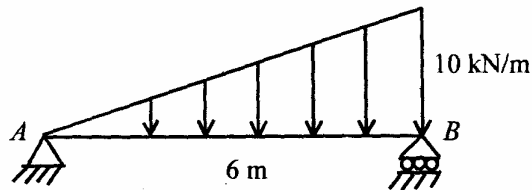

Fig. 1

3. The following system of wheel load crosses a simply-supported span of 25m. The series of wheel loads are shown in Fig. 2. Find the maximum bending moment and maximum SF in the span. Also, find the maximum bending moment at 10 m from left end. 20

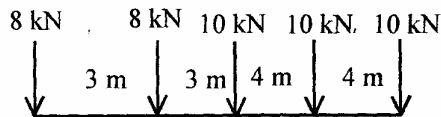

Fig. 2

4. Analyse the continuous beam ABCD as shown in Fig. 3 by moment distribution method and draw bending moment diagram. 20

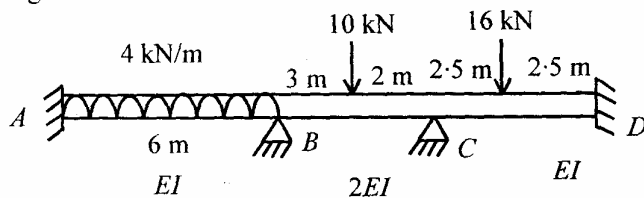

Fig. 3

Group B

5. (a) A welded crane bracket supports a load of 120 kN at a distance of 150 mm from the edge of a column ISWB 300. Using 15 mm thick plate, design the connection. 10
- (b) Design a steel column to carry an axial load of 2000 kN. The length of the column is 5 m and effectively held in both ends. 10
6. An office building $18 \text{ m} \times 36 \text{ m}$ in plan is made of secondary and main beams. The secondary beams are spaced at 3 m c/c, span over 6 m and support on RC slab of 10 cm thick. The span of main beam is 9 m. If the live load is 2 kN/m^2 , design the main beam. 20
7. Design a gantry girder to carry an overhead crane for an industry for the following data : 20
- | | |
|------------------------|------------|
| Crane lifting capacity | = 200 kN |
| Weight of crane | = 150 kN |
| Weight of trolley | = 75 kN |
| Centre of girder | = 20 m |
| Approach of crane hook | = 1.2 m |
| Span of gantry girder | = 6 m |
| Weight of rail | = 0.3 kN/m |
| Height of rail | = 75 mm |
8. Design a reinforced concrete rectangular beam for a simply-supported span of 5 m and carrying a superimposed load of 20 kN/m inclusive of self-weight of beam. Use M 20 concrete and Fe 415 bars. The width of beam = 300 mm. 20

Group C

9. Answer the following in brief : 2 × 10

- (i) How will you find the static indeterminacy of a pin jointed two-dimensional and three-dimensional frames ?
- (ii) Write the equilibrium equations adopted for method of joints and method of sections.
- (iii) State Castigliano's theorems.
- (iv) Differentiate between cables and arches.
- (v) Write the slope deflection equation of a beam AB with span ' l ' and constant EI .
- (vi) What are different types of welds used for structural connections ?
- (vii) Design a tension member to carry an axial force of 40 kN.
- (viii) Explain the calculation of self-weight and live load on roof trusses.
- (ix) Write the formula to find the thickness of base plate in column base.
- (x) Write any *four* assumptions made in the analysis of a beam by working stress design of a RC member.

S'10:7AN:CV 407 (1433)

ANALYSIS AND DESIGN OF STRUCTURES

Time : Three hours

Maximum Marks : 100

*Answer FIVE questions, taking ANY TWO from Group A,
ANY TWO from Group B and ALL from Group C.*

*All parts of a question (a,b,etc.) should
be answered at one place.*

*Answer should be brief and to-the-point and be supplemented
with neat sketches. Unnecessary long answers may
result in loss of marks.*

*Any missing or wrong data may be assumed suitably giving
proper justification.*

Figures on the right-hand side margin indicate full marks.

*Design data handbook is not permitted to use. Use of IS 800,
IS 456 and steel tables are permitted.*

Group A

1. Analyse the moment distribution method and draw shear force and bending moment diagram : 20

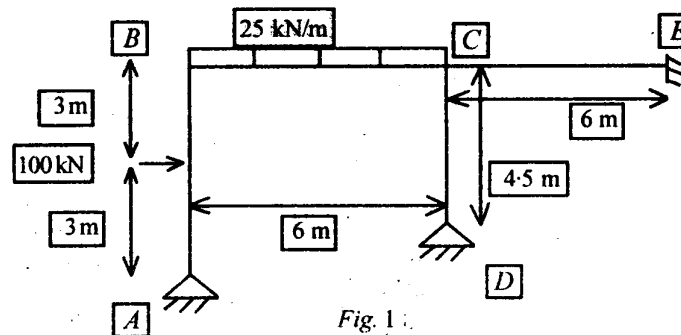

2. Find out δ_{D_v} and δC_h for the frame shown in Fig. 2 : 20

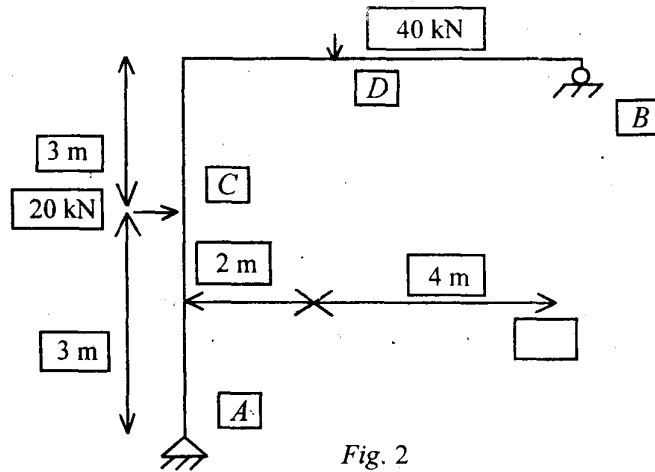

Fig. 2

3. A Warren girder of 60 m span is built up of equilateral triangles and has 10 panels of 6 m each. Draw an influence line for force for the left-hand diagonal in the fourth panel from the left-hand support. State the exact position of a single rolling load in the panel so that the force in the diagonal is zero. 20
4. A three-hinged circular arch has a span of 50 m and a rise of 10 m. A load of 200 kN crosses the arch from left to right. Determine the (i) maximum horizontal thrust, and (ii) maximum bending moment, positive and negative, at a section 15 m from the left-hand hinge. 20

Group B

5. Design a welded plate girder consisting of only plates for the following : Effective span 12 m, UDL 25 kN/m, three concentrated loads moving on the span, each 120 kN and spaced at 3 m apart. Draw neat sketches. 20

S'10:7AN:CV 407 (1433) (2)

(Continued)

6. Crane loads on a gantry girder and other data are : Crane capacity $W_k = 100$ kN, crane girder weight, $W_c = 80$ kN, wheel spacing, $a = 3.5$ m, weight of crab, $W_r = 10$ kN, column spacing = gantry span = 600 mm, minimum edge distance of crane, $g = 1000$ mm. Design a channel section which can be placed at the level of the top flange and give a lateral support to the girder. 20
7. A doubly reinforced rectangular beam is 300 mm wide and 450 mm deep and is subjected to a bending moment of 90 kN-m. If the limiting stresses in concrete and steel are 5 N/mm² and 140 N/mm², determine area of steel rebars. Assume $m = 18$. 20
8. Design a combined footing for two RC columns, A and B, separated by a distance of 4 m c/c : Column A is 500 mm² and carries a load of 1200 kN, whereas column B is 600 mm² and carries a load of 1600 kN. The safe bearing capacity of soil is 200 kN/m². Use M 20 grade concrete and Fe 415 grade of steel. 20

Group C

9. Answer the following in brief: 2 × 10
- Method of section for plane truss
 - Virtual work method for deflection of truss
 - Moment area method
 - Conjugate beam method
 - Kani's method

S'10:7AN:CV 407 (1433) (3)

(Turn Over)

- (vi) Three moment equation
- (vii) Structural fasteners
- (viii) Considerations for fire in RCC design
- (ix) Eccentric connections
- (x) Development length.

ANALYSIS AND DESIGN OF STRUCTURES

Time : Three hours

Maximum Marks : 100

Answer FIVE questions, taking ANY TWO from Group A,
ANY TWO from Group B and ALL from Group C.

All parts of a question (a, b, etc.) should
be answered at one place.

Answer should be brief and to-the-point and be supplemented
with neat sketches. Unnecessary long answers may
result in loss of marks.

Any missing or wrong data may be assumed suitably giving
proper justification.

Figures on the right-hand side margin indicate full marks.

Group A

1. Find the vertical and horizontal deflection of the end *A*
of the member *ABCD* shown in Fig. 1. Take
 $E = 210 \text{ kN/mm}^2$. 20

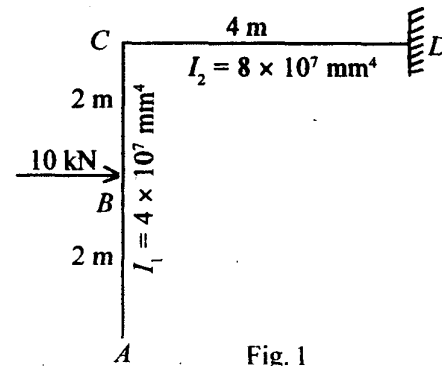

Fig. 1

2. A three-hinged segmental arch ACB has a span of 30 m and a rise of 5 m. It supports a concentrated load of 150 kN at a section 7.5 m from the left support. Find the reactions at the support and maximum positive and negative bending moments. 20
3. A continuous beam ABC fixed at the ends is loaded as shown in Fig. 2. Find the reactions and support moments. Also, draw shear force and bending moment diagrams. Use the moment distribution method. 20

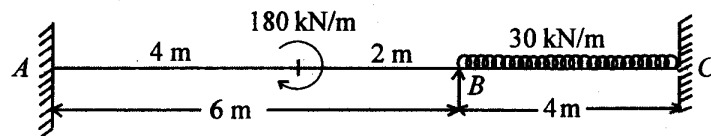

Fig. 2

4. A cantilever truss of Warren-type is loaded as shown in Fig. 3. Determine stresses in the members of the truss. 20

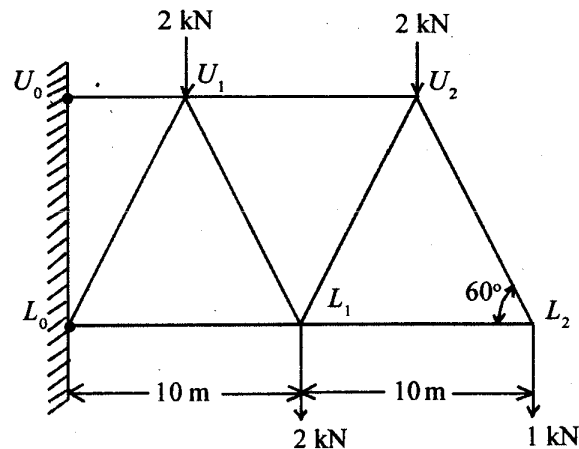

Fig. 3

S'11:7AN:CV407(1433)

(2)

(Continued)

Group B

5. Design a built up battened column to carry an axial load of 2450 kN. Length of column is 4.85 m. It is effectively held in position at the ends but restrained against rotation at one end only. Take $f_y = 250 \text{ N/mm}^2$. Also, design the battens. 20
6. (a) A tension member of a roof truss consists of single angle ISA 150 mm \times 115 mm \times 8 mm. It carries a tension of 180 kN. Find the length of 6 mm weld at extremities of the longer leg for its connection to gusset. 10
- (b) Design a single angle discontinuous strut to carry a load of 90 kN. The length of strut is 3 m. The strut is connected by one rivet at each end. 10
7. Design a doubly reinforced beam to carry a superimposed load of 60 kN/m run. The overall depth and width of the beam are restricted to 840 mm and 300 mm, respectively. The beam has a clear span of 5 m and a bearing of 50 cm on each end. Use M20 concrete and Fe 415 steel. 20
8. A square column of size 350 mm \times 350 mm carries a load of 1000 kN. Design a square footing to support the column. The S.B.C. of the soil is 100 kN/m². Use M20 grade concrete and HYSD steel of grade Fe 415. 20

Group C

9. Answer the following: 10 \times 2
- (i) State three moment equation.
- (ii) State relation between shear force and bending moment.

S'11:7AN:CV407(1433)

(3)

(Turn Over)

- (iii) Classify types of rivets.
- (iv) Compare lacing and battens.
- (v) Write steps for design of gantry girder.
- (vi) Explain law of virtual failure.
- (vii) Describe method of consistent deformation.
- (viii) Explain method of conjugate beam.
- (ix) State Eddy's theorem and explain its application to arches.
- (x) Define influence line and explain its application in analysis of structures.

W'12:7AN:CV 407 (1433)

ANALYSIS AND DESIGN OF STRUCTURES

Time : Three hours

Maximum Marks : 100

Answer FIVE questions, taking ANY TWO from Group A, ANY TWO from Group B and ALL from Group C.

All parts of a question (a, b, etc.) should be answered at one place.

Answer should be brief and to-the-point and be supplemented with neat sketches. Unnecessary long answers may result in loss of marks.

Any missing or wrong data may be assumed suitably giving proper justification.

Figures on the right-hand side margin indicate full marks.

Group A

1. Analyse the continuous beam shown in Fig.1 by moment distribution method. Sketch bending moment and shear force diagrams. 20

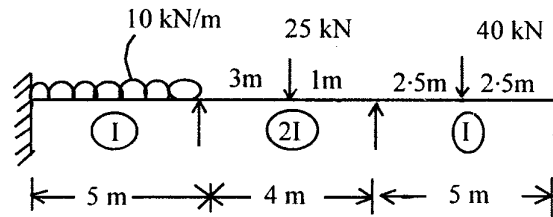

Fig. 1

2. Analyse the structure shown in Fig. 2 by the stiffness method: 20

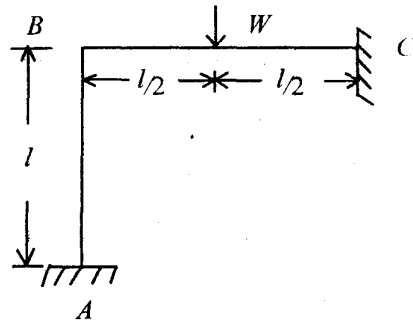

Fig. 2

3. A truss of 15 m span is loaded as shown in Fig. 3. Find the forces in the members of the truss by the method of joints. 20

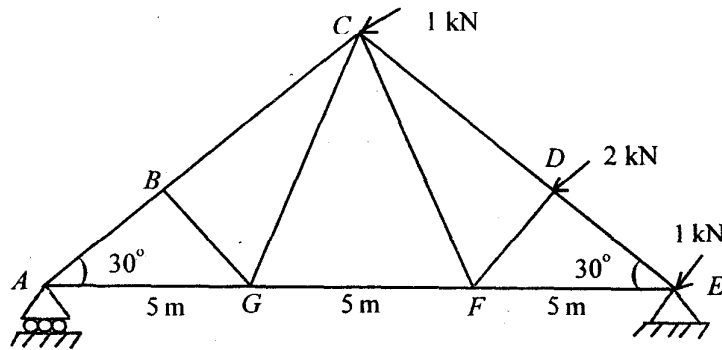

Fig. 3

4. A fixed beam of 6 m span is loaded with point loads of 150 kN at distance 2 m from each support. Draw the bending moment and shear force diagrams. Also, find the maximum deflection. Take $E = 2 \times 10^5 \text{ N/mm}^2$. 20

Group B

5. An unequal angle, 1.5 m long, of a truss is connected to the gusset plate. It carries ultimate tension of 230 kN. Design the section using bolted connection. Assume $f_y = 250 \text{ MPa}$ and $f_u = 410 \text{ MPa}$. 20
6. Design a built-up column carrying a factored axial load of 1800 kN. The length of the column is 8 m. It is effectively held in position at both ends and restrained against rotation at one end. Use steel Fe 410 with $f_y = 250 \text{ MPa}$. 20
7. Design a welded plate girder for an effective span of 30 m and carrying a uniformly distributed load of 30 kN/m and two concentrated loads of 150 kN each acting at 10 m from both ends. The girder is simply-supported at ends. It is fully restrained at both ends against lateral buckling throughout the span. Given : Load factor = 1.5 and yield stress of steel, $f_y = 250 \text{ MPa}$. 20
8. Design a RC rectangular beam for a simply-supported span of 5 m and carrying a superimposed load of 20 kN/m inclusive of self-weight of the beam. Use M 20 concrete and Fe 415 bars. Take width of the beam = 300 mm. 20

Group C

9. Answer the following in brief : 10 × 2
- What is point of contraflexure ?
 - What is the maximum deflection of a simply-supported beam carrying udl ?
 - Give examples for statically indeterminate structures.
 - Give Euler's formula for columns when (i) both ends hinged, and (ii) both ends fixed.

- (v) What is rotation factor in Kani's method ?
- (vi) List *any two* advantages and two disadvantages of welded joints.
- (vii) What are the possible modes of failures in compression members ?
- (viii) What should be the minimum shear reinforcement in RC sections ?
- (ix) What should be the minimum cover for RC beams and columns ?
- (x) When are bracings required in industrial buildings ?

S'12:7AN:CV407 (1433)

ANALYSIS AND DESIGN OF STRUCTURES

Time : Three hours

Maximum Marks : 100

*Answer FIVE questions, taking ANY TWO from Group A,
ANY TWO from Group B and ALL from Group C.*

*All parts of a question (a, b, etc.) should
be answered at one place.*

*Answer should be brief and to-the-point and be supplemented
with neat sketches. Unnecessary long answers may
result in loss of marks.*

*Any missing or wrong data may be assumed suitably giving
proper justification.*

Figures on the right-hand side margin indicate full marks.

Group A

1. Using moment distribution method, analyse the portal frame shown in Fig. 1 : 20

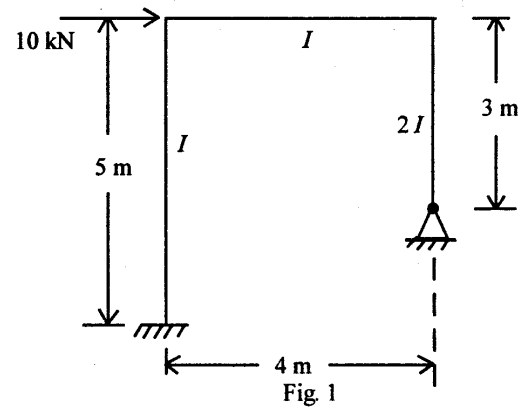

(Turn Over)

2. (a) For a two hinged parabolic arch (Fig. 2), moment of inertia of the section varies as secant of the slope. Determine (i) reactions at the supports; (ii) normal thrust and radial shear at section D ; and (iii) bending moment at C .

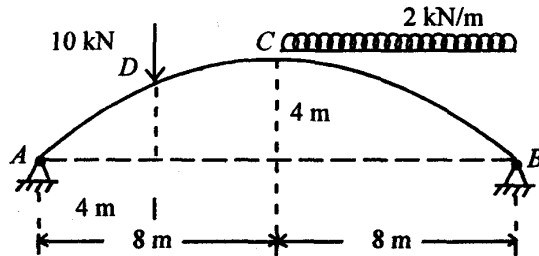

Fig. 2

- (b) Derive the general expression of the horizontal thrust in a parabolic two-hinged arch due to a rise of temperature $\theta^\circ\text{C}$. Coefficient of linear expansion α per $^\circ\text{C}$. Moment of inertia varies as the secant of slope of the rib axis.
3. Draw the influence lines for forces in the members U_2U_3 , U_2L_3 and L_2L_3 of a truss (Fig. 3). If a line load of 8 kN/m traverses from L_1 to L_5 , find the value of maximum forces in these members.

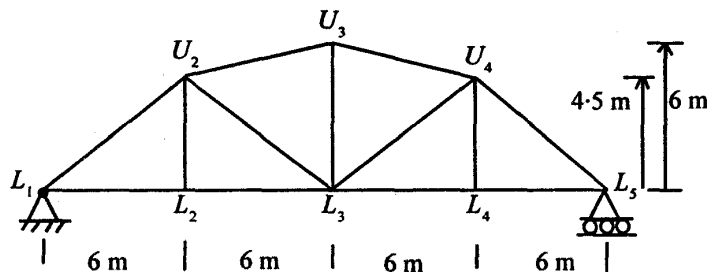

Fig. 3

4. (a) A beam AB of length l is fixed at both the ends. It carries a distributed load varying linearly from zero at left end to w at the right end. Calculate the fixed end moments.

- (b) A beam AB of span 6 m is fixed at A and simply supported at B. It carries two concentrated loads 150 kN and 90 kN at C and D distant 1.5 m and 4.5 m from the fixed end A. Draw the bending moment diagram.

Group B

5. (a) Design a seated connection for a beam ISLB 275 @ 324 N/m supported on the web of a column ISHB 250 @ 500 N/m. End reaction of the beam is 100 kN.

- (b) An I-section purlin has to be provided for a roof with an effective span of 12 m. The principal rafters are placed 3.6 m c/c. Spacing of purlins is 1.8 m. Pitch of the roof is 30° , weight of roofing material is 200 N/m^2 , and normal wind pressure is 1.2 kN/m^2 . Design a suitable section of purlin.

6. Design a suitable lacing for a composite column consisting two ISLC 350 with the back-to-back spacing of 220 mm. The flanges of channels are 100 mm. The rivets are to be attached at 60 mm from the web. Slenderness ratio of the column is $\lambda = 40$. Size of rivets has to be 20 mm.

7. The cross-section of a singly reinforced simply-supported beam is $500\text{ mm} \times 800\text{ mm}$. Reinforcement consists of 5 bars of 20 mm diameter. Determine the maximum stress in concrete when steel is stressed to 200 N/mm^2 . M20 concrete and Fe415 steel are used. Also, determine the load it can carry for an effective span of 6 m.

8. (a) A reinforced concrete slab $20\text{ m} \times 4\text{ m}$ in plan has to carry 6 kN/m^2 , inclusive of its own weight. Determine (i) effective depth of slab, and (ii) reinforcement. M20 concrete and Fe 415 steel are to be used. 10
- (b) Design a short circular column to carry an axial load of 1500 kN using M20 concrete and Fe 415 steel. 10

Group C

9. Answer the following in brief : 10 × 2
- (i) What is the relative stiffness of members as required for moment distribution method.
- (ii) Distinguish between lacing and batten for composite columns.
- (iii) Write salient features of Kani's method.
- (iv) Compare the Euler's concept and Rankine concept for analysis of a column.
- (v) Give the degree of internal indeterminacy and external indeterminacy of a plane truss.

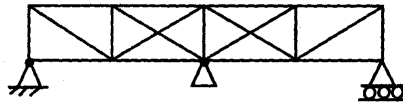

- (vi) Write the Castigliano's first strain energy theorem.
- (vii) Differentiate between a riveted connection and a welded connection of steel plates.
- (viii) Explain the concept of splicing a plate girder.
- (ix) Explain the term 'bond length of reinforcement bar.'
- (x) What are the functions of providing 2-legged stirrups in beam ?

ANALYSIS AND DESIGN OF STRUCTURES

Time : Three hours

Maximum Marks : 100

Answer FIVE questions, taking ANY TWO from Group A,
ANY TWO from Group B and ALL from Group C.

All parts of a question (a,b,etc.) should
be answered at one place.

Answer should be brief and to-the-point and be supplemented
with neat sketches. Unnecessary long answers may
result in loss of marks.

Any missing or wrong data may be assumed suitably giving
proper justification.

Figures on the right-hand side margin indicate full marks.

Group A

1. (a) Determine the degree of external static indeterminacy
of the beams as shown in Figs. 1 and 2 for the general
case loading ? 5

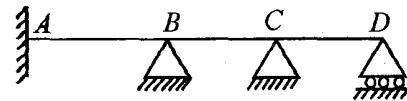

Fig. 1

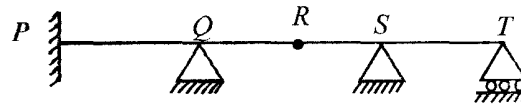

Fig. 2

- (b) Draw the bending moment and shear force diagrams for the beam loaded as shown in Fig. 3. Also, determine the maximum bending moment and the point at which it occurs? 15

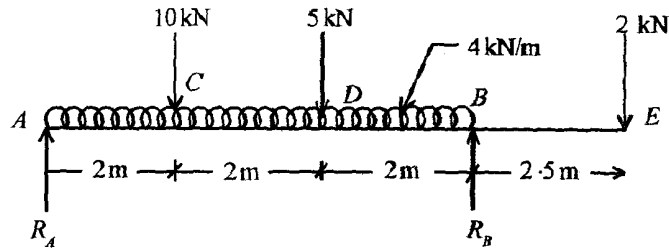

Fig. 3

2. A beam PQRS of the uniform cross-section is loaded as shown in Fig. 4. Determine (i) slope at point R, (ii) slope at point P, and (iii) deflection at point S. Use conjugate beam method. Given : $E = 200 \times 10^6 \text{ kN/m}^2$; $I = 120 \times 10^{-6} \text{ m}^4$. 20

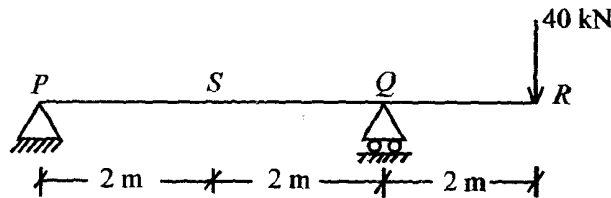

Fig. 4

3. (a) Briefly explain the statement of Castigliano's theorem? Also, explain its uses. 5

- (b) A truss of 6 m span is loaded as shown in Fig. 5. Determine the forces in the members AB, BC, AG, DE, EF and BG of the truss using method of joints. 15

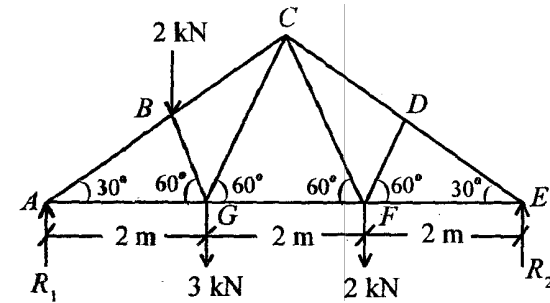

Fig. 5

4. A horizontal beam ABCD is loaded as shown in Fig. 6. The beam ABCD is supported on hinged supports and the beam is continuous over three equal spans each of 3 m. All the supports are initially at the same level. Plot the bending moment diagram of the beam, if support A settles by 15 mm, support B settles by 40 mm and support C settles by 30 mm. Given : $E = 2 \times 10^5 \text{ N/mm}^2$, $I = 2.4 \times 10^6 \text{ mm}^4$. 20

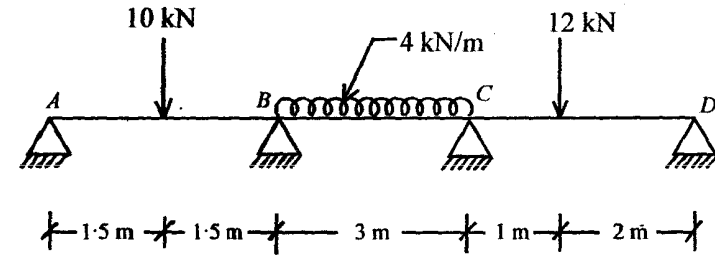

Fig. 6

Group B

5. (a) Briefly explain the fillet and butt welds. 5
- (b) Two angle irons, 8 mm thick, placed back-to-back and carries a direct load of 12 ton is connected to a gusset plate of 10 mm thick placed in between the two connected legs. Determine the number of power-driven

field rivet 16 mm dia required for the joint ? Assume shearing stress, $F_s = 945 \text{ kg/cm}^2$ and bearing stress, $F_{br} = 2125 \text{ kg/cm}^2$.

5

- (c) A 300 ISF 10 mm of grade Fe 410 is used as a tension member and connected to a 12 mm gusset plate by 20 mm dia bolts. Determine the effective net area of the member, if (i) chain bolting is done as shown in Fig. 7(a), and (ii) zig-zag bolting is done as shown in Fig. 7(b).

5 + 5

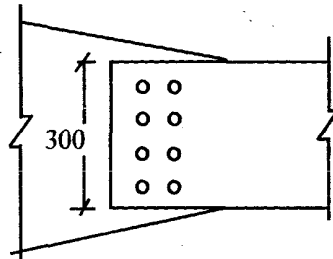

Fig. 7(a)

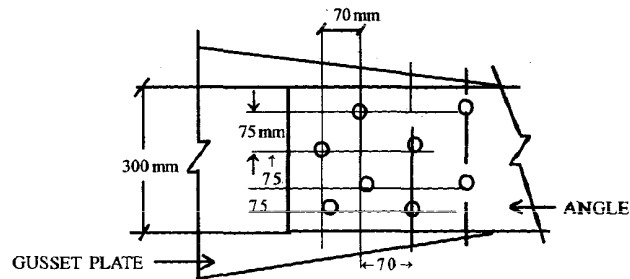

Fig. 7(b)

Assume at least two rivets for the joints. Assume allowable stress in axial compression by referring Table I.

10

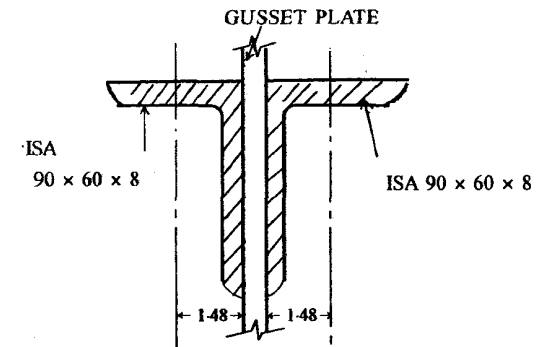

Fig. 8

Table 1 : Allowable stress in axial compression

l/r Ratio	Allowable Stress, kg/cm^2
50	1172
60	1130
70	1075
80	1007
90	928

- (b) A beam of 7.0 m effective span carries a uniformly distributed load of 1900 kg/m, including self-weight. The compression flange is held against lateral displacement. Assume allowable bending stress = 1650 kg/cm^2 , allowable shearing stress = 945 kg/cm^2 . Check the suitability of beam section ISLB 350 @ 49.5 kg/m for the above beam.

10

7. (a) Briefly explain the procedure to design the plate girder ?

10

(b) Briefly explain the following : 2 + 2 + 3 + 3

- (i) Load combinations to be considered in design of roof trusses
- (ii) Slenderness ratio in compression members
- (iii) Web crippling and web buckling
- (iv) Short column, intermediate column, and long column.

(a) Design the suitable slab base for a column having one ISHB 300 @ 63 kg/m and two cover plates of 350 mm x 25 mm as shown in Fig. 9. The column carries an axial load of 240 ton. Assume the permissible bearing stress for slab base = 1890 kg/cm². 10

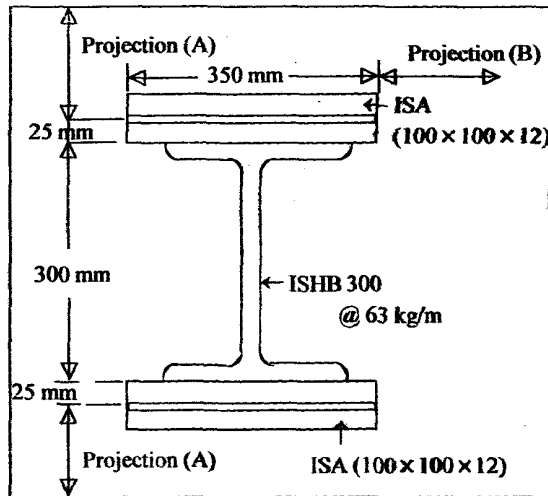

Fig. 9

(b) A RCC beam is 30 cm wide and 70 cm deep. The centres of steel are 5 cm from the respective edges. Determine the area of steel in compression and tension zone for a bending moment of 1,300,000 kg.cm.

Assume the limiting stress in concrete and steel are 50 kg/cm² and 1400 kg/cm², respectively. Given : Modular ratio (m) = 18. Note that RCC beam is reinforced on both sides.

10

Group C

9. Answer the following in brief : 10 x 2

- (i) Define 'statically indeterminate structure' and degree of indeterminacy.
- (ii) Briefly explain the terms 'lap joint' and 'butt joint'.
- (iii) What do you mean by influence line ?
- (iv) Briefly explain the 'perfect frame' and 'imperfect frame'.
- (v) Briefly explain the purpose of stiffeners in steel structures.
- (vi) What are the advantages of the bolted connection over riveted connection ?
- (vii) Briefly explain the efficiency of a joint in the steel structure.
- (viii) Sketch four important types of rolled steel structure shapes and label its various parts.
- (ix) What do you mean by 'three hinged arches' ?
- (x) Differentiate between under-reinforced and over-reinforced sections for a RCC beam.