

1. Choose the most appropriate phrase from the options given below to complete the following sentence.

The aircraft _____ take off as soon as its flight plan was filed.

- A. is allowed to
- B. will be allowed to
- C. was allowed to
- D. has been allowed to

2. Read the statements:

All women are entrepreneurs.

Some women are doctors

Which of the following conclusions can be logically inferred from the above statements?

- A. All women are doctors
- B. All doctors are entrepreneurs
- C. All entrepreneurs are women
- D. Some entrepreneurs are doctors

3. Choose the most appropriate word from the options given below to complete the following sentence.

Many ancient cultures attributed disease to supernatural causes. However, modern science has largely helped _____ such notions.

- A. impel
- B. dispel
- C. propel
- D. repel

4. The statistics of runs scored in a series by four batsmen are provided in the following table, Who is the most consistent batsman of these four?

Batsman	Average	Standard deviation
K	31.2	5.21
L	46.0	6.35
M	54.4	6.22
N	17.9	5.90

- A. K
- B. L
- C. M
- D. N

5. What is the next number in the series?

12 35 81 173 357 _____

- A. 625
- B. 725
- C. 825
- D. 925

Q. No. 6 – 10 Carry One Mark Each

6. Find the odd one from the following group:

W, E, K, O, I Q, W, A F, N, T, X N, V, B, D

- A. W, E, K, O
- B. I, Q, W, A
- C. F, N, T, X
- D. N, V, B, D

7. For submitting tax returns, all resident males with annual income below Rs 10 lakh should fill up Form P and all resident females with income below Rs 8 lakh should fill up Form All people with incomes above Rs 10 lakh should fill up Form R, except non residents with income above Rs 15 lakhs, who should fill up Form S. All others

should fill Form T. An example of a person who should fill Form T is

- A. a resident male with annual income Rs 9 lakh
- B. a resident female with annual income Rs 9 lakh
- C. a non-resident male with annual income Rs 16 lakh
- D. a non-resident female with annual income Rs 16 lakh

8. A train that is 280 metres long, travelling at a uniform speed, crosses a platform in 60 seconds and passes a man standing on the platform in 20 seconds. What is the length of the platform in metres?

- A. 440
- B. 480
- C. 520
- D. 560

9. The exports and imports (in crores of Rs.) of a country from 2000 to 2007 are given in the following bar chart. If the trade deficit is defined as excess of imports over exports, in which year is the trade deficit 1/5th of the exports?

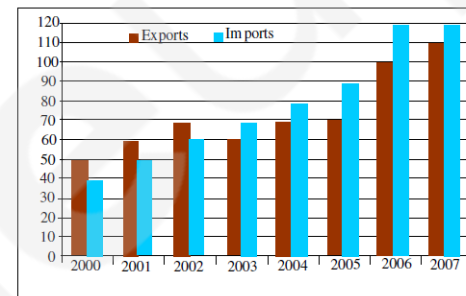

- A. 2005
- B. 2004
- C. 2007
- D. 2006

10. You are given three coins: one has heads on both faces, the second has tails on both faces, and the third has a head on one face and a tail on the other. You choose a coin at random and toss it, and it comes up heads. The probability that the other face is tails is

- A. 1/4
- B. 1/3
- C. 1/2
- D. 2/3

Q. No. 1 – 25 Carry One Mark Each

11. For matrices of same dimension M, N and scalar c, which one of these properties DOES NOT ALWAYS hold?

- A. $(M^T)^T = M$
- B. $(cM^T)^T = c(M)^T$
- C. $(M + N)^T = M^T + N^T$
- D. $MN = NM$

12. In a housing society, half of the families have a single child per family, while the remaining half have two children per family. The probability that a child picked at random, has a sibling is _____

- A. 0.42
- B. 0.52
- C. 0.62
- D. 0.67

13. C is a closed path in the z-plane given by $|z|=3$. The

$$\oint_C \left(\frac{z^2 - z + 4j}{z + 2j} \right) dz$$

value of the integral

- A. $-4\pi(1 + j2)$
- B. $4\pi(3 - j2)$
- C. $-4\pi(3 + j2)$
- D. $4\pi(1 - j2)$

14. A real (4×4) matrix A satisfies the equation $A^2 = I$, where I is the (4×4) identity matrix. The positive eigen value of A is _____.

- A. 1
- B. 2
- C. 4
- D. 8

15. Let X_1, X_2 , and X_3 be independent and identically distributed random variables with the uniform distribution on $[0, 1]$. The probability $P\{X_1 \text{ is the largest}\}$ is

- A. 0.22-0.24
- B. 0.26- 0.28
- C. 0.30 - 0.32
- D. 0.32- 0.34

16. For maximum power transfer between two cascaded sections of an electrical network, the relationship between the output impedance Z_1 of the first section to the input impedance Z_2 of the second section is

- A. $Z_2 = Z_1$
- B. $Z_2 = -Z_1$
- C. $Z_2 = Z_1^*$
- D. $Z_2 = -Z_1^*$

17. Consider the configuration shown in the figure which is a portion of a larger electrical network

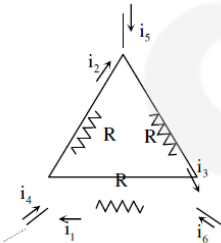

For $R = 1\Omega$ and currents $i_1 = 2A, i_4 = -1A, i_5 = 4A$, which one of the following is TRUE?

- A. $i_6 = 5A$
- B. $i_3 = -4A$
- C. Data is sufficient to conclude that the supposed currents are impossible
- D. Data is insufficient to identify the current i_2, i_3 , and i_6

18. When the optical power incident on a photodiode is $10\mu W$ and the responsivity is $0.8A/W$, the photocurrent generated (in μA) is _____.

- A. $2\mu A$
- B. $4\mu A$
- C. $6\mu A$
- D. $8\mu A$

19. In the figure, assume that the forward voltage drops of the PN diode D_1 and Schottky diode D_2 are $0.7V$ and $0.3V$, respectively. If ON denotes conducting state of the diode and OFF denotes non-conducting state of the diode, then in the circuit,

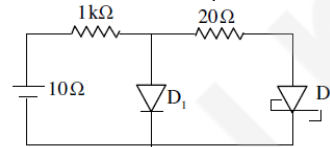

- A. both D_1 and D_2 are ON
- B. D_1 is ON and D_2 is OFF
- C. both D_1 and D_2 are OFF
- D. D_1 is OFF and D_2 is ON

20. If fixed positive charges are present in the gate oxide of an n-channel enhancement type MOSFET, it will lead to

- A. a decrease in the threshold voltage
- B. channel length modulation
- C. an increase in substrate leakage current
- D. an increase in accumulation capacitance

21. A good current buffer has

- A. low input impedance and low output impedance
- B. low input impedance and high output impedance
- C. high input impedance and low output impedance
- D. high input impedance and high output impedance

22. In the ac equivalent circuit shown in the figure, if i_{in} is the input current and R_F is very large, the type of feedback is

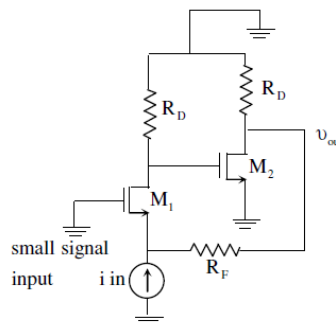

- A. voltage-voltage feedback
- B. voltage-current feedback
- C. current-voltage feedback
- D. current-current feedback

23. In the low-pass filter shown in the figure, for a cut-off frequency of $5kHz$, the value of R_2 (in $k\Omega$) is _____.

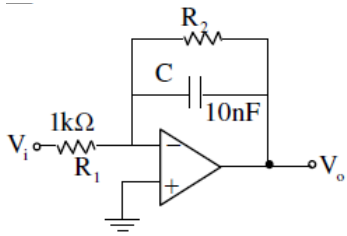

- A. 2.24
- B. 2.82
- C. 3.18
- D. 3.42

24. In the following circuit employing pass transistor logic, all NMOS transistors are identical with a threshold voltage of 1 V. Ignoring the body-effect, the output voltages at P, Q and R are,

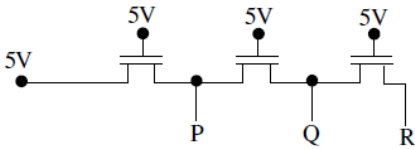

- A. 4 V, 3 V, 2 V
- B. 5 V, 5 V, 5 V
- C. 4 V, 4 V, 4 V
- D. 5 V, 4 V, 3 V

25. The Boolean expression $(X + Y)(X + \overline{Y})(\overline{X + Y}) + \overline{\overline{X}}$ simplifies to

- A. X
- B. Y
- C. XY
- D. X + Y

26. Five JK flip-flops are cascaded to form the circuit shown in Figure. Clock pulses at a frequency of 1 MHz are applied as shown. The frequency (in kHz) of the waveform at Q3 is _____.

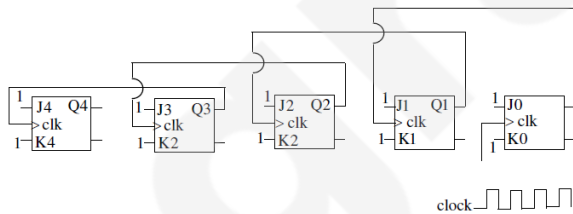

- A. 52.5
- B. 54.5
- C. 62.5
- D. 64.5

27. A discrete-time signal $x[n] = \sin(\pi^2 n)$, n being an integer, is

- A. periodic with period π .
- B. periodic with period π^2 .
- C. periodic with period $\pi/2$.
- D. not periodic

28. Consider two real valued signals, $x(t)$ band-limited to $[-500 \text{ Hz}, 500\text{Hz}]$ and $y(t)$ bandlimited to $[-1\text{kHz},$

$1\text{kHz}]$. For $z(t) = x(t) \cdot y(t)$, the Nyquist sampling frequency (in kHz) is _____

- A. 2
- B. 3
- C. 4
- D. 6

29. A continuous, linear time-invariant filter has an impulse response $h(t)$ described by

$$h(t) = \begin{cases} 3 & \text{for } 0 \leq t \leq 3 \\ 0 & \text{otherwise} \end{cases}$$

When a constant input of value 5 is applied to this filter, the steady state output is _____.

- A. 35
- B. 40
- C. 45
- D. 50

30. The forward path transfer function of a unity negative feedback system is given by

$$G(s) = \frac{K}{(s+2)(s-1)}$$

The value of K which will place both the poles of the closed-loop system at the same location, is _____.

- A. 2.25
- B. 2.50
- C. 2.75
- D. 3.15

31. Consider the feedback system shown in the figure. The Nyquist plot of $G(s)$ is also shown.

Which one of the following conclusions is correct?

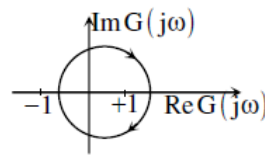
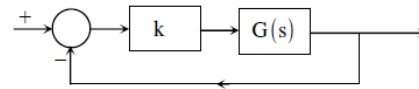

- A. $G(s)$ is an all-pass filter
- B. $G(s)$ is a strictly proper transfer function
- C. $G(s)$ is a stable and minimum-phase transfer function
- D. The closed-loop system is unstable for sufficiently large and positive k

32. In a code-division multiple access (CDMA) system with $N = 8$ chips, the maximum number of users who can be assigned mutually orthogonal signature sequences is _____

- A. 6.54-6.56
- B. 6.99- 7.01
- C. 7.54-7.56
- D. 7.99 -8.01

33. The capacity of a Binary Symmetric Channel (BSC) with cross-over probability 0.5 is _____

- A. 0
- B. 0.2

- C. 0.4
- D. 0.5

34. A two-port network has scattering parameters given by $[S] = \begin{bmatrix} S_{11} & S_{12} \\ S_{21} & S_{22} \end{bmatrix}$. If the port-2 of the two-port is short circuited, the S_{11} parameter for the resultant one-port network is

- A. $\frac{S_{11} - S_{11}S_{22} + S_{12}S_{21}}{1 + S_{22}}$
- B. $\frac{S_{11} - S_{11}S_{22} - S_{12}S_{21}}{1 + S_{22}}$
- C. $\frac{S_{11} - S_{11}S_{22} + S_{12}S_{21}}{1 - S_{22}}$
- D. $\frac{S_{11} - S_{11}S_{22} + S_{12}S_{21}}{1 - S_{22}}$

35. The force on a point charge +q kept at a distance d from the surface of an infinite grounded metal plate in a medium of permittivity ϵ is

- A. 0
- B. $\frac{q^2}{16\pi\epsilon d^2}$ away from the plate
- C. $\frac{q^2}{16\pi\epsilon d^2}$ towards the plate
- D. $\frac{q^2}{4\pi\epsilon d^2}$ towards the plate

Q.No. 26 – 55 Carry Two Marks Each

36. The Taylor series expansion of $3 \sin x + 2 \cos x$ is

- A. $2 + 3x - x^2 - \frac{x^3}{2} + \dots$
- B. $2 - 3x + x^2 - \frac{x^3}{2} + \dots$
- C. $2 + 3x + x^2 + \frac{x^3}{2} + \dots$
- D. $2 - 3x - x^2 + \frac{x^3}{2} + \dots$

37. For a Function $g(t)$, it is given that

$$\int_{-\infty}^{+\infty} g(t)e^{-j\omega t} dt = \omega e^{-2\omega^2} \text{ for any real value } \omega. \text{ If}$$

$$y(t) = \int_{-\infty}^t g(\tau) d\tau, \text{ then } \int_{-\infty}^{+\infty} y(t) dt \text{ is}$$

- A. 0
- B. -j
- C. $-\frac{j}{2}$
- D. $\frac{j}{2}$

38. The volume under the surface $z(x, y) = x + y$ and above the triangle in the x-y plane defined by $\{0 \leq y \leq x \text{ and } 0 \leq x \leq 12\}$ is _____.

- A. 644
- B. 720
- C. 748
- D. 864

39. Consider the matrix:

$$J_6 = \begin{bmatrix} 0 & 0 & 0 & 0 & 0 & 1 \\ 0 & 0 & 0 & 0 & 1 & 0 \\ 0 & 0 & 0 & 1 & 0 & 0 \\ 0 & 0 & 1 & 0 & 0 & 0 \\ 0 & 1 & 0 & 0 & 0 & 0 \\ 1 & 0 & 0 & 0 & 0 & 0 \end{bmatrix}$$

Which is obtained by reversing the order of the columns of the identity matrix I_6 .

Let $P = I_6 + \alpha J_6$, where α is a non-negative real number.

The value of α for which $\det(P) = 0$ is _____.

- A. 0
- B. 1
- C. 2
- D. 4

40. A Y-network has resistances of 10Ω each in two of its arms, while the third arm has a resistance of 11Ω in the equivalent D – network, the lowest value ($in\Omega$) among the three resistances is _____.

- A. 25.09
- B. 27.09
- C. 28.09
- D. 29.09

41. A 230 V rms source supplies power to two loads connected in parallel. The first load draws 10 kW at 0.8 leading power factor and the second one draws 10 kVA at 0.8 lagging power factor. The complex power delivered by the source is

- A. $(18 + j 1.5)$ kVA
- B. $(18 - j 1.5)$ kVA
- C. $(20 + j 1.5)$ kVA
- D. $(20 - j 1.5)$ kVA

42. A periodic variable x is shown in the figure as a function of time. The root-mean-square (rms) value of x is _____.

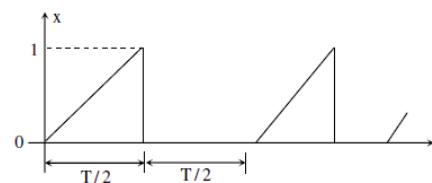

- A. 0.324
- B. 0.368
- C. 0.408
- D. 0.442

43. In the circuit shown in the figure, the value of capacitor C(in mF) needed to have critically damped response $i(t)$ is _____.

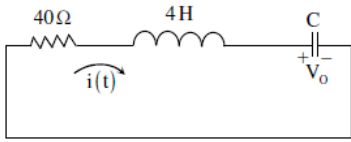

- A. 5mF
- B. 10mF
- C. 15mF
- D. 20mF

44. A BJT is biased in forward active mode, Assume $V_{BE} = 0.7V$, $kT/q = 25mV$ and reverse saturation current $I_s = 10^{-13} A$. The trans conductance of the BJT (in mA/V) is _____.

- A. 4.425
- B. 4.475
- C. 5.525
- D. 5.785

45. The doping concentrations on the p-side and n-side of a silicon diode are $1 \times 10^{16} cm^{-3}$ and $1 \times 10^{17} cm^{-3}$, A forward bias of 0.3 V is applied to the diode. At $T = 300K$, the intrinsic carrier concentration of silicon

$n_i = 1.5 \times 10^{10} cm^{-3}$ and $\frac{kT}{q} = 26mV$. The electron

concentration at the edge of the depletion region on the p-side is

- A. $2.3 \times 10^9 cm^{-3}$
- B. $1 \times 10^{16} cm^{-3}$
- C. $1 \times 10^{17} cm^{-3}$
- D. $2.25 \times 10^6 cm^{-3}$

46. A depletion type N-channel MOSFET is biased in its linear region for use as a voltage controlled resistor. Assume threshold voltage

$V_{TH} = 0.5V$, $V_{GS} = 2.0V$, $V_{DS} = 5V$, $W/L = 100$, $C_{OX} = 10^{-8} F/cm^2$ and $\mu_n = 800 cm^2/V \cdot s$. The value of

the resistance of the voltage controlled resistor (in Ω) is _____.

- A. 200 Ω
- B. 400 Ω
- C. 500 Ω
- D. 600 Ω

47. In the voltage regulator circuit shown in the figure, the op-amp is ideal. The BJT has $V_{BE} = 0.7V$ and $\beta = 100$, and the zener voltage is 4.7V. For a regulated output of 9 V, the value of R(inW) is _____.

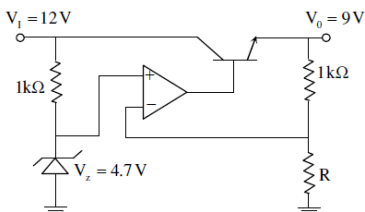

- A.893
- B. 993
- C. 1093
- D. 1193

48. In the circuit shown, the op-amp has finite input impedance, infinite voltage gain and zero input offset voltage. The output voltage V_{out} is

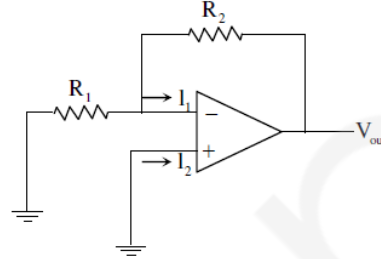

- A. $-I_2(R_1 + R_2)$
- B. $I_2 R_2$
- C. $I_1 R_2$
- D. $-I_1(R_1 + R_2)$

49. For the amplifier shown in the figure, the BJT parameters are $V_{BE} = 0.7V$, $\beta = 200$, and thermal voltage $V_T = 25mV$. The voltage gain (v_o/v_i) of the amplifier is

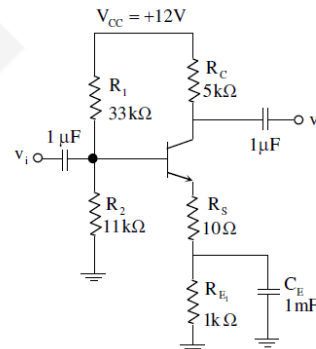

- A. 137.76
- B. -137.76
- C. 237.76
- D. -237.76

50. The output F in the digital logic circuit shown in the figure is

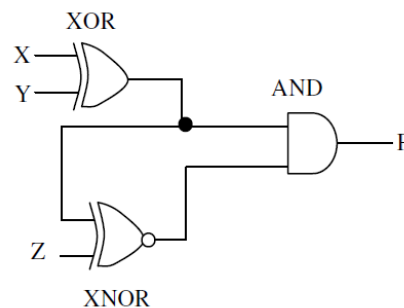

- A. $F = \overline{X}YZ + X\overline{Y}Z$
- B. $F = \overline{X}Y\overline{Z} + X\overline{Y}\overline{Z}$
- C. $F = \overline{X}\overline{Y}Z + X\overline{Y}Z$

D. $F = \overline{XYZ} + XYZ$

51. Consider the Boolean function, $F(w, x, y, z) = wy + xy + \overline{w}xyz + \overline{w}xy + xz + \overline{xy}z$. which one of the following is the complete set of essential prime implicants?

- A. w, y, xz, \overline{xz} B. w, y, \overline{xz}
- C. y, \overline{xyz} D. y, xz, \overline{xz}

52. The digital logic shown in the figure satisfies the given state diagram when Q1 is connected to input A of the XOR gate.

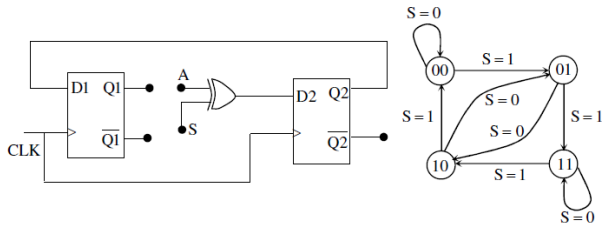

Suppose the XOR gate is replaced by an XNOR gate. Which one of the following options preserves the state diagram?

- A. Input A is connected to $\overline{Q2}$
- B. Input A is connected to $Q2$
- C. Input A is connected to $\overline{Q1}$ and S is complemented
- D. Input A is connected to $\overline{Q1}$

53. Let $x[n] = \left(\frac{1}{-9}\right)^n u(n) - \left(-\frac{1}{3}\right)^n u(-n-1)$. The Region of Convergence (ROC) of the z-transform of $x[n]$

- A. $is|z| > \frac{1}{9}$ B. $is|z| < \frac{1}{3}$
- C. $is\frac{1}{3} > |z| > \frac{1}{9}$ D. does not exist.

54. Consider a discrete time periodic signal $x[n] = \sin\left(\frac{\pi n}{s}\right)$. Let a_k be the complex Fourier series coefficients of $x[n]$. The coefficients $\{a_k\}$ are non-zero when $k = Bm \pm 1$, where m is any integer. The value of B is _____.

- A. 5 B. 10 C. 15 D. 20

55. A system is described by the following differential equation, where $u(t)$ is the input to the system and $y(t)$ is the output of the system.

$$y(t) + 5y(t) = u(t)$$

When $y(0) = 1$ and $u(t)$ is a unit step function, $y(t)$ is

- A. $0.2 + 0.8e^{-5t}$ B. $0.2 - 0.2e^{-5t}$
- C. $0.8 + 0.2e^{-5t}$ D. $0.8 - 0.8e^{-5t}$

56. Consider the state space model of a system, as given below

$$\begin{bmatrix} \dot{x}_1 \\ \dot{x}_2 \\ \dot{x}_3 \end{bmatrix} = \begin{bmatrix} -1 & 1 & 0 \\ 0 & -1 & 0 \\ 0 & 0 & -2 \end{bmatrix} \begin{bmatrix} x_1 \\ x_2 \\ x_3 \end{bmatrix} + \begin{bmatrix} 0 \\ 4 \\ 0 \end{bmatrix} u, y = [1 \ 1 \ 1] \begin{bmatrix} x_1 \\ x_2 \\ x_3 \end{bmatrix}$$

The system is

- A. controllable and observable
- B. uncontrollable and observable
- C. uncontrollable and unobservable
- D. controllable and unobservable

57. The phase margin in degrees of

$$G(s) = \frac{10}{(s+0.1)(s+1)(s+10)}$$

calculated using the asymptotic Bode plot is _____.

- A. 32 B. 36 C. 42 D. 48

58. For the following feedback system

$$G(s) = \frac{1}{(s+1)(s+2)}$$

The 2% settling time of the step response is required to be less than 2 seconds.

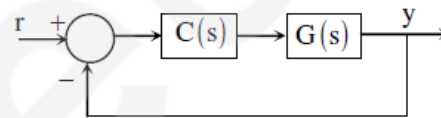

Which one of the following compensators $C(s)$ achieves this?

- A. $3\left(\frac{1}{s+5}\right)$ B. $5\left(\frac{0.03}{s} + 1\right)$
- C. $2(s+4)$ D. $4\left(\frac{s+8}{s+3}\right)$

59. Let x be a real-valued random variable with $E[X]$ and $E[X^2]$ denoting the mean values of X and X^2 , respectively. The relation which always holds true is

- A. $(E[X])^2 > E[X^2]$
- B. $E[X^2] \geq (E[X])^2$
- C. $E[X^2] = (E[X])^2$
- D. $E[X^2] > (E[X])^2$

60. Consider a random process $X(t) = \sqrt{2} \sin(2\pi t + \phi)$, where the random phase ϕ is uniformly distributed in the interval $[0, 2\pi]$. The auto-correlation $E[X(t_1)X(t_2)]$

- A. $\cos(2\pi(t_1 + t_2))$
- B. $\sin(2\pi(t_1 - t_2))$
- C. $\sin(2\pi(t_1 + t_2))$

D. $\cos(2\pi(t_1 - t_2))$

61. Let $Q(\sqrt{\gamma})$ be the BER of a BPSK system over an

AWGN channel with two-sided noise power spectral density $N_0/2$. The parameter γ is a function of bit energy and noise power spectral density.

A system with two independent and identical AWGN channels with noise power spectral density $N_0/2$ is shown in the figure. The BPSK demodulator receives the sum of outputs of both the channels.

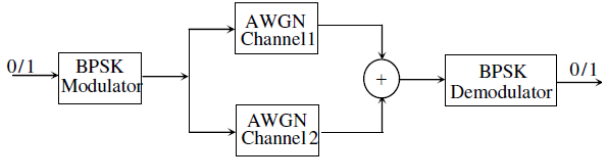

If the BER of this system is $Q(b\sqrt{\gamma})$, then the value of b is _____.

- A. 1.212 B. 1.313
- C. 1.414 D. 1.515

62. A fair coin is tossed repeatedly until a 'Head' appears for the first time. Let L be the number of tosses to get this first 'Head'. The entropy H(L) in bits is _____.

- A. 1
- B. 2
- C. 3
- D. 4

63. In spherical coordinates, let $\hat{a}_\theta, \hat{a}_\phi$ denote unit vectors along the θ, ϕ directions.

$$E = \frac{100}{r} \sin \theta \cos(\omega t - \beta r) \hat{a}_e V / m \quad \text{and}$$

$$H = \frac{0.265}{r} \sin \theta \cos(\omega t - \beta r) \hat{a}_\phi A / m$$

represent the electric and magnetic field components of the EM wave of large distances r from a dipole antenna, in free space. The average power (W) crossing the hemispherical shell located at

$$r = 1km, 0 \leq \theta \leq \pi / 2 \text{ is } \underline{\hspace{2cm}}$$

- A. 45.5
- B. 55.5
- C. 65.5
- D. 75.5

64. For a parallel plate transmission line, let v be the speed of propagation and Z be the characteristic impedance. Neglecting fringe effects, a reduction of the spacing between the plates by a factor of two results in

- A. halving of v and no change in Z
- B. no change in v and halving of Z
- C. no change in both v and Z
- D. halving of both v and Z

65. The input impedance of a $\frac{\lambda}{8}$ section of a lossless transmission line of characteristic impedance 50Ω is found to be real when the other end is terminated by a load $Z_L (= R + jX)\Omega$, the value of R (in Ω) is _____

- A. 30
- B. 40
- C. 50
- D. 60
