

ELECTRICAL ENGINEERING

PRACTICE SET- 2

Q.1:- Two materials have resistance temperature coefficients of 0.004 and 0.0002 respectively at a given temperature. In what ratio should the wires made of these materials be connected in series so as to have an overall temperature coefficient of 0.002?

- (a) 1:2 (b) 2:3 (c) 9:10 (d) 15:16

Q.2:- Consider the two fields,

$$E = 120 \pi \cos (10^6 \pi t - \beta x) a_y \text{ V / m}$$

And

$$H = A \cos (10^6 \pi t - \beta x) a_z / \text{m}.$$

The values of A and β which will satisfy the Maxwell's equation in a linear isotropic, homogeneous, loss-less-medium with $\epsilon_r = 8$ and

$\mu_r = 2$ will be

| <u>A (in A / m)</u> | <u>β (in rad / m)</u> |
|---------------------|--|
| (a) 1 | 0.0105 |
| (b) 1 | 0.042 |
| (c) 2 | 0.0105 |
| (d) 2 | 0.042 |

Q.3:- A chopper operating at a fixed frequency is feeding an R-L load. As they duty ratio of the choppe is increased from 25% to 75%, the ripple in the load current.

- (a) Remains constant.
- (b) Decreases, reaches a minimum at 50% duty ratio and then increases.
- (c) Increases, reaches a maximum at 50% duty ratio and then decreases.
- (d) Keeps on increasing as the duty ratio is increased.

Q.4:- A sinusoidal waveform, when observed on an oscilloscope, has a peak to peak amplitude of 6cm. If the vertical sensitivity setting is 5 V / cm, the rms value of the voltage will be

- (a) 10.6 V (b) 11.1 V (c) 12.6 V (d) 15 V

Q.5:- Which of the following is an example of an open-loop system?

- (a) Household refrigerator.
- (b) Respiratory system of an animal.
- (c) Stabilization of air pressure entering into a mask.
- (d) Execution of a program by a computer.

Q.6:- A binary tree T has n leaf nodes. The number of nodes of degree 2 in T is

- (a) $\log_2 n$ (b) $n - 1$
(b) (c) n (d) 2^n

Q.7:- An n-channel silicon ($E_g = 1.1$ eV) MOSFET was fabricated using n^+ poly silicon gate and the threshold voltage was found to be 1 V. Now, if the gate is changed to p^+ poly-silicon, other things remaining the same, the new threshold voltage should be

- (a) -0.1 V (b) 0 V (c) 1.0 V (d) 2.1 V

Q.8:- Scintillation is

- (a) Variation of physical dimensions under the influence of magnetic field.
- (b) Deionization of gases under low pressures.
- (c) Production of flashes of light by some substances when struck by alpha, beta or gamma rays.
- (d) Change in dielectric constant of substances with change in humidity.

Q.9:- Which of the following statements is true?

- (a) ROM is Read /Write memory.
- (b) PC points to the last instruction that was executed.
- (c) Stack works on the principle of LIFO.
- (d) All instructions affect the flags.

Q.10:- In which range the cost of a synchronous motor is likely to be comparable to the cost of induction motor?

- (a) Low H.P., high speed.
- (b) High H.P., low speed.
- (c) High H.P., high speed.
- (d) Low H.P., low speed.

Q.11:- which one of the theories given below is related to the theory of the thermocouple?

- (a) Piezoelectric effect (b) Skin effect (c) See back effect (d) Faraday's Law

Q.12:- For the purpose of analysis exact equivalent circuit of a transformer is usually replaced by an approximate equivalent circuit. In doing so errors introduced due to winding copper loss and core loss are of differential nature. Due to this the analysis by approximate equivalent circuit gives fairly satisfactory results. Under the circumstance, which one of the following is correct in respect of losses referred to approx. Equivalent circuit?

- (a) This accounts for somewhat greater primary winding copper loss and more cores less core loss.
- (b) This accounts for somewhat lesser primary winding copper loss and more core loss.
- (c) This accounts for somewhat greater secondary winding copper loss and less core loss
- (d) This accounts for somewhat lesser secondary winding copper loss and more core loss.

Q.13:- Consider the following statements: In a 3-phase induction motor connected to a 3-phase supply; if one of the lines suddenly gets disconnected, then the

1. Motor will come to a standstill.
2. Motor will continue to run at the same speed with line current unchanged.
3. Motor will continue to run at a slightly reduced speed with increased line current.
4. Rotor currents will have both sf and a $(2-s)f$ component frequency where s is the slip and f is the supply frequency.

Of these statements:

- (a) 1 and 4 are correct
- (b) 1 and 2 are correct
- (c) 3 and 4 are correct
- (d) 2 and 3 are correct

Q.14:- While a 2-phase ac servomotor is in operation, if the voltage across the control field winding becomes zero, then the motor has a tendency to run as a single-phase induction motor. To prevent this

- (a) rotor having high mass moment of inertia is used for such a motor
- (b) drag cup type of light rotor with high rotor resistance is preferred
- (c) a low rotor resistance is used
- (d) The number of turns in the control field winding used is less than the main reference winding.

Q.15:- The inertia constant of a 100 MVA, 11 KV water wheel generators is 4. The energy stored in the rotor at the synchronous speed is

- (a) (a) 400 MJ
- (b) 400 KJ
- (b) (c) 25 MJ
- (d) 25 KJ.

Q.16:- A separately excited dc generator is feeding a shunt motor. If the load torque on the motor is halved approximately.

- (a) Armature currents of both motor and generator are halved.
- (b) Armature current of motor is halved and that of generator is unaltered.
- (c) Armature current of generator is halved and that of motor is unaltered.
- (d) Armature currents of both motor and generator are unaltered.

Q.17:- Which variety of coal has lowest calorific value?

- (a) Steam coal
- (b) Bituminous coal
- (c) Lignite
- (d) Anthracite

Q.18:- The Current through an electrical conductor is 1 ampere when the temperature of the conductor is 0°C and 0.7 ampere when the temperature of the conductor is 1200°C must be

- (a) 0.08 A
- (b) 0.16 A
- (C) 0.32 A
- (d) 0.64 A

Q.19:- The velocity of a travelling electromagnetic wave in free space is given by

- (a) $\mu_0 \epsilon_0$
- (b) $\sqrt{\mu_0 \epsilon_0}$
- (c) $\frac{1}{\sqrt{\mu_0 \epsilon_0}}$
- (d) $\frac{1}{\mu_0 \epsilon_0}$

Q.20:- When a thyristor is negatively biased

- (a) all the three junctions are negatively biased .
- (b) outer junctions are positively biased and the inner junction is negatively biased.
- (c) outer junction are negatively biased and the inner junction is positively biased a.
- (d) the junction near the anode is negatively biased and the one near the cathode is positively biased.

Q.21:- In the two-wattmeter method of measuring power in a balanced three-phase circuit, one wattmeter shows zero and the other positive maximum. The load power factor is

- (a) zero (b) 0.5 (c) 0.866 (d) 1.0

Q.22:- If the unit step response of a system is a unit impulse function, then the transfer function of such a system will be

- (a) 1 (b) $1/s$ (c) s (d) $1/s^2$

Q.23:- The probability that a number selected at random between 100 and 999 (both inclusive) will not contain the digit 7 is

- (a) $16/25$ (b) $(9/10)^3$ (c) $27/75$ (d) $18/25$

Q.24:- In the circuit shown in the figure, N is a finite gain amplifier with a gain of k , a very high input impedance, and a very low output impedance. The input impedance of the feedback amplifier with the feedback Z

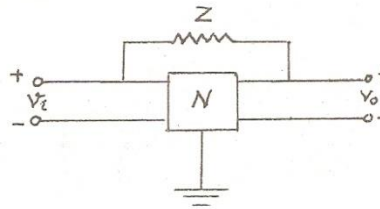

connected, as shown will be

- (a) $Z(1 - 1/k)$
(b) $Z(1 - k)$
(c) $Z(k - 1)$
(d) $Z(1 - k)$

Q.25:- A satellite carrying antenna system, transmitter, receiver and power supply is known as

- (a) geostationary satellite
(b) orbital satellite
(c) active satellite
(d) passive satellite

Q.26:- In a virtual memory system, the address space specified by the address lines of the CPU must be _____ than the secondary storage size.

- (a) smaller, smaller
(b) smaller, larger
(c) larger, smaller
(d) larger, larger

Q.27:- Wires are made by

- (a) spinning
(b) rolling
(c) drawing
(d) turning

Q.28:- Based on the cohesive energy of an ionic solid, which of the following is not a property of the ionic solid?

- (a) It forms relatively stable and hard crystals
- (b) It is a poor electric conductor
- (c) It has a higher vaporization temperature
- (d) None of the above.

Q.29:- If the wave-form of the voltage impressed on the primary of a Y- Δ bank contains a 5th harmonic, the wave-forms of the resultant voltages of primary and the secondary would be

| <u>Primary</u> | <u>Secondary</u> |
|-----------------|------------------|
| (a) Peaked | peaked |
| (b) Peaked | flat-topped |
| (c) Flat-topped | peaked |
| (d) Flat-topped | flat-topped |

Q.30:- In a self-excited induction generator, to keep the frequency of generated voltage constant with the increase in load the speed of the induction machine should be

- (a) Increased.
- (b) Decreased.
- (c) Maintained less than the rated synchronous speed.
- (d) Maintained more than the rated synchronous speed.

Q.31:- The speed of a universal motor can be controlled by

- (a) introducing a variable resistance in series with the motor
- (b) tapping the field at various points
- (c) centrifugal mechanism
- (d) all of the above steps

Q.32:- A large a.c. generator, supplying to an infinite bus, has a sudden short-circuit occurring at its terminals. The voltage behind the transient reactance to remain constant immediately after the fault, the acceleration of the generator rotor is

- (a) inversely proportional to the moment of inertia of the machine
- (b) inversely proportional to the square of the voltage
- (c) directly proportional to the square of the short-circuit current
- (d) Directly proportional to the short-circuit power.

Q.33:- An electric train employing a dc series motor is running at a fixed speed, when a sudden slight drop in the mains voltage occurs. This would result in

- (a) drop in speed and rise in current
- (b) rise in speed and drop in current
- (c) rise in speed and rise in current
- (d) Drop in speed with current unaltered.

Q.34:- Ball mill is used in power plants using

- (a) multi-stage expansion
- (b) water softening
- (c) fly ash removal from flue gases
- (d) Pulverized fuel firing

Q.35:- In the circuit shown in figure, $I_B = 10$ micro-amperes. The value of resistance R_{in} is

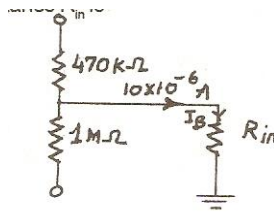

- (a) 1 kilo-ohm
- (b) 10 kilo-ohm
- (c) 100 kilo-ohm
- (d) 1 Mega-ohm

Q.36:-The equation of a plane wave may be written as (with) usual symbols

- (a) $\frac{\partial^2(E_y)}{\partial t^2} = \frac{1}{\mu\epsilon} \frac{\partial^2 E_y}{\partial x^2}$
- (b) $\frac{\partial^2(E_y)}{\partial x^2} = \frac{1}{\mu\epsilon} \frac{\partial^2 E}{\partial t^2}$
- (c) $\frac{\partial^2(E_y)}{\partial t^2} = \frac{\mu}{\epsilon} \frac{\partial^2 E}{\partial x^2}$
- (d) $\frac{\partial^2(E_y)}{\partial t^2} = \frac{\epsilon}{\mu} \frac{\partial^2 E}{\partial x^2}$

Q.37:- A single-phase voltage source square-wave inverter feeds pure inductive load. The waveform of the load current will be

- (a) Sinusoidal
- (b) rectangular
- (c) trapezoidal
- (d) triangular

Q.38:- A 35V dc supply is connected across a resistance of 600 ohm in series with an unknown resistance R_x . A voltmeter having a resistance of 1.2 k-ohms reads 5V. The value of resistance R_x will be

- (a) 120 ohm
- (b) 400 ohm
- (c) 1.8 k-ohm
- (d) 2.4 k-ohm

Q.39:- When a unit-step input is applied, a second order under damped system has a peak overshoot of OP occurring at t_{max} . If another step input equal in magnitude to the peak overshoot OP is applied at $t = t_{max}$ then the system will settle down at

- (a) $1 + OP$
- (b) $1 - OP$
- (c) OP
- (d) 1.0

Q.40:- Let R be a symmetric and transitive relation on a set A. Then

- (a) R is reflexive and hence an equivalence relation
- (b) R is reflexive and hence a partial order
- (c) R is not reflexive and hence not a an equivalence relation
- (d) None of the above.

Q.41:- In a bipolar transistor at room temperature, If the emitter current is doubled, the voltage across its base-emitter junction

- (a) Doubles
- (b) halves
- (c) increases by about 20 mV
- (d) decreases by about 20 mV

Q.42:- F_2 layer has maximum ionic density of 3.5×10^6 electrons per cc. The critical frequency for this layer will be

- (a) 1.68 MHz (b) 400 MHz (c) 400 KHz (d) 40 KHz

Q.43:- An instruction used to set the carry Flag in a computer can be classified as

- (a) Data transfer (b) arithmetic (c) logical (d) Program control

Q.44:- 'Figure of Merit' is used to

- (a) compare the efficiency of the thermoelectric materials
(b) measure the extent of doping of intrinsic semiconductors
(c) compare the extent of purity of semi-conductor materials
(d) None of the above.

Q.45:- A certain photoconductive cell is known to have a critical wave-length of 0.5 micrometer. Then the minimum energy required to move an electron from the valence band to the conduction band is:

- (a) 0.96 electric volt (b) 0.31 electron volt (c) 0.62 electric volt (d) 2.48 electron volts

Q.46:- A 50 Hz operation, a single-phase transformer has hysteresis loss of 200 W and eddy current loss of 100 W. Its core loss at 60 Hz operation will be

- (a) 432 W (b) 408 W (c) 384 W (d) 360 W

Q.47:- Cogging and crawling are phenomena associated with

- (a) cage induction machines and they are essentially the same
(b) squirrel cage induction machine, the former at a fraction of its rated speed and the latter during starting
(c) squirrel cage induction machine, the former during starting and the latter at a fraction of its rated speed
(d) Wound rotor induction machines and they are reduced by skewing, chording and distribution of windings.

Q.48:- Match List-1 (type of single-phase motor) with List-2 (type of appliance) and select the correct answer using the codes given below the lists:

List-1

A. Permanent magnet type

B. Shaded pole

C. Universal

D. Capacitor shunt, capacitor run induction motor

List-2

1. Rocket

2. Refrigerator compressor

3. Sewing machine

4. Photocopying machine

Codes:

(a) A B C D

1 2 3 4

(b) A B C www.recruitment.guru

- | | | | | |
|-----|---|---|---|---|
| | 1 | 2 | 4 | 3 |
| (c) | A | B | C | D |
| | 4 | 1 | 3 | 2 |
| (d) | A | B | C | D |
| | 1 | 4 | 3 | 2 |

Q.49:- The fifth harmonic component of the induced voltage in 3-phase ac generator can be entirely eliminated by using a winding pitch of

- (a) 2 / 3 (b) 4 / 5 (c) 5 / 6 (d) 6 / 7

Q.50:- Consider the following drive systems:

1. Chopper fed dc series motor
2. Chopper fed dc shunt motor
3. Chopper fed permanent magnet dc motor
4. Brushless dc motor drive
5. Inverter fed 3-phase induction motor
6. Inverter fed 3-phase synchronous motor

For the development of a battery operated electric car the possible options are

- (a) 1 , 3 and 5
- (b) 2 , 4 and 6
- (c) 1 and 5
- (d) 1 , 4 and 5

Solution

1:- (c) Let the materials be in the ratio of $k = x / y$

$$\therefore \frac{0.004x + 0.0002y}{x+y} = 0.002$$

$$\therefore \frac{0.004ky + 0.0002y}{ky+y} = 0.002$$

$$\therefore \frac{0.004x + 0.0002y}{k+1} = 0.002$$

$$\therefore 0.004k + 0.0002 = 0.002$$

$$\therefore 0.002k = 0.0018$$

$$\therefore k \frac{0.0018}{0.0020} = \frac{9}{10}$$

Hence, the materials should be in the ratio 9:10.

2:- (d) $E / H = \eta$, the characteristic impedance of the medium.

$$\eta = \sqrt{\frac{\mu}{\epsilon}} = \sqrt{\frac{\mu_0}{\epsilon_0}} \sqrt{\frac{\mu_r}{\epsilon_r}}$$

$$= 120\pi \sqrt{\frac{\mu_r}{\epsilon_r}}$$

$$= 120\pi \times \sqrt{\frac{2}{8}} = 120\pi \times \frac{1}{2}$$

$$\therefore A = \frac{120\pi}{120\pi \times 1/2} = 2$$

Also, $\beta = w/v$

Here, $w = 10^6\pi$, $v = \sqrt{\frac{1}{\mu\epsilon}}$

$$= 3 \times 10^8 \sqrt{\frac{1}{2 \times 8}}$$

$$= \frac{3 \times 10^8}{4}$$

$$\therefore \beta = \frac{10^6\pi}{3 \times 10^8} \times 4 = \frac{0.04\pi}{3} = 0.042$$

3:- (a) Load voltage $E_L = \frac{E}{T_{ON} + T_{OFF}} \times T_{ON}$

$$= E \frac{T_{ON}}{T} = E f T_{ON}$$

There are two ways to vary E_L either by varying f or T_{ON} . Here frequency is fixed and T_{ON} is varied. As the frequency is kept constant ripple remains constant.

4:- (a) Amplitude of the signal is $\frac{6 \times 5}{2} = 15$ V.

\therefore rms value is $\frac{15}{\sqrt{2}} = 10.6$ V.

5:- (d) Execution of a program by a computer is an example of an open-loop system.

6:- (b) It can be proved by induction that a strictly binary tree with 'n' leaf nodes will have a total number of $2n-1$ nodes. So number of non-leaf nodes is $(2n-1) - n = n-1$.

7:- (c) 1.0 V

8:- (c) Certain crystals such as zinc sulphide, sodium iodide, anthracene and naphthalene, etc. produce a brief flash of light each time they are struck by an alpha or beta or gamma particles. The production of a flash of light by striking the crystals mentioned above, with alpha, beta or gamma rays, is called scintillation.

9:- (c) Stack works on the principle of LIFO.

10:- (b) the cost of an induction motor increase disproportionately in high H.P. range and also as operating speed reduces. It is, therefore, in this range where the cost of the two machines is comparable.

11:- (c) "An electromotive force results from a difference of temperature between two junctions of dissimilar metals in the same circuit."

This effect was first noted by Thomas Johanna See back. The difference of electric potential which results from the difference in junction temperatures is dependent upon the metals used, the temperatures of

the junction, and the intimacy of contact between the two metals. Such a combination of dissimilar metals, when used to produce an emf, is called a thermocouple, and has many uses in the measurement of temperature.

12:- (b)

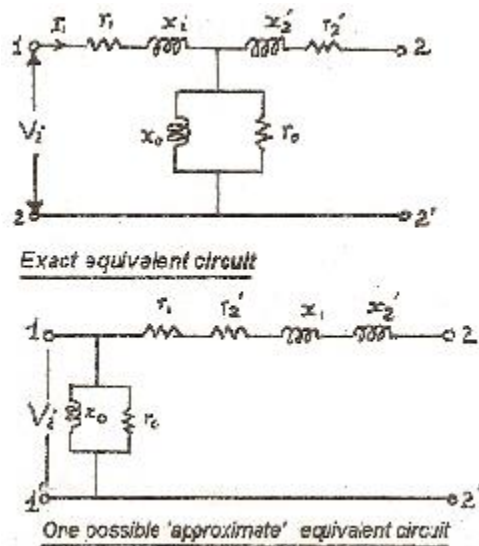

I_0 'Shall be slightly greater than I_0 and therefore, slightly greater core loss Current flowing through r_1 is now somewhat less than I_1 and therefore reduced copper loss in it

Note: - If the shunt branch is shifted to 2-2', then the answer would be (c). It depends on which approximate circuit is used. The one given above is more common.

13:- (c) The motor will not stop. It will continue to run as a single phase motor with two phases of the windings connected in series (for a star- connected) and third phase open; while for a delta – connected motor, one phase of the winding and two other phases in series of the winding are in parallel. The field in the air gap is pulsating which can be resolved into a forward rotating components. The rotor, therefore, has both $s f$ and $(2 - s) f$ component frequencies.

14:- (b) Drag cup type of light rotor with high rotor resistance is preferred.

15:- (a) Inertia constant H

Mega joules of energy stored in the rotating mass of the alternator at

$$= \frac{\text{synchronous speed, } E}{\text{Rating in MVA of the alternator's}}$$

$$\text{Thus, } 4 = \frac{E}{100}$$

$$\therefore E = 400 \text{ MJ.}$$

16:- (a) Since field winding currents of the two machines are not disturbed and the torque is proportional to the product of armature current and field flux, when the torque reduced to half, the armature current in both also reduces to half.

17:- (c) Lignite coal has lowest calorific value.

18: (b) Let α be the temperature coefficient.

Then $R_t = R_0 (1 + \alpha t)$

Where R_t is resistance at $t^\circ \text{C}$ and R_0 is resistance at 0°C

Assuming that for a given potential to $1 / R$

We have

$$\frac{1 \text{ amp}}{0.7 \text{ amp}} = \frac{R_0 (1 + \alpha t)}{R_0} = 1 + .100$$

0.7 amps,

$$\therefore \alpha = 0.0043 \text{ per } ^\circ \text{C}$$

The current I , at 1200°C is given by

$$\frac{1}{I} = \frac{R_0 (1 + \alpha .1200)}{R_0} = 1 + .1200$$

$$= 1 + 0.0043 \times 1200 = 6.16$$

$$\therefore I = 1 / 6.16 = 0.16 \text{ amp.}$$

19:- (c) A standard relation $VO = \sqrt{\frac{1}{\mu_0 \epsilon_0}}$

20:- (c) When a thyristor is negatively biased, outer junctions are negatively biased and the inner junction is positively biased.

21:- (b) the wattmeter read

$$\text{One} \propto \cos(30 + \phi)$$

$$\text{Then other} \propto \cos 30 - \phi$$

Thus whenever load p.f. angle ϕ becomes 60° one of the watt meters would read zero.

\therefore For the given condition the load p.f. is

$$\text{Cos } 60^\circ = 0.5$$

22:- (c) Input $r(t) = u(t) \therefore R(s) = 1/s$

$$\text{Out put } c(t) = \delta(t) \therefore C(s) = 1$$

$$\text{Transfer function} = \frac{C(s)}{R(s)} = \frac{1}{1/s} \text{ s.}$$

23:- (d) Probability that the unit digit is not 7 is $9 / 10$. Probability that the tens digit is not 7 is $9 / 10$. Probability that the hundreds digit is not 7 is $8 / 9$. So, probability that the unit digit is not 7 and the tens digit is not 7 and the hundreds digit is not 7 is:

$$(9 / 10) (9 / 10) (8 / 9) = 18 / 25.$$

24:- (d) From Miller's theorem $Z_i = Z / 1 - K$.

25:- (c) The active satellite carries antenna system transmitter receiver and power supply. It works as an active micro-wave repeaters, relay and signal to the receiving station either instantly or after storage in its memory and waiting until the satellite faces the earth based receiving station.

26:- (c) Larger, smaller.

27:- (c) Wire-drawing process is used for making wires of various diameters.

28:- (d) the cohesive energy, which is the energy needed to take the solid apart into positive and negative ions, is relatively high for ionic solids. Therefore, they should be poor electrical conductors since there are no free elections available. They should be hard and stable with high vaporization temperatures and high melting points.

29:- (b) Peaked- flat topped.

30:- (a) When a slip becomes negative, the induction machine acts as a generator, therefore, the rotor speed should be more than the rated synchronous speed. Further, as the load increases, slip magnitude should increase as the power output is approximately proportional to slip magnitude for small slips. Therefore, speed will have to be increased.

31:- (b) It can be controlled by tapping the field at various points.

32:- (a) $M \frac{d^2\delta}{dt^2} = P_s - P_e$

M : Moment of inertia of the machine

$\frac{d^2\delta}{dt^2}$: Second time derivative of the load or the torque angle which turns out to be same as rotor acceleration.

P_s : Shaft power

P_e : Electrical power output

Since $P_e \approx 0$ on occurrence of a short circuit,

We have $\frac{d^2\delta}{dt^2} = \frac{P_s}{M}$

33:- (d) In a series motor, the torque is approximately proportional to current squared. The train resistance speed curve is such that there is very little increase in torque with speed; we can assume that torque remains constant. Therefore, the armature current remains constant with increase in applied voltage, the back emf reduces, which is achieved by a drop in speed.

34:- (d) Ball mill is used in power plants using pulverized fuel firing.

35:- (c) Let the current I_{B1} flow through resistance R_{in} when – 12V Battery is removed. So,

$$R_{in} = \frac{12}{470 \times 1000 + R_{in}}$$

Similarly current I_{B2} flow in resistance R_{in} When + 12 V battery is removed. So,

$$I_{B2} = \frac{12}{1000 \times 1000 + R_{in}}$$

Since the two voltages are in opposite directions, their currents will subtract. Hence,

$$\frac{12}{470 \times 1000 + R_{in}} - \frac{12}{1000 \times 1000 + R_{in}}$$

$$= 10 \times 10^{-6}$$

$$12(1000 \times 1000 + R_{in}) - 12(470 \times 1000 + R_{in})$$

$$10 \times 10^{-6}(1000 \times 1000 + R_{in}) \times (470 \times 1000 + R_{in})$$

$$R_{in}^2 + 1470 \times 1000 R_{in} - 16.6 \times 10^9 = 0$$

Solving for R_{in} we have

$$R_{in} = \frac{-1470 \times 1000 \pm \sqrt{(1470 \times 1000)^2 + 66.4 \times 10^9}}{2}$$

10, 1000 ohms (rejecting the negative value)

36:- (a) One may arrive at the correct choice by comparing the two sides dimensionally. Since $1 / \mu\epsilon$ has the dimension of velocity squared,

The pertinent choice is $\frac{\partial^2 E}{\partial t^2} y = \frac{1}{\mu\epsilon} \frac{\partial^2 E}{\partial x^2} y$

37:- (d) The waveform of the load current will be triangular.

38:- (d) The voltage across R_x is $V_x = 35 - 5 = 30V$. The current in the circuit is

$$\frac{5}{\frac{600 \times 1200}{600 + 1200}} = \frac{5}{400} \text{ A}$$

$$R_x = \frac{30 \times 400}{5} = 2.4 \text{ k}$$

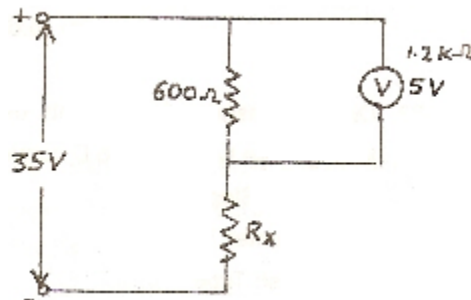

39:- (a) It will settle down at 1+ OP.

40:- (c) Let aRb . Since the relation is symmetric bRb . Since transitivity holds good, aRb and bRa implied aRa . Also bRa implies aRa and bRb . If R has to be an equivalence relation, it has to be reflexive, i.e. for any x belonging to A , xRx should hold good. So, R need not be reflexive and so R need not be an equivalence relation.

For example, let $a = (1, 2, 3)$

Let $R = \{(1,2),(2,1),(1,1),(2,2)\}$

R is both symmetric and transitive but R is not reflexive as $(3,3)$ is not present in R .

41:- (c) Its base-emitter junction increases by about 20 mV.

42:- (b) Critical Frequency, $f_c = 9 \sqrt{N_{max}}$

$$= 9 \sqrt{3.5 \times 10^6 \times 10^{-6}} = 16.839 \text{ MHz.}$$

43:- (b) Arithmetic

44:- (a) "Figure of merit" is used to compare the efficiency of thermo-electric materials.

45:- (d) The minimum energy of a photon required to excite an electron from the valence band to the conduction band is the forbidden energy gap of that semiconductor material. The relationship between the wavelength of the photon and the energy gap is given by

$$\lambda_c = \frac{1.24}{E_g}$$

E_g = energy gap = minimum energy required to move an electron from the valence band to the conduction band, in electron volts. λ_c = Critical wavelength of the photon (micrometers).

1.24 = constant that arises from the Planck's constant.

Substituting the given data,

$$E_g = \frac{1.24}{0.5} = 2.48 \text{ electron volt.}$$

46:- (c) If the operation of the transformer is at the same rms value of the voltage, then

$$\frac{B_{m1}}{B_{m2}} = \frac{f_2}{f_1} \text{ or } B_{m2} = \frac{5}{6} B_{m1}$$

$$\text{Hysteresis loss} = P_{h1} = K_h f B_{m1}^{1.6}$$

$$\begin{aligned} P_{h2} &= P_{h1} \left(\frac{B_{m2}}{B_{m1}} \right)^{1.6} = P_{h1} \left(\frac{B_{m2}}{B_{m1}} \right)^{0.6} \\ &= 200 \times \left(\frac{5}{6} \right)^{0.6} = 179.3 \text{ W} \end{aligned}$$

Eddy current loss, $P_e = K_e f^2 B_{m2}^2$

Thus eddy current loss is not affected. And the total loss is $179.3+100=279.3\text{W}$. This does not tally with any of the given answers. Assume, the before that the flux density value is not change. Then

$$P_{h2} = 200 \times \left(\frac{6}{5} \right)^{0.6} = 240 \text{ W}$$

$$P_{e2} = 100 \times \left(\frac{6}{5} \right)^2 = 144 \text{ W.}$$

∴ Total loss = 384 W.

47:- (c) Cogging and crawling are phenomena associated with squirrel cage induction machine, the former during starting and later at a fraction of its rated speed.

48:- (d) A – 1, B – 4, C – 3, D - 2.

49:- (b) Coil span factor for n_{th} harmonic is

$$K_c = \cos \frac{1}{2} n \epsilon$$

Where ϵ is the angle by which the coil is short of full pitch?

$$K_c = \cos \frac{1}{2} \times 5 \times \left(1 - \frac{4}{5}\right) \quad \pi = 0$$

Thus fifth harmonic component gets eliminated by using a coil pitch of 4/5.

50:- (a) 1, 3 and 5 are Correct.