



**W'05 : 4 AN : EC 404 (1480)**

**CIRCUIT THEORY AND CONTROL**

**Time : Three hours**

**Maximum marks : 100**

**Answer FIVE questions, taking ANY TWO from Group A,  
ANY TWO from Group B and ALL from Group C.**

**All parts of a question (a, b, etc) should be  
answered at one place.**

**Answer should be brief and to-the-point and be supple-  
mented with neat sketches. Unnecessary long answers  
may result in loss of marks.**

**Any missing data or wrong data may be assumed suitably  
giving proper justification.**

**Figures on the right-hand side margin indicate full marks.**

**Group A**

1. (a) Define the following: 5 + 5
- (i) Tree of a connected graph
- (ii) Incidence matrix.

- (b) Express the Branch voltages in terms of two sets of node to datum voltages for Fig. 1. 10

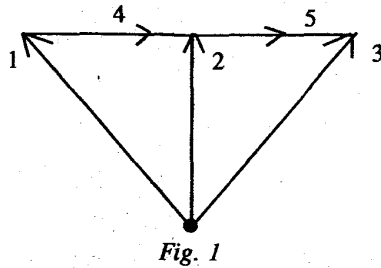

2. (a) State and explain the following: 5 + 5

(i) Initial value theorem

(ii) Convolution integral.

- (b) In Fig. 2 switch (S) is closed after steady state is reached at  $t=0$ ; determine  $V(t)$  for  $t>0$ . Assume consistent units: volt,  $\Omega$  and Farad. 10

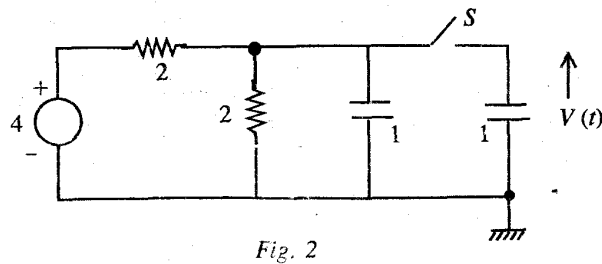

3. (a) Define Pole and Zero of a Network Function. 4 + 4

4AN: EC 404 (1480)

( 2 )

(Continued)

- (b) For a parallel-Tuned-RLC circuit, determine the Driving Point Impedance  $Z(s)$  and define

(i) Quality Factor ( $Q$ )

(ii) Resonant Frequency ( $\omega_0$ )

Draw the Frequency-Response characteristics of  $Z(j\omega)$ . 3 + 3 + 3 + 3

4. (a) What is meant by Maximally Flat-Magnitude Function (MFMF)? 5

- (b) Determine the relations among coefficients  $\alpha$ ,  $\beta$  and  $\gamma$  of the given function  $T(s)$  such that  $|T(j\omega)|^2$  is MFMF

$$T(s) = \frac{s + \alpha}{s^2 + \beta s + \gamma}$$

10

- (c) Define the Butterworth Network function. 5

**Group B**

5. (a) Define: 3 + 3

(i) Open-loop system

(ii) Closed-loop system.

- (b) What is Negative Feedback? Describe briefly the effect of negative feedback on

(i) Overall gain

(ii) Bandwidth

4AN: EC 404 (1480)

( 3 )

(Turn Over)

- (iii) Transient Response. 2 + 4 + 4 + 4
6. (a) Describe the following: 5 + 5
- (i) Nyquist Polar Plot
- (ii) Bode Plot.
- (b) What is Root Locus? 5
- (c) Using the Routh-Hurwitz criterion, determine  $K$  for which the closed-loop response is stable for a system with characteristic equation
- $$s^3 + 34 \cdot 5 s^2 + 7500 s + 7500 K = 0 \quad 5$$
7. (a) Explain briefly the action of the following controllers: 5 + 5
- (i) Proportional
- (ii) Proportional + Integral.
- (b) What is Rate-feedback control? What is the effect of the Derivative Feedback action on transient response? 6
- (c) What is steady state error? 4
8. (a) With a schematic diagram, describe the operation of a D.C. Servomechanism System with field control. 6
- (b) Derive the Transfer function of the system. 8
- (c) What is the minimum value of the Damping Factor ( $\delta$ ) for a 2nd-order system to have percent overshoot  $x < 10$ . 6

**Group C**

9. Indicate True (T)/ False (F) : 2 × 10
- (i) For a graph with  $n$  nodes, every Tree has  $(n - 1)$  branches.
- (ii) The response of a circuit is Time-Variant if given a signal  $x(t)$  and response  $y(t)$ , when the signal is  $x(t - T)$  the response is  $y(t - T)$ .
- (iii) A series RLC circuit is purely Reactive at the resonance frequency.
- (iv) The quality factor ( $Q$ ) is defined as
- $$Q = \frac{1}{2\pi} (\text{Total Energy Stored} / \text{Energy dissipated per cycle})$$
- (v) The function  $F(s) = (s + 3) / (s^2 + 3s + 5)$  is positive real.
- (vi) A system is stable if its closed-loop poles are on the RHS of the  $s$ -plane.
- (vii) A linear system obeys superposition theorem.
- (viii) Integral control action reduces steady state error.
- (ix) The final value  $y(t)$  of the step response of a single pole (at  $s = -a$ ) system is  $y(t) = a$ .
- (x) A Tachogenerator is a speed sensor.

**S'06 : 4 AN : EC 404 (1480)**

**CIRCUIT THEORY & CONTROL**

*Time : Three hours*

*Maximum Marks : 100*

*Answer FIVE questions, taking ANY TWO from Group A, ANY TWO from Group B and ALL from Group C.*

*All parts of a question (a, b, etc.) should be answered at one place.*

*Answer should be brief and to-the-point and be supplemented with neat sketches. Unnecessary long answers may result in loss of marks.*

*Any missing data or wrong data may be assumed suitably giving proper justification.*

*Figures on the right-hand side margin indicate full marks.*

**Group A**

1. (a) Formulate the equilibrium equations for the following circuits on the nodal basis: 4 + 8

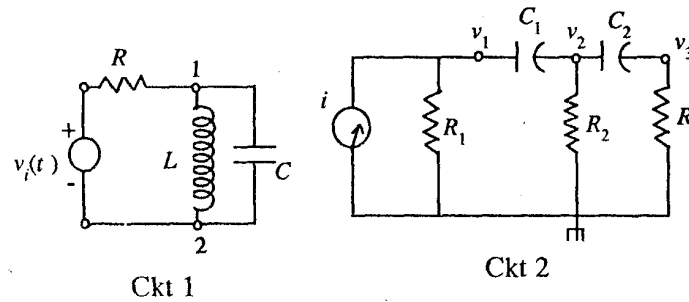

(Turn Over)

(b) Find the particular solution of the circuit shown below:

8

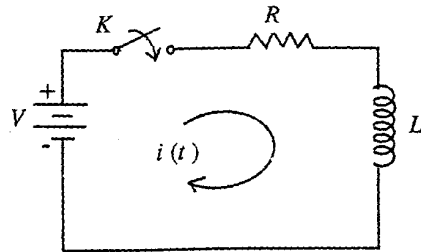

2. (a) Find the Fourier series of a square waveform given by

$$v(t) = \begin{cases} V, & 0 < t < T/4 \\ -V, & T/4 < t < 3T/4 \\ V, & 3T/4 < t < T \end{cases} \quad 12$$

(b) A capacitor  $C$  with initial voltage  $V_c(0^-)$  has current in the direction shown in the following figure. Find its transform representation in terms of impedance.

8

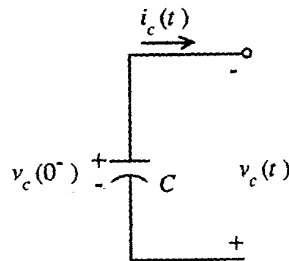

4AN:FC 404 (1480)

( 2 )

(Continued)

3. Draw a series resonance circuit and derive the expression for its resonant frequency. Draw its phasor diagrams and explain the resonance. Discuss the effect on the phasor of changing frequency. How do impedance and admittance vary with frequency? What is the effect of a small resistance in series with the circuit?

20

4. (a) Determine whether the following during point impedance function is a minimum function:

$$Z_0(s) = \frac{2s^4 + 3s^3 + 5s^2 + 5s + 1}{(s^2 + 1)(2s^2 + 2s + 4)} \quad 10.$$

(b) Explain the synthesis of Butterworth type Low Pass Passive filter. State the transfer function of this filter.

10

**Group B**

5. Draw a system which is electrical and can be expressed in terms of a second order differential equation write its differential equation. What is its response with the three dampings, namely, underdamped, critically damped and overdamped condition? Sketch the response, when the input is a step.

20

6. (a) Draw the schematic diagram of an armature controlled dc servomotor. Obtain its block diagram representation making allowable assumptions. State the assumptions.

10

(b) Draw the circuit diagram of two synchro connected for data transmission and explain the operation.

10

4AN:EC 404 (1480)

( 3 )

(Turn Over)

7. (a) The open loop transfer function for a type 2 unity feedback system is given by

$$G(s) = \frac{10(1+s)}{s^2(6+5s)}$$

Find the steady state error to an input

$$r(t) = 1 + 4t + 3t^2. \quad 10$$

- (b) Discuss the effect of variation of gain upon the steady state errors. 10

8. (a) Illustrate the stability condition for the system with characteristic equation

$$f(s) = s^6 + 3s^5 + 5s^4 + 9s^3 + 8s^2 + 6s + 4. \quad 12$$

- (b) Consider a characteristic equation of order 8

$$f(s) = a_0 s^8 + a_1 s^7 + a_2 s^6 + a_3 s^5 + a_4 s^4 + a_5 s^3 + a_6 s^2 + a_7 s + a_8$$

Deduce the relation between with array and Hurwitz determinants. 8

### Group C

9. Choose the *correct* answer: 2 x 10

- (i) The Euler's identity is given by

(a)  $e^{\pm j\omega t} = \sin \omega t \pm j \cos \omega t$

(b)  $e^{\pm j\omega t} = \cos \omega t \pm j \sin \omega t$

4AN:EC 404 (1480)

( 4 )

(Continued)

(c)  $e^{\pm j\omega t} = \sin \omega t \mp j \cos \omega t$

(d) none of the above.

- (ii) The time domain relationship between voltage and current for a capacitor is

(a)  $i_c(t) = \frac{1}{c} \frac{dv_c(t)}{dt}$

(b)  $i_c(t) = \frac{1}{c} \int_{-\infty}^t v_c(t) dt$

(c)  $i_c(t) = c \int_{-\infty}^t v_c(t) dt$

(d) none of the above.

- (iii) The Fourier series expansion of an even periodic function contains

(a) only cosine terms

(b) cosine terms and a constant

(c) only sine terms

(d) sine terms and a constant.

- (iv) The anti resonant circuit is a

(a) voltage amplifier

(b) transconductance amplifier

(c) current amplifier

(d) transresistance amplifier.

4AN:EC 404 (1480)

( 5 )

(Turn Over)

(v) While applying reciprocity theorem

- (a) initial conditions are taken into consideration
- (b) impedances are real quantities
- (c) admittances are real quantities
- (d) none of the above.

(vi) Linear systems obey

- (a) principle of maximum power transfer
- (b) reciprocity principle
- (c) principle of superposition
- (d) all of the above.

(vii)  $F^*(s)$  for  $f(t) = u(t)$  is

- (a)  $1 - e^{-sT}$
- (b)  $e^{-sT}$
- (c)  $\frac{1}{e^{-sT}}$
- (d)  $\frac{1}{1 - e^{-sT}}$

(viii) The auxilliary polynomial for a system with characteristic equation

$$f(s) = s^6 + s^5 + 3s^4 + 2s^3 + 11s^2 + 9s + 9 \text{ is}$$

- (a)  $4s^3 + 4s$
- (b)  $12s^2 + 4$

$$(c) s^4 + 2s^2 + 9$$

$$(d) s^5 + s^3 + 9s.$$

(ix) The differential transformer is

- (a) electrical transformer
- (b) mechanical transformer
- (c) non linear transformer
- (d) none of the above.

(x) The steady state error to an input  $r(t) = 1 + 4t + 3t^2$  applied to a type 2 unity feedback system having

$$G(s) = \frac{10(1+s)}{s^2(6+5s)} \text{ is}$$

- (a) 6.3
- (b) 0.63
- (c) 3.6
- (d) 0.36.

**W'06 : 4 AN : EC 404 (1480)****CIRCUIT THEORY AND CONTROL**

*Time : Three hours*

*Maximum Marks : 100*

*Answer FIVE questions, taking ANY TWO from Group A,  
ANY TWO from Group B and ALL from Group C.*

*All parts of a question ( a, b, etc. ) should  
be answered at one place.*

*Answer should be brief and to-the-point and be supplemented  
with neat sketches. Unnecessary long answers may  
result in loss of marks.*

*Any missing data or wrong data may be assumed suitably giving  
proper justification.*

*Figures on the right-hand side margin indicate full marks .*

**Group A**

1. (a) Define the following terms related to a network: 6
- (i) Branch;
  - (ii) Node;
  - (iii) Graph.
- (b) What is tree and write down the properties of trees. 6
- (c) Prove that the rank of a circuit matrix is  $(e - v + 1)$   
for a connected graph. 8



2. (a) Write down the mesh equation for the following network. Draw the graph of the network. Choose a tree and hence write its mesh equation. 12

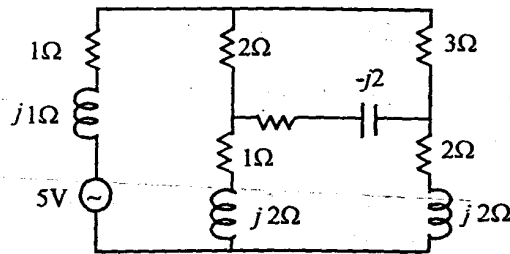

- (b) Evaluate the inverse Laplace transform of  $\left[ \frac{1}{(s+1)} \cdot \frac{1}{(s+2)} \right]$  making use of convolution theorem. 8

3. (a) Synthesize the first and second forms of Foster networks for the impedance function.

$$z(s) = \frac{(s+2)(s+5)}{(s+1)(s+4)} \quad 8$$

- (b) The impedances of series and shunt arm of an L network are  $j300\Omega$  and  $j700\Omega$  respectively. Calculate the image impedance. 6
- (c) A half section network has  $z_1 / z_2 = 100\Omega$  and shunt arm impedance  $2z_2 = 200\text{ohms}$ . Find the values of iterative impedance. 6

4. Write short notes on any two of the following: 10 x 2

- (i) Design of Butterworth low pass filter;
- (ii) Time domain behaviour from pole & zero plot;
- (iii) Q of a parallel resonant circuit;
- (iv) Initial and final value theorem.

**Group B**

5. (a) Discuss the merits and demerits of open loop and closed loop control system. 4

- (b) Mention any two important characteristics of each of the following types of control actions: 6

- (i) Proportional control;
- (ii) Integral control;
- (iii) Derivative control.

- (c) Obtain the root locus diagram of a discrete data control system with sample-and-hold and

$$G(s)H(s) = \frac{K}{s(s+1)} \text{ and } T = 1 \text{ sec.} \quad 10$$

6. (a) What is signal flow graph? Write down the basic properties of signal flow graph. 2 + 4

(b) Draw an equivalent signal flow graph for the block diagram shown below. Find the transfer function. 10

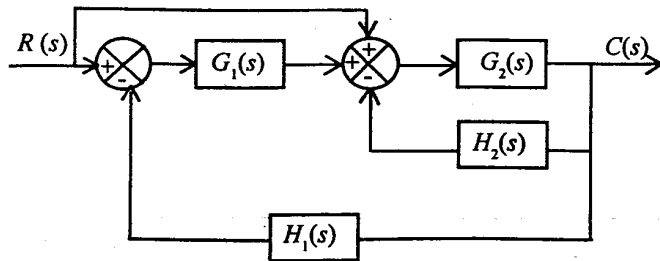

(c) What is steady state error? 4

7. (a) What is state diagram? In what way it is different from signal flow graph? 2 + 2

(b) Draw the state diagram of the following differential equation.

$$\frac{d^2 c}{dt^2} + 3 \frac{dc}{dt} + 2c = r$$

Also draw the analog computer block diagram of the system represented by above differential equation. 4 + 6

(c) Draw the state diagram of a system that is not observable. 6

8. Write short notes on any two of the following: 10 x 2

- (i) Nyquist polar plot and Bode plot;
- (ii) Transfer function of an armature control;
- (iii) PID controller design;
- (iv) Position and speed control system.

**Group C**

9. Choose the correct answers: 2 x 10

(i) To neglect a voltage source, the terminals across the source are

- (a) open circuited
- (b) short-circuited
- (c) replaced by some resistance
- (d) replaced by an inductor.

(ii) The Laplace transform of a unit impulse function is

- (a)  $1/S$
- (b)  $1/S^2$
- (c)  $1$
- (d)  $S$

(iii) The number of branches in a network is  $b$ , the number of nodes is  $n$  and the number of dependent loop is  $l$ . Then the number of independent current laws will be

(a)  $n + l - 1$

(b)  $b - l$ ;

(c)  $b - n$

(d)  $n - 1$ .

(iv) Pole of a network is a critical frequency at which

(a) network function becomes zero

(b) network function becomes infinite

(c) network function becomes unity

(d) none of these.

(v) An electrical network with 8 independent will have

(a) 8 nodal equations

(b) 7 nodal equations

(c) 9 nodal equations

(d) 4 nodal equations.

(vi) If a system is critically damped and the gain constant is increased, the system behaves as

(a) oscillatory

(b) underdamped

(c) overdamped

(d) none of these.

(vii) The Routh criterion tells us the number of roots lying

(a) in the left hand side of  $s$ -plane

(b) in the right half  $s$ -plane

(c) on the origin of the  $s$ -plane

(d) none of these.

(viii) Addition of zeros in a transfer function causes

(a) lead compensation

(b) lag compensation

(c) lead-lag compensation

(d) none of these.

(ix) For a stable feedback system; the phase margin

(a) is always positive

(b) is always negative

(c) may be positive or negative

(d) none of these.

(x) Damping in a control system is a function of

(a) Gain

(b)  $\sqrt{\text{Gain}}$

(c)  $1/\sqrt{\text{Gain}}$

(d)  $1/\text{Gain}$ .

**CIRCUIT THEORY AND CONTROL**

*Time : Three hours*

*Maximum Marks : 100*

*Answer FIVE questions, taking ANY TWO from Group A ,  
ANY TWO from Group B and ALL from Group C.*

*All parts of a question ( a, b, etc. ) should  
be answered at one place.*

*Answer should be brief and to-the-point and be supplemented  
with neat sketches. Unnecessary long answers may  
result in loss of marks.*

*Any missing or wrong data may be assumed suitably giving  
proper justification.*

*Figures on the right-hand side margin indicate full marks .*

*Semi-log graph sheets are permitted*

**Group A**

1. (a) How do you determine the cutset matrix of a given network graph? Consider the following network (Fig.1) and obtain the cutset matrix, taking the orientation of the graph as the direction of the currents in the elements.

Write the cutset equations.

2 + 6

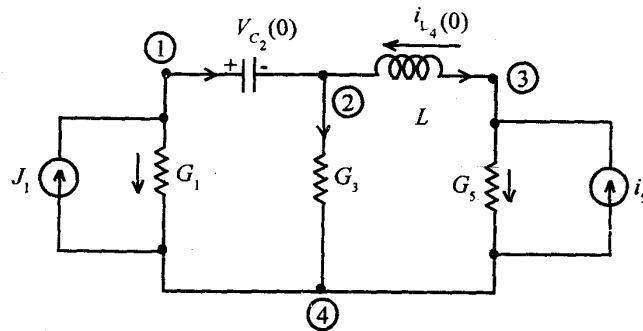

Fig.1

- (b) How do you identify the independent Mesh equations for any graph? 4
- (c) Prove the relation

$$Q_f Y_c Q_f^T V_b = -Q_f J_q, \text{ with the help of Lagrangian tree. } 8$$

- 2. (a) Determine the driving point impedances  $Z_{11}$ ,  $Z_{12}$  and  $Z_{22}$  for the following network: 6

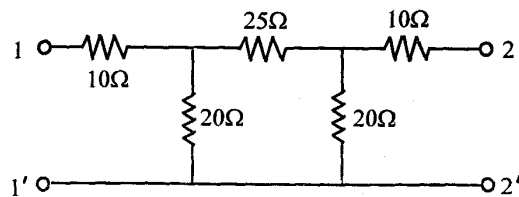

Fig. 2

- (b) A pair of coupled coils have a self-inductance of  $L_1$  and  $L_2$ , and mutual inductance  $M$ . If the energy delivered to a network from  $t_1$  to  $t_2$  is  $W(t_1) - W(t_2)$ , show that for the coupled coil

$$W(t) = 1/2 L_1 i_1^2 + 1/2 L_2 i_2^2 + M i_1 i_2.$$

where  $i_1$  and  $i_2$  are the two coil currents. Also, determine the condition under which  $W(t) \geq 0$  for all  $t$ . 8

- (c) What is an LTI system? How are the properties of an LTI system useful in the use of (i) Laplace transform, and (ii) Transfer function? 6

- 3. (a) In a parallel resonance circuit, where the elements  $R$ ,  $L$  and  $C$  are used, how will you draw a relationship of the quality factor with the damping factor  $\alpha$  and the damped natural frequency  $\omega_d$  in respect of pole zero configuration of the admittance of the said circuit? Express the bandwidth in terms of  $Q$  of the circuit. 14

- (b) What do you know about the frequency and impedance scaling of a circuit made of  $R$ ,  $L$  and  $C$ ? Justify the statement very briefly. 6

- 4. Write short notes on the following: 5 x 4

- (i) Tellegen's theorem
- (ii) Superposition theorem
- (iii) Reciprocity theorem
- (iv) Butterworth function for a low-pass filter.

**Group B**

5. (a) How do you distinguish between a linear and a non-linear system from the mathematical equations of the dynamics of the system? How are signal flow graphs used to relate input and output variables? 8
- (b) What are synchro control transformers? Explain its operation in brief. 6
- (c) How do you get a polarity sensitive torque in an a.c. servomotor? Explain with a diagram showing the arrangement of different windings. 6
6. (a) How do you use gyros for the measurement of (i) angular speed, and (ii) linear acceleration? 10
- (b) Show, with a neat diagram, a scheme for the control of speed of a d.c. motor drive. 10
7. (a) Apply Routh-Hurwitz criterion to comment on the stability of systems whose characteristic equations are given below: 5+5
- (i)  $S^4 + 5S^3 + 4S^2 + 3S + 6$
- (ii)  $3S^5 + 7S^4 + S^3 + 2S^2 + 3S$
- (b) Sketch the Bode gain and phase plots for the following transfer function: 5+5
- $$G(S) = 100 (S + 100)^2 / S(S + 400).$$

8. (a) Explain in brief the contribution of  $P$ ,  $I$  and  $D$  components of a PID controller in a process. If the gain in the derivative channel  $K_D$  is reduced. What are the possible effects on the output quality? 6
- (b) How do you estimate the steady state errors of a system with a given transfer function? 4
- (c) Sketch the polar plot (Nyquist plot) for the open loop transfer function

$$G(S) = \frac{K}{S(1 + 5S)(1 + 20S)}$$

and obtain the limits on the values of  $K$  for the stability of the closed loop system. 10

**Group C**

9. Choose the *correct* answer for the following: 2x10
- (i) In second order linear control system, the output response for unity damping factor will be
- (a)  $1 + e^{w_n t} + W_n t e^{-w_n t}$
- (b)  $1 - e^{-w_n t}(1 + W_n t)$
- (c)  $1 - e^{w_n t} + W_n t e^{-w_n t}$
- (d) None of the above.
- (ii) To reduce steady state error of the control system, increase its
- (a) time constant
- (b) gain constant

- (c) damping frequency
- (d) All of the above.
- (iii) The eigenvalues of a linear system are the location of
- (a) poles of the system
- (b) zeros of the system
- (c) both (a) and (b) above
- (d) finite poles and zeros.
- (iv) The resolution of a potentiometer should be
- (a) infinite
- (b) very high
- (c) medium
- (d) zero.
- (v) The ratio of damped frequency to natural frequency of the given system having damping factor  $\xi$  is
- (a)  $1/\eta$
- (b)  $\xi$
- (c)  $\xi^2$
- (d)  $\sqrt{1-\xi^2}$ .

- (vi) The impedance functions of passive elements are given below:

$$(A) \frac{s(s+4)}{(s+2)(s+6)}, \quad (B) \frac{s(s^2+4)}{(s^2+1)(s^2+9)},$$

$$(C) \frac{(s+4)(s+20)}{s(s+16)}$$

Indicate the correct statement.

- (a) (A), (B), (C) are R-C, L-C and R-L networks, respectively
- (b) (A), (B), (C) are L-C, R-L and R-C networks, respectively
- (c) (A), (B), (C) are L-C, R-C and R-L networks, respectively
- (d) (A), (B), (C) are R-L, L-C and R-C networks, respectively.
- (vii) The corner frequencies of a system having transfer function as  $\frac{100(1+0.2s)}{(1+0.5s)}$  are
- (a) 0.2 and 0.5
- (b) -0.2 and -0.5
- (c) 5 and 2
- (d) None of the above.
- (viii) For a control system having gain margin of -10 dB, the magnitude of  $GH(S)$  for  $180^\circ$  phase shift is
- (a) 10 dB



(b) 1/10 dB

(c) -1/10 dB

(d) -10 dB.

(ix) If the source impedance of a constant voltage source is  $R_i + jX_i$  and the load impedance is  $R_L + jX_L$ , and if only  $R_L$  can be varied, then for maximum power to be delivered at the load,

(a)  $R_L = R_i$ (b)  $R_L = (R_i^2 + X_i^2)^{1/2}$ (c)  $R_L = [R_i^2 + (X_L + X_i)^2]^{1/2}$ (d)  $R_L = R_i + |X_L + X_i|$ .

(x) For a  $\pi$  network with admittances  $Y_A$  and  $Y_B$  as shunt arms and  $Y_C$  as the series arms, the values of  $Y_{11}$ ,  $Y_{12}$  and  $Y_{22}$  will be respectively

(a)  $(Y_A + Y_C)$ ,  $Y_B$ ,  $Y_C$ (b)  $(Y_A + Y_C)$ ,  $-Y_C$ ,  $(Y_B + Y_C)$ (c)  $Y_A$ ,  $(Y_B + Y_C)$ ,  $-Y_B$ (d)  $Y_A$ ,  $-Y_C$ ,  $Y_B$ .

**CIRCUIT THEORY AND CONTROL***Time : Three hours**Maximum Marks : 100*

*Answer FIVE questions, taking ANY TWO from Group A,  
ANY TWO from Group B and ALL from Group C.*

*All parts of a question (a, b, etc.) should  
be answered at one place.*

*Answer should be brief and to-the-point and be supplemented  
with neat sketches. Unnecessary long answer may  
result in loss of marks.*

*Any missing or wrong data may be assumed suitably giving  
proper justification.*

*Figures on the right-hand side margin indicate full marks.*

**Group A**

1. (a) Write down the mesh equation for the following network (Fig.1). Draw the graph of the network. Choose a tree and hence write its mesh equation. Calculate the current in  $5\Omega$  resistor. 10

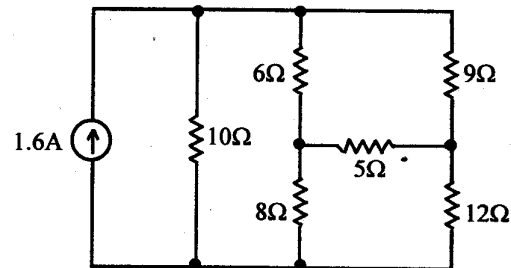
*Fig. 1*

(b) Determine the values (magnitude and angle) of the phasor voltages  $\bar{V}_1$  and  $\bar{V}_2$  (Fig.2) : 10

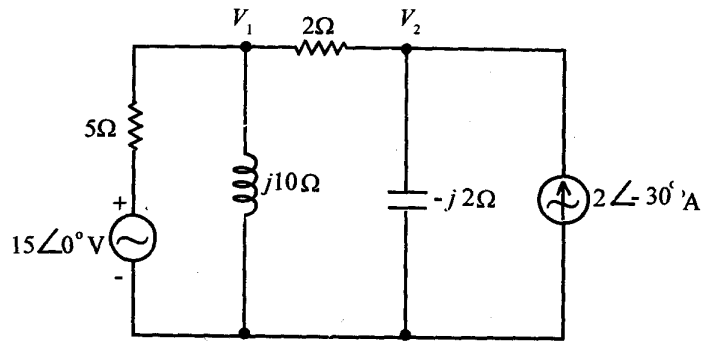

Fig. 2

2. (a) Find the Laplace transform of the following functions : 7

(i)  $t u(t)$  (unit ramp function)

(ii)  $t e^{-at} u(t)$

(iii)  $\sin h(bt) u(t)$ .

(b) Obtain the inverse Laplace transform of the following : 7

$$\frac{12(s+2)}{s(s^2+4s+8)}$$

(c) Explain the initial and final value theorems. 6

3. (a) Synthesize the first and second forms of Foster networks for the impedance function 8

$$z(s) = \frac{(s+2)(s+5)}{(s+1)(s+4)}$$

S'08 :4AN :EC404(1480)

( 2 )

(Continued)

(b) A half section network has  $z_1/z_2 = 100 \Omega$  and shunt arm impedance  $2z_2 = 200$  ohms. Find the values of iterative impedance. 6

(c) The impedances of series and shunt arm of an L network are  $j300 \Omega$  and  $j700 \Omega$ , respectively. Calculate the image impedance. 6

4. (a) Explain Bode plot and the time domain behaviour from pole and zero plot in S plane for a transfer function. 6

(b) Draw and explain a Bessel type low-pass filter circuit and its frequency characteristics. 7

(c) Draw the all pass, band pass and band rejection filters. Explain characteristics and operations of these filters. 7

**Group B**

5. (a) Summarize basic properties of signal flow graphs with the help of a neat diagram. 7

(b) Consider a typical control system to illustrate how the signal flow graph and block diagram are related. Draw two equivalent representations of the control system considered. 8

(c) Discuss the merits and demerits of open loop and closed loop control system. 5

S'08 :4AN :EC404(1480)

( 3 )

(Turn Over)

6. (a) Figure.3 shows the diagram of a motor coupled to an inertial load through a shaft with a spring constant  $K$ . A non-rigid coupling between two mechanical components in a control system often causes torsional resonances that can be transmitted to all parts of the system. Draw the state diagram of the system. 10

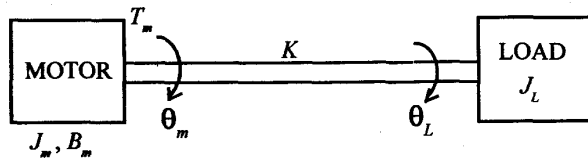

Fig. 3

- (b) Draw and explain an a.c. control system employing synchro error detector with typical waveforms of signals in the control system. 10
7. (a) Draw the d.c. motor position control system with potentiometers as error sensors. Explain typical waveforms of signals in this control system. 10
- (b) Draw a typical unit-step response of a control system and explain maximum overshoot, delay time, rise time and settling time. 6
- (c) Explain the terms 'error coefficients' and 'steady state error'. 4

8. Write short notes on any two of the following : 10x2
- (i) Routh-Hurwitz criterion
- (ii) Polar plots and Bode plots
- (iii) PI controllers
- (iv) PID controllers.

## Group C

9. Choose the correct answer for the following : 1x20
- (i) An electric circuit contains
- (a) active elements only
- (b) passive elements only
- (c) Both active and passive elements
- (d) None of the above.
- (ii) A linear circuit is one whose parameters (eg., resistances, etc.)
- (a) change with change in current
- (b) change with change in voltage
- (c) do not change with voltage and current
- (d) None of the above.

(iii) Current in a single loop can be obtained by applying

- (a) Ohm's law
- (b) Kirchhoff's voltage law
- (c) Kirchhoff's current law
- (d) Ohm's law and Kirchhoff's voltage law.

(iv) Current division shows that current divides among parallel resistors in..... proportion to the resistance path

- (a) inverse
- (b) direct
- (c) equal
- (d) None of the above.

(v) The resistance is infinite, the current is zero and voltage across terminals is determined by the rest of the circuit for

- (a) short circuit
- (b) open circuit
- (c) infinite resistance connected
- (d) None of the above.

(vi) Semilog plots of the magnitude and phase of transfer functions as a function of frequency are

- (a) Nyquist plot
- (b) Bode plot
- (c) Polar plot
- (d) Root locus plot.

(vii) The frequency at which the impedance of a series RLC circuit or the admittance of a parallel RLC circuit is purely real is

- (a) resonant frequency
- (b) critical frequency
- (c) base band frequency
- (d) quality factor.

(viii) The bandwidth of this filter is defined as the difference in frequency between the half power points

- (a) Low pass
- (b) High pass
- (c) Band rejection
- (d) None of the above.

(ix) To convert a problem from time domain to the complex frequency domain and solve the problem using algebra in  $S$  domain is called

- (a) Fourier series
- (b) Frequency response
- (c) Laplace transform
- (d)  $Z$ -transform.

(x) Convolution integral can be used to determine

- (a) Laplace transform
- (b) Inverse Laplace transform
- (c) Initial and final value of time domain function
- (d) Integro-differential equations.

(xi) Signal flow graph applied to dynamic systems and represented by differential equations are

- (a) transfer functions
- (b) Block diagram
- (c) State diagram
- (d) None of the above.

(xii) To find whether or not these have unstable roots in a polynomial equation without actually solving for them, we use

- (a) Routh's-Hurwitz criterion
- (b) Bode plots
- (c) Nyquist stability criterion
- (d) Laplace transform.

(xiii) The proportional control is not used alone because it produces a constant

- (a) steady state error
- (b) damping
- (c) peak overshoot
- (d) transient error.

(xiv) To eliminate the reduction in velocity error constant ( $K_v$ ), in rate feedback connect in cascade with rate device a

- (a) Low-pass filter
- (b) High-pass filter
- (c) Band-pass filter
- (d) Band rejection filter.

(xv) The addition of a zero to open transfer function will improve

- (a) frequency response
- (b) time response
- (c) transient response
- (d) steady state error.

(xvi) A device inserted into the system for satisfying the specifications is called

- (a) controller
- (b) regulator
- (c) feedback device
- (d) compensator.

(xvii) The lag compensator will reduce the \_\_\_\_\_ of the system which will result in slower \_\_\_\_\_ response

- (a) transient, bandwidth
- (b) bandwidth, transient
- (c) speed, frequency
- (d) stability, time.

(xviii) In system subjected to frequent load disturbances the compensation preferred is

- (a) feedback
- (b) lead
- (c) lag
- (d) lag-lead.

(xix) The set of all possible values which the state  $x(t)$  can assume at a time to form the \_\_\_\_\_ of the system

- (a) state variables
- (b) state space
- (c) state model
- (d) state diagram.

(xx) The frequency response plot of the open loop transfer function of a system is called

- (a) Nichols plot
- (b) Polar plot
- (c) Bode plot
- (d) Nyquist plot.

**CIRCUIT THEORY AND CONTROL***Time : Three hours**Maximum Marks : 100*

*Answer FIVE questions, taking ANY TWO from Group A ,  
ANY TWO from Group B and ALL from Group C.*

*All parts of a question ( a, b, etc. ) should  
be answered at one place.*

*Answer should be brief and to-the-point and be supplemented  
with neat sketches. Unnecessary long answer may  
result in loss of marks.*

*Any missing or wrong data may be assumed suitably giving  
proper justification.*

*Figures on the right-hand side margin indicate full marks .*

**Group A**

1. (a) For the given graph, shown in Fig. 1 , write the cut-set schedule and obtain the relation between tree branch voltages and branch voltages. Select  $a$ ,  $b$ ,  $c$  as the branches of the tree. 6

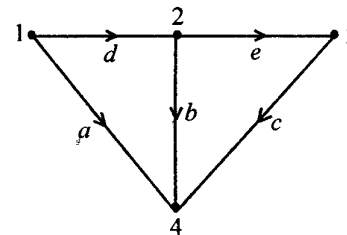

Fig. 1



- (b) Find the power delivered by the 5 A current source in the circuit shown in Fig. 2 by using nodal method. 7

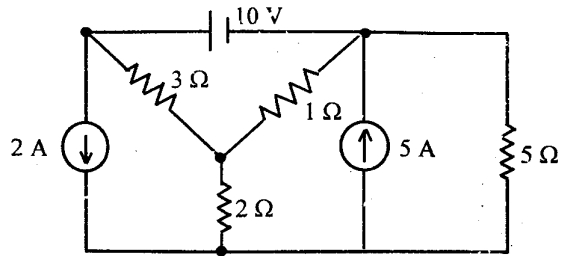

Fig. 2

- (c) Find the inverse Laplace transform of the following: 7

$$X(s) = 1/(s^2 + 5^2)^2$$

2. (a) In the network shown in Fig. 3, determine  $V_1$  and  $V_2$ . 10

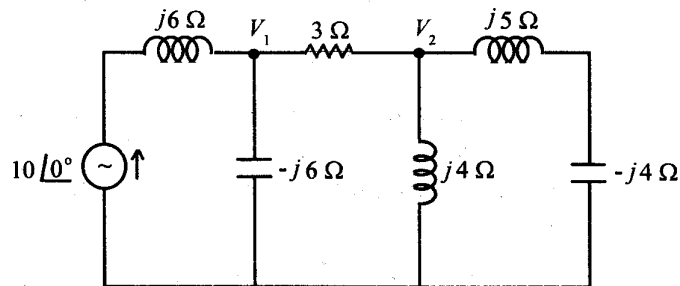

Fig. 3

- (b) Find the convolution of 10

$$x(t) = \begin{cases} 1, & 0 \leq t \leq 2 \\ 0, & \text{otherwise} \end{cases}$$

with

$$h(t) = \begin{cases} t, & \text{for } 0 \leq t \leq b \\ 0, & \text{otherwise} \end{cases}$$

3. (a) Find the trigonometric Fourier series for the half-wave rectified sine wave signal. 10

- (b) For the following network function, draw the pole zero diagram and hence obtain the time domain response for an impulse input: 10

$$V(s) = \frac{5s}{(s+1)(s^2+4s+8)}$$

4. (a) State the restrictions on pole and zero locations in driving point function and transfer function. 7

- (b) A series RLC circuit consists of 50 Ω resistance, 0.2 H inductance and 10 μF capacitor with the applied voltage of 20 V. Determine the resonant frequency. Find the Q-factor of the circuit. Compute the lower and upper half power frequencies and also find the bandwidth of the circuit. 7

- (c) Explain the properties of Butterworth and Chebyshev filters with a neat sketch of magnitude responses. 6

**Group B**

5. (a) Explain open-loop and closed-loop control systems with an example of each. 6

- (b) Draw the signal flow graph and find out the transfer function of the circuit shown in Fig. 4. 8

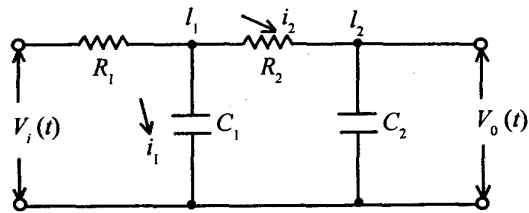

Fig. 4

- (c) The characteristic equation of a feedback control system is given by

$$s^3 + 2ks^2 + (k + 2)s + 4 = 0.$$

Using Routh-Hurwitz criterion, determine the range of values of  $k$  for the system to be stable. 6

6. (a) With a neat diagram, explain the construction and working principle of synchro transmitter. 8
- (b) Obtain the unit step response of a unity feedback system whose open-loop transfer function is given by  $G(s) = 4/[s(s + 5)]$ . 8
- (c) Explain, with a neat schematic diagram, the principle of a.c. tachogenerators. 4
7. (a) The open-loop transfer function of a unity feedback system is given by.

$$G(s) = \frac{108}{s^2(s + 4)(s^2 + 3s + 12)}$$

Find the static error coefficients and steady state error of the system when subjected to an input given by

$$r(t) = 2 + 5t + 2t^2. \quad 8$$

- (b) A feedback system is described by the following transfer function :

$$G(s) = \frac{12}{s^2 + 4s + 16}, \quad H(s) = Ks.$$

The damping factor of the system is 0.8. Determine the overshoot of the system and the value of  $K$ . 8

- (c) What are frequency domain specifications ? Explain. 4

8. (a) Sketch the polar plot for 8

$$G(s) = \frac{20}{s(s + 1)(s + 2)}$$

- (b) Draw the block diagram of feedback system with PI controller and explain the effect of PI controller. 5

- (c) Find the transfer function of the given Bode plot shown in Fig. 5: 7

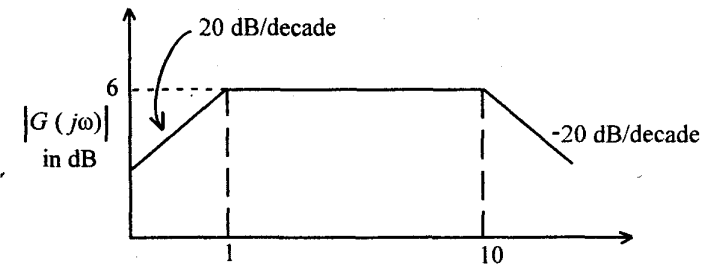

Fig. 5

**Group C**

9. Choose the *correct* answer for the following: 1 × 20

(i) The cut-set schedule gives the relation between

- (a) branch currents and link currents
- (b) branch voltages and tree branch voltages
- (c) branch voltages and link voltages
- (d) branch currents and tree currents.

(ii) If a network contains  $B$  branches and  $N$  nodes, then the number of independent mesh current equations would be

- (a)  $B - N + 1$
- (b)  $N - B + 1$
- (c)  $B - N - 1$
- (d)  $B + N - 1$ .

(iii) The Laplace transform of a unit step function is

- (a)  $1/s$
- (b) 1
- (c)  $1/s^2$
- (d)  $1/(s+1)$ .

(iv) The Laplace transform of first derivative of a function  $x(t)$  is

- (a)  $X(s)/s$
- (b)  $sX(s) - x(0)$
- (c)  $X(s) - x(0)$
- (d)  $X(s)$ .

(v) Convolution integral of two rectangular pulse of equal width results a ——— signal.

- (a) rectangular
- (b) triangular
- (c) trapezoidal
- (d) sinusoidal.

(vi) If  $C_K$  is the exponential Fourier coefficient of a periodic signal,  $x(t)$ , then the Fourier coefficient of  $x(-t)$  is

- (a)  $C_K$
- (b)  $-C_K$
- (c)  $C_{-K}$
- (d)  $-C_{-K}$ .

(vii) What is the phase angle between the inductor current and the applied voltage in a parallel RL circuit?

- (a) 0

(b)  $45^\circ$ (c)  $90^\circ$ (d)  $30^\circ$ .

(viii) The two port network is reciprocal if

(a)  $Z_{12} = Z_{21}$ (b)  $Z_{11} = Z_{22}$ (c)  $h_{12} = h_{21}$ (d)  $A = B$ .(ix) In a series RLC circuit, if  $C$  is increased, what happens to the resonant frequency?

(a) increases

(b) decreases

(c) remains the same

(d) becomes zero.

(x) The function is said to be positive real when the

(a) poles and zeros lie on right half of the  $s$ -plane.(b) poles and zeros lie on left half of the  $s$ -plane.

(c) poles and zeros are simple and lie on the imaginary axis.

(d) Both (b) and (c) above.

(xi) Signal flow graph is applicable to

(a) linear system.

(b) non-linear system.

(c) both (a) and (b) above.

(d) None of the above.

(xii) The effect of feedback will ——— the system stability and ——— the distortion.

(a) increase, increase

(b) increase, decrease

(c) decrease, increase

(d) decrease, decrease.

(xiii) The transfer function of the tachogenerator is ——— (if  $k$  is the sensitivity of the tachogenerator).(a)  $k/s$ (b)  $k/s^2$ (c)  $ks$ (d)  $ks^2$ .(xiv) The closed-loop transfer function of second order system is  $10/(s^2 + 6s + 10)$ . What is the type of damping in the system?

- (b) undamping
- (c) critically damping
- (d) overdamping.
- (xv) The steady state error of type 1 system for step input is
- (a)  $\infty$
- (b)  $1/k_s$
- (c) 0
- (d)  $k_s$ .
- (xvi) The addition of pole to the system transfer function will ——— the rise time and ——— the overshoot.
- (a) decrease, increase
- (b) decrease, decrease
- (c) increase, decrease
- (d) increase, increase.
- (xvii) Derivative control action will
- (a) reduce the steady state error.
- (b) reduce the rise time.
- (c) increase the rise time.
- (d) Both (a) and (b) above.
- (xviii) The system is stable, if the point
- (a)  $(-1 + j0)$  is within the polar plot.
- (b)  $(-1 + j0)$  is outside the polar plot.
- (c)  $(1 + j0)$  is within the polar plot.
- (d)  $(1 + j0)$  is outside the polar plot.
- (xix) The number of sign changes in the elements of the first column of the Routh array corresponds to the number of roots of the characteristics equation in the
- (a) right half of the  $S$ -plane
- (b) left half of the  $S$ -plane
- (c) imaginary axis
- (d) None of the above.
- (xx) The phase cross-over frequency is the frequency at which the phase angle is
- (a) 0
- (b)  $90^\circ$
- (c)  $45^\circ$
- (d)  $180^\circ$ .

**S'09 : 4AN : EC404 (1480)****CIRCUIT THEORY AND CONTROL***Time : Three hours**Maximum Marks : 100*

*Answer FIVE questions, taking ANY TWO from Group A,  
ANY TWO from Group B and ALL from Group C.*

*All parts of a question ( a,b,etc.) should  
be answered at one place.*

*Answer should be brief and to-the-point and be supplemented  
with neat sketches. Unnecessary long answer may  
result in loss of marks.*

*Any missing or wrong data may be assumed suitably giving  
proper justification.*

*Figures on the right-hand side margin indicate full marks.*

**Group A**

1. (a) A coil of inductance  $L$  and resistance  $R$  is in parallel with a capacitor of capacitance  $C$ . Show that the resonance frequency is 4

$$f_0 = \frac{1}{2\pi} \sqrt{\frac{1}{LC} - \frac{R^2}{L^2}}$$

- (b) Write the node voltage equations and determine the

( Turn Over )

currents in each branch for the network shown in Fig. 1.

7

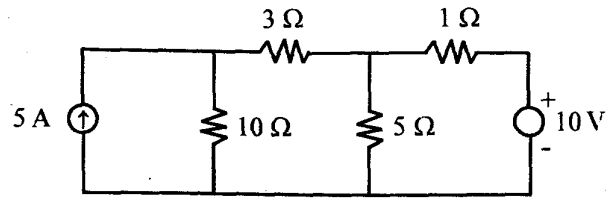

Fig. 1

(c) Define the short-circuit impedance parameters. Why are the parameters called short-circuit impedance parameters? Find  $y$ -parameters for the resistive network of Fig. 2.

9

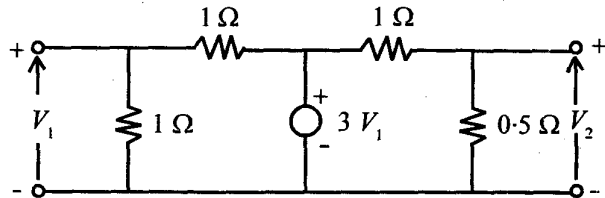

Fig. 2

2. (a) Define the ABCD parameters. Prove that the ABCD parameter matrix for the overall network is simply the matrix product of transmission parameter matrices of each of the two-port networks in cascade.

6

(b) In the given network (Fig. 3), making use of superposition theorem, determine currents in the

resistors  $R_1$ ,  $R_2$ , and  $R_3$ , and also current in the voltage source  $E$ .

4

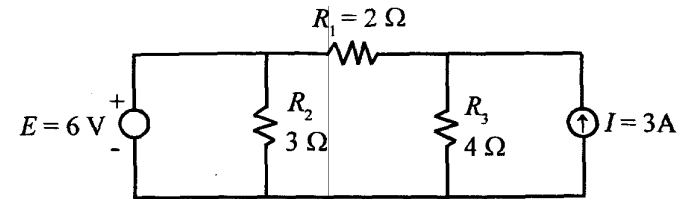

Fig. 3

(c) Derive the Laplace transform of the function  $f(t) = t$ .

2

(d) A staircase voltage,  $v(t)$ , shown in Fig. 4, is applied to an  $R$ - $L$  network consisting of  $L = 1 H$  and  $R = 2\Omega$ . Write an equation for the staircase voltage in terms of step function. Find the Laplace transform of  $v(t)$ . Find the current  $i(t)$  in the circuit. Draw the waveform of current  $i(t)$ . Assume zero current through the inductor  $L$  before applying the voltage.

8

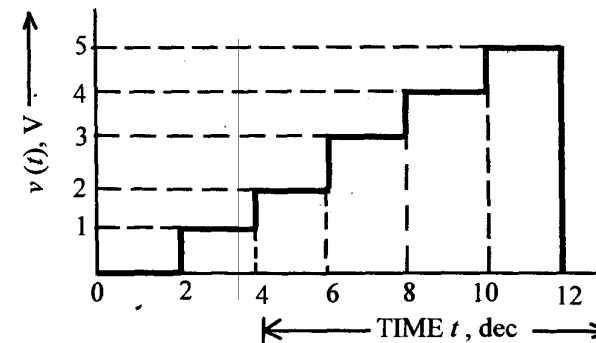

Fig. 4

3. (a) Explain, with the help of any graph, the connected graph and unconnected graph. For the given resistive network (Fig. 5), draw the graph and 10 possible trees.

6

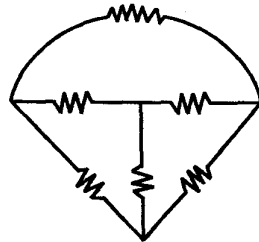

Fig. 5

- (b) The driving point impedance of an L-C network is given by

$$Z(s) = \frac{(s^2 + 1)(s^2 + 3)}{s(s^2 + 2)}$$

Determine the first and second Cauer forms of the network.

8

- (c) In the given network (Fig. 6), switch  $K$  is opened at time  $t = 0$ , the steady-state having established previously. With switch  $K$  open, draw the transform (s-domain) network representing all elements and all initial conditions. Write the transform equation for current in the loop. From that expression, also find the current  $i(t)$  in the loop.

6

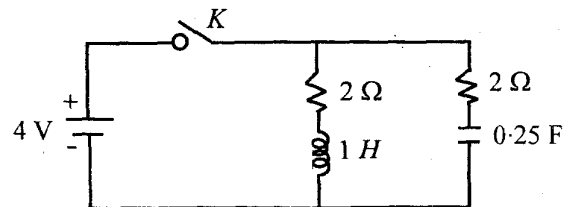

Fig. 6

S'09 : 4AN : EC404 (1480)

( 4 )

( Continued )

4. (a) Find the exponential Fourier series expansion of the square wave shown in Fig. 7.

6

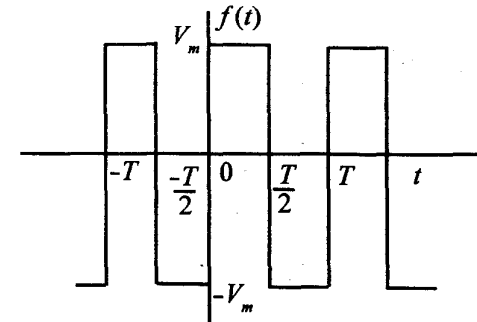

Fig. 7

- (b) Prove that the Laplace transform of any time function  $f(t)$  delayed by time  $a$  is  $e^{-as}$  times the transform of the function  $F(s)$ .

3

- (c) A step d.c. voltage of 8 V is applied at time  $t = 0$  to a series R-L-C circuit consisting of a resistor of 4 ohm, inductor  $L = 1$  Henry and capacitor  $C = 0.25$  farad. Write the integro-differential equation by applying Kirchhoff's voltage law to this circuit. From this, find the Laplace transform equation. Obtain the equation for the current  $i(t)$  through the circuit with the help of Laplace transform. Assume zero current through inductor  $L$  and zero voltage across the capacitor  $C$  before switching.

5

- (d) A series R-L-C circuit consists of a resistance  $R = 10 \Omega$ , inductance  $L = 0.2$  H and capacitance  $C = 0.2 \mu\text{F}$ . Calculate the frequency of resonance. A 10 V sinusoidal voltage at the frequency of

S'09 : 4AN : EC404 (1480)

( 5 )

( Turn Over )



resonance is applied across the circuit. Draw the phasor diagram showing the value of each phasor. Also, calculate the value of current when 10 V, 850 Hz voltage is applied to the circuit.

6

**Group B**

5. (a) What do you understand by a control system? Explain the difference between an open-loop and a closed-loop control system. Distinguish between a negative feedback and a positive feedback control system. What is a unity feedback control system? 6
- (b) How do you determine gain margin and phase margin from Bode plots? Explain with the help of typical plots. 5
- (c) Determine the transfer function of the system represented by a block diagram shown in Fig. 8. 4

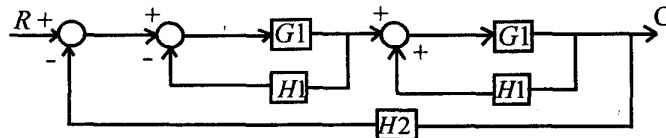

Fig. 8.

- (d) Refer to the block diagram representation of Fig. 9, determine the system characteristic equation. Is the system represented by this block stable? Justify your answer. 5

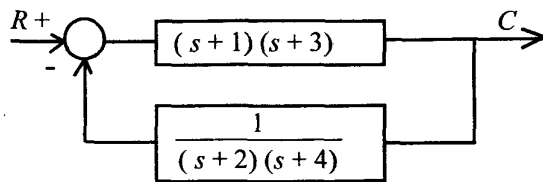

Fig. 9

S'09 : 4AN : EC404 (1480) ( 6 )

( Continued )

6. (a) With reference to control systems, briefly explain the following : 3
- (i) Steady state response,
  - (ii) Transient response, and
  - (iii) Unit impulse response.

- (b) Design a PID controller, using operational amplifier, and express proportional gain, integral gain and derivative gain in terms of network elements. 6

- (c) Determine the damping ratio ( $\zeta$ ), undamped natural frequency ( $\omega_n$ ), damped natural frequency ( $\omega_d$ ), time constant ( $\tau$ ), settling time ( $t_s$ ) and percentage overshoot in case of a second order control system represented by the differential equation 6

$$\frac{3d^2y}{dt^2} + \frac{6dy}{dt} + 12y = 12x.$$

- (d) What do you understand by stability of a control system? The characteristic equation of a given system is

$$s^3 + (K + 4)s^2 + 6s + 12 = 0$$

With the help of Routh stability criterion, determine the values of K for which the system would be stable. 5

7. (a) What do you understand by the transfer function of a control system? How can you determine system poles, system zeros and the characteristic equation from the system transfer function? 4

S'09 : 4AN : EC404 (1480) ( 7 )

( Turn Over )

(b) What do you mean by signal flow graphs ? Explain with some examples. Write the expression for the general Mason's gain formula. Interpret each term of the expression. 6

(c) Determine the gain and phase margins for a system with the open-loop transfer function given by  $GH = 2/(s + 1)$ . 4

(d) Determine the transfer function of the system represented by the differential equation 2

$$\frac{d^2y}{dt^2} + \frac{dy}{dt} + 3y = \frac{dx}{dt} + 2x.$$

(e) Determine the system differential equation from the system transfer function  $H(s) = (s + 1)(s + 3) / [s(s + 2)(s + 4)]$ . 4

8. (a) What do you mean by d.c. and a.c. close-loop servomechanisms ? Draw the schematic diagram of a d.c. closed-loop system and also draw its block diagram with usual gain. Derive the algebraic and differential equations with the application of some input and find the overall transfer function of the system. 9

(b) Write short notes on : (i) Synchros, and (ii) Tachogenerators. 6

(c) Draw the signal flow graph for the block diagram

S'09 : 4AN : EC404 (1480) ( 8 )

( Continued )

shown in Fig. 10. Determine the system transfer function by use of the Mason's gain formula : 5

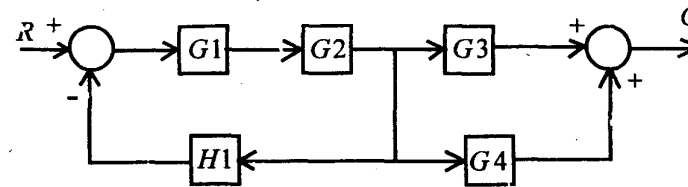

Fig. 10

**Group C**

9. Choose the correct answer for the following : 2 x 10

(i) The driving point impedance of a network can be calculated from

- (a)  $\Delta z / \Delta_{11}$
- (b)  $\Delta y / \Delta_{11}$
- (c)  $\Delta_{11} / \Delta z$
- (d)  $\Delta_{11} / \Delta y$
- (e) None of the above.

Terms have their usual meaning.

(ii) When we talk about node voltage analysis, using matrix formulation, it is

- (a) impedance matrix
- (b) admittance matrix
- (c) z-parameters
- (d) Laplace transform
- (e) None of the above.

S'09 : 4AN : EC404 (1480) ( 9 )

( Turn Over )

- (iii) A resistance of  $10\ \Omega$  in parallel with a reactance of  $(j10)\ \Omega$  shall have a phase angle
- $45^\circ$
  - $60^\circ$
  - $0^\circ$
  - $30^\circ$
  - $90^\circ$
- (iv) The maximum power that can be transferred to an external resistive load from a 10 V battery, with an internal resistance of  $1\ \Omega$ , is
- 25 W
  - 100 W
  - 10 W
  - indeterminate from given data
  - None of the above.
- (v) A function  $f(t)$  is an even function, if for all values of  $(t)$ ,
- $f(t) = f(-t)$
  - $f(t) = -f(-t)$
  - $f(t) = f(t + T)$
  - $f(t) = -f(t + T/2)$
  - $f(t) = -f(t + T)$
- (vi) A negative feedback control system is characterized by
- reduced bandwidth
  - increased accuracy
  - increased non-linearity
  - reduced distortion.
- (vii) Free response of a control system is the one characterized by
- input approaching infinity with time
  - input being a finite value
  - zero input
  - all initial conditions being zero.
- (viii) A causal system is the one in which the output depends upon
- input as well as output
  - present and past inputs
  - present as well as future inputs
  - present and past inputs and past outputs.
- (ix) One of the following methods can be used to determine only the absolute stability of a control system :
- Routh stability criterion
  - Root locus analysis
  - Bode plots
  - Nichols charts and plots.
- (x) A higher value of gain factor ( $K$ ) at the imaginary axis cross-over of the root locus plot of a control system
- brings it closer to instability
  - takes it farther from instability
  - is always undesirable
  - None of the above.

**W'09 : 4 AN : EC 404 (1480)****CIRCUIT THEORY AND CONTROL***Time : Three hours**Maximum Marks : 100*

*Answer FIVE questions, taking ANY TWO from Group A ,  
ANY TWO from Group B and ALL from Group C .*

*All parts of a question ( a, b, etc. ) should  
be answered at one place.*

*Answer should be brief and to-the-point and be supplemented  
with neat sketches. Unnecessary long answers may  
result in loss of marks.*

*Any missing or wrong data may be assumed suitably giving  
proper justification.*

*Figures on the right-hand side margin indicate full marks .*

**Group A**

1. (a) What do you understand by the terms 'tree' and 'cutset' of a network graph? How do you determine the cutset matrix for a network graph after selecting a tree? Explain with the help of an example. 10
- (b) Show a connected network graph for the following circuit (Fig. 1) and three possible trees. Also, show

a loop matrix  $B$ .

10

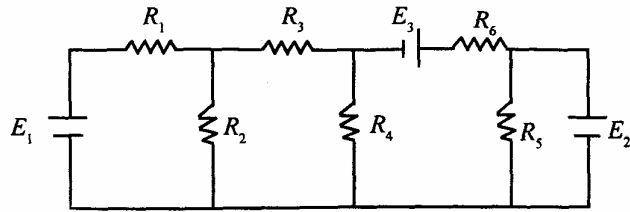

Fig.1

2. (a) For the network function, shown in Fig. 2, determine the driving point impedance and sketch the poles and zeros in the S-plane. 10

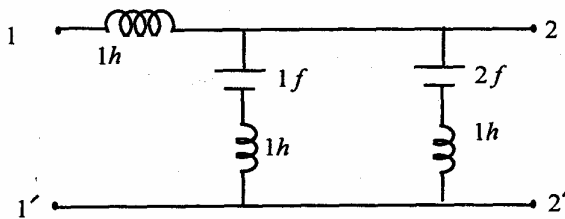

Fig. 2

- (b) How do you estimate the impulse response of a network function from its pole-zero plot? Write the expression for the impulse response for the given pole-zero pattern (Fig. 3): 10

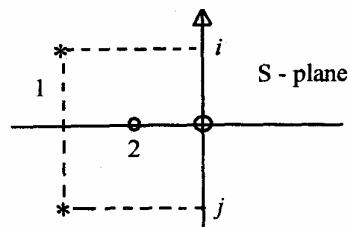

Fig. 3

3. (a) Determine the  $y$ -parameters (short-circuit parameters) of the circuit shown in Fig. 2. 8

- (b) Determine the Laplace transform of the following periodic function: 8

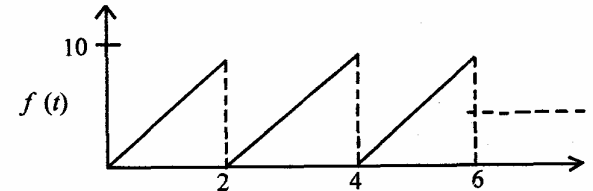

Fig. 4

- (c) If the above waveform of a voltage is applied to the following R-C circuit (Fig. 5), what will be the nature of the current? 4

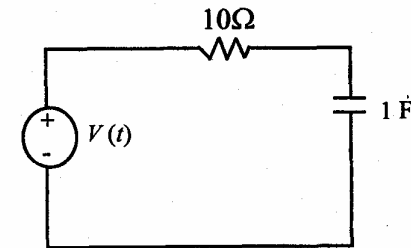

Fig. 5

4. (a) State clearly how from a given filter specification (for low pass), a Butterworth filter is designed. Mention how the order is selected. 15

- (b) The specifications of a low pass filter are:

$$\alpha \leq 1 \text{ dB for } f \leq 2 \text{ MHz}$$

$$\alpha \geq 60 \text{ dB for } f \geq 8 \text{ MHz}$$

Find the transformation of the Butterworth filter which satisfies these specifications. 5

**Group B**

5. (a) Draw the time response of a second order system for a unit step input and explain the time response specifications. Justify with sketches and definitions. 7

- (b) The open-loop transfer function of an unity feed control system is given by

$$G(s) = K/s(1 + Ts)$$

- (i) By what factor should the amplifier gain,  $K$ , be multiplied in order that the damping ratio is increased from 0.2 to 0.87? 7
- (ii) By what factor should  $K$  be multiplied (reduced) so that the system overshoot for unit step excitation is reduced from 60% to 20%? 6
6. (a) What are the necessary and sufficient conditions under which a system is said to be absolutely stable with a view to Routh-Hurwitz criterion? Justify in brief. 6
- (b) By applying Routh criterion, determine the values of  $K$  which will cause sustained oscillations in the unity feedback closed-loop system. What are the corresponding oscillation frequencies? 6

- (c) A feedback system has an open loop transfer functions of which

$$GH(s) = Ke^{-s} / s(s^2 + 5s + 9),$$

Determine, by use of Routh-Hurwitz criterion, the maximum value of  $K$  for the closed loop system to be stable. 8

7. (a) What are the procedures to be adopted to find the stability of a linear control system with the help of polar graph (Nyquist plot). Also, write the procedure to be adopted to find the gain margin and phase margin of the said polar graph. 12

- (b) Draw the polar graph of the following transfer function :

$$G(s) = \frac{100}{s(s+2)(s+8)}$$

and draw the gain margin which must be  $> 1$  and also show the stability. 8

8. (a) Explain, with a neat diagram, the principle of a synchro system and show how it can be used as (i) a position controller, and (ii) speed controller. 12
- (b) Show, using a simple diagram, how an a.c. servomotor can be used for position control. 8

**Group C**

9. Write short answer of any *five* of the following : 4×5
- (i) If two blocks of two-port networks, with parameter values  $(A_1, B_1, C_1, D_1)$  and  $(A_2, B_2, C_2, D_2)$  are cascaded in series, how can you obtain the  $(A, B, C, D)$  parameter of the combination?
- (ii) How can one obtain the gain margin and phase margin from Bode plot?
- (iii) How is the order of a Chebyshev filter determined from the specification?

- (iv) What is the basic principle of a gyro and how can it be used to measure acceleration ?**
- (v) What are the roles played by P, I and D segments of a PID controller ?**
- (vi) How can one obtain the initial and final values of response due to a step function of input for a given transfer function ?**

**S'10 : 4 AN : EC 404 (1480)**

**CIRCUIT THEORY AND CONTROL**

*Time : Three hours*

*Maximum Marks : 100*

*Answer FIVE questions, taking ANY TWO from Group A, ANY TWO from Group B and ALL from Group C.*

*All parts of a question ( a, b, etc. ) should be answered at one place.*

*Answer should be brief and to-the-point and be supplemented with neat sketches. Unnecessary long answers may result in loss of marks.*

*Any missing or wrong data may be assumed suitably giving proper justification.*

*Figures on the right-hand side margin indicate full marks .*

**Group A**

1. (a) Describe tree, loop current and node pair voltage in electrical circuits. 5
- (b) Use nodal voltage method and find the power dissipated in the 10 ohms resistor on the circuit shown in Fig.1. 10

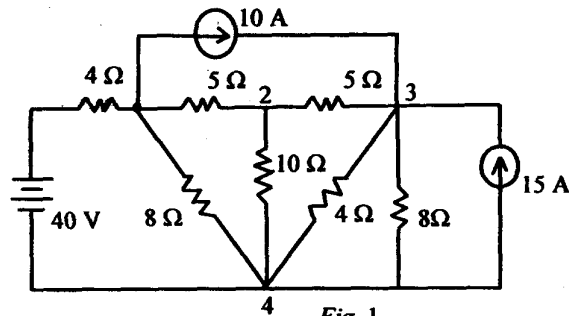

Fig. 1

(Turn Over)



(c) State and prove the convolution properties of Laplace transform. 5

2. (a) For the signal, shown in Fig. 2, find the Laplace transform. 7

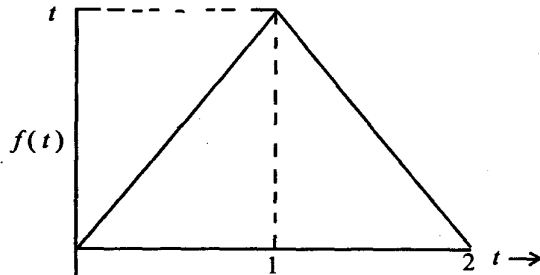

Fig. 2

(b) Find the inverse Laplace transform for  $F(s) = (7s + 2)/(s^3 + 3s^2 + 2s)$ . 5

(c) State and prove the time scaling properties of Fourier transform. 8

3. (a) A series R-L-C circuit, with  $R = 5\Omega$ ,  $L = 0.1H$  and  $C = 500 \times 10^{-6}F$ , has a d.c. voltage of 100V applied at  $t = 0$  through a switch. Find the resulting transient current. 8

(b) Explain the dot rule for coupled circuits. How do self and mutual inductance, affect the circuit analysis? 5

(c) Determine the Y-parameters of two port network shown in Fig. 3 7

S'10: 4AN: EC 404 (1480)

( 2 )

(Continued)

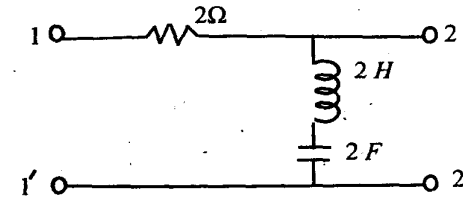

Fig. 3

4. (a) Define resonance. How does parallel resonance differ from series resonance? Where do they find applications? 5
- (b) What do you mean by a high Q circuits? What is the difficulty in design of such circuits? 5
- (c) Compare in detail the characteristics of Butterworth and Chebyshev filters. 5
- (d) A coil of resistance  $2\Omega$  and inductance  $0.01H$  is connected in series with a capacitor C. If maximum current occurs at 25Hz, find C. 5

**Group B**

5. (a) What are open-loop and closed-loop systems? Explain with examples. 5
- (b) Define the transfer function of a circuit. Find the transfer function for the circuit shown in Fig. 4. 5

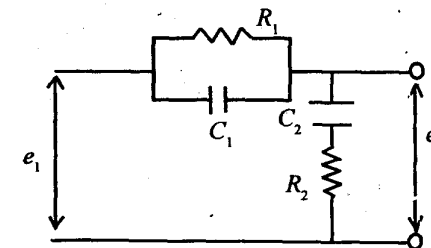

Fig. 4

S'10: 4AN: EC 404 (1480)

( 3 )

(Turn Over)

- (c) For the block diagram, shown in Fig.5, find  $C/R$  by block diagram reduction method. 10

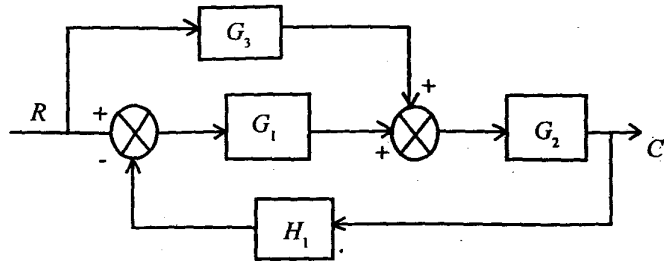

Fig. 5

6. (a) Explain the principles of position and speed control systems with the help of a neat diagram. 5
- (b) A unity feedback system has the forward path transfer function  $G(s) = 10/(s + 1)$ . Find the steady state error. 7
- (c) Determine the static error coefficients of the system shown in Fig.6. 8

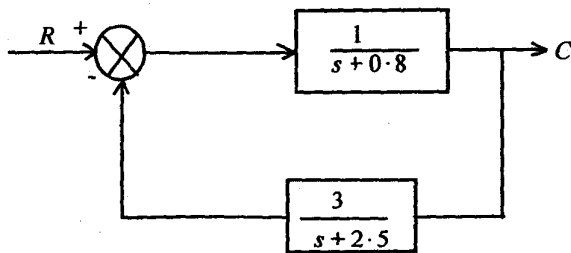

Fig. 6

7. (a) Explain Routh's stability criterion. 5

- (b) The open-loop transfer function of an unity feedback system is given by

$$G(s) = [k(s + 2)]/[s(s + 1)(s + 3)(s + 5)].$$

Determine the value of  $k$  for which the system is just stable. 8

- (c) Sketch the bode plots for the network shown in Fig. 7 and comment on its stability. 7

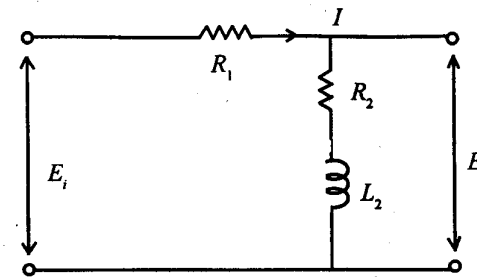

Fig. 7

8. Write technical notes on the following : 5 x 4
- (a) PI and PID controllers
- (b) Polar plots
- (c) Synchros
- (d) Maximum power theorem.

**Group C**

9. Write short answer on the following : 2 x 10
- (i) How will you express ABCD in terms of Y-parameters ?

S'10: 4AN: EC 404 (1480) ( 5 ) (Turn Over)

- (ii) Outline merits and demerits of closed-loop systems.
- (iii) What are the advantages of signal flow graphs ?
- (iv) What are the differences between power amplifier and pre-amplifier ?
- (v) What is complex frequency ?
- (vi) What is root locus plot of a stable system ?
- (vii) What information gain margin of Nyquist plot provides ?
- (viii) Does superposition theorem applies to non-linear networks.
- (ix) Capacitance provides a phase lag or phase lead. Comment.
- (x) Low-pass circuit can be designed with inductor and capacitor. Comment ?

**W'10:4AN:EC 404 (1480)****CIRCUIT THEORY AND CONTROL**

*Time : Three hours*

*Maximum Marks : 100*

*Answer FIVE questions, taking ANY TWO from Group A,  
ANY TWO from Group B and ALL from Group C.*

*All parts of a question (a, b, etc.) should  
be answered at one place.*

*Answer should be brief and to-the-point and be supplemented  
with neat sketches. Unnecessary long answers may  
result in loss of marks.*

*Any missing or wrong data may be assumed suitably giving  
proper justification.*

*Figures on the right-hand side margin indicate full marks.*

**Group A**

1. (a) Define the following terms related to a network :  
(i) Branch, (ii) node, (iii) tree, (iv) cut-set of a  
network graph, and (v) mesh. 5 × 2
- (b) Prove that the rank of a circuit matrix is  $(e - v + 1)$   
for a connected graph, where  $e$  and  $v$  represent  
number of edges and vertices, respectively. 8
- (c) Write the difference between a loop and a mesh. 2
2. (a) Write the differences between 'Fourier trans-  
form' and 'Fourier series'. How is the Fourier  
transform derived from Fourier series? 4

- (b) Obtain the Fourier transform of a rectangular pulse of duration '2 sec' and having a magnitude of 10 V. 6
- (c) State and prove convolution theorem and write its significance. 8 + 2
- 3. (a) Find the Y-parameters of the network shown in Fig. 1: 10

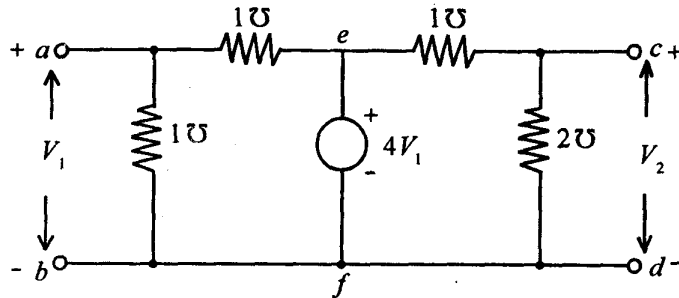

Fig. 1

- (b) Find out the ABCD parameters of the network shown in Fig. 2. Also, find the image parameters for the network. 10

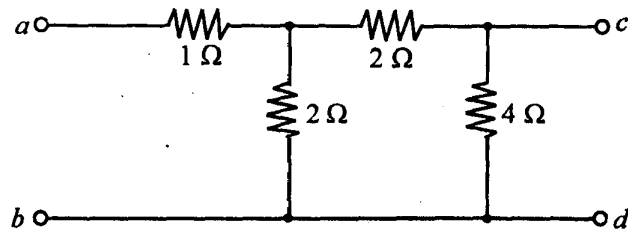

Fig. 2

- 4. (a) What do you mean by order of a filter? Design a second order Butterworth low pass filter, with a passband gain of 4 and cut-off frequency of 1 kHz. 2 + 8

- (b) A coil of resistance 10 ohms and inductance 500 mH is connected in series with a capacitor. At 50 Hz applied voltage, the current is found to be maximum. Another capacitor is connected in parallel with the series combination. What should be the value of the capacitance such that the combination is at resonance of 100 Hz? Calculate the total supply current in each case. 10

**Group B**

- 5. Make a comparison between the following: 5 + 5 + 10
  - (i) Open loop system and closed loop system
  - (ii) Integral control and derivative control
  - (iii) Position control and speed control system.
- 6. (a) Show that a linear discrete data system is stable if and if all roots of the characteristics equation lie inside the unit circle on the z-plane. 10
- (b) Describe the basic features of Routh Horowitz stability criterion. 6
- (c) What is state diagram? In what way it is different from signal flow graph? 2 + 2
- 7. (a) What do you mean by open loop transfer function of an unity feedback system. 4
- (b) Describe the following: (i) Nyquist polar plot; (ii) Bode plot for the system shown in Fig. 3: 5 + 5

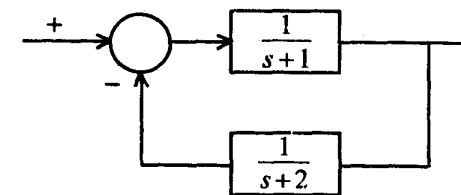

Fig. 3

- (c) What is rate-feedback control? What is the effect of the derivative feedback action on transient response? Describe the difference between transient response and steady state response for a system. 6
8. (a) With a neat schematic diagram, describe the operation of a d.c. servomechanism system with field control. Derive the transfer function of the system. 6 + 8
- (b) Write a short note on PID controller. 6

### Group C

9. Choose the *correct* answer for the following: 10 × 2
- (i) Laplace transform of a unit step function is
- (a) 1  
(b)  $s$   
(c)  $1/s^2$   
(d)  $1/s$
- (ii) The number of branches in a network is 'b', the number of nodes is 'n', and the number of dependent loop is 'l'. Then the number of independent current laws will be
- (a)  $n + l - 1$   
(b)  $b - l$   
(c)  $b - n$   
(d)  $n - 1$
- (iii) A two port network is symmetrical, if
- (a)  $z_{11} = z_{22}$

- (b)  $z_{12} = z_{21}$   
(c)  $AD - BC = 1$   
(d)  $h_{12} = -h_{21}$
- (iv) Function  $KS/[(s + 2)(s + 3)]$  has
- (a) 1 zero and 2 poles.  
(b) no zero and 2 poles.  
(c)  $K$  zeros and 2 poles.  
(d)  $K$  zeros and no poles.
- (v) In an impedance function, a pole at infinity is realized with the use of
- (a) a capacitance in series.  
(b) an inductance in series.  
(c) an inductance in parallel with the driving point terminals.  
(d) None of the above.
- (vi) Human system is
- (a) a complex control system.  
(b) a multivariable feedback control system.  
(c) a single variable feedback control system.  
(d) an open loop control system.
- (vii) In regenerative feedback, the transfer function of the system is given by
- (a)  $\frac{C(S)}{R(S)} = \frac{G(S)}{1 + H(S) \cdot G(S)}$   
(b)  $\frac{C(S)}{R(S)} = \frac{G(S) H(S)}{1 - G(S) H(S)}$

$$(c) \frac{C(S)}{R(S)} = \frac{G(S) H(S)}{1 + G(S) \cdot H(S)}$$

$$(d) \frac{C(S)}{R(S)} = \frac{G(S)}{1 - G(S) H(S)}$$

(viii) The transfer function of a signal flow graph, shown below, is given by

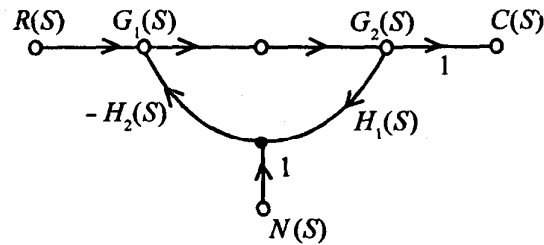

$$(a) \frac{-G_1(S) G_2(S) H_2(S)}{1 + G_1(S) G_2(S) H_1(S) H_2(S)}$$

$$(b) \frac{G_1(S) G_2(S)}{1 - G_1(S) G_2(S) H_1(S)}$$

$$(c) \frac{-[G_1(S) + G_2(S)] H_2(S)}{1 + [G_1(S) + G_2(S)] H_1(S) H_2(S)}$$

$$(d) \frac{G_1(S) G_2(S) H_1(S)}{1 - G_1(S) G_2(S) H_1(S) H_2(S)}$$

(ix) Damping in a control system is a function of

- (a) Gain
- (b)  $\sqrt{\text{Gain}}$
- (c)  $1/\sqrt{\text{Gain}}$
- (d)  $1/\text{Gain}$

(x) If a system has some poles lying on the imaginary axis, it is

- (a) absolutely stable.
- (b) unstable.
- (c) conditionally stable.
- (d) marginally stable.

**S'11:4 AN:EC 404 (1480)****CIRCUIT THEORY AND CONTROL**

*Time : Three hours*

*Maximum Marks : 100*

*Answer FIVE questions, taking ANY TWO from Group A,  
ANY TWO from Group B and ALL from Group C.*

*All parts of a question ( a, b, etc. ) should  
be answered at one place.*

*Answer should be brief and to-the-point and be supplemented  
with neat sketches. Unnecessary long answers may  
result in loss of marks.*

*Any missing or wrong data may be assumed suitably giving  
proper justification.*

*Figures on the right-hand side margin indicate full marks .*

**Group A**

1. (a) Write the node equations and determine the current through  $1\ \Omega$  resistor for the network shown in Fig. 1 : 10

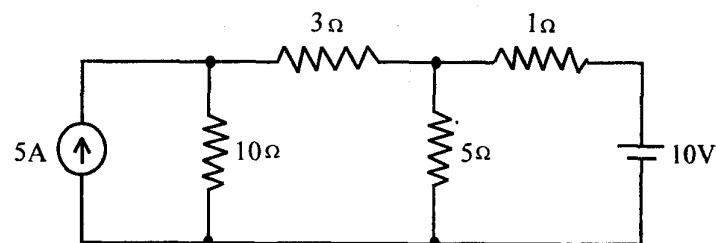

Fig. 1



(b) State and prove initial value theorem of Laplace transform. 5

(c) What are the restrictions of pole and zero locations in s-plane for transfer functions of a stable system? 5

2. (a) Draw the oriented graph of the network shown in Fig. 2 and write the cut-set matrix. 7

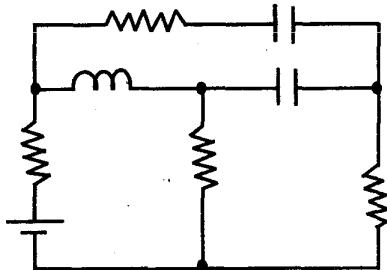

Fig. 2

(b) For a series R-L circuit shown in Fig. 3, a constant voltage of 10V is applied at  $t=0$ . Using Laplace transform, find  $i(t)$  and at what time does the voltage across the resistor and inductor equal? 10

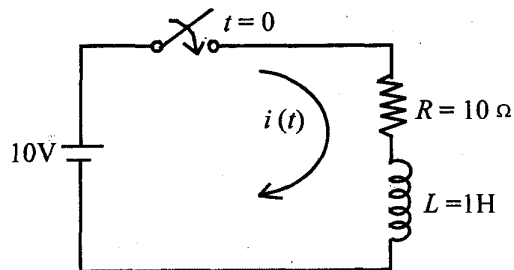

Fig. 3

(c) What is meant by maximally flat response of low-pass filter? 3

3. (a) Plot the half-wave rectified sine wave signal and determine the trigonometric Fourier series representation of it. 7

(b) For the network, shown in Fig. 4, find the driving point impedance,  $Z(s)$ , and plot pole-zero diagram. 7

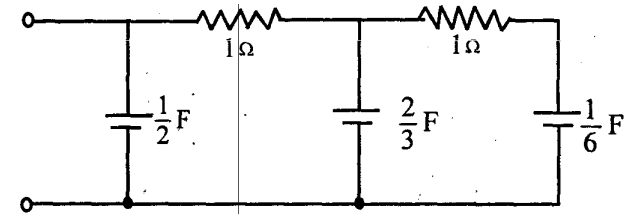

Fig. 4

(c) Find the value of resistance 'R' so that the circuit shown in Fig. 5 resonates at supply frequency. 6

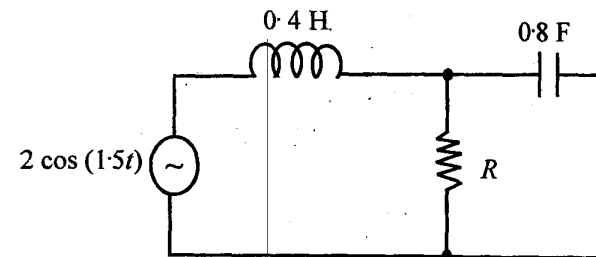

Fig. 5

4. (a) Find the impulse response for the transfer function  $X(s)$  given by 7

$$X(s) = \frac{2s + 4}{s^2 + 4s + 13}$$

(b) Convert a low-pass filter, shown in Fig. 6, into a high pass filter with cut-off frequency  $\omega_c = 10^6$  rad/sec and load resistance  $R_L = 500 \Omega$ .

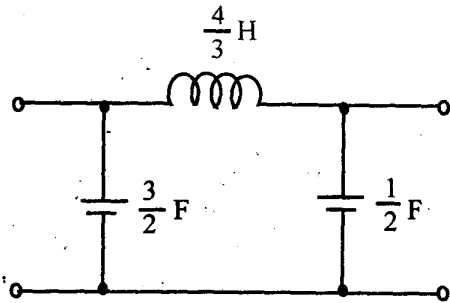

Fig. 6

(c) What is two-port network? Explain relation between its Z-parameters and Y-parameters.

**Group B**

- 5. (a) Explain the effect of negative feedback on stability against temperature variations. 6
- (b) Explain the construction and working principle of a.c. servomotor with a neat diagram. 8
- (c) Using Routh-Hurwitz criterion, verify the stability of the system having characteristic equation  $S^5 + S^4 + 2S^3 + 2S^2 + 3S + 5 = 0$ . 6
- 6. (a) Using a block diagram reduction technique, find closed loop transfer function of the system whose block diagram is shown in Fig. 7. 10

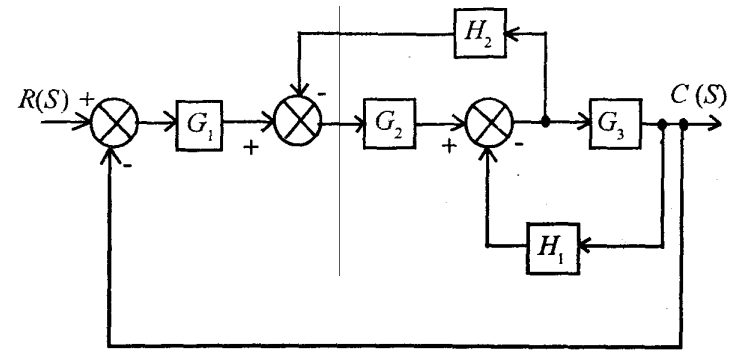

Fig. 7

(b) Obtain the unit step response of a unity feedback system whose open loop transfer function is given by 10

$$G(s) = \frac{4}{s(s+5)}$$

7. (a) Sketch the polar plot for 10

$$G(s) = \frac{20}{s(s+1)(s+2)}$$

(b) Write short notes on the following : 3 + 3 + 4

- (i) Potentiometer
- (ii) Synchros
- (iii) Gyros.

8. (a) A closed loop control system is shown in Fig. 8. Determine the value of K for which the steady

state error to a unity ramp will be 0.02. 10

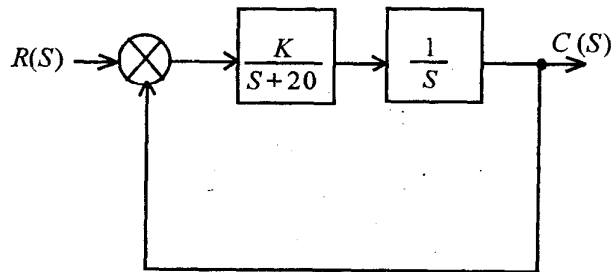

Fig. 8

- (b) Explain the effect of PD controller on the system performance. 6
- (c) For a system, what do you mean by gain margin and phase margin? 4

**Group C**

9. Answer the following in brief : 10 × 2

- (i) What is degree of N-node and spanning tree?
- (ii) Determine the final value of the current whose Laplace transform is given by
 
$$I(s) = \frac{0.42}{s(s^2 + 0.35s + 0.816)}$$
- (iii) If a coil of 150 turns is linked with a flux of 0.01 Wb when carrying current of 10A, calculate the inductance of the coil.
- (iv) What is the location of poles for stable systems?

- (v) State whether the Chebyshev filter has a sharper roll off than Butterworth filter.
- (vi) Write Mason's gain formula.
- (vii) For what purpose a tachogenerator is used?
- (viii) What is the type of damping in the system defined by transfer function
 
$$H(s) = \frac{10}{s^2 + 6s + 10}$$
- (ix) Which is greater between gain and phase cross-over frequency?
- (x) When a proportional controller is introduced in a system, its performance improves or not?

**W'11:4AN:EC404 (1480)****CIRCUIT THEORY AND CONTROL***Time : Three hours**Maximum Marks : 100*

*Answer FIVE questions, taking ANY TWO from Group A, ANY TWO from Group B and ALL from Group C.*

*All parts of a question (a, b, etc.) should be answered at one place.*

*Answer should be brief and to-the-point and be supplemented with neat sketches. Unnecessary long answers may result in loss of marks.*

*Any missing or wrong data may be assumed suitably giving proper justification.*

*Figures on the right-hand side margin indicate full marks.*

**Group A**

1. (a) Find the inverse transformation of the function 8

$$F(s) = \frac{s^2 + 6s + 8}{s^3 + 4s^2 + 3s}$$

- (b) State the initial and final value theorems. Compute the Laplace transform of the function

$$f(t) = (1 + 3e^{-2t} + 4te^{-2t})u(t).$$

Verify the initial value theorem for this function. 4 + 3 + 5

2. (a) Only one half-cycle (starting from  $t = 0$ ) is present for a sinusoidal wave of amplitude 2 V and time period 0.02 s. Find the time-domain equation and calculate the Laplace transform for this half-cycle. 5

- (b) Explain the difference between a planar and a non-planar graph with typical circuit diagrams. Write the co-relation between nodes, branches and links. What is the reason of getting this relation ? 4
- (c) For the given network (Fig. 1), neatly draw the graph and a tree. Show the link currents on the graph and construct a tie-set schedule for that tree. Explain, in detail, the construction of the tie-set. Define the term 'tie-set'. Write the equations for the branch currents in terms of the link current. Also, write the KVL equations from the tie-set. 11

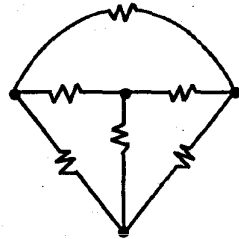

Fig. 1

3. (a) The expression below represents a driving point function of one-port network. Identify the violation of restriction in respect of the location of poles and zeros on the  $s$ -plane. 2

$$F(s) = \frac{s^3 + 5s^2 + 6s}{s^2 - 4s + 5}$$

- (b) A resistor  $R = 4 \Omega$ , in inductor  $L = 2 \text{ H}$  and a capacitor  $C = 1 \text{ F}$  are connected in series across a d.c. voltage source of 12 V. (i) Draw the function network and calculate the impedance function  $Z(s)$  and the series current function  $I(s)$ . Assume zero initial condition for the energy storing elements, (ii) If at  $t = 0$ , the current through the inductor is 2 A and the voltage across the capacitor is 5 V, determine the series current function. 5 + 6

- (c) The driving point impedance of a one-port reactive network is given by

$$Z(s) = 5 \frac{(s^2 + 4)(s^2 + 25)}{s(s^2 + 16)}$$

Obtain the first Foster network. 7

4. (a) Write the two-port  $z$ -parameter and ABCD parameter equations and define the parameters. From the  $z$ -parameter equations, derive the expressions for ABCD parameters in terms of  $z$ -parameters. 4 + 6

- (b) A fictitious transmission line is represented by a two-port circuit as shown in Fig. 2. Determine the ABCD constants of the line. If  $Z_1 = (4 + j60) \Omega$  and  $Z_2 = -j200 \Omega$ , compute the transmission line constants and also calculate the value of the expression AD-BC. 7 + 3

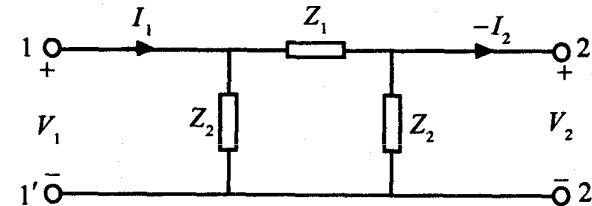

Fig. 2

**Group B**

5. (a) Explain the unit step response and unit ramp response of first order system. Plot the unit step response curve of a second order control system represented by a generalized second order differential equation. 5 + 3

(b) Determine the transfer function of the system represented by the block diagram shown in Fig. 3 : 5

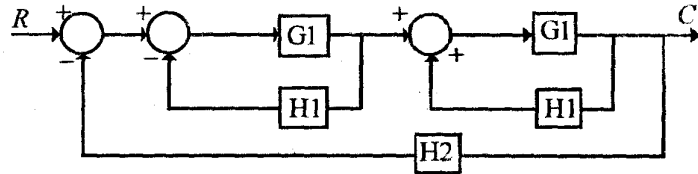

Fig. 3

- (c) Determine the gain and phase margins for a system with the open loop transfer function given by  $GH = 2/(s + 1)$ . 7
6. (a) Define the terms with an example : (i) source, (ii) path gain, and (iii) loop gain. 6
- (b) Draw the signal flow graph for the block diagram shown in Fig. 4. Determine the system transfer function by use of the Mason's gain formula : 9

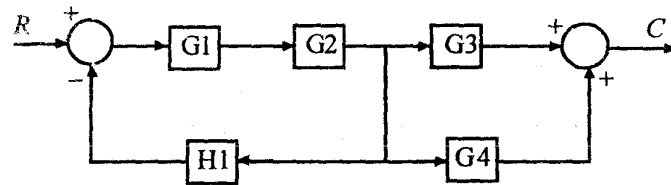

Fig. 4

- (c) Determine the system differential equation from the system transfer function 5
- $$H(s) = \frac{(s+1)(s+3)}{s(s+2)(s+4)}$$
7. (a) Explain the basic differences between polar graph criterion, Bode plot criterion, and Nyquist criterion in frequency domain. 7

(b) To find the absolute stability in a control time invariant linear system, which one is preferable either the Routh-Hurwitz criterion or Nyquist criterion. Write with necessary reasons. 4

(c) The characteristic equation of a given system is

$$s^3 + (K + 4)s^2 + 6s + 12 = 0$$

With the help of Routh stability criterion, determine the values of K for which the system would be stable. 9

8. (a) Design a PID controller, using operational amplifier, and express proportional gain, integral gain and derivative gain in terms of network elements. 10
- (b) Write short notes on: (i) Synchros, (ii) tachogenerators. 5 + 5

**Group C**

9. Choose the correct answer(s) for the following : 10 x 2
- (i) Which one of the following is a function of a filter ?
- (a) Noise blocker
  - (b) Signal booster
  - (c) Radio and TV channel demarcation
  - (d) All of the above.
- (ii) Which one of the following is not an even function ?
- (a) Constant K
  - (b) t
  - (c) t<sup>2</sup>
  - (d) cos(t)

- (iii) A function  $f(t) = Ate^{-at}$ . What are the types of poles of  $F(s)$  ?
- (a) Repeated complex
  - (b) Repeated real
  - (c) Distinct complex
  - (d) Distinct real.
- (iv) Which one of the following gives the correct number of basic loops ?
- (a) Equal to the number of branches
  - (b) Equal to the number of links
  - (c) Equal to the number of elements
  - (d) Equal to the number of nodes.
- (v) When a pure LC parallel circuit is in resonance, the circuit condition can be represented by
- (a) a short-circuit.
  - (b) an open circuit.
  - (c) normal parallel circuit.
  - (d) None of the above.
- (vi) A servo mechanism is a feedback control system required to control
- (a) position.
  - (b) derivative of position.
  - (c) integral of position.
  - (d) either (a) or (c) above.
  - (e) either (a) or (b) above.

- (vii) Choose a non-linear system:
- (a) Temperature controlled furnace
  - (b) Automatic voltage stabilizers
  - (c) Servometers working in saturated region
  - (d) All of the above.
- (viii) Poles are the complex frequencies of a transfer function, where the response becomes
- (a) infinite.
  - (b) zero.
  - (c) oscillatory.
  - (d) decaying.
- (ix) A transfer function is the Laplace transform of the output of a system whose input is
- (a) unity.
  - (b) impulse.
  - (c) zero.
  - (d) ramp.
  - (e) step.
- (x) To reduce steady state error,
- (a) decrease natural frequency.
  - (b) decrease damping.
  - (c) increase damped frequency.
  - (d) increase time constant.
  - (e) increase gain constant of the system.

**W'13: 4 AN: EC 404 (1480)****CIRCUIT THEORY AND CONTROL***Time : Three hours**Maximum Marks : 100*

*Answer FIVE questions, taking ANY TWO from Group A,  
ANY TWO from Group B and ALL from Group C.*

*All parts of a question ( a,b,etc.) should  
be answered at one place.*

*Answer should be brief and to-the-point and be supplemented  
with neat sketches. Unnecessary long answers may  
result in loss of marks.*

*Any missing or wrong data may be assumed suitably giving  
proper justification.*

*Figures on the right-hand side margin indicate full marks.*

**Group A**

1. (a) For the given network shown in Fig.1, calculate current through branch AB. 10

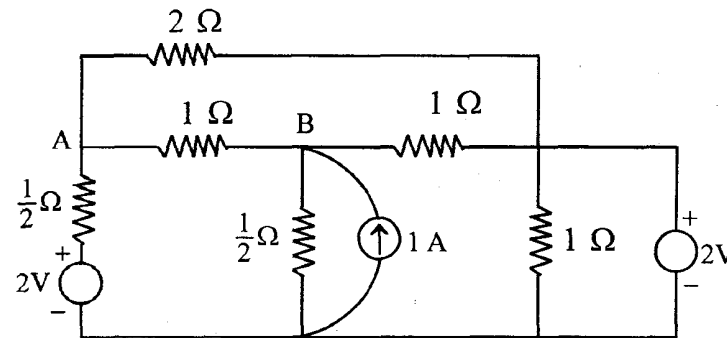

Fig. 1



- (b) For the network shown in Fig. 2, calculate node admittance matrix and nodal voltages. Use graphical analysis. 10

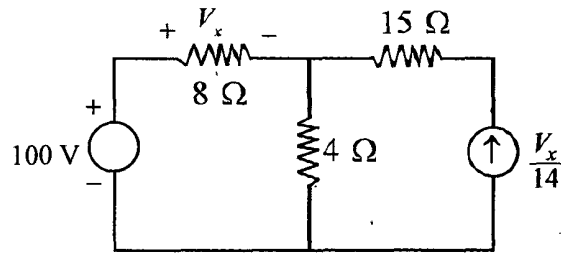

Fig. 2

2. (a) The circuit shown in Fig. 3 is initially under steady state condition with switch S closed. Switch S is opened at  $t = 0$ . Find the voltage across the inductance  $L$  as function of  $t$ . Use Laplace transform method. 10

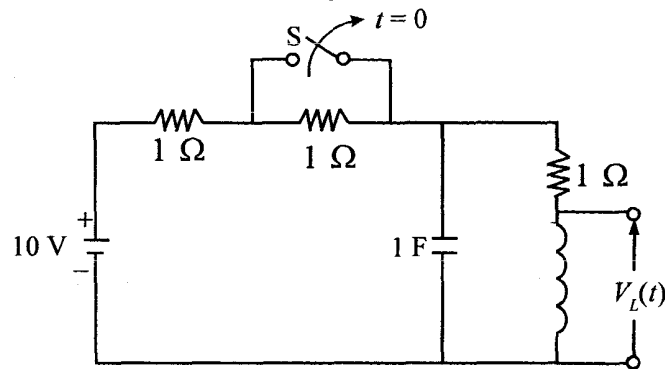

Fig. 3

- (b) Determine the function  $f(t)$ , if Fourier transform of the function is

$$F(j\omega) = Ae^{j\pi/2} \text{ for } -\omega_0 < \omega < 0$$

$$F(j\omega) = Ae^{-j\pi/2} \text{ for } 0 < \omega < \omega_0$$

Also, find the Laplace transform for shifted and singular functions. 10

3. (a) Calculate ABCD parameters of a two-port symmetrical network shown in Fig. 4. 10

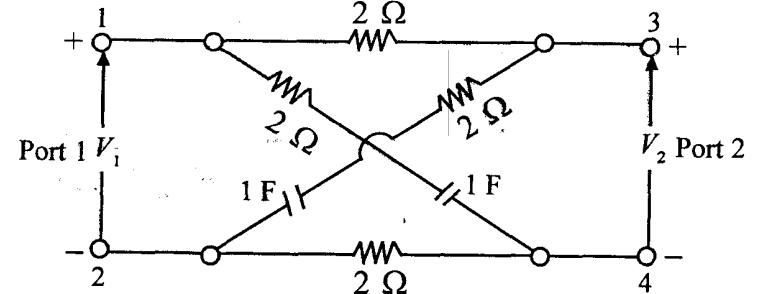

Fig. 4

- (b) What is parallel resonance? Derive its bandwidth. Also, calculate maximum impedance conditions with  $C, L,$  and  $f$  as variables. 10

4. (a) Explain band-pass constant K-type filter. Derive its characteristic impedance and resonant frequency. Plot characteristic impedance, attenuation and phase shift as a function of frequency. 10  
 (b) Design a second order Butterworth low pass filter having upper cut-off frequency of 1 kHz. 10

**Group B**

5. (a) Draw a signal flow graph and find the closed loop transfer function for the block diagram shown in Fig. 5. 10

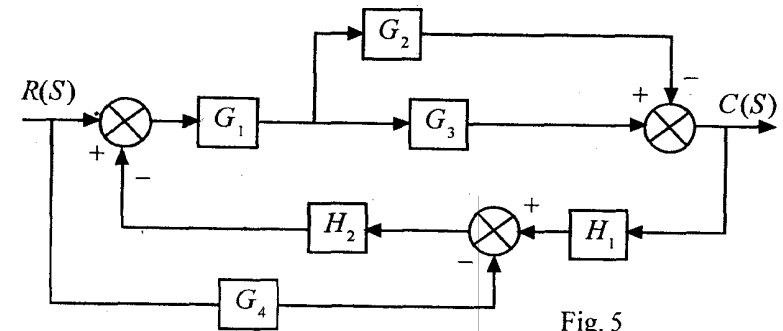

Fig. 5

- (b) A positional control system with velocity feedback is shown in Fig. 6. What is the response of the system for unit step input ? 10

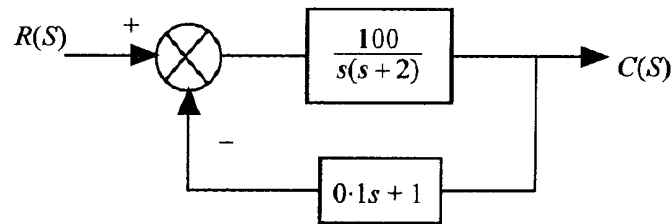

Fig. 6

6. (a) Derive the transfer function for the armature and field controlled d.c. motor. 10

- (b) For a system

$$G(s)H(s) = K/s^2(s+2)(s+3),$$

find the value of  $K$  to limit steady state error to 10 when input to system is  $1 + 10t + 40/2t^2$ . 10

7. (a) Sketch the polar plot for the following transfer function :

$$G(s) = 10(s+2)(s+4)/s(s^2-3s+10)$$

Find gain cross-over frequency, phase cross-over frequency, gain margin and phase margin. 10

- (b) A system has open loop transfer function as

$$G(s)H(s) = 10 / s(s+5),$$

find the undamped natural frequency, damping ratio, damped natural frequency, rise time, peak time, peak overshoot and the settling time with 2 % criterion. 10

8. (a) Construct Nyquist plot for a feedback control system whose open loop transfer function is given by

$$G(s)H(s) = 5/s(1-s)$$

Comment on the stability of open loop and closed loop transfer function. 10

- (b) Explain PID and PD controllers. 10

### Group C

9. Answer the following in brief : 10 × 2

- (i) What is a dominant pole ?
- (ii) What is frequency transformation ?
- (iii) List properties of cut-set matrix.
- (iv) List properties of transfer function.
- (v) State the condition for a Butterworth and Chebyshev to work as low pass or high pass filter.
- (vi) How to find the stability of the system by using polar plot ?
- (vii) What is direct root locus, inverse root locus and root contours ?
- (viii) Compare the block diagram representation and signal flow graph.
- (ix) What is the effect on system performance when a proportional controller is introduced in a system ?
- (x) Explain all the time domain specifications with a neat sketch.

You may [download prospectus](#) to buy excellent study material for AMIE exams.

You will also get **full access to our online support** with our course which includes latest AMIE question papers, model test papers, eBooks, audio and video lectures, course updates and interactive objective questions.

## **AMIE(I) Study Circle**

**Website:** [www.amiestudycircle.com](http://www.amiestudycircle.com)

**WhatsApp:** 9412903929

**Email:** [info@amiestudycircle.com](mailto:info@amiestudycircle.com)