

CBSE SCREENING MEDICAL ENTRANCE

SOLVED PAPER 2005

Physics

1. A coil in the shape of an equilateral triangle of side l is suspended between the pole pieces of a permanent magnet such that \vec{B} is in plane of the coil. If due to a current i in the triangle a torque τ acts on it, the side l of the triangle is :

(a) $\frac{2}{\sqrt{3}} \left(\frac{\tau}{Bi} \right)^{1/2}$ (b) $\frac{2}{\sqrt{3}} \left(\frac{\tau}{Bi} \right)$
 (c) $2 \left(\frac{\tau}{\sqrt{3} Bi} \right)^{1/2}$ (d) $\frac{1}{\sqrt{3}} \frac{\tau}{Bi}$

2. Two batteries, one of emf 18 V and internal resistance 2Ω and the other of emf 12 V and internal resistance 1Ω , are connected as shown. The voltmeter V will record a reading of :

(a) 15 V (b) 30 V
 (c) 14 V (d) 18 V

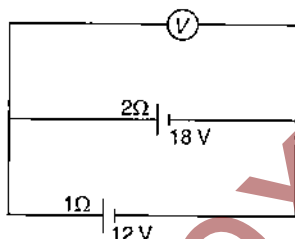

3. A point source emits sound equally in all directions in a non-absorbing medium. Two points P and Q are at distance of 2m and 3m respectively from the source. The ratio of the intensities of the waves at P and Q is :

(a) 9 : 4 (b) 2 : 3
 (c) 3 : 2 (d) 4 : 9

4. A bomb of mass 30 kg at rest explodes into two pieces of masses 18 kg and 12 kg. The velocity of 18 kg mass is 6 ms^{-1} . The kinetic energy of the other mass is :

(a) 256 J (b) 486 J
 (c) 524 J (d) 324 J

5. A drum of radius R and mass M , rolls down without slipping along an inclined plane of angle θ . The frictional force :

- (a) converts translational energy to rotational energy
 (b) dissipates energy as heat
 (c) decreases the rotational motion
 (d) decreases the rotational and translational motion

6. Imagine a new planet having the same density as that of earth but it is 3 times bigger than the earth in size. If the acceleration due to gravity on the surface of earth is g and that on the surface of the new planet is g' , then :

(a) $g' = 3g$ (b) $g' = \frac{g}{9}$
 (c) $g' = 9g$ (d) $g' = 27g$

7. A network of four capacitors of capacity equal to $C_1 = C$, $C_2 = 2C$, $C_3 = 3C$ and $C_4 = 4C$ are connected to a battery as shown in the figure. The ratio of the charges on C_2 and C_4 is :

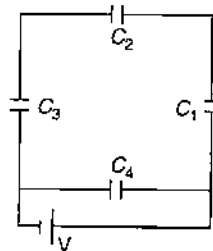

(a) $\frac{22}{3}$ (b) $\frac{3}{22}$
 (c) $\frac{7}{4}$ (d) $\frac{4}{7}$

8. Which of the following circular rods, (given radius r and length l) each made of the same material and whose ends are maintained at the same temperature will conduct most heat ?
- (a) $r = 2r_0; l = 2l_0$ (b) $r = 2r_0; l = l_0$
 (c) $r = r_0; l = l_0$ (d) $r = r_0; l = 2l_0$
9. In the reaction ${}^2_1\text{H} + {}^3_1\text{H} \rightarrow {}^4_2\text{He} + {}^1_0\text{n}$, if the binding energies of ${}^2_1\text{H}$, ${}^3_1\text{H}$ and ${}^4_2\text{He}$ are respectively a , b and c (in MeV), then the energy (in MeV) released in this reaction is :
- (a) $c + a - b$ (b) $c - a - b$
 (c) $a + b + c$ (d) $a + b - c$
10. A very long straight wire carries a current I . At the instant when a charge $+Q$ at point P has velocity \vec{v} , as shown, the force on the charge is :

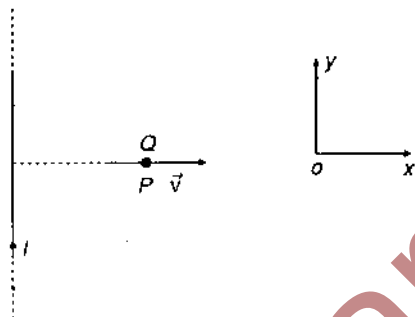

- (a) opposite to ox (b) along ox
 (c) opposite to oy (d) along oy
11. Energy levels A , B and C of a certain atom correspond to increasing values of energy i.e., $E_A < E_B < E_C$. If λ_1 , λ_2 and λ_3 are wavelengths of radiations corresponding to transitions C to B , B to A and C to A respectively, which of the following relations is correct ?
- (a) $\lambda_3 = \lambda_1 + \lambda_2$ (b) $\lambda_3 = \frac{\lambda_1 \lambda_2}{\lambda_1 + \lambda_2}$
 (c) $\lambda_1 + \lambda_2 + \lambda_3 = 0$ (d) $\lambda_3^2 = \lambda_1^2 + \lambda_2^2$
12. The work functions for metals A , B and C are respectively 1.92 eV, 2.0 eV and 5 eV. According to Einstein's equation, the metals which will emit photoelectrons for a radiation of wavelength 4100 Å is/are :
- (a) none (b) A only
 (c) A and B only (d) all the three metals
13. The nuclei of which one of the following pairs of nuclei are isotones ?

- (a) ${}_{34}\text{Se}^{74}$, ${}_{31}\text{Ga}^{71}$ (b) ${}_{42}\text{Mo}^{92}$, ${}_{40}\text{Zr}^{92}$
 (c) ${}_{38}\text{Sr}^{84}$, ${}_{38}\text{Sr}^{86}$ (d) ${}_{20}\text{Ca}^{40}$, ${}_{16}\text{S}^{32}$

14. As per this diagram a point charge $+q$ is placed at the origin O . Work done in taking another point charge $-Q$ from the point A [co-ordinates $(0, a)$] to another point B [co-ordinates $(a, 0)$] along the straight path AB is :

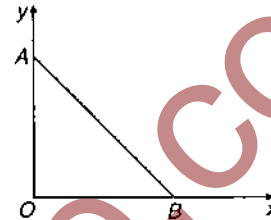

- (a) zero (b) $\left(\frac{-qQ}{4\pi\epsilon_0 a^2}\right) \sqrt{2}a$
 (c) $\left(\frac{qQ}{4\pi\epsilon_0 a^2}\right) \cdot \frac{a}{\sqrt{2}}$ (d) $\left(\frac{qQ}{4\pi\epsilon_0 a^2}\right) \sqrt{2}a$

15. As a result of change in the magnetic flux linked to the closed loop shown in the figure, an emf V volt is induced in the loop. The work done (joules) in taking a charge Q coulomb once along the loop is :

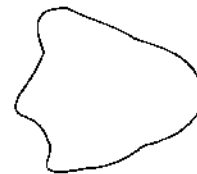

- (a) QV (b) zero (c) $2QV$ (d) $\frac{QV}{2}$

16. For the network shown in the figure, the value of the current i is :

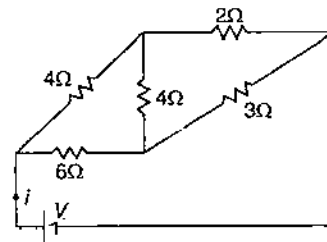

- (a) $\frac{9V}{35}$ (b) $\frac{5V}{18}$ (c) $\frac{5V}{9}$ (d) $\frac{18V}{5}$

17. The circular motion of a particle with constant speed is :
- simple harmonic but not periodic
 - periodic and simple harmonic
 - neither periodic nor simple harmonic
 - periodic but not simple harmonic
18. A particle executing simple harmonic motion of amplitude 5 cm has maximum speed of 31.4 cm/s. The frequency of its oscillation is :
- 3 Hz
 - 2 Hz
 - 4 Hz
 - 1 Hz
19. The ratio of the dimensions of Planck's constant and that of the moment of inertia is the dimension of :
- frequency
 - velocity
 - angular momentum
 - time
20. Which of the following processes is reversible ?
- Transfer of heat by radiation
 - Electrical heating of a nichrome wire
 - Transfer of heat by conduction
 - Isothermal compression
21. The temperature of inversion of a thermocouple is 620°C and the neutral temperature is 300°C . What is the temperature of cold junction ?
- 20°C
 - 320°C
 - -20°C
 - 40°C
22. A photosensitive metallic surface has work function, $h\nu_0$. If photons of energy $2h\nu_0$ fall on this surface, the electrons come out with a maximum velocity of 4×10^6 m/s. When the photon energy is increased to $5h\nu_0$, then maximum velocity of photoelectrons will be :
- 2×10^6 m/s
 - 2×10^7 m/s
 - 8×10^5 m/s
 - 8×10^6 m/s
23. Fission of nuclei is possible because the binding energy per nucleon in them :
- increases with mass number at high mass numbers
 - decreases with mass number at high mass numbers
 - increases with mass number at low mass numbers
 - decreases with mass number at low mass numbers
24. Application of a forward bias to a p-n junction:
- increases the number of donors on the n-side

- increases the electric field in the depletion zone
- increases the potential difference across the depletion zone
- widens the depletion zone

25. The displacement x of a particle varies with time t as $x = ae^{-\alpha t} + be^{\beta t}$, where a, b, α and β are positive constants. The velocity of the particle will :
- go on decreasing with time
 - be independent of α and β
 - drop to zero when $\alpha = \beta$
 - go on increasing with time
26. Two charges q_1 and q_2 are placed 30 cm apart, as shown in the figure. A third charge q_3 is moved along the arc of a circle of radius 40 cm from C to D . The change in the potential energy of the system is $\frac{q_3}{4\pi\epsilon_0} k$, where k is :

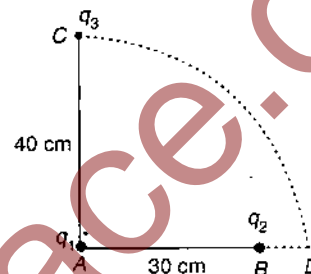

- $8q_2$
 - $8q_1$
 - $6q_2$
 - $6q_1$
27. In any fission process the ratio $\frac{\text{mass of fission products}}{\text{mass of parent nucleus}}$ is :
- less than 1
 - greater than 1
 - equal to 1
 - depends on the mass of parent nucleus
28. An ideal gas heat engine operates in Carnot cycle between 227°C and 127°C . It absorbs 6×10^4 cal of heat at higher temperature. Amount of heat converted to work is :
- 2.4×10^4 cal
 - 6×10^4 cal
 - 1.2×10^4 cal
 - 4.8×10^4 cal
29. If a vector $2\hat{i} + 3\hat{j} + 8\hat{k}$ is perpendicular to the vector $4\hat{j} - 4\hat{i} + \alpha\hat{k}$, then the value of α is :
- 1
 - $\frac{1}{2}$
 - $-\frac{1}{2}$
 - 1

30. Zener diode is used for :
- producing oscillations in an oscillator
 - amplification
 - stabilisation
 - rectification
31. A force F acting on an object varies with distance x as shown here. The force is in N and x is in m. The work done by the force in moving the object from $x = 0$ to $x = 6$ m is :

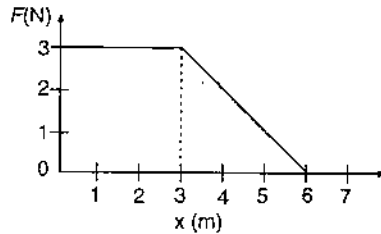

- 4.5 J
 - 13.5 J
 - 9.0 J
 - 18.0 J
32. A stone tied to the end of a string of 1 m long is whirled in a horizontal circle with a constant speed. If the stone makes 22 revolutions in 44 s, what is the magnitude and direction of acceleration of the stone ?
- $\frac{\pi^2}{4} \text{ ms}^{-2}$ and direction along the radius towards the centre
 - $\pi^2 \text{ ms}^{-2}$ and direction along the radius away from centre
 - $\pi^2 \text{ ms}^{-2}$ and direction along the radius towards the centre
 - $\pi^2 \text{ ms}^{-2}$ and direction along the tangent to the circle
33. If the magnetic dipole moment of an atom of diamagnetic material, paramagnetic material and ferromagnetic material are denoted by μ_d , μ_p and μ_f respectively, then :
- $\mu_d \neq 0$ and $\mu_f \neq 0$
 - $\mu_p = 0$ and $\mu_f \neq 0$
 - $\mu_d = 0$ and $\mu_p \neq 0$
 - $\mu_d \neq 0$ and $\mu_p = 0$
34. In a circuit, L , C and R are connected in series with an alternating voltage source of frequency f . The current leads the voltage by 45° . The value of C is :
- $\frac{1}{2\pi f(2\pi fL + R)}$
 - $\frac{1}{\pi f(2\pi fL + R)}$
 - $\frac{1}{2\pi f(2\pi fL - R)}$
 - $\frac{1}{\pi f(2\pi fL - R)}$

35. The angular resolution of a 10 cm diameter telescope at a wavelength of 5000 \AA is of order of :
- 10^6 rad
 - 10^{-2} rad
 - 10^{-4} rad
 - 10^{-6} rad
36. Two vibrating tuning forks produce progressive waves given by $y_1 = 4 \sin 500\pi t$ and $y_2 = 2 \sin 506\pi t$. Number of beats produced per minute is :
- 360
 - 180
 - 3
 - 60
37. When a wire of uniform cross-section a , length l and resistance R is bent into a complete circle, the resistance between two diametrically opposite points will be :
- $\frac{R}{4}$
 - $\frac{R}{8}$
 - $4R$
 - $\frac{R}{2}$
38. Carbon, silicon and germanium atoms have four valence electrons each. Their valence conduction bands are separated by energy band gaps represented by $(E_g)_C$, $(E_g)_{Si}$, $(E_g)_{Ge}$ respectively. Which one of the following relationships is true in their case
- $(E_g)_C > (E_g)_{Si}$
 - $(E_g)_C = (E_g)_{Si}$
 - $(E_g)_C < (E_g)_{Ge}$
 - $(E_g)_C < (E_g)_{Si}$
39. If λ_v , λ_x and λ_m represent the wavelength of visible light, X-rays and microwaves respectively, then :
- $\lambda_m > \lambda_x > \lambda_v$
 - $\lambda_v > \lambda_m > \lambda_x$
 - $\lambda_m > \lambda_v > \lambda_x$
 - $\lambda_v > \lambda_x > \lambda_m$
40. Two boys are standing at the ends A and B of a ground, where $AB = a$. The boy at B starts running in a direction perpendicular to AB with velocity v_1 . The boy at A starts running simultaneously with velocity v and catches the other boy in a time t , where t is :
- $\frac{a}{\sqrt{v^2 + v_1^2}}$
 - $\frac{a^2}{\sqrt{v^2 - v_1^2}}$
 - $\frac{a}{(v - v_1)}$
 - $\frac{a}{(v + v_1)}$
41. A 5-A fuse wire can withstand a maximum power of 1 W in circuit. The resistance of the fuse wire is :
- 0.2 Ω
 - 5 Ω
 - 0.4 Ω
 - 0.04 Ω

2. Two bodies have their moments of inertia I and $2I$ respectively about their axis of rotation. If their kinetic energies of rotation are equal, their angular momenta will be in the ratio :
- (a) 1 : 2 (b) $\sqrt{2} : 1$
(c) 2 : 1 (d) $1 : \sqrt{2}$
3. An electron moves in a circular orbit with a uniform speed v . It produces a magnetic field B at the centre of the circle. The radius of the circle is proportional to :
- (a) $\frac{B}{v}$ (b) $\frac{v}{B}$
(c) $\sqrt{\frac{v}{B}}$ (d) $\sqrt{\frac{B}{v}}$
4. Choose the only false statement from the following :
- (a) Substances with energy gap of the order of 10 eV are insulators
(b) The conductivity of a semiconductor increases with increases in temperature
(c) In conductors the valence and conduction bands may overlap
(d) The resistivity of a semiconductor increases with increase in temperature
5. If the angle between the vectors \vec{A} and \vec{B} is θ , the value of the product $(\vec{B} \times \vec{A}) \cdot \vec{A}$ is equal to :
- (a) $BA^2 \cos \theta$
(b) $BA^2 \sin \theta$
(c) $BA^2 \sin \theta \cos \theta$
(d) zero
46. The moment of inertia of a uniform circular disc of radius R and mass M about an axis passing from the edge of the disc and normal to the disc is :
- (a) $\frac{1}{2} MR^2$ (b) MR^2
(c) $\frac{7}{2} MR^2$ (d) $\frac{3}{2} MR^2$
47. Copper has face-centered cubic (fcc) lattice with interatomic spacing equal to 2.54 Å. The value of lattice constant for this lattice is :
- (a) 1.27 Å (b) 5.08 Å
(c) 2.54 Å (d) 3.59 Å
48. The total energy of an electron in the first excited state of hydrogen is about -3.4 eV. Its kinetic energy in this state is :
- (a) -3.4 eV (b) -6.8 eV
(c) 6.8 eV (d) 3.4 eV
49. For a satellite moving in an orbit around the earth, the ratio of kinetic energy to potential energy is :
- (a) 2 (b) $\frac{1}{2}$
(c) $\frac{1}{\sqrt{2}}$ (d) $\sqrt{2}$
50. A ball is thrown vertically upward. It has a speed of 10 m/s when it has reached one half of its maximum height. How high does the ball rise? (Taking $g = 10 \text{ m/s}^2$)
- (a) 15 m (b) 10 m
(c) 20 m (d) 5 m

Chemistry

1. Which amongst the following is the most stable carbocation?
- (a) $\text{CH}_3-\overset{+}{\text{C}}-\text{H}$ (b) $\text{CH}_3-\overset{+}{\text{C}}(\text{CH}_3)_2$
(c) $\overset{+}{\text{C}}\text{H}_3$ (d) $\text{CH}_3\overset{+}{\text{C}}\text{H}_2$
2. Products of the following reaction :
- $$\text{CH}_3\text{C} \equiv \text{C} \cdot \text{CH}_2\text{CH}_3 \xrightarrow{(1) \text{O}_3} \dots \xrightarrow{(2) \text{Hydrolysis}} \dots$$
- (a) $\text{CH}_3\text{CHO} + \text{CH}_3\text{CH}_2\text{CHO}$ (b) $\text{CH}_3\text{COOH} + \text{CH}_3\text{COCH}_3$
(c) $\text{CH}_3\text{COOH} + \text{HOOC} \cdot \text{CH}_2\text{CH}_3$ (d) $\text{CH}_3\text{COOH} + \text{CO}_2$
53. At 25°C, the dissociation constant of a base, BOH, is 1.0×10^{-12} . The concentration of hydroxyl ions in 0.01 M aqueous solution of the base would be :
- (a) $2.0 \times 10^{-6} \text{ mol L}^{-1}$
(b) $1.0 \times 10^{-5} \text{ mol L}^{-1}$
(c) $1.0 \times 10^{-6} \text{ mol L}^{-1}$
(d) $1.0 \times 10^{-7} \text{ mol L}^{-1}$

54. Which one of the following pairs represents stereoisomerism ?

- (a) Chain isomerism and rotational isomerism
 (b) Structural isomerism and geometric isomerism
 (c) Linkage isomerism and geometric isomerism
 (d) Optical isomerism and geometric isomerism

55. Aniline in a set of reactions yielded a product D.

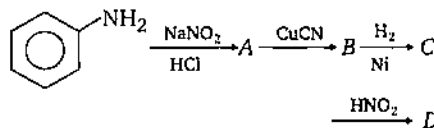

The structure of the product D would be :

- (a) $\text{C}_6\text{H}_5\text{CH}_2\text{NH}_2$
 (b) $\text{C}_6\text{H}_5\text{NHCH}_2\text{CH}_3$
 (c) $\text{C}_6\text{H}_5\text{NHOH}$
 (d) $\text{C}_6\text{H}_5\text{CH}_2\text{OH}$

56. The correct order in which the O — O bond length increases in the following is :

- (a) $\text{H}_2\text{O}_2 < \text{O}_2 < \text{O}_3$
 (b) $\text{O}_3 < \text{H}_2\text{O}_2 < \text{O}_2$
 (c) $\text{O}_2 < \text{O}_3 < \text{H}_2\text{O}_2$
 (d) $\text{O}_2 < \text{H}_2\text{O}_2 < \text{O}_3$

57. The mass of carbon anode consumed (giving only carbon dioxide) in the production of 270 kg of aluminium metal from bauxite by the Hall process is :

- (Atomic mass Al = 27)
 (a) 180 kg (b) 270 kg
 (c) 540 kg (d) 90 kg

58. In a set of reactions, acetic acid yielded a product D.

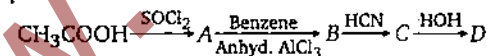

The structure of D would be :

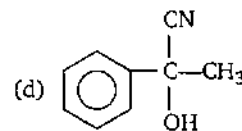
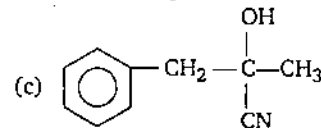
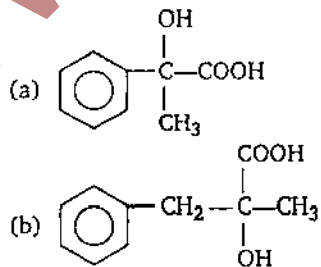

59. The cell membranes are mainly composed of

- (a) carbohydrates (b) proteins
 (c) phospholipids (d) fats

60. The major organic product formed from the following reaction :

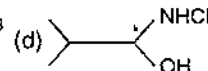
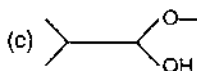
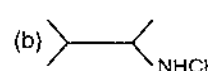
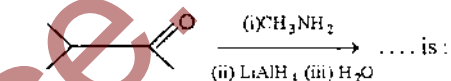

61. The number of moles of KMnO_4 reduced one mole of KI in alkaline medium is :

- (a) one fifth (b) five
 (c) one (d) two

62. Which of the following molecules has trigonal planar geometry ?

- (a) IF_3 (b) PCl_3
 (c) NH_3 (d) BF_3

63. The aqueous solution containing which one of the following ions will be colourless ?

- (Atomic no. : Sc = 21, Fe = 26, Ti = 22, Mn = 25)
 (a) Sc^{3+} (b) Fe^{2+}
 (c) Ti^{3+} (d) Mn^{2+}

64. Four successive members of the first row transition elements are listed below with their atomic numbers. Which one of them is expected to have the highest third ionization enthalpy ?

- (a) Vanadium (Z = 23)
 (b) Chromium (Z = 24)
 (c) Iron (Z = 26)
 (d) Manganese (Z = 25)

65. Which one of the following compounds is most acidic ?

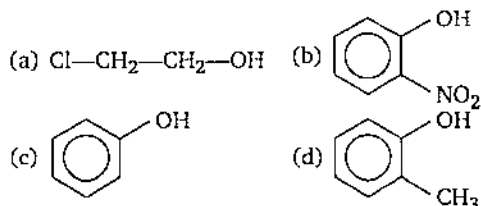

66. A reaction occurs spontaneously if :

- (a) $T\Delta S < \Delta H$ and both ΔH and ΔS are +ve
 (b) $T\Delta S > \Delta H$ and both ΔH and ΔS are +ve
 (c) $T\Delta S = \Delta H$ and both ΔH and ΔS are +ve
 (d) $T\Delta S > \Delta H$ and ΔH is +ve and ΔS is -ve

67. The monomer of the polymer :

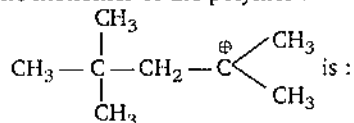

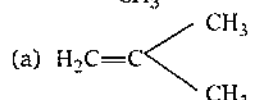
- (a) 
 (b) $(\text{CH}_3)_2\text{C}=\text{C}(\text{CH}_3)_2$
 (c) $\text{CH}_3\text{CH}=\text{CH}\cdot\text{CH}_3$
 (d) $\text{CH}_3\text{CH}=\text{CH}_2$

68. The correct sequence of increasing covalent character is represented by :

- (a) $\text{LiCl} < \text{NaCl} < \text{BeCl}_2$
 (b) $\text{BeCl}_2 < \text{NaCl} < \text{LiCl}$
 (c) $\text{NaCl} < \text{LiCl} < \text{BeCl}_2$
 (d) $\text{BeCl}_2 < \text{LiCl} < \text{NaCl}$

69. What is the correct relationship between the pHs of isomolar solutions of sodium oxide (pH_1), sodium sulphide (pH_2), sodium selenide (pH_3) and sodium telluride (pH_4) ?

- (a) $\text{pH}_1 > \text{pH}_2 \approx \text{pH}_3 > \text{pH}_4$
 (b) $\text{pH}_1 < \text{pH}_2 < \text{pH}_3 < \text{pH}_4$
 (c) $\text{pH}_1 < \text{pH}_2 < \text{pH}_3 \approx \text{pH}_4$
 (d) $\text{pH}_1 > \text{pH}_2 > \text{pH}_3 > \text{pH}_4$

70. Which of the following pairs of a chemical reaction is certain to result in a spontaneous reaction ?

- (a) Exothermic and decreasing disorder
 (b) Endothermic and increasing disorder
 (c) Exothermic and increasing disorder
 (d) Endothermic and decreasing disorder

71. The vapour pressure of two liquids P and Q are 80 and 60 torr, respectively. The total vapour

pressure of solution obtained by mixing 3 moles of P and 2 moles of Q would be :

- (a) 140 torr (b) 20 torr
 (c) 68 torr (d) 72 torr

72. Which one of the following alkenes will react faster with H_2 under catalytic hydrogenation conditions ?

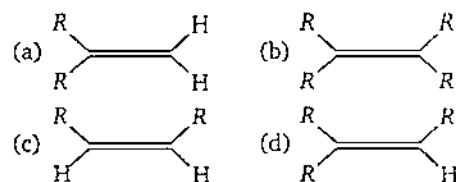

(R = Alkyl substituent)

73. For a first order reaction $A \longrightarrow B$, the reaction rate at reactant concentration of 0.01 M is found to be $2.0 \times 10^{-5} \text{ mol L}^{-1} \text{ s}^{-1}$. The half life period of the reaction is :

- (a) 220 s (b) 30 s (c) 300 s (d) 347 s

74. Which of the following is the electron deficient molecule ?

- (a) B_2H_6 (b) C_2H_6
 (c) PH_3 (d) SiH_4

75. A nuclide of an alkaline earth metal undergoes radioactive decay by emission of three α -particles in succession. The group of the periodic table to which the resulting daughter element would belong is :

- (a) Group 14 (b) Group 16
 (c) Group 4 (d) Group 6

76. The surface tension of which of the following liquid is maximum ?

- (a) H_2O (b) C_6H_6
 (c) CH_3OH (d) $\text{C}_2\text{H}_5\text{OH}$

77. The absolute enthalpy of neutralisation of the reaction :

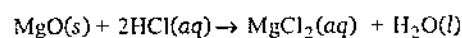

will be :

- (a) less than $-57.33 \text{ kJ mol}^{-1}$
 (b) $-57.33 \text{ kJ mol}^{-1}$
 (c) greater than $-57.33 \text{ kJ mol}^{-1}$
 (d) $57.33 \text{ kJ mol}^{-1}$

78. Which one of the following forms micelles in aqueous solution above certain concentration ?

- (a) Urea
 (b) Dodecyl trimethyl ammonium chloride
 (c) Pyridinium chloride
 (d) Glucose

79. Electrolytic reduction of nitrobenzene in weakly acidic medium gives :

- (a) aniline
- (b) nitrosobenzene
- (c) N-phenylhydroxylamine
- (d) p-hydroxyaniline

80. Equilibrium constants K_1 and K_2 for the following equilibria :

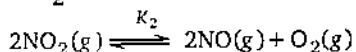
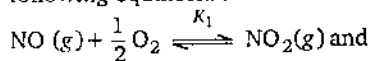

are related as :

- (a) $K_2 = \frac{1}{K_1}$
- (b) $K_2 = K_1^2$
- (c) $K_2 = \frac{K_1}{2}$
- (d) $K_2 = \frac{1}{K_1^2}$

81. Which of the following would have a permanent dipole moment ?

- (a) BF_3
- (b) SiF_4
- (c) SF_4
- (d) XeF_4

82. Which of the following undergoes nucleophilic substitution exclusively by $\text{S}_{\text{N}}1$ mechanism ?

- (a) Benzyl chloride
- (b) Ethyl chloride
- (c) Chlorobenzene
- (d) Isopropyl chloride

83. The rate of reaction between two reactants A and B decreases by a factor of 4, if the concentration of reactant B is doubled. The order of this reaction with respect to reactant B is :

- (a) -1
- (b) -2
- (c) 1
- (d) 2

84. In a face-centered cubic lattice, a unit cell is shared equally by how many unit cells ?

- (a) 8
- (b) 4
- (c) 2
- (d) 6

85. A solution of urea (mol. mass 56 g mol^{-1}) boils at 100.18°C at the atmospheric pressure. If k_f and k_b for water are 1.86 and $0.512 \text{ K kg mol}^{-1}$

respectively, the above solution will freeze at :

- (a) -6.54°C
- (b) 6.54°C
- (c) 0.654°C
- (d) -0.654°C

86. Which functional group participates in disulphide bond formation in proteins ?

- (a) Thiolactone
- (b) Thiol
- (c) Thioether
- (d) Thioester

87. Which one of the following is an inner orbital complex as well as diamagnetic in behaviour ?

(Atomic no. : Zn = 30, Cr = 24, Co = 27, Ni = 28)

- (a) $[\text{Zn}(\text{NH}_3)_6]^{2+}$
- (b) $[\text{Cr}(\text{NH}_3)_6]^{3+}$
- (c) $[\text{Co}(\text{NH}_3)_6]^{3+}$
- (d) $[\text{Ni}(\text{NH}_3)_6]^{2+}$

88. The chirality of the compound

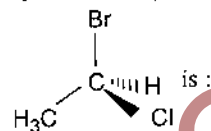

- (a) R
- (b) S
- (c) Z
- (d) E

89. H_2S gas when passed through a solution of cations containing HCl precipitates the cations of second group of qualitative analysis but not those belonging to the fourth group. It is because :

- (a) presence of HCl decreases the sulphide ion concentration
- (b) presence of HCl increases the sulphide ion concentration
- (c) solubility product of group II sulphides is more than that of group IV sulphides
- (d) sulphides of group IV cations are unstable in HCl

90. Which one of the following oxides is expected to exhibit paramagnetic behaviour ?

- (a) CO_2
- (b) SO_2
- (c) ClO_2
- (d) SiO_2

91. Which one of the following is expected to exhibit optical isomerism ?

- (en = ethylenediamine)
- (a) $\text{cis}[\text{Pt}(\text{NH}_3)_2\text{Cl}_2]$
- (b) $\text{trans}[\text{Co}(\text{en})_2\text{Cl}_2]$
- (c) $\text{trans}[\text{Pt}(\text{NH}_3)_2\text{Cl}_2]$
- (d) $\text{cis}[\text{Co}(\text{en})_2\text{Cl}_2]$

92. The energy of second Bohr orbit of the hydrogen atom is -328 kJ mol^{-1} ; hence the energy of fourth Bohr orbit would be :

- (a) -41 kJ mol^{-1}
- (b) $-1312 \text{ kJ mol}^{-1}$
- (c) -164 kJ mol^{-1}
- (d) -82 kJ mol^{-1}

93. The correct order of acid strength is :

- (a) $\text{HClO} < \text{HClO}_2 < \text{HClO}_3 < \text{HClO}_4$
- (b) $\text{HClO}_4 < \text{HClO} < \text{HClO}_2 < \text{HClO}_3$
- (c) $\text{HClO}_2 < \text{HClO}_3 < \text{HClO}_4 < \text{HClO}$
- (d) $\text{HClO}_4 < \text{HClO}_3 < \text{HClO}_2 < \text{HClO}$

94. The main reason for larger number of oxidation states exhibited by the actinides than the corresponding lanthanides, is :
- lesser energy difference between 5f and 6d orbitals than between 4f and 5d orbitals
 - larger atomic size of actinides than the lanthanides
 - more energy difference between 5f and 6d orbitals than between 4f and 5d orbitals
 - greater reactive nature of the actinides than the lanthanides

95. Names of some compounds are given. Which one is not correct in IUPAC system ?

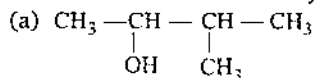

3-methyl-2 butanol

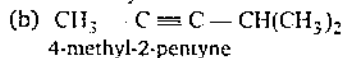

4-methyl-2-pentyne

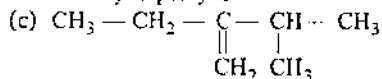

2-ethyl-3 methyl-but-1-ene

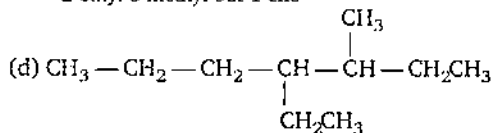

3-methyl-4 ethyl heptane

96. Which one of the following arrangements represents the correct order of electron gain

enthalpy (with negative sign) of the given atomic species ?

- $\text{Cl} < \text{F} < \text{S} < \text{O}$
- $\text{O} < \text{S} < \text{F} < \text{Cl}$
- $\text{S} < \text{O} < \text{Cl} < \text{F}$
- $\text{F} < \text{Cl} < \text{O} < \text{S}$

97. A solution has a 1 : 4 mole ratio of pentane to hexane. The vapour pressure of the pure hydrocarbons at 20°C are 440 mm of Hg for pentane and 120 mm of Hg for hexane. The mole fraction of pentane in the vapour phase would be :

- 0.549
- 0.200
- 0.786
- 0.478

98. 4.5g of aluminium (at. mass 27 amu) is deposited at cathode from Al^{3+} solution by a certain quantity of electric charge. The volume of hydrogen produced at STP from H^+ ions in solution by the same quantity of electric charge will be :

- 22.4 L
- 44.8 L
- 5.6 L
- 11.2 L

99. The best method for the separation of naphthalene and benzoic acid from their mixture is :

- chromatography
- crystallisation
- distillation
- sublimation

100. The mole fraction of the solute in one molal aqueous solution is :

- 0.027
- 0.036
- 0.018
- 0.009

Biology

101. The main organelle involved in modification and routing of newly synthesized proteins to their destinations is :

- mitochondria
- endoplasmic reticulum
- lysosome
- chloroplast

102. There are two opposing views about origin of Modern man. According to one view *Homo erectus* in Asia were the ancestors of modern man. A study of variations of DNA however suggested African origin of Modern man. What kind of observation on DNA variation could suggest this ?

- Greater variation in Africa than in Asia

- Variation only in Asia and no variation in Africa

- Greater variation in Asia than in Africa
- Similar variation in Africa and Asia

103. The world's highly prized wool yielding 'Pashmina' breed is :

- sheep
- goat
- goat-sheep cross
- Kashmir sheep-Afghan sheep cross

104. Grey crescent is the area :

- at the point of entry of sperm into ovum
- just opposite to the site of entry of sperm into ovum
- at the animal pole
- at the vegetal pole

105. Photosynthesis in C_4 plants is relatively less limited by atmospheric CO_2 levels because :
- four carbon acids are the primary initial CO_2 fixation products
 - the primary fixation of CO_2 is mediated via PEP carboxylase
 - effective pumping of CO_2 into bundle sheath cells
 - RUBISCO in C_4 plants has higher affinity for CO_2
106. At what stage of the cell cycle are histone proteins synthesized in a eukaryotic cell ?
- During entire prophase
 - During telophase
 - During S-phase
 - During G_2 stage of prophase
107. There exists a close association between the alga and the fungus within a lichen. The fungus :
- fixes the atmospheric nitrogen for the alga
 - provides protection, anchorage and absorption for the alga
 - provides food for the alga
 - releases oxygen for the alga
108. For retting of jute the fermenting microbe used is :
- Helicobacter pylori*
 - Methophilic bacteria
 - Streptococcus lactin*
 - Butyric acid bacteria
109. A student wishes to study the cell structure under a light microscope having 10X eyepiece and 45X objective. He should illuminate the object by which one of the following colours of light so as to get the best possible resolution ?
- Yellow
 - Green
 - Blue
 - Red
110. The net pressure gradient that causes the fluid to filter out of the glomeruli into the capsule is :
- 20 mm Hg
 - 75 mm Hg
 - 30 mm Hg
 - 50 mm Hg
111. At which latitude, heat gain through insolation approximately equals heat loss through terrestrial radiation ?
- 66° North and South
 - $22\frac{1}{2}^\circ$ North and South
 - 40° North and South
 - $42\frac{1}{2}^\circ$ North and South
112. A man and a woman, who do not show any apparent signs of a certain inherited disease, have seven children (2 daughters and 5 sons). Three of the sons suffer from the given disease but none of the daughters are affected. Which of the following mode of inheritance do you suggest for this disease ?
- Autosomal dominant
 - Sex-linked dominant
 - Sex-limited recessive
 - Sex-linked recessive
113. In Ornithine cycle, which of the following wastes are removed from the blood ?
- Urea and urine
 - Ammonia and urea
 - CO_2 and ammonia
 - CO_2 and urea
114. Telomerase is an enzyme which is a :
- repetitive DNA
 - RNA
 - simple protein
 - ribonucleoprotein
115. During transcription holoenzyme RNA polymerase binds to a DNA sequence and the DNA assumes a saddle like structure at that point. What is that sequence called ?
- CAAT box
 - GGTT box
 - AAAT box
 - TATA box
116. Centromere is required for :
- transcription
 - crossing over
 - cytoplasmic cleavage
 - movement of chromosomes towards poles
117. Damage to thymus in a child may lead to :
- a reduction in haemoglobin content of blood
 - a reduction in stem cell production
 - loss of antibody mediated immunity
 - loss of cell mediated immunity
118. Prolonged liberal irrigation of agricultural fields is likely to create the problem of :
- acidity
 - aridity
 - metal toxicity
 - salinity
119. Chlorophyll in chloroplasts is located in :
- grana
 - pyrenoid
 - stroma
 - both (a) and (c)
120. Three crops that contribute maximum to global food grain production are :
- wheat, rice and maize
 - wheat, maize and sorghum
 - rice, maize and sorghum
 - wheat, rice and barley

121. Genes for cytoplasmic male sterility in plants are generally located in :
 (a) mitochondrial genome
 (b) cytosol
 (c) chloroplast genome
 (d) nuclear genome
122. Which one of the following hydrolyses internal phosphodiester bonds in a polynucleotide chain ?
 (a) Lipase (b) Exonuclease
 (c) Endonuclease (d) Protease
123. Match items in column-I with those in column-II.
- | Column-I | Column-II |
|------------------------------|----------------------------|
| A. Peritrichous flagellation | 1. <i>Ginkgo</i> |
| B. Living fossil | 2. <i>Macrocystes</i> |
| C. Rhizophore | 3. <i>Escherichia coli</i> |
| D. Smallest flowering plant | 4. <i>Selaginella</i> |
| E. Largest perennial alga | 5. <i>Wolffia</i> |
- Select the correct answer from the following :
Codes :
- | A | B | C | D | E | A | B | C | D | E |
|-------|---|---|---|---|-------|---|---|---|---|
| (a) 2 | 1 | 3 | 4 | 5 | (b) 5 | 3 | 2 | 5 | 1 |
| (c) 1 | 2 | 5 | 3 | 2 | (d) 3 | 1 | 4 | 5 | 2 |
124. The name of Norman Borlaug is associated with :
 (a) Green revolution
 (b) Yellow revolution
 (c) White revolution
 (d) Blue revolution
125. G-6-P dehydrogenase deficiency is associated with haemolysis of :
 (a) lymphocytes (b) RBCs
 (c) platelets (d) leucocytes
126. In which one pair both the plants can be vegetatively propagated by leaf pieces ?
 (a) *Bryophyllum* and *Kalanchoe*
 (b) *Chrysanthemum* and *Agave*
 (c) *Agave* and *Kalanchoe*
 (d) *Asparagus* and *Bryophyllum*
127. According to IUCN red list what is the status of red Panda (*Ailurus fulgens*) ?
 (a) Vulnerable species
 (b) Critically endangered species
 (c) Extinct species
 (d) Endangered species
128. Which of the following substances, if introduced in the blood stream, would cause coagulation, at the site of its introduction ?
 (a) Fibrinogen
 (b) Prothrombin
 (c) Heparin
 (d) Thromboplastin
129. *E. coli* cells with a mutated Z gene of the lac operon cannot grow in medium containing only lactose as the source of energy because :
 (a) in the presence of glucose, *E. coli* cells do not utilize lactose
 (b) they cannot transport lactose from the medium into the cell
 (c) the lac operon is constitutively active in these cells
 (d) they cannot synthesize functional β -galactosidase
130. Top-shaped multiciliate male gametes and the mature seed which bears only one embryo with two cotyledons, are characteristic features of :
 (a) polypetalous angiosperms
 (b) gamopetalous angiosperms
 (c) conifers
 (d) cycads
131. Production of a human protein in bacteria by genetic engineering is possible because :
 (a) bacterial cell can carry out the RNA splicing reactions
 (b) the human chromosome can replicate in bacterial cell
 (c) the mechanism of gene regulation is identical in humans and bacteria
 (d) the genetic code is universal
132. From the following statements select the wrong one :
 (a) millepedes have two pairs of appendages in each segment of the body
 (b) prawn has two pairs of antennae
 (c) animals belonging to phylum-Porifera are exclusively marine
 (d) nematocysts are characteristic of the phylum-Cnidaria
133. Nucleotide are building blocks of nucleic acids, nucleotide is a composite molecule formed by :
 (a) (base-sugar-phosphate)_n
 (b) base-sugar-OH
 (c) base-sugar-phosphate
 (d) sugar-phosphate

134. More than 70% of world's freshwater is contained in :
- Antarctica
 - Glaciers and Mountains
 - Greenland
 - Polar ice
135. Which one of the following pairs is mismatched ?
- Biomass burning—release of CO_2
 - Fossil fuel burning—release of CO_2
 - Nuclear power—radioactive wastes
 - Solar energy—green house effect
136. Which one of the following characters is not typical of the class-mammalia ?
- Seven cervical vertebrae
 - Thecodont dentition
 - Ten pairs of cranial nerves
 - Alveolar lungs
137. Which of the following is the simplest amino acid ?
- Tyrosine
 - Asparagine
 - Glycine
 - Alanine
138. Barophilic prokaryotes :
- grow slowly in highly alkaline frozen lakes at high altitudes
 - occur in water containing high concentrations of barium hydroxide
 - grow and multiply in very deep marine sediments
 - readily grown and divides in sea water enriched in any soluble salt of barium
139. Auxospores and hormocysts are formed, respectively, by :
- several diatoms and a few cyanobacteria
 - several cyanobacteria and several diatoms
 - some diatoms and several cyanobacteria
 - some cyanobacteria and many diatoms
140. Enzymes, vitamins and hormones can be classified into a single category of biological chemicals, because all of these :
- enhance oxidative metabolism
 - are conjugated proteins
 - are exclusively synthesized in the body of a living organism as at present
 - help in regulating metabolism
141. Which one of the following phenomena supports Darwin's concept of natural selection in organic evolution ?
- Development of transgenic animals
 - Production of 'Dolly' the sheep by cloning
 - Prevalence of pesticide resistant insects
 - Development of organs from 'stem cells' for organ transplantation
142. As compared to a C_3 plant, how many additional molecules of ATP are needed for net production of one molecule of hexose sugar by C_4 plants :
- 2
 - 6
 - 0
 - 12
143. In a man, abducens nerve is injured. Which one of the following functions will be affected ?
- Movement of the eye ball
 - Swallowing
 - Movement of the tongue
 - Movement of the neck
144. An important step in the manufacture of pulp for paper industry from the woody tissues of plants is the :
- preparation of pure cellulose by removing lignin
 - removal of oils present in the wood by treatment with suitable chemicals
 - removal of water from the wood by prolonged heating at approximately 50°C
 - treatment of wood with chemical that breakdown cellulose
145. Protein synthesis in an animal cell occurs :
- only on the ribosomes present in cytosol
 - on ribosomes present in cytoplasm as well as in mitochondria
 - only on ribosomes attached to the nuclear envelope and endoplasmic reticulum
 - on ribosomes present in the nucleolus as well as in cytoplasm
146. Which of the following is not true for a species ?
- Members of a species can interbreed
 - Variations occurs among members of a species
 - Each species is reproductively isolated from every other species
 - Gene flow does not occur between the populations of a species
147. One of the most important functions of botanical gardens is that :
- one can observe tropical plants there
 - they allow *ex situ* conservation of germplasm
 - they provide the natural habitat for wild life
 - they provide a beautiful area for recreation

148. The ability of the venus flytrap to capture insects is due to :
- chemical stimulation by the prey
 - a passive process requiring no special ability on the part of the plant
 - specialized "muscle-like" cells
 - rapid turgor pressure changes
149. Animals have the innate ability to escape from predation. Examples for the same are given below. Select the incorrect example :
- enlargement of body size by swallowing air in puffer fish
 - melanism in moths
 - poison fangs in snakes
 - colour change in chameleon
150. At a particular locus, frequency of 'A' allele is 0.6 and that of 'a' is 0.4. What would be the frequency of heterozygotes in a random mating population at equilibrium ?
- 0.16
 - 0.48
 - 0.36
 - 0.24
151. Which one of the following experiments suggests that simplest living organisms could not have originated spontaneously from non-living matter ?
- Microbes did not appear in stored meat
 - Larvae could appear in decaying organic matter
 - Microbes appeared from unsterilized organic matter
 - Meat was not spoiled, when heated and kept sealed in a vessel
152. Biodiversity act of India was passed by the Parliament in the year :
- 1996
 - 1992
 - 2002
 - 2000
153. During which stage in the complete oxidation of glucose are the greatest number of ATP molecules formed from ADP ?
- Conversion of pyruvic acid to acetyl Co-A
 - Electron transport chain
 - Glycolysis
 - Krebs cycle
154. A woman with normal vision, but whose father was colour blind, marries a colourblind man. Suppose that the fourth child of this couple was a boy. This boy :
- must have normal colour vision
 - will be partially colourblind since he is heterozygous for the colourblind mutant allele
 - must be colourblind
 - may be colourblind or may be of normal vision
155. Ectophloic siphonostele is found in :
- Adiantum* and Cucurbitaceae
 - Osmunda* and *Equisetum*
 - Marsilea* and *Botrychium*
 - Dicksonia* and maiden hair fern
156. Which of the following represents the edible part of the fruit of litchi ?
- Pericarp
 - Mesocarp
 - Juicy aril
 - Endocarp
157. Carbohydrates, the most abundant biomolecules on earth, are produced by :
- all bacteria, fungi and algae
 - fungi, algae and green plant cells
 - some bacteria, algae and green plant cells
 - viruses, fungi and bacteria
158. Identify the correctly matched pair :
- Montreal protocol - Global warming
 - Kyoto protocol - Climatic change
 - Ramsar convention - Ground water pollution
 - Basal convention - Biodiversity conservation
159. Which of the following is not a hereditary disease ?
- Cretinism
 - Cystic fibrosis
 - Thalassaemia
 - Haemophilia
160. The deficiencies of micro-nutrients, not only affects growth of plants but also vital functions such as photosynthetic and mitochondrial electron flow. Among the list given below, which group of three elements shall affect most, both photosynthetic and mitochondrial electron transport ?
- Cu, Mn, Fe
 - Co, Ni, Mo
 - Mn, Co, Ca
 - Ca, K, Na
161. de Vries gave his mutation theory on organic evolution while working on :
- Althea rosea*
 - Drosophila melanogaster*
 - Oenothera lamarckiana*
 - Pisum sativum*
162. One of the examples of the action of the autonomous nervous system is :
- knee-jerk response
 - pupillary reflex
 - swallowing of food
 - peristalsis of the intestines

163. Which of the following is not used for disinfection of drinking water ?
(a) Phenyl (b) Chloramine
(c) Chlorine (d) Ozone
164. Chemiosmotic theory of ATP synthesis in the chloroplasts and mitochondria is based on :
(a) proton gradient
(b) accumulation of K ions
(c) accumulation of Na ions
(d) membrane potential
165. Parkinson's disease (characterized by tremors and progressive rigidity of limbs) is caused by degeneration of brain neurons that are involved in movement control and make use of neurotransmitter :
(a) acetylcholine (b) norepinephrine
(c) dopamine (d) GABA
166. All of the following statements concerning the actinomycetous filamentous soil bacterium *Frankia* are correct except that *Frankia* :
(a) can induce root nodules on many plant species
(b) can fix nitrogen in the free-living state
(c) like *Rhizobium*, it usually infects its host plant through root hair deformation and stimulates cell proliferation in the host's cortex
(d) forms specialized vesicles in which the nitrogenase is protected from oxygen by a chemical barrier involving triterpene hopanoids
167. An acromian process is characteristically found in the :
(a) pelvic girdle of mammals
(b) skull of frog
(c) pectoral girdle of mammals
(d) sperm of mammals
168. In a type of apomixis known as adventive embryony, embryos develop directly from the :
(a) nucellus or integuments
(b) synergids or antipodals in an embryo sac
(c) accessory embryo sacs in the ovule
(d) zygote
169. Through which cell of the embryo sac, does the pollen tube enter the embryo sac ?
(a) Egg cell
(b) Central cell
(c) Persistent synergid
(d) Degenerated synergid
170. Epithelial cells of the intestine involved in food absorption have on their surface :
(a) pinocytotic vesicles
(b) phagocytotic vesicles
(c) zymogen granules
(d) micro-villi
171. A patient is generally advised to specially, consume more meat, lentils, milk and eggs in diet only when he suffers from :
(a) kwashiorkor (b) rickets
(c) anaemia (d) scurvy
172. Which one of the following pairs is mismatched ?
(a) Savanna — Acacia trees
(b) Prairie — epiphytes
(c) Tundra — permafrost
(d) Coniferous forest — evergreen trees
173. Which of the following is the relatively most accurate method for dating of fossils ?
(a) Potassium - argon method
(b) Uranium - lead method
(c) Electron - spin resonance method
(d) Radio - carbon method
174. Which one of the following represents an ovule, where the embryo sac becomes horse-shoe shaped and the funiculus and micropyle are close to each other ?
(a) Circinotropous (b) Anatropous
(c) Amphitropous (d) Atropous
175. Potometer works on the principle of :
(a) amount of water absorbed equals the amount transpired
(b) osmotic pressure
(c) root pressure
(d) potential difference between the tip of the tube and that of the plant
176. In a woody dicotyledonous tree, which of the following parts will mainly consist of primary tissues ?
(a) Stem and root
(b) All parts
(c) Shoot tips and root tips
(d) Flowers, fruits and leaves
177. Which one of the following makes use of RNA as a template to synthesize DNA ?
(a) Reverse transcriptase
(b) DNA dependant RNA polymerase
(c) DNA polymerase
(d) RNA polymerase

178. In contrast to annelids the platyhelminths show :
- radial symmetry
 - presence of pseudocoel
 - bilateral symmetry
 - absence of body cavity
179. Which of the following statements regarding enzyme inhibition is correct ?
- Non-competitive inhibition of an enzyme can be overcome by adding large amount of substrate
 - Competitive inhibition is seen when a substrate competes with an enzyme for binding to an inhibitor protein
 - Competitive inhibition is seen when the substrate and the inhibitor compete
 - Non-competitive inhibitors often bind to the enzyme irreversibly
180. Which of the following pairs is correctly matched ?
- Cartilaginous joint — skull bones joint
 - Hinge joint — between vertebrae
 - Fibrous joint — between phalanges
 - Gliding joint — between zygapophyses of the successive vertebrae
181. The catalytic efficiency of two different enzymes can be compared by the :
- the K_m value
 - the pH optimum value
 - formation of the product
 - molecular size of the enzyme
182. Using imprints from a plate with complete medium and carrying bacterial colonies, you can select streptomycin resistant mutants and prove that such mutations do not originate as adaptation. These imprints need to be used :
- only on plates with streptomycin
 - on plates with minimal medium
 - only on plates without streptomycin
 - on plates with and without streptomycin
183. Which of the following is generally used for induced mutagenesis in crop plants ?
- Alpha particles
 - X-rays
 - UV (260 nm)
 - Gamma rays (from cobalt 60)
184. Haemophilia is more commonly seen in human males than in human females because :
- this disease is due to an X-linked dominant mutation
 - a greater proportion of girls die in infancy
 - this disease is due to an X-linked recessive mutation
 - this disease is due to a Y-linked recessive mutation
185. A woman with 47 chromosomes due to three copies of chromosome 21 is characterized by :
- Down syndrome
 - triploidy
 - Turner syndrome
 - super femaleness
186. In order to find out the different types of gametes produced by a pea plant having the genotype AaBb, it should be crossed to a plant with the genotype :
- aaBB
 - AaBb
 - AABB
 - aabb
187. Four healthy people in their twenties got involved in injuries resulting in damage and death of a few cells of the following. Which of the cells are least likely to be replaced by new cells ?
- Osteocytes
 - Malpighian layer of the skin
 - Liver cells
 - Neurons
188. Secretin and cholecystokinin are digestive hormones. They are secreted in :
- oesophagus
 - ileum
 - duodenum
 - pyloric stomach
189. Which of the following unicellular organism has a macro-nucleus for trophic function and one or more micro-nuclei for reproduction ?
- Euglena*
 - Amoeba*
 - Paramecium*
 - Trypanosoma*
190. AIDS is caused by HIV that principally infects :
- all lymphocytes
 - activator B cells
 - T_4 lymphocytes
 - cytotoxic T cells
191. According to widely accepted "fluid mosaic model" cell membranes are semi-fluid, where lipids and integral proteins can diffuse randomly. In recent years, this model has been modified in several respects. In this regard, which of the following statements is incorrect ?
- Proteins in cell membranes can travel within the lipid bilayer
 - Proteins can remain confined within certain domains of the membrane
 - Proteins can also undergo flip-flop movements in the lipid bilayer
 - Many proteins remain completely embedded within the lipid bilayer

192. If mammalian ovum fails to get fertilized, which one of the following is unlikely ?
 (a) Corpus luteum will disintegrate
 (b) Estrogen secretion further decreases
 (c) Primary follicle starts developing
 (d) Progesterone secretion rapidly declines
193. A person is undergoing prolonged fasting. His urine will be found to contain abnormal quantities of :
 (a) fats (b) ketones
 (c) amino acids (d) glucose
194. Why is vivipary an undesirable character for annual crop plants ?
 (a) It reduces the vigour of plant
 (b) The seeds cannot be stored under normal conditions for the next season
 (c) The seeds exhibit long dormancy
 (d) It adversely affects the fertility of the plant
195. *Bacillus thuringiensis* (Bt) strains have been used for designing novel :
 (a) bio-metallurgical technique
 (b) bio-mineralization processes
 (c) bio-insecticidal plants
 (d) bio-fertilizers
196. The salivary gland chromosomes in the dipteran larvae, are useful in gene mapping because :
 (a) these are much longer in size
 (b) these are easy to stain
 (c) these are fused
 (d) they have endoreduplicated chromosomes
197. Which group of three of the following five statements (1-5) contain is all three correct statements regarding beri-beri ?
- A. A crippling disease prevalent among the native population of sub-Sahara Africa.
 B. A deficiency disease caused by lack of thiamine (vitamin B₁).
 C. A nutritional disorder in infants and young children when the diet is persistently deficient in essential protein.
 D. Occurs in those countries where the staple diet is polished rice.
 E. The symptoms are pain from neuritis, paralysis, muscle wasting, progressive oedema, mental deterioration and finally heart failure.
 (a) A, B and D (b) B, C and E
 (c) A, C and E (d) B, D and E
198. Photosynthetic Active Radiation (PAR) has the following range of wavelengths :
 (a) 400 - 700 nm
 (b) 450 - 950 nm
 (c) 340 - 450 nm
 (d) 500 - 600 nm
199. Golden rice is a transgenic crop of the future with the following improved trait :
 (a) high lysine (essential amino acid) content
 (b) insect resistance
 (c) high protein content
 (d) high vitamin A content
200. Which one of the following depresses brain activity and produces feelings of calmness, relaxation and drowsiness ?
 (a) Valium
 (b) Morphine
 (c) Hashish
 (d) Amphetamines

ANSWERS

➔ PHYSICS

- | | | | | | | | | | |
|---------|---------|---------|---------|---------|---------|---------|---------|---------|---------|
| 1. (c) | 2. (c) | 3. (a) | 4. (b) | 5. (a) | 6. (a) | 7. (b) | 8. (b) | 9. (b) | 10. (d) |
| 11. (b) | 12. (c) | 13. (a) | 14. (a) | 15. (a) | 16. (b) | 17. (d) | 18. (d) | 19. (a) | 20. (d) |
| 21. (c) | 22. (d) | 23. (b) | 24. (a) | 25. (d) | 26. (a) | 27. (a) | 28. (c) | 29. (c) | 30. (c) |
| 31. (b) | 32. (c) | 33. (c) | 34. (c) | 35. (d) | 36. (b) | 37. (a) | 38. (a) | 39. (c) | 40. (b) |
| 41. (d) | 42. (d) | 43. (c) | 44. (d) | 45. (d) | 46. (d) | 47. (d) | 48. (d) | 49. (b) | 50. (b) |

→ CHEMISTRY

51. (b)	52. (c)	53. (d)	54. (d)	55. (d)	56. (c)	57. (d)	58. (a)	59. (c)	60. (b)
61. (d)	62. (d)	63. (a)	64. (d)	65. (b)	66. (b)	67. (a)	68. (c)	69. (d)	70. (c)
71. (d)	72. (a)	73. (d)	74. (a)	75. (a)	76. (a)	77. (a)	78. (b)	79. (c)	80. (d)
81. (c)	82. (a)	83. (b)	84. (d)	85. (d)	86. (b)	87. (c)	88. (a)	89. (a)	90. (c)
91. (b)	92. (d)	93. (a)	94. (a)	95. (d)	96. (b)	97. (d)	98. (c)	99. (d)	100. (c)

→ BIOLOGY

101. (b)	102. (c)	103. (b)	104. (b)	105. (b)	106. (c)	107. (b)	108. (d)	109. (c)	110. (a)
111. (c)	112. (d)	113. (c)	114. (d)	115. (d)	116. (d)	117. (d)	118. (d)	119. (a)	120. (a)
121. (a)	122. (c)	123. (d)	124. (a)	125. (b)	126. (a)	127. (d)	128. (d)	129. (d)	130. (d)
131. (d)	132. (b)	133. (c)	134. (d)	135. (d)	136. (c)	137. (c)	138. (c)	139. (a)	140. (d)
141. (c)	142. (d)	143. (a)	144. (a)	145. (b)	146. (d)	147. (b)	148. (d)	149. (c)	150. (b)
151. (d)	152. (c)	153. (b)	154. (d)	155. (b)	156. (c)	157. (c)	158. (b)	159. (a)	160. (a)
161. (c)	162. (d)	163. (a)	164. (a)	165. (c)	166. (b)	167. (c)	168. (a)	169. (d)	170. (d)
171. (a)	172. (b)	173. (c)	174. (c)	175. (a)	176. (c)	177. (a)	178. (d)	179. (c)	180. (d)
181. (a)	182. (a)	183. (d)	184. (c)	185. (a)	186. (d)	187. (d)	188. (c)	189. (c)	190. (c)
191. (c)	192. (b)	193. (b)	194. (b)	195. (c)	196. (d)	197. (d)	198. (a)	199. (d)	200. (a)

HINTS & SOLUTIONS

Physics

1. Torque acting on equilateral triangle in a magnetic field \vec{B} is

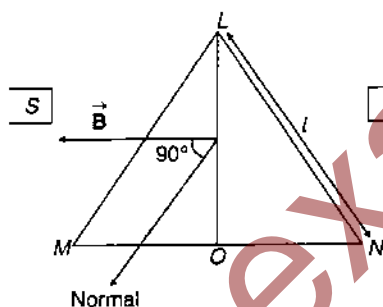

$$\tau = iAB \sin \theta$$

Area of triangle LMN

$$A = \frac{\sqrt{3}}{4} l^2 \quad \text{and} \quad \theta = 90^\circ$$

Substituting the given values in the expression for torque, we have

$$\tau = i \times \frac{\sqrt{3}}{4} l^2 B \sin 90^\circ$$

$$= \frac{\sqrt{3}}{4} i l^2 B \quad (\because \sin 90^\circ = 1)$$

$$\text{Hence, } l = 2 \left(\frac{\tau}{\sqrt{3} Bi} \right)^{1/2}$$

2. It is clear that the two cells oppose each other hence, the effective emf in closed circuit is $18 - 12 = 6 \text{ V}$ and net resistance is $1 + 2 = 3 \Omega$ (because in the closed circuit the internal resistances of two cells are in series).

The current in circuit will be in direction of arrow shown in figure.

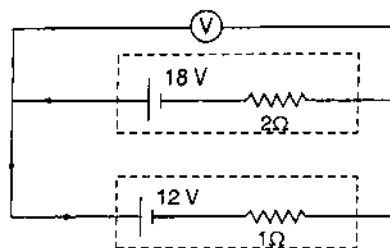

$$I = \frac{\text{effective emf}}{\text{total resistance}} = \frac{6}{3} = 2 \text{ A}$$

The potential difference across V will be same as the terminal voltage of either cell.

Since, current is drawn from the cell of 18 volt, hence,

$$V_1 = E_1 - ir_1 \\ = 18 - (2 \times 2) = 18 - 4 = 14 \text{ V}$$

Similarly, current enters in the cell of 12 V, hence,

$$V_2 = E_2 + ir_2 \\ = 12 + 2 \times 1 \\ = 12 + 2 = 14 \text{ V}$$

Hence, $V = 14 \text{ V}$

3. **Key Idea** : The average power per unit area that is incident perpendicular to the direction of propagation is called the intensity.

Intensity of sound

$$I = \frac{P}{4\pi r^2}$$

or $I \propto \frac{1}{r^2}$

or $\frac{I_1}{I_2} = \left(\frac{r_2}{r_1}\right)^2$

Here, $r_1 = 2 \text{ m}$, $r_2 = 3 \text{ m}$

Substituting the values, we have

$$\frac{I_1}{I_2} = \left(\frac{3}{2}\right)^2 = \frac{9}{4}$$

NOTE : As amplitude $A \propto \sqrt{I}$, a spherical harmonic wave emanating from a point source can therefore, be written as :

$$y(r, t) = \frac{A}{r} \sin(kr - \omega t)$$

4. **Key Idea** : The linear momentum of exploding part will remain conserved.

Applying conservation of linear momentum, we write,

$$m_1 u_1 = m_2 u_2$$

Here, $m_1 = 18 \text{ kg}$, $m_2 = 12 \text{ kg}$

$$u_1 = 6 \text{ ms}^{-1}, u_2 = ?$$

$$\therefore 18 \times 6 = 12 u_2$$

$$\Rightarrow u_2 = \frac{18 \times 6}{12} = 9 \text{ ms}^{-1}$$

Thus, kinetic energy of 12 kg mass

$$K_2 = \frac{1}{2} m_2 u_2^2$$

$$= \frac{1}{2} \times 12 \times (9)^2$$

$$= 6 \times 81$$

$$= 486 \text{ J}$$

5. When a body rolls down without slipping along an inclined plane of inclination θ , it rotates about a horizontal axis through its centre of mass and also its centre of mass moves. Therefore, rolling motion may be regarded as a rotational motion about an axis through its centre of mass plus a translational motion of the centre of mass. As it rolls down, it suffers loss in gravitational potential energy provided translational energy due to frictional force is converted into rotational energy.

NOTE : In fact, friction is needed to cause the body to roll. However the rolling friction is so small that we can use conservation of mechanical energy.

6. The acceleration due to gravity on the new planet can be found using the relation

$$g = \frac{GM}{R^2} \quad \dots(i)$$

but $M = \frac{4}{3} \pi R^3 \rho$, ρ being density.

Thus, Eq. (i) becomes

$$\therefore g = \frac{G \times \frac{4}{3} \pi R^3 \rho}{R^2}$$

$$= G \times \frac{4}{3} \pi R \rho$$

$$\Rightarrow g \propto R$$

$$\therefore \frac{g'}{g} = \frac{R'}{R}$$

$$\Rightarrow \frac{g'}{g} = \frac{3R}{R} = 3$$

$$\Rightarrow g' = 3g$$

7. **Key Idea** : Charge on a capacitor is the product of capacitance and potential difference across it.

The charge flowing through C_4 is

$$q_4 = C_4 \times V = 4CV$$

The series combination of C_1 , C_2 and C_3 gives

$$\frac{1}{C'} = \frac{1}{C} + \frac{1}{2C} + \frac{1}{3C}$$

$$= \frac{6 + 3 + 2}{6C} = \frac{11}{6C}$$

$$\Rightarrow C' = \frac{6C}{11}$$

Now, C' and C_4 form parallel combination giving

$$C'' = C' + C_4 = \frac{6C}{11} + 4C = \frac{50C}{11}$$

Net charge $q = C''V$

$$= \frac{50}{11} CV$$

Total charge flowing through C_1, C_2, C_3 will be

$$q' = q - q_4 = \frac{50}{11} CV - 4CV = \frac{6CV}{11}$$

Since, C_1, C_2 and C_3 are in series combination hence, charge flowing through these will be same.

Hence,

$$q_2 = q_1 = q_3 = q' = \frac{6CV}{11}$$

$$\text{Thus, } \frac{q_2}{q_4} = \frac{6CV/11}{4CV} = \frac{3}{22}$$

8. **Key Idea :** Heat conduction through a rod is rate of change of heat $\left(\frac{\Delta Q}{\Delta t}\right)$.

$$\therefore H = \frac{\Delta Q}{\Delta t} = KA \left(\frac{T_1 - T_2}{l}\right)$$

$$\Rightarrow H \propto \frac{r^2}{l} \quad \dots(i)$$

(a) When $r = 2r_0; l = 2l_0$

$$H \propto \frac{(2r_0)^2}{2l_0}$$

$$\Rightarrow H \propto \frac{2r_0^2}{l_0}$$

(b) When $r = r_0; l = l_0$

$$H \propto \frac{r_0^2}{l_0}$$

$$\Rightarrow H \propto \frac{4r_0^2}{l_0}$$

(c) When $r = r_0; l = l_0$

$$H \propto \frac{r_0^2}{l_0}$$

(d) When $r = r_0; l = 2l_0$

$$H \propto \frac{r_0^2}{2l_0}$$

It is obvious that heat conduction will be more in case (b).

NOTE : It is fact that the temperature of whole rod does not become equal when heat is being continuously supplied due to the reason that temperature difference in the rod for the heat flow is

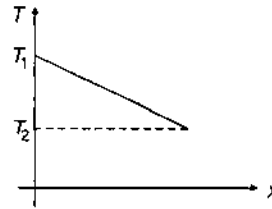

same as we require a potential difference across a resistance for the current flow through it.

9. **Key Idea :** The energy released per nuclear reaction is the resultant binding energy.

Binding energy of $({}^2_1\text{H} + {}^3_1\text{H}) = a + b$

Binding energy of ${}^4_2\text{He} = c$

In a nuclear reaction the resultant nucleus is more stable than the reactants. Hence, binding energy of ${}^4_2\text{He}$ will be more than that of $({}^2_1\text{H} + {}^3_1\text{H})$.

Thus, energy released per nucleon = resultant binding energy = $c - (a + b) = c - a - b$

NOTE : Out of the elements present in periodic table, Fe(56) has maximum binding energy. Hence, it is most stable.

10. **Key Idea :** At point P, Maxwell cork screw rule defines the direction of magnetic field and Fleming's left hand rule reveal the concept of force on the charge in this field.

According to Maxwell's cork screw rule the direction of magnetic field at point P in plane of paper is perpendicular to the plane of paper inwards i.e., along z-direction.

Now since charge is moving along x-direction therefore, from Fleming's left hand rule stretching the forefinger in direction of paper inwards the thumb will indicate the direction of force F acting on the charged particle along oy.

Alternative : As discussed above, B acts inwards into plane of the paper and v is along ox hence,

$$F = Q(\vec{v} \times \vec{B}) = Q \begin{vmatrix} \hat{i} & \hat{j} & \hat{k} \\ v & 0 & 0 \\ 0 & 0 & -B \end{vmatrix}$$

$$= Q[\hat{i}(0) - \hat{j}(-vB) + \hat{k}(0)]$$

$$= +\hat{j}QvB$$

i.e., force is along oy direction.

11. From the energy level diagram as shown below:

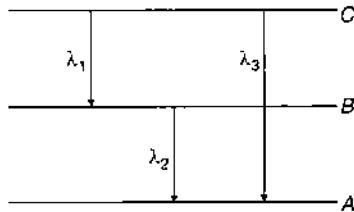

$$\frac{1}{\lambda_3} = \frac{1}{\lambda_1} + \frac{1}{\lambda_2}$$

$$= \frac{\lambda_2 + \lambda_1}{\lambda_1 \lambda_2}$$

$$\Rightarrow \lambda_3 = \frac{\lambda_1 \lambda_2}{\lambda_1 + \lambda_2}$$

12. **Key Idea :** That metal will emit photoelectrons which has work function lower than that obtained with the radiation of 4100 \AA .

Work function for wavelength of 4100 \AA is

$$W = \frac{hc}{\lambda}$$

$$= \frac{6.62 \times 10^{-34} \times 3 \times 10^8}{4100 \times 10^{-10}}$$

$$= 4.8 \times 10^{-19} \text{ J}$$

$$= \frac{4.8 \times 10^{-19}}{1.6 \times 10^{-19}} \text{ eV} = 3 \text{ eV}$$

Now, we have

$$W_A = 1.92 \text{ eV,}$$

$$W_B = 2.0 \text{ eV,}$$

$$W_C = 5 \text{ eV}$$

Since, $W_A < W$ and $W_B < W$, hence, A and B will emit photoelectrons.

13. The nuclei which have same number of neutrons but different atomic number and mass number are known as isotones. In choice (a) nuclei of ${}_{34}\text{Se}^{74}$ and ${}_{31}\text{Ga}^{71}$ are isotones as
- $$A - Z = 74 - 34 = 40$$

14. **Key Idea :** The work done in carrying a test charge consists in product of difference of potentials at points A and B and value of test charge.

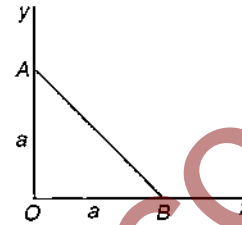

Potential at A

$$V_A = \frac{1}{4\pi\epsilon_0} \frac{q}{a}$$

Potential at B

$$V_B = \frac{1}{4\pi\epsilon_0} \frac{q}{a}$$

Thus, work done in carrying a test charge $-Q$ from A to B

$$W = (V_A - V_B)(-Q) = 0$$

15. Induced emf

$$= \frac{\text{work done in taking a charge } Q \text{ once along the loop}}{\text{charge } Q}$$

$$\text{i.e., } V = \frac{W}{Q}$$

$$\Rightarrow W = VQ$$

16. The circuit given resembles the balanced Wheatstone Bridge as $\frac{4}{6} = \frac{2}{3}$.

Thus, middle arm containing 4Ω resistance will be ineffective and no current flows through it.

The equivalent circuit is shown as below :

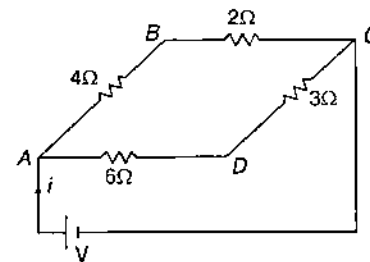

Net resistance of AB and BC

$$R' = 4 + 2 = 6\Omega$$

Net resistance of AD and DC

$$R'' = 6 + 3 = 9 \Omega$$

Thus, parallel combination of R' and R'' gives

$$R = \frac{R' \times R''}{R' + R''} \\ = \frac{6 \times 9}{6 + 9} = \frac{54}{15} = \frac{18}{5} \Omega$$

$$\text{Hence, current } i = \frac{V}{R} = \frac{V}{18/5} = \frac{5V}{18}$$

17. In a circular motion particle repeats after equal intervals of time. So, particle motion on a circular path is periodic but not simple harmonic as it does not execute to and fro motion about a fixed point.

NOTE : When a particle moves with uniform circular motion, its projection on a diameter moves with SHM.

18. Maximum speed of a particle executing SHM is

$$u_{\max} = a \omega = a (2\pi n)$$

$$\Rightarrow n = \frac{u_{\max}}{2\pi a}$$

Here, $u_{\max} = 31.4 \text{ cm/s}$, $a = 5 \text{ cm}$

Substituting, the given values, we have

$$n = \frac{31.4}{2 \times 3.14 \times 5} = 1 \text{ Hz}$$

19. $E = h\nu$

$$\Rightarrow h = \text{Planck's constant} = \frac{E}{\nu}$$

$$\therefore [h] = \frac{[E]}{[\nu]} = \frac{[ML^2T^{-2}]}{[T^{-1}]} \\ = [ML^2T^{-1}]$$

and $I = \text{moment of inertia} = MR^2$

$$\Rightarrow [I] = [M][L^2] = [ML^2]$$

$$\text{Hence, } \frac{[h]}{[I]} = \frac{[ML^2T^{-1}]}{[ML^2]} = [T^{-1}] \\ = \frac{1}{[T]} = \text{dimension of frequency}$$

Alternative : $\frac{h}{I} = \frac{E/\nu}{I}$

$$= \frac{E \times T}{I} = \frac{(\text{kg m}^2/\text{s}^2) \times \text{s}}{(\text{kg m}^2)}$$
$$= \frac{1}{\text{s}} = \frac{1}{\text{time}} = \text{frequency}$$

Thus, dimensions of $\frac{h}{I}$ is same as of frequency.

20. (a) It is the process by which heat is transmitted from one place to another without heating the intervening medium. Hence, it is not a reversible process.

(b) Nichrome wire is made of alloys and has high resistance. When current is passed through it, heat is produced. So, here electrical energy is converted into heat energy. Hence, it is not a reversible process.

(c) It is the process by which heat is transmitted from one point to another through a substance in the direction of fall of temperature without the actual movement of the particles of the substances themselves. Hence, it cannot be reversible.

(d) Isothermal compression is reversible, for example-Carnot cycle, Heat engine.

Thus, choice (d) is correct.

21. **Key Idea :** The temperature of inversion is higher than the neutral temperature by the same amount as the neutral temperature is higher than the temperature of cold junction.

As per Key Idea

$$t_n - t_0 = t_i - t_n \\ \Rightarrow t_0 = 2t_n - t_i$$

Given, $t_i = 620^\circ\text{C}$, $t_n = 300^\circ\text{C}$

Hence, $t_0 = \text{temperature of cold junction}$

$$= 2 \times 300 - 620 \\ = 600 - 620 = -20^\circ\text{C}$$

NOTE : Neutral temperature does not change for a metal whether the temperature of cold junction and inversion temperature change by any value.

22. **Key Idea :** The solution to our problem consists in Einstein's photoelectric equation.

Einstein's photoelectric equation can be written as

$$\frac{1}{2}mv^2 = h\nu - \phi \\ \Rightarrow \frac{1}{2}m \times (4 \times 10^6)^2 = 2h\nu_0 - h\nu_0 \quad \dots(i)$$

$$\text{and } \frac{1}{2}m \times v^2 = 5h\nu_0 - h\nu_0 \quad \dots(ii)$$

Dividing Eq. (ii) by (i), we get

$$\frac{v^2}{(4 \times 10^6)^2} = \frac{4h\nu_0}{h\nu_0} \\ \Rightarrow v^2 = 4 \times 16 \times 10^{12} \\ \Rightarrow v^2 = 64 \times 10^{12}$$

$$\therefore v = 8 \times 10^6 \text{ m/s}$$

NOTE : The efficiency of photoelectric effect is less than 1% i.e., number of photons less than 1% are capable of ejecting photoelectrons.

23. The binding energy per nucleon for the middle nuclides (from $A = 20$ to $A = 56$) is maximum. Hence, these are more stable.

As the mass number increases, the binding energy per nucleon gradually decreases and ultimately binding energy per nucleon of heavy nuclides (such as uranium etc.) is comparatively low. Hence, these nuclides are relatively unstable. So, they can be fissioned easily.

24. When p -side of junction diode is connected to positive of battery and n -side to the negative, then junction diode is forward biased.

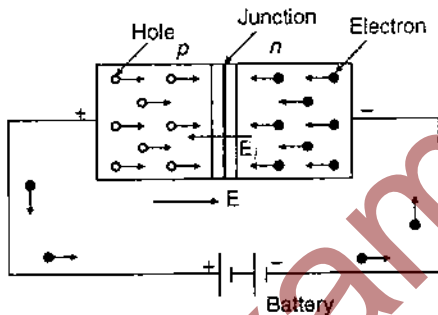

In this condition, more number of electrons enter in n -side from battery thereby increasing the number of donor on n -side.

NOTE : The curves for charge density, electric field and potential barrier for a p - n junction are as shown in figure below :

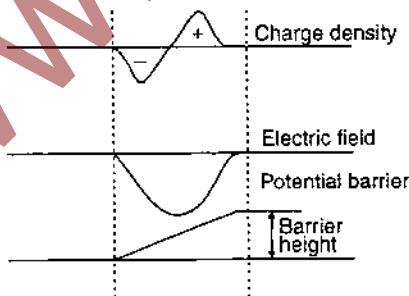

25. Given,

$$x = ae^{-at} + be^{bt}$$

$$\text{So, velocity } v = \frac{dx}{dt}$$

$$= -a ae^{-at} + b be^{bt}$$

$$= A + B$$

$$\text{where, } A = -a ae^{-at}, B = b be^{bt}$$

The value of term $A = -a ae^{-at}$ decreases and of term $B = b be^{bt}$ increases with increase in time. As a result, velocity goes on increasing with time.

26. **Key Idea :** The change in potential energy of the system is $U_D - U_C$ as discussed under.

When charge q_3 is at C, then its potential energy is

$$U_C = \frac{1}{4\pi\epsilon_0} \left(\frac{q_1 q_3}{0.4} + \frac{q_2 q_3}{0.5} \right)$$

When charge q_3 is at D, then

$$U_D = \frac{1}{4\pi\epsilon_0} \left(\frac{q_1 q_3}{0.4} + \frac{q_2 q_3}{0.1} \right)$$

Hence, change in potential energy

$$\begin{aligned} \Delta U &= U_D - U_C \\ &= \frac{1}{4\pi\epsilon_0} \left(\frac{q_2 q_3}{0.1} - \frac{q_2 q_3}{0.5} \right) \end{aligned}$$

$$\text{but } \Delta U = \frac{q_3}{4\pi\epsilon_0} k$$

$$\therefore \frac{q_3}{4\pi\epsilon_0} k = \frac{1}{4\pi\epsilon_0} \left(\frac{q_2 q_3}{0.1} - \frac{q_2 q_3}{0.5} \right)$$

$$\Rightarrow k = q_2 (10 - 2) = 8q_2$$

27. In fission process, when a parent nucleus breaks into daughter products, then some mass is lost in the form of energy. Thus, mass of fission products < mass of parent nucleus

$$\Rightarrow \frac{\text{Mass of fission products}}{\text{Mass of parent nucleus}} < 1$$

NOTE : 1. Nuclear fission was discovered by Ottohan and Strassman.

2. In each fission reaction a tremendous amount of energy ($\approx 190 \text{ MeV}$) is released.

28. **Key Idea :** The heat converted to work is the amount of heat that remains after going through sink.

From the relation

$$\frac{Q_2}{Q_1} = \frac{T_2}{T_1}$$

Given,

$$Q_1 = 6 \times 10^4 \text{ cal,}$$

$$T_1 = 227 + 273 = 500 \text{ K}$$

$$T_2 = 127 + 273 = 400 \text{ K}$$

$$\therefore \frac{Q_2}{6 \times 10^4} = \frac{400}{500}$$

$$\Rightarrow Q_2 = \frac{4}{5} \times 6 \times 10^4$$

$$= 4.8 \times 10^4 \text{ cal}$$

Now, heat converted to work

$$= Q_1 - Q_2$$

$$= 6.0 \times 10^4 - 4.8 \times 10^4$$

$$= 1.2 \times 10^4 \text{ cal}$$

NOTE : Carnot cycle consists of following four stages :

- (i) Isothermal expansion
- (ii) Adiabatic expansion
- (iii) Isothermal compression
- (iv) Adiabatic compression

After doing the calculations for different processes, we achieve the relation

$$\frac{Q_2}{Q_1} = \frac{T_2}{T_1}$$

29. Key Idea : Two vectors must be perpendicular if their dot product is zero.

Let $\vec{a} = 2\hat{i} + 3\hat{j} + 8\hat{k}$

$\vec{b} = 4\hat{j} - 4\hat{i} + \alpha\hat{k}$

$= -4\hat{i} + 4\hat{j} + \alpha\hat{k}$

According to the above hypothesis :

$$\vec{a} \perp \vec{b}$$

$$\Rightarrow \vec{a} \cdot \vec{b} = 0$$

$$\Rightarrow (2\hat{i} + 3\hat{j} + 8\hat{k}) \cdot (-4\hat{i} + 4\hat{j} + \alpha\hat{k}) = 0$$

$$\Rightarrow -8 + 12 + 8\alpha = 0$$

$$\Rightarrow 8\alpha = -4$$

$$\therefore \alpha = -\frac{4}{8} = -\frac{1}{2}$$

NOTE : $\vec{a} \cdot \vec{b} = ab \cos \theta$. Here, a and b are always positive as they are the magnitudes of \vec{a} and \vec{b} .

30. Zener diode is a silicon crystal diode having an unusual reverse current characteristic which is particularly suitable for voltage regulating purposes. Due to this characteristic, it is used as voltage stabilizer in many applications in electronics.

Note : Transfer characteristic of zener diode is shown in the figure given below :

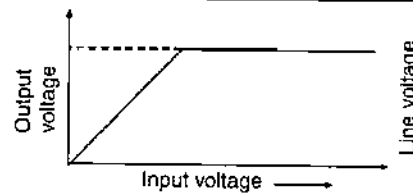

31. Key Idea : The work done will be the area of the $F-x$ graph.

Work done in moving the object from $x = 0$ to $x = 6 \text{ m}$ is given by

$$W = \text{area of rectangle} + \text{area of triangle}$$

$$= 3 \times 3 + \frac{1}{2} \times 3 \times 3$$

$$= 9 + 4.5 = 13.5 \text{ J}$$

32. Since, speed is constant throughout the motion, so it is a uniform circular motion. Therefore, its radial acceleration

$$a = r\omega^2$$

$$= r \left(\frac{2\pi n}{t} \right)^2 = r \times \frac{4\pi^2 n^2}{t^2}$$

$$= \frac{1 \times 4 \times \pi^2 \times (22)^2}{(44)^2}$$

$$= \pi^2 \text{ m/s}^2$$

This acceleration is directed along radius of circle.

NOTE : 1. In uniform circular motion $\frac{dv}{dt} = 0$.

Thus, $a_r = 0$ and $a = a_r = r\omega^2$.

2. In accelerated circular motion $\frac{dv}{dt}$ is positive i.e.,

\vec{a}_t is along \hat{e}_t or tangential acceleration of particle is parallel to velocity \vec{v} because $\vec{v} = r\omega\hat{e}_t$ and $\vec{a}_t = \frac{dv}{dt}\hat{e}_t$.

3. In decelerated circular motion $\frac{dv}{dt}$ is negative and hence, tangential acceleration is anti-parallel to velocity \vec{v} .

33. In diamagnetic substances in each pair of electrons, the spin of both the electrons are in opposite directions. Hence, the electrons of each pair completely cancel the magnetic moment of each other. Thus, the net magnetic moment of each atom of such substances is zero i.e., $\mu_d = 0$.

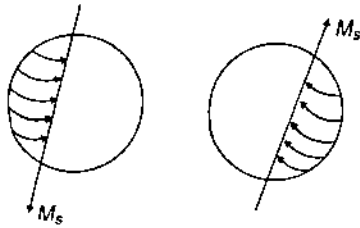

The property of paramagnetism is found in those substances whose atoms, or molecules have an excess of electrons spinning in same direction.

Hence, atoms of paramagnetic substances have permanent magnetic moment i.e., $\mu_p \neq 0$.

The property of ferromagnetism is found in substances which acquire very strong magnetism when placed in an external magnetic field. Like the paramagnetic substances each atom of ferromagnetic

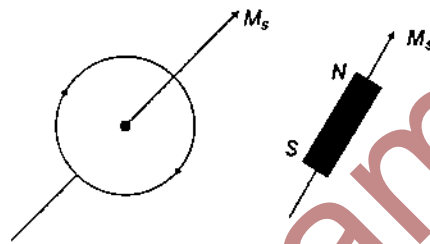

substances also has a permanent magnetic moment i.e., $\mu_f \neq 0$.

$$34. \quad \tan \phi = \frac{\omega L - \frac{1}{\omega C}}{R}$$

ϕ being the angle by which the current leads the voltage.

Given, $\phi = 45^\circ$

$$\therefore \tan 45^\circ = \frac{\omega L - \frac{1}{\omega C}}{R}$$

$$\Rightarrow 1 = \frac{\omega L - \frac{1}{\omega C}}{R}$$

$$\Rightarrow R = \omega L - \frac{1}{\omega C}$$

$$\Rightarrow \omega C = \frac{1}{(\omega L - R)}$$

$$\Rightarrow C = \frac{1}{\omega(\omega L - R)} = \frac{1}{2\pi f(2\pi fL - R)}$$

Note : In series resonance L-C-R circuit, $\frac{1}{\omega CR}$ is greater than unity.

$$35. \quad \text{Angular resolution} = \frac{1.22 \lambda}{d}$$

$$= \frac{1.22 \times 5000 \times 10^{-10}}{10 \times 10^{-2}}$$

$$= 6.1 \times 10^{-6}$$

$$\approx 10^{-6} \text{ rad}$$

36. Key Idea : To reach the solution the given wave equations must be compared with standard equation of progressive wave.

So,

$$y_1 = 4 \sin 500 \pi t. \quad \dots(i)$$

$$y_2 = 2 \sin 506 \pi t \quad \dots(ii)$$

Comparing Eqs. (i) and (ii) with

$$y = a \sin \omega t \quad \dots(iii)$$

We have,

$$\omega_1 = 500 \pi$$

$$\Rightarrow f_1 = \frac{500\pi}{2\pi} = 250 \text{ beats/s}$$

and $\omega_2 = 506 \pi$

$$\Rightarrow f_2 = \frac{506 \pi}{2\pi} = 253 \text{ beats/s}$$

Thus, number of beats produced

$$= f_2 - f_1 = 253 - 250$$

$$= 3 \text{ beats/s}$$

$$= 3 \times 60 \text{ beats/min}$$

$$= 180 \text{ beats/min}$$

37. When wire is bent to form a complete circle then

$$2\pi r = R$$

$$\Rightarrow r = \frac{R}{2\pi}$$

Resistance of each semicircle

$$= \pi r = \frac{\pi R}{2\pi} = \frac{R}{2}$$

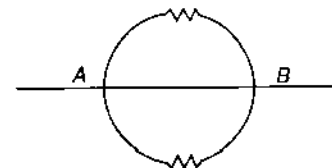

Thus, net resistance in parallel combination of two semicircular resistances

$$R' = \frac{\frac{R}{2} \times \frac{R}{2}}{\frac{R}{2} + \frac{R}{2}} = \frac{\frac{R^2}{4}}{R} = \frac{R}{4}$$

38. Carbon, silicon and germanium are semiconductors.

$$(E_g)_C = 5.2 \text{ eV}$$

$$(E_g)_{Si} = 1.21 \text{ eV}$$

$$(E_g)_{Ge} = 0.75 \text{ eV}$$

Thus, $(E_g)_C > (E_g)_{Si}$ and $(E_g)_C > (E_g)_{Ge}$

NOTE : Elements carbon, silicon and germanium are found in IVA group of periodic table.

39. Wavelength order of given rays are listed below :

Rays	Wavelength (Å)
Visible light	4000-7900
X-rays	1-100
Microwaves	$10^7 - 10^9$

Obviously,

$$\lambda_x < \lambda_v < \lambda_m$$

$$\text{or } \lambda_m > \lambda_v > \lambda_x$$

NOTE : Visible light, X-rays and microwaves are all electromagnetic waves.

40. Distance covered by boy A in time t

$$AC = vt \quad \dots(i)$$

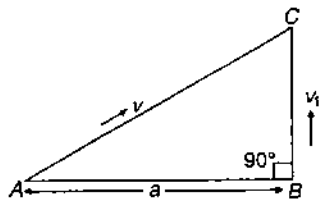

Distance covered by boy B in time t

$$BC = v_1 t \quad \dots(ii)$$

Using Pythagoras theorem

$$AC^2 = AB^2 + BC^2$$

$$\text{or } (vt)^2 = a^2 + (v_1 t)^2$$

$$\text{or } v^2 t^2 - v_1^2 t^2 = a^2$$

$$\text{or } t^2 (v^2 - v_1^2) = a^2$$

$$\therefore t = \sqrt{\frac{a^2}{v^2 - v_1^2}}$$

41. Power $P = i^2 R$

$$\Rightarrow R = \frac{P}{i^2}$$

$$\text{Given, } P = 1 \text{ W, } i = 5 \text{ A}$$

$$\therefore R = \frac{1}{(5)^2} = 0.04 \Omega$$

42. As said, $(KE)_{\text{rot}}$ remains same.

$$\text{i.e., } \frac{1}{2} I_1 \omega_1^2 = \frac{1}{2} I_2 \omega_2^2$$

$$\Rightarrow \frac{1}{2I_1} (I_1 \omega_1)^2 = \frac{1}{2I_2} (I_2 \omega_2)^2$$

$$\Rightarrow \frac{L_1^2}{I_1} = \frac{L_2^2}{I_2}$$

$$\Rightarrow \frac{L_1}{L_2} = \sqrt{\frac{I_1}{I_2}}$$

$$\text{but } I_1 = I, I_2 = 2I$$

$$\therefore \frac{L_1}{L_2} = \sqrt{\frac{I}{2I}} = \frac{1}{\sqrt{2}}$$

$$\text{or } L_1 : L_2 = 1 : \sqrt{2}$$

43. The time period of electron moving in a circular orbit

$$T = \frac{\text{circumference of circular path}}{\text{speed}}$$

$$= \frac{2\pi r}{v}$$

and equivalent current due to electron flow

$$I = \frac{e}{T} = \frac{e}{(2\pi r/v)} = \frac{ev}{2\pi r}$$

Magnetic field at centre of circle

$$B = \frac{\mu_0 I}{2r} = \frac{\mu_0 ev}{4\pi r^2}$$

$$\Rightarrow r \propto \sqrt{\frac{v}{B}}$$

44. (a) In insulators energy gap is of the order of 5 to 10 eV and it is practically impossible to impart this much amount of energy to the electrons in valence band.

So as to jump to conduction band.

So, choice (a) is correct.

(b) In semiconductors with the rise in temperature more electrons from valence band jump to conduction band and this results in increase in conductivity. So, choice (b) is correct.

(c) In conductors, the conduction band is either partially filled or the conduction band overlaps on the valence band. So, choice (c) is correct.

(d) In semiconductor, resistivity, decreases with increase in temperature.
So, choice (d) is wrong.

45. $(\vec{B} \times \vec{A}) \cdot \vec{A}$

$$= B A \cos \theta \hat{n} \cdot \vec{A}$$

$$= 0$$

Here \hat{n} is perpendicular to both \vec{A} and \vec{B} .

Alternative : $(\vec{B} \times \vec{A}) \cdot \vec{A}$

Interchange the cross and dot, we have,

$$(\vec{B} \times \vec{A}) \cdot \vec{A} = \vec{B} \cdot (\vec{A} \times \vec{A}) = 0 \quad (\because \vec{A} \times \vec{A} = 0)$$

NOTE : The volume of a parallelepiped bounded by vectors \vec{A} , \vec{B} and \vec{C} can be obtained by giving formula $(\vec{A} \times \vec{B}) \cdot \vec{C}$.

46. **Key Idea :** We should use parallel axis theorem.

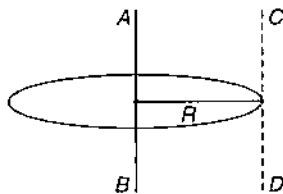

Moment of inertia of disc passing through its centre of gravity and perpendicular to its plane is

$$I_{AB} = \frac{1}{2} MR^2$$

Using theorem of parallel axes, we have,

$$I_{CD} = I_{AB} + MR^2$$

$$= \frac{1}{2} MR^2 + MR^2$$

$$= \frac{3}{2} MR^2$$

NOTE : The role of moment of inertia in the study of rotational motion is analogous to that of mass in study of linear motion.

47. Interatomic spacing for a fcc lattice

$$r = \left[\left(\frac{a}{2} \right)^2 + \left(\frac{a}{2} \right)^2 + (0)^2 \right]^{1/2} = \frac{a}{\sqrt{2}}$$

a being lattice constant.

$$\therefore a = \sqrt{2}r = \sqrt{2} \times 2.54 = 3.59 \text{ \AA}$$

NOTE : Interatomic spacing is just the nearest neighbours distance.

48. **Key Idea :** The kinetic energy is equal to the negative of total energy.

Kinetic energy of electron

$$K = \frac{Ze^2}{8\pi\epsilon_0 r}$$

Potential energy of electron

$$U = -\frac{1}{4\pi\epsilon_0} \frac{Ze^2}{r}$$

\therefore Total energy

$$E = K + U = \frac{Ze^2}{8\pi\epsilon_0 r} - \frac{Ze^2}{4\pi\epsilon_0 r}$$

or $E = -\frac{Ze^2}{8\pi\epsilon_0 r}$

or $E = -K$

or $K = -E = -(-3.4) = 3.4 \text{ eV}$

49. **Key Idea :** The potential energy of satellite is twice its kinetic energy but opposite in sign.

Potential energy,

$$U = -\frac{GM_e m}{R_e} \text{ or } |U| = \frac{GM_e m}{R_e}$$

Kinetic energy,

$$K = \frac{1}{2} \frac{GM_e m}{R_e}$$

Thus, $\frac{K}{|U|} = \frac{1}{2} \frac{GM_e m}{R_e} \times \frac{R_e}{GM_e m} = \frac{1}{2}$

NOTE : The total energy $E = K + U = -\frac{GM_e m}{2r}$

This energy is constant and negative, i.e., the

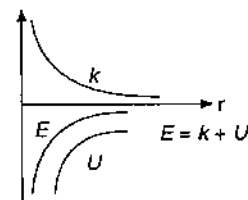

system is closed. The farther the satellite from the earth the greater its total energy.

50. **Key Idea :** The problem can be solved using third equation of motion at A and O'.

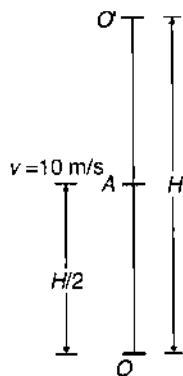

Let maximum height attained by the ball be H .
Third equation of motion gives

$$v^2 = u^2 - 2gh$$

$$\text{At A, } (10)^2 = u^2 - 2 \times 10 \times \frac{H}{2}$$

$$\Rightarrow u^2 = 100 + 10H \quad \dots(i)$$

$$\text{At O', } (0)^2 = u^2 - 2 \times 10 \times H$$

$$\Rightarrow u^2 = 20H \quad \dots(ii)$$

Thus, from Eqs. (i) and (ii), we get

$$20H = 100 + 10H$$

$$\Rightarrow 10H = 100 \therefore H = 10 \text{ m}$$

Chemistry

51. The most stable carbocation is *t*-alkyl carbocation because the order of stability of alkyl carbocation is *t*-alkyl > *s*-alkyl > *p*-alkyl > CH_3^+ carbocation. This stability order is described with the help of hyperconjugation and inductive effect. On the basis of hyperconjugation, $(\text{CH}_3)_2\text{CH}^+$ shows six resonating structures due to presence of six α C—H bonds,

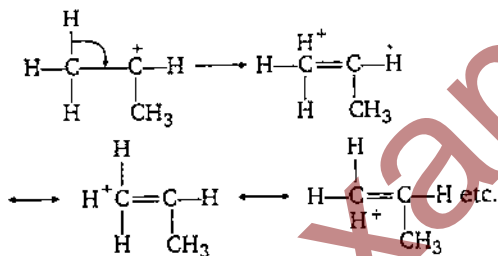

due to presence of nine α C—H bonds.

C H_3 does not show the property of resonance while $\text{CH}_3-\text{CH}_2^+$ shows three resonating structures due to presence of three

α C—H bonds. Hence, larger number of resonating structures are possible in (2), so it is most stable. The above order of stability is also explained with the help of (+) *I*-effect of $-\text{CH}_3$ group. More the number of $-\text{CH}_3$ group more will be tendency to displace the electrons towards positive charged carbon of carbocation. Thus (+) charge is decreased or compensated i.e., positive charge is decreased and stability of carbocation is increased.

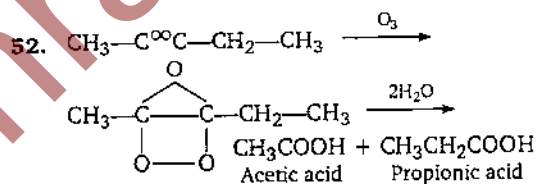

53. Base BOH is dissociated as follows

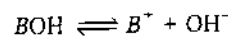

So, the dissociation constant of BOH base

$$K_b = \frac{[\text{B}^+][\text{OH}^-]}{[\text{BOH}]} \quad \dots(i)$$

At equilibrium $[\text{B}^+] = [\text{OH}^-]$

$$\therefore K_b = \frac{[\text{OH}^-]^2}{[\text{BOH}]}$$

Given that $K_b = 1.0 \times 10^{-12}$ and

$$[\text{BOH}] = 0.01 \text{ M}$$

Thus $1.0 \times 10^{-12} = \frac{[\text{OH}^-]^2}{0.01}$

$$[\text{OH}^-]^2 = 1 \times 10^{-14}$$

$$[\text{OH}^-] = 1.0 \times 10^{-7} \text{ mol L}^{-1}$$

54. Pair of optical isomerism and geometrical isomerism are able to exhibit the phenomenon of stereoisomerism because both type of isomers differ only in their orientation in space.

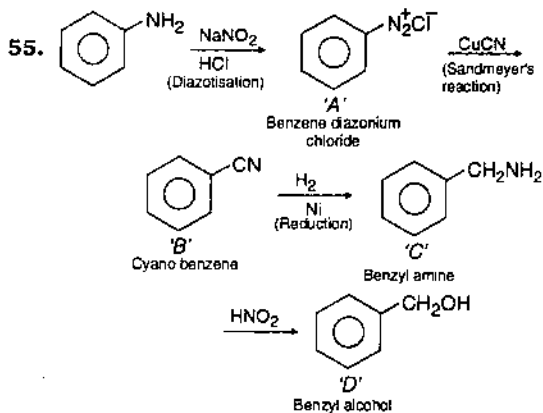

56. Bond length of O—O in $\text{O}_2 = 1.21 \text{ \AA}$
 Bond length of O—O in $\text{O}_3 = 1.278 \text{ \AA}$
 Bond length of O—O in $\text{H}_2\text{O}_2 = 1.49 \text{ \AA}$
 Therefore, correct order of O—O bonds length is : (bond order decrease in the same order)

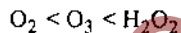

57. In Hall and Heroult process

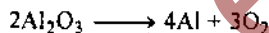

Only for removal of CO_2 , following equation is possible

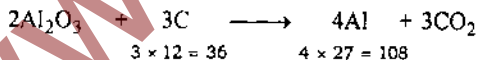

\therefore For 108 g of Al, 36 g of C is required in above reaction

\therefore For 270 g of Al require amount of C

$$= \frac{36}{108} \times 270 = 90\text{g}$$

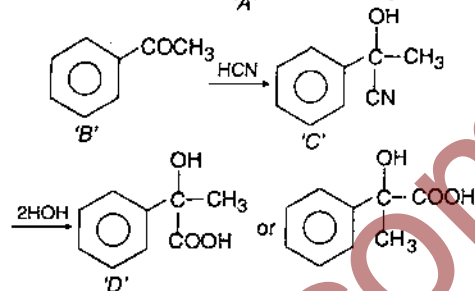
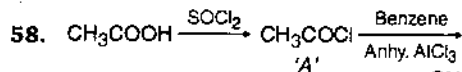

59. The cell membranes are mainly composed of phospholipids.

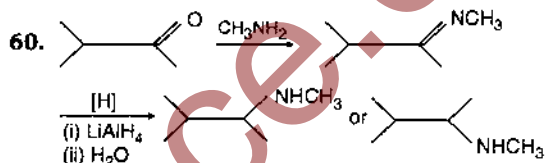

61. In alkaline solution, KMnO_4 is reduced to MnO_2 (colourless).

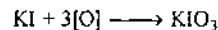
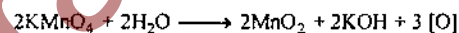

Hence, two moles of KMnO_4 are reduced by one mole of KI.

62. IF_3 has bent-T geometry

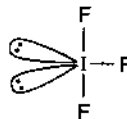

PCl_3 has pyramidal geometry

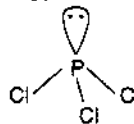

NH_3 has pyramidal geometry

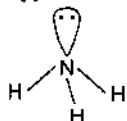

BF_3 has trigonal planar geometry

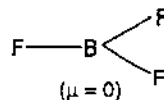

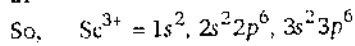
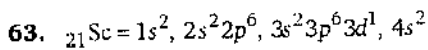

(It is colourless due to absence of unpaired electrons in d -subshell)

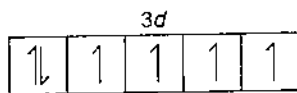
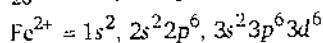
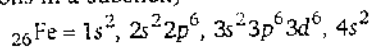

(It is coloured due to presence of four unpaired electrons in d -subshell)

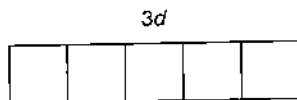
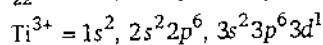
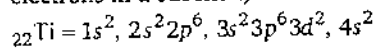

(It is coloured due to presence of an unpaired electron in d -subshell)

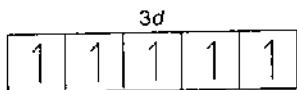
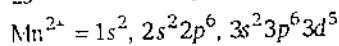
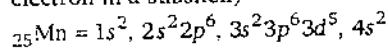

(It is coloured due to presence of unpaired electrons in d -subshell)

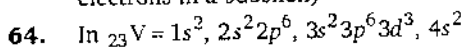

Third electron which is removed in third ionisation potential enthalpy belongs to $3d^3$ sub-shell.

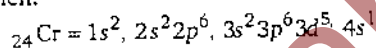

Third electron which is removed in third ionisation potential enthalpy belongs to $3d^5$ sub-shell.

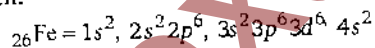

Third electron which is removed in third ionisation potential enthalpy belongs to $3d^6$ sub-shell.

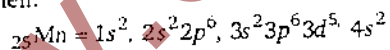

Third electron which is removed in third ionisation potential belongs to $3d^5$ sub-shell.

In all elements shell and sub-shells are same. Required amount of energy (enthalpy) is based upon the stability of d -subshell.

The $3d^5$ sub-shell has highest stability in all because it is half filled sub-shell (while other are incomplete). So Mn shows highest third ionisation potential or enthalpy.

65. Phenols are much more acidic than alcohols, due to the stabilisation of phenoxide ion by resonance.

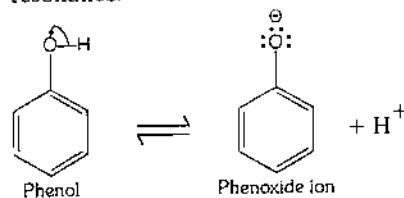

Phenoxide ion is stabilized due to following resonating structures :

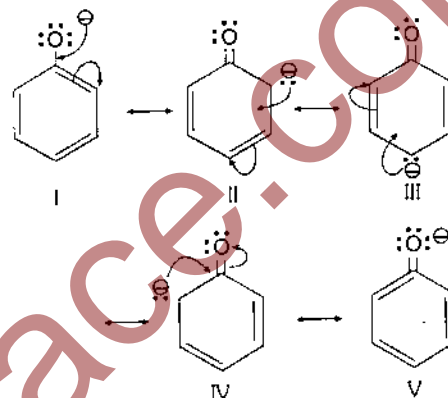

While in alcohols

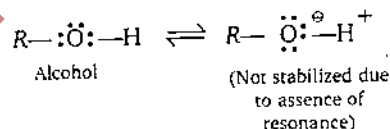

Ortho nitrophenol is most acidic because in it $-\text{NO}_2$ electron attracting group is attached on *ortho* position which helps in stabilizing of negative charge on the oxygen of phenoxide ion. Hence, due to this reason acidic character of phenol is increased, while on attachment of $-\text{CH}_3$ group (electron donating group) acidic strength of phenol is decreased in cresol due to destabilization of phenoxide ion.

66. The spontaneity of reaction is based upon the negative value of ΔG , ΔG is based upon T , ΔS and ΔH according to following equation (Gibbs-Helmholtz equation)

$$\Delta G = \Delta H - T\Delta S$$

If the magnitude of $\Delta H - T\Delta S$ is negative, then the reaction is spontaneous.

when $T\Delta S > \Delta H$ and ΔH and ΔS are +ve, then ΔG is negative.

67. The monomer of polymer

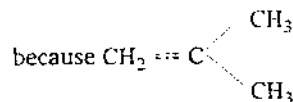
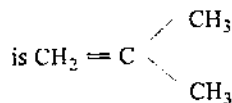
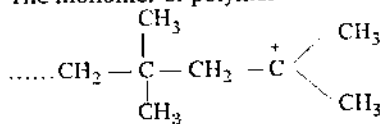

shows cationic polymerisation.

68. On the basis of Fajan's rule, lower the size of cation higher will be its polarising power and higher will be covalent character.

$$\therefore \text{Polarising power} \propto \frac{1}{\text{size of cation}}$$

Covalent character \propto Polarising power
So the correct order is

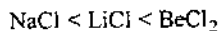

(The order of size of cation $\text{Na}^+ > \text{Li}^+ > \text{Be}^{2+}$)

69. The correct order of pH of isomolar solution in sodium oxide (pH_1), sodium sulphide (pH_2), sodium selenide (pH_3) and sodium telluride (pH_4) is $\text{pH}_1 > \text{pH}_2 > \text{pH}_3 > \text{pH}_4$ because in aqueous solution, they are hydrolysed as follows.

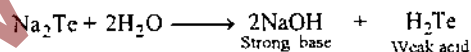
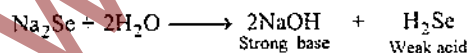
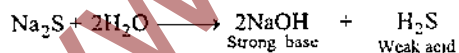
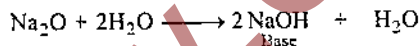

Order of acidic strength

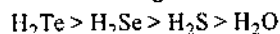

Order of neutralisation of NaOH

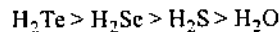

Hence, their aqueous solutions have the following order of basic character due to neutralisation of NaOH with H_2O , H_2S , H_2Se and H_2Te

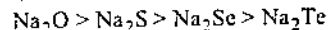

(\therefore pH of basic solution is higher than acidic or least basic solution)

70. If reaction is exothermic, therefore, ΔH is -ve and on increasing disorder, ΔS is +ve thus, at these condition, ΔG is negative according to following equation.

$$\Delta G = \Delta H - T\Delta S$$

$\Delta G =$ -ve. Hence, for spontaneous reaction ΔG must be -ve.

71. Mole fraction of P = $\frac{3}{3+2} = \frac{3}{5}$

$$\text{Mole fraction of Q} = \frac{2}{3+2} = \frac{2}{5}$$

Hence, total vapour pressure

= Mole fraction of P \times V.P. of P + mole fraction of Q \times V.P. of Q

$$= \left(\frac{3}{5} \times 80 + \frac{2}{5} \times 60 \right) = 48 + 24$$

$$= 72 \text{ Torr}$$

72. Stability of alkene

$$\propto \frac{1}{\text{Heat of hydrogenation of alkene}}$$

Greater the number of alkyl groups attached to the doubly bonded carbon atoms, more stable is the alkene. Hence, given alkene follow the following order of stability.

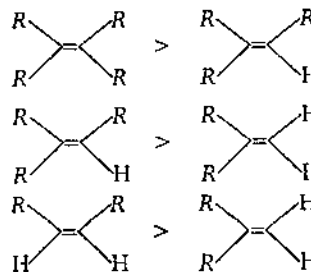

Hence, faster hydrogenation in

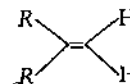

73. For first order reaction



Given that rate = $k \times [\text{A}]$

$$\text{Rate} = 2.0 \times 10^{-5} \text{ mol L}^{-1} \text{ s}^{-1}$$

[A] = Conc. of A = 0.01 M

So $2.0 \times 10^{-5} = k \times 0.01$

$$k = \frac{2.0 \times 10^{-5}}{0.01} \text{ s}^{-1}$$

$$= 2.0 \times 10^{-3} \text{ s}^{-1}$$

For first order reaction

$$T_{1/2} = \frac{0.693}{k} = \frac{0.693}{2.0 \times 10^{-3}}$$

$$= 346.5 \approx 347 \text{ s}$$

74. B_2H_6 is electron deficient molecule because boron atom has three half filled orbitals in excited state. The structure of B_2H_6 is represented as follows :

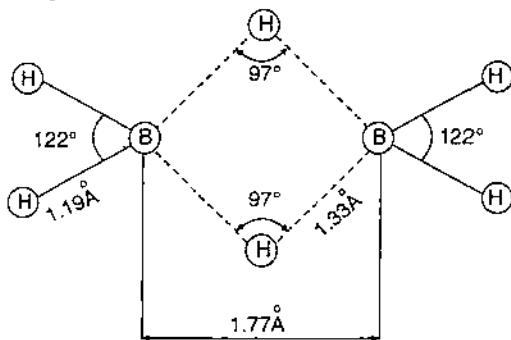

In it two electrons of a B—H bond are involved in formation of three centre bond, these bonds are represented as dotted lines.

75. After decay of radioactive element, the last element (stable) Pb is obtained which belongs to group 14 of periodic table.
76. Surface tension of H_2O is maximum due to maximum hydrogen bonding in comparison to C_6H_6 , CH_3OH , C_2H_5OH . The order of H-bonding is
- $$H_2O > CH_3OH > C_2H_5OH$$
- (Benzene does not form H-bond).
77. Heat of neutralization of strong acid and strong base is -57.33 kJ . MgO is weak base while HCl is strong acid, so the heat of neutralization of MgO and HCl is lower to -57.33 kJ because MgO requires some heat in ionisation, then net released amount of heat is decreased.
78. Surfactants detergents form micelles in aqueous solution above to their C.M.C (critical micelle concentration). Dodecyl trimethyl ammonium chloride is an example of surfactant (cationic surfactant), so it shows a following phenomena.

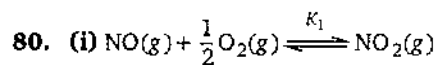
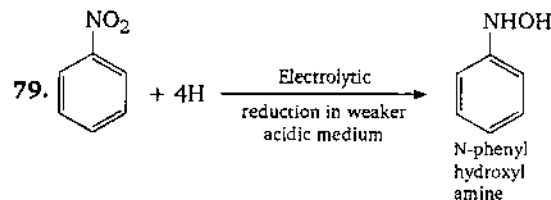
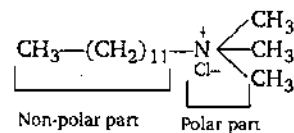

So $K_1 = \frac{[NO_2]}{[NO][O_2]^{1/2}} \dots (i)$

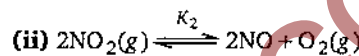

So $K_2 = \frac{[NO]^2[O_2]}{[NO_2]^2} \dots (ii)$

From Eq. (i)

$$K_1^2 = \frac{[NO_2]^2}{[NO]^2[O_2]}$$

or $\frac{1}{K_1^2} = \frac{[NO]^2[O_2]}{[NO_2]^2} \dots (iii)$

From Eqs. (ii) and (iii)

$$K_2 = \frac{1}{K_1^2}$$

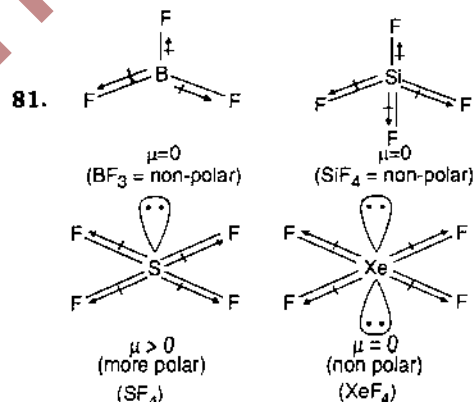

82. Aliphatic S_N1 reaction is carried out in two steps. In form of slow step Step (i) carbonium (carbocation) ion is formed and its formation is based upon the stability Stability order of carbocation

$C_6H_5\overset{+}{C}H_2 > CH_3-\overset{+}{C}H-CH_3 > CH_3-\overset{+}{C}H_2$
 and in step (ii) nucleophile is attracted towards the carbonium ion in form of fast step to give final product.

Hence, in benzyl chloride, ethyl chloride and isopropyl chloride order of S_N1 reaction is benzyl chloride > isopropyl chloride > ethyl chloride

In chlorobenzene, mechanism of S_N1 reaction is differ to aliphatic alkyl halide. The aryl halides are much less reactive as compared to alkyl halides, towards nucleophilic reagents in either S_N1 or S_N2 reaction.

The carbon-halogen bond in the aryl halide is quite strong and only forcing conditions can break up this bond.

Hence,

Step (i)

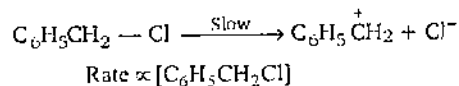

Step (ii)

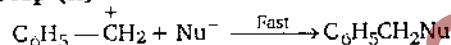

83. $A + B \longrightarrow \text{Product}$

$$\text{Rate} \propto [A][B]^{-2} \quad \dots (i)$$

The rate decreases by factor 4 if the concentration of reactant 'B' is doubled

So $\text{Rate} \propto [A][2B]^{-2}$

$$\propto \frac{[A][B]^{-2}}{4} \quad \dots (ii)$$

Hence, order of reaction w.r.t. reactant B is -2.

84. In a face centered cubic lattice a unit cell is shared equally by six unit cells.

85. $\therefore \Delta T_f = k_f \times \text{Molality of solution}$

$$\Delta T_b = k_b \times \text{Molality of solution}$$

or $\frac{\Delta T_f}{\Delta T_b} = \frac{k_f}{k_b}$

Given that

$$\Delta T_b = T_2 - T_1 = 100.18 - 100 = 0.18$$

$$k_f \text{ for water} = 1.86K \text{ kg mol}^{-1}$$

$$k_b \text{ for water} = 0.512K \text{ kg mol}^{-1}$$

$$\therefore \frac{\Delta T_f}{0.18} = \frac{1.86}{0.512}$$

$$\Delta T_f = \frac{1.86 \times 0.18}{0.512}$$

$$= 0.6539 \sim 0.654$$

$$\Delta T_f = T_1 - T_2$$

$$0.654 = 0^\circ C - T_2$$

$$\therefore T_2 = -0.654^\circ C$$

($T_2 \rightarrow$ Freezing point of aqueous urea solution)

86. Disulphide bond may be reduced to thiol by means of reagents i.e., $NaBH_4$, which shows the presence of thiol group in disulphide bond formation.

87. In $[Co(NH_3)_6]^{3+}$, oxidation state of Co = +3 and its co-ordination number is six.

$$\text{So } {}_{27}Co = 1s^2, 2s^2, 2p^6, 3s^2, 3p^6, 3d^7, 4s^2$$

$$Co^{3+} = 1s^2, 2s^2, 2p^6, 3s^2, 3p^6, 3d^6$$

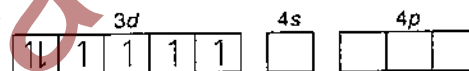

In complex ion

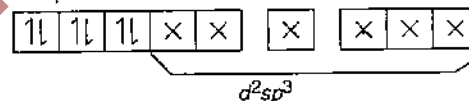

In $[Co(NH_3)_6]^{3+}$ shows inner orbital complex as well as diamagnetic in behaviour (due to absence of unpaired electron).

$[Zn(NH_3)_6]^{2+} \rightarrow sp^3d^2$ hybridisation (outer) and diamagnetic.

$[Cr(NH_3)_6]^{3+} \rightarrow d^2sp^3$ hybridisation (inner) and paramagnetic.

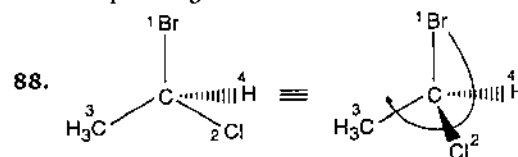

Lowest priority atom is always away from the viewer. Priority is seen on the basis of atomic number and if atomic numbers are same then on the basis of second or third bond in above figure priority order group or atom is $-Br > -Cl > -CH_3 > H$ and in it rotation is clockwise. So it shows R-configuration.

89. In qualitative analysis of cation of second group H₂S gas is passed in presence of HCl,

of sulphide ions is obtained which is sufficient for the precipitation of second group cations in form of their sulphides due to lower value of their solubility product (K_{sp}). Here, fourth group cations are not precipitated because they require for exceeding their ionic product to their solubility products and higher sulphide ions concentration due to their higher K_{sp} which is not obtained here due to common ion effect.

90. ClO_2 shows paramagnetic character due to presence of unpaired electron in its structure.

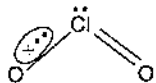

91. *Trans* $[\text{Co}(\text{en})_2 \text{Cl}_2]$ is able to exhibit the phenomena of optical isomerism because it can form a superimposable mirror image.

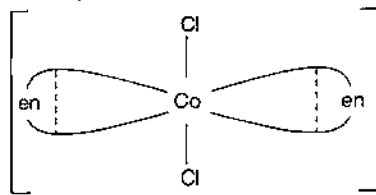

92. The energy of second Bohr orbit of hydrogen atom (E_2) is -328 kJ mol^{-1} because

$$E_2 = -\frac{1312}{2^2} \text{ kJ mol}^{-1}$$

$$\therefore E_n = -\frac{1312}{n^2} \text{ kJ mol}^{-1}$$

If $n = 4$

$$\therefore E_4 = -\frac{1312}{4^2} \text{ kJ mol}^{-1} = -82 \text{ kJ mol}^{-1}$$

93. Correct order of acid strength

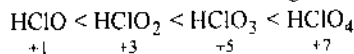

Acid strength \propto oxidation number.

94. The main reason for larger number of oxidation states exhibited by actinides than corresponding lanthanides is lesser energy difference between $5f$ and $6d$ orbitals than between $4f$ and $5d$ -orbitals.

- 95.

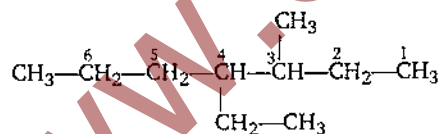

Correct IUPAC name is 4-ethyl-3-methylheptane because substituents are written in alphabetical order.

96. The correct order of electron gain enthalpy (electron affinity) is $\text{O} < \text{S} < \text{F} < \text{Cl}$
(electron affinity $\text{O} < \text{S} < \text{F} < \text{Cl}$
in eV) 1.48 2.07 3.45 3.61

97. Total vapour pressure of mixture
= (Mole fraction of pentane \times V.P. of pentane) +
(Mole fraction of hexane \times V.P. of hexane)
= V.P. of pentane in mixture + V.P. of hexane
in mixture

$$= \left(\frac{1}{5} \times 440 + \frac{4}{5} \times 120 \right) = 184 \text{ mm}$$

\therefore V.P. of pentane in mixture

= V.P. of mixture \times mole fraction of pentane in vapour phase

$88 = 184 \times$ mole fraction of pentane in vapour phase

\therefore Mole fraction of pentane in vapour phase

$$= \frac{88}{184} = 0.478$$

98. From second law of Faraday

$$\frac{m_{\text{Al}}}{m_{\text{H}}} = \frac{E_{\text{Al}}}{E_{\text{H}}}$$

$$\therefore \frac{4.5}{m_{\text{H}}} = \frac{27/3}{1}$$

or $m_{\text{H}} = 0.5 \text{ g}$

$\therefore 2 \text{ g H}_2$ volume at STP = 22.4 L

$\therefore 0.5 \text{ g H}_2$ volume at STP

$$= \frac{22.4 \times 0.5}{2} \text{ L} = 5.6 \text{ l.}$$

99. The best method for the separation of naphthalene and benzoic acid from their mixture is sublimation because it is applicable for those organic compounds which pass directly from solid to vapour state on heating and *vice-versa* on cooling. In these compounds naphthalene is volatile and benzoic acid is non-volatile due to the formation of dimer *Via* hydrogen bonding (intermolecular).

100. Molality of solution = Mole of solute per kg of solvent

So 1 m = 1 mole of solute per 1000 g of solvent

Hence, moles of solute in 1 m aqueous solution = 1

moles of solvent in 1 m aqueous solution

$$= \frac{1000}{18} = 55.55$$

Mole fraction of solute in 1 m solution

$$= \frac{1}{1 + 55.55} = \frac{1}{56.55} = 0.0176 \approx 0.018$$

101. Porter coined the name Endoplasmic Reticulum (ER). It is a network of tubules, vesicles and cisternae within an eukaryotic cell (absent in prokaryotic cells). Two types of ER are recognised on the basis of presence/absence of ribosomes on the wall of the ER.

- (i) **Smooth ER**—Wall of this ER does not have ribosomes. Smooth ER helps in the synthesis of lipid and glycogen.
- (ii) **Rough ER**—Wall of this ER contains ribosomes. Rough ER is involved in protein synthesis and transfer.

Protein synthesis takes place in ribosomes attached on wall of ER. Newly formed protein enters within the cavity of rough ER and follows following path :

Protein → cavity of rough ER → cavity of smooth ER → Golgi membrane → lysosomes or transport vesicles or secretory granules.

102. There are two models about origin of Modern man (*Homo sapiens sapiens*) i. e.,

- (i) **Multiregional model** : According to this view, Modern humans evolved in many parts of the world from regional descendants of *Homo erectus* who dispersed from Africa between 1 and 2 million years ago.
- (ii) **Monogenesis model** : According to this view only African descendants of *Homo erectus* gave rise to Modern humans. In late 1980s Rebecca Cann and other geneticists supported this view on the basis of DNA of living humans. They compared the mitochondrial DNA (*mt*-DNA) of a multiethnic sample of more than 100 people representing four continents. The greater the difference between the *mt*-DNAs of two peoples, the longer ago that *mt*-DNAs diverged from a common source. By using bioinformatics, they concluded that the divergence of *mt*-DNA of Africans from common source began just 200,000 years ago, much too late to represent the dispersal of *Homo erectus*. Thus there are greater variation in Asia than in Africa.

103. The world's highly prized wool yielding 'Pashmina' breed is goat.

104. The grey crescent area is the area of just opposite to the entry of sperm into ovum.

105. The fixation of CO₂ in C₄ plants takes place in two places and by two different organic compounds. Phosphoenol pyruvate (PEP) is found in mesophyll cells which primarily fix atmospheric CO₂ into oxaloacetic acid (4C). RUBISCO is present in bundle sheath cells where final fixation of CO₂ in hexose sugars takes place. CO₂ is primarily fixed by PEP carboxylase because this enzyme has greater affinity to CO₂ than RUBISCO.

106. Histone proteins are basic proteins and are used in packing of eukaryotic (absent in prokaryotes) DNA. DNA and histones together comprise chromatin, forming bulk of the eukaryotic chromosomes. Histones are of five major kinds H₁, H_{2A}, H_{2B}, H₃ and H₄. H₁ histones link neighbouring nucleosomes (fundamental packing units of an eukaryotic chromosome), while other are elements of nucleosome structure. During S-phase of cell cycle synthesis of histone proteins take place because at this stage number of chromosomes become double to that of somatic number.

107. Lichen is a symbiotic association between a fungus and an algae (green alga or blue green alga). The algal partner of lichen is called as phycobiont while fungal partner is termed as mycobiont. Lichen develops into a unique morphological form which is quite distinct from either partner. The fungal partner of lichen helps in the absorption of water and mineral to algal partner additionally it also provides protection and anchorage to algal partner of lichen. In exchange of this, the fungal partner absorbs prepared food material from algal partner. This food material is prepared by the algal partner of lichen through the process of photosynthesis.

108. Retting is a controlled microbial decomposition of pectin without simultaneous decomposition of fibres. Retting process is

used for obtaining fibres from stems of flax, hemp, jute etc. For this purpose stems of fibre yielding plants are immersed in water for long period where decomposition sets in. Retting is facilitated by anaerobic butyric acid bacteria such as *Clostridium botulinum*, *Clostridium tetani* and *Clostridium perfringens*. These bacteria primarily decompose the plant pectin thus freeing the fibres. If process of retting continues for a long time then cellulose fermenting bacteria develop and destroy the fibres.

109. Resolving power or resolution is the ability of the lens to distinguish fine details and structure. Specifically it refers to the ability of the lenses to distinguish between two points at a specified distance apart. Resolving power depends on two factors :

- (i) Wavelength of light used for illumination.
- (ii) Power of objective lenses.

$$\text{Resolving power} = \frac{\text{wavelength of light}}{2 \times \text{NA}}$$

Since the limit of resolving power of a microscope is fixed by the structure of light, the shortest wavelength of visible light will give the maximum resolution. Among yellow, green, red and blue light colour. Blue (500 nm) have shortest wavelength so, it will give best resolution.

110. Kidneys help in the formation of urine, from the blood flowing through glomerular capillaries. About 20% of plasma fluid filters out into the Bowman's capsule through a thin glomerular-capsular membrane due to a net or effective filtration of about 10 to 15 mm Hg. So, the nearest option is (a).
111. At 40° North and South the heat gain through insolation approximately equal to the heat loss through terrestrial radiation.
112. A genetic characteristic that is determined by genes located on the sex chromosomes (X or Y) are called sex linked characteristic and the condition where expression of sex linked genes is limited to one sex is called sex limited characteristics. In given problem, disease is the result of sex-linked recessive genes. As neither man nor woman shows signs of disease it means woman would be carrier for disease causing gene. In their children none of the daughter is suffering from disease, while the

sons are suffering, it means daughters are also carrier (i. e., X-linked recessive).

Suppose, genotype of man = X Y
Genotype of woman = X^d X
(d-disease causing gene)

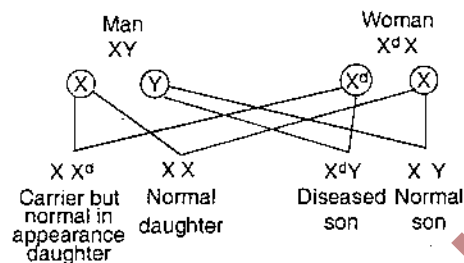

For each delivery the probability for each combination is 25%. So, among seven children 2 normal daughter, 3 diseased sons and 2 normal sons are possible.

113. Mammals are ureotelic organisms. In these organisms the ammonia deposited in the mitochondria of liver cells is converted into urea in the Ornithine cycle or urea cycle. Hans Krebs discovered this cycle in 1932 (who later also discovered citric acid cycle). Urea production is occurred almost exclusively in liver and it passes into blood stream and then to kidneys. During excretion of this urea through kidneys, CO₂ is also excreted.
114. Ends of an eukaryotic chromosome are known as telomeres. These are very necessary for integrity of chromosomes. Telomeres are characterized by repeated DNA sequences (2-10 bp long). This feature is common to all chromosomes of a species and is conserved. Telomerase, which is a special ribonucleoprotein molecule (enzymatic in nature) is responsible for the synthesis of these telomeres.
115. TATA box is present in eukaryotic promoter region. It has a resemblance with pribnow box of prokaryotes. TATA box was identified by Dr. Hogness and so, it is also called as Hogness box. It is a 7 bp long region located 20 bp upstream to the start point. During the process of transcription the RNA polymerase (a holoenzyme which has a core unit and a sigma factor for proper initiation of transcription) binds to TATA box due to which DNA assumes a saddle like structure at this place.

116. Chromosomes are responsible for the transmission of the hereditary information from one generation to the next. The arms of chromosome is known as chromatids. These arms are held together at a point called the centromere (or primary constriction). Centromere occurs any where along the length of chromosome. During cell division spindle fibres are attached to centromere and help in the movement of chromosomes towards the poles.
117. Thymus gland is found in the upper part of thorax near the heart. It is a bilobed pinkish gland. At the time of birth, it is a prominent gland but in the adult it gradually atrophies. This gland secretes thymosin hormone, thymic humoral factor, thymic factor and thymopoietin. Proliferation of lymphocytes and differentiation of these lymphocytes into a variety of clones are induced by these factors. These clones are differentially specialized to destroy different specific category of antigens and pathogens. Thus thymus gland brings fourth T-lymphocytes for cell mediated immunity.
118. Prolonged liberal irrigation of agricultural fields creates the problem of salinity.
119. Chloroplast, which is a cytoplasmic cell organelle finds only in eukaryotic plant cells. These structures help in the manufacture of food through, photosynthesis. Chlorophyll is a specialized light absorbing pigment which is found in the inner wall of granum. Each granum is a flat, sac like structure in which light reaction of photosynthesis takes place.
120. Wheat, rice and maize belongs to family Poaceae or Graminae. The main fruit type of these crops is caryopsis in which fruit wall is fused with seed coat. These crops are cultivated in all over the world and are contributed maximum to global food grain production.
121. Mitochondria are the eukaryotic cell organelles (do not present in prokaryotic cells). These originate from pre-existing mitochondria only. Mitochondria are also known as semi autonomous organelles because they contain a circular, double stranded DNA molecule, RNA and 70 S type of ribosomes. The genes located outside of

nucleus (*i.e.*, within the cytoplasm) also governs some traits, are referred to as plasmogenes or cytoplasmic genes. Cytoplasmic male sterility (*i.e.*, dominance of female cytoplasmic genes over male) is due to plasmogenes located in mitochondrial DNA (*mt-DNA*).

122. DNAase (or deoxyribonuclease) or simply nuclease is an enzyme which breaks down DNA by hydrolysis of the phosphodiester bonds of its sugar-phosphate back bone. Depending on the position of hydrolysing phosphodiester bonds, nucleases are of two types :
- (i) Endonucleases (ii) Exonucleases.
- Endonucleases hydrolyse internal phosphodiester bonds in a polynucleotide chain (*i.e.*, DNA). While exonucleases hydrolyse terminal phosphodiester bonds in a polynucleotide chain (*i.e.*, DNA).
123.

	Column-I	Column-II
A.	Peritrichous flagella (flagella all over the body)	— <i>Escherichia coli</i> (a bacterium)
B.	Living fossil	— <i>Ginkgo biloba</i> (maidan hair tree)
C.	Rhizophore (a form of aerial adventitious roots)	— <i>Selaginella</i> (a pteridophyte)
D.	Smallest flowering plant	— <i>Wolffia</i>
E.	Largest perennial algae	— <i>Macrocystes</i>
124. Norman Borlaug is associated with green revolution. The green revolution means an increase in the production of crops particularly cereal crops. Such as wheat, rice and maize.
125. G - 6 - P dehydrogenase deficiency is associated with haemolysis of RBCs.
126. Marginal notches in *Kalanchoe* and *Bryophyllum* possess adventitious buds in their leaves for vegetative propagation.
127. Approximately 300 species and sub species of mammals are considered as endangered by the International Union for the Conservation of Nature and Natural Resources (IUCN). Red Panda is an endangered species because it is facing a very high risk of extinction in near future.

128. Lipoproteinaceous, thromboplastin is released by the injured tissue. This reacts with Ca^{++} ions present in blood and forms a proteinaceous enzyme called prothrombinase. **Later** in the presence of Ca^{++} inactivates heparin (anticoagulant) and catalyses prothrombin (inactive plasma protein) into an active thrombin protein. Thrombin acts as an enzyme and catalyses fibrinogen (a soluble plasma protein) into an insoluble fibre like polymer, fibrin. These fibres form a dense network upon the wound and trap blood corpuscles (WBCs,

RBCs and platelets) and thus form a clot. This clot seals the wound and stop bleeding. In blood vessels, thromboplastin do not release due to which blood does not clot. But external thromboplastin to blood will cause blood clotting at the site of its introduction due to formation of prothrombinase.

129. Lac operon is a cluster of genes encoding three proteins that bacteria use to obtain energy from the sugar lactose. There are three structural genes in lac operon.

- (i) **Lac Z** (3063 bp) : This gene cods for the enzyme β galactosidase which breaks lactose into glucose and galactose to be utilized in the cell. Therefore, *E. coli* cells with a mutated Z genes of the lac operon can not grow in medium containing only lactose as the source of energy because they cannot synthesize functional β -galactosidase.
- (ii) **Lac Y** (800 bp) : It codes for β galactose permease enzyme which is a membrane bound protein and helps in transport of metabolites.
- (iii) **Lac A** (800 bp) : It codes for β galactose transacetylase an enzyme that transfers an acetyl group from acetyl Co-A to β -galactosidase.

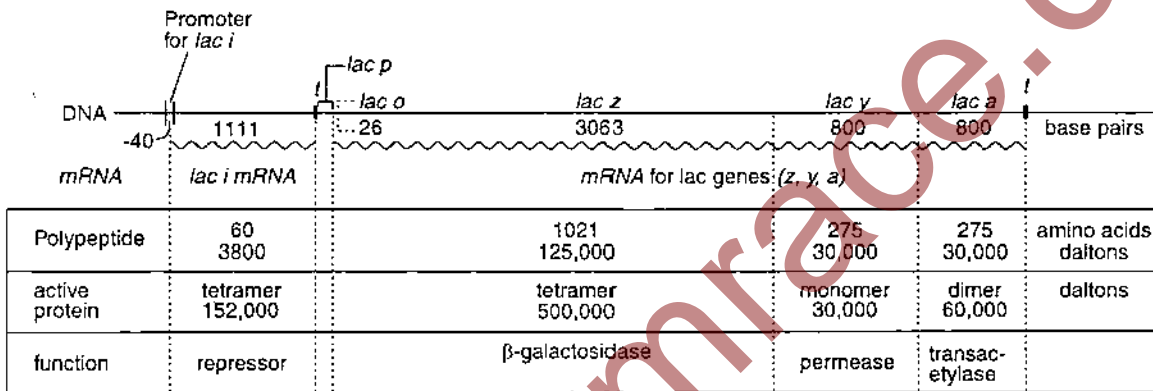

130. Cycads is a group of gymnosperms which have top shaped multiciliated male gametes (largest male gamete) and the each mature seed of these plants contain one embryo and two cotyledons (dicotyledonous) e.g., *Cycas*.

131. Genetic code has the universality i.e., a codon codes for the same amino acid in all the organisms.

132. Prawn does not have two pairs of antennae instead it has one pair of antennae and one pair of antennules.

133. Nucleotides are the building blocks of nucleic acids (DNA and RNA). A single nucleotide is composed of a phosphate molecule, a five carbon sugar (either ribose or deoxyribose) and a purine (adenine or guanine) or a

pyrimidine (cytosine or uracil) nitrogenous base.

Nucleoside = Base + Sugar

Nucleotide = Base + Sugar + Phosphate

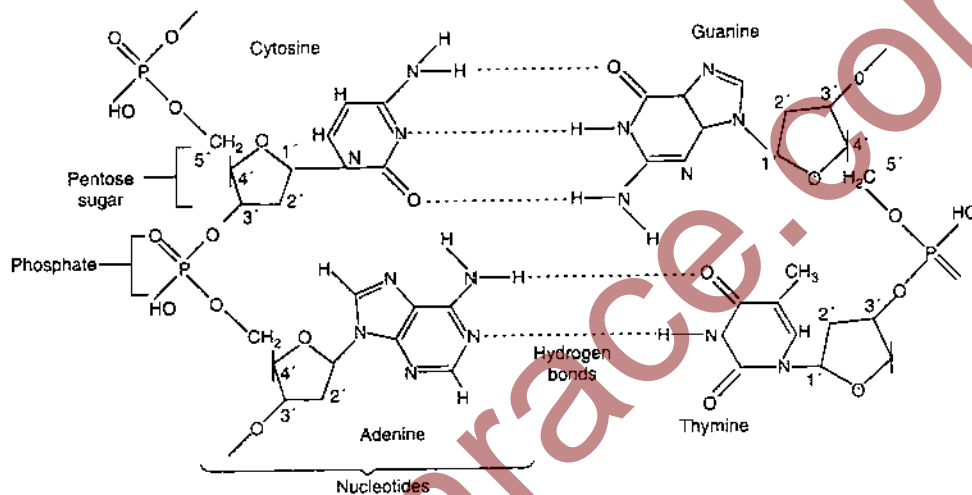

Chemical Structures of Base Pairs and Sugar Phosphate Chains

134. Three fourth surface of earth (about 71% of total) is occupied by oceans which contain 97.5% of total water. This is marine water with about 3.5% salt contents. Rest water i. e., 2.5% is fresh water which occurs on land. Most amount of this water (about 1.97%) occurs as frozen ice caps and glaciers and 0.5% freshwater occurs as ground water.
135. Solar energy is not responsible for green house effect instead it is a source of energy for the plants and animals. Green plants prepare their food by the use of this solar energy. CO_2 gas is mainly responsible for green house effect. Excess of this gas forms a thick layer around the earth and prevents re-radiation of entering sun rays to atmosphere. Thus functions like the glass panels of a green house (or the glass windows of a motor car). This is so called green house effect.
136. Ten pairs of cranial nerves are not common in mammals but common in frog. In mammals 12 pairs of cranial nerves are found.
137. Proteins are polymers of amino acids in which amino acids are joined by peptide bonds. Glycine has the simplest structure.

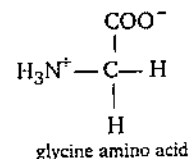

138. Barophilic prokaryotes grow and multiply in very deep marine sediments.
139. Bacillariophycean members (diatoms) form about 20% of all primary productions. These are microscopic, eukaryotic, unicellular or colonial coccoid algae. These algae are sexually reproduced by the formation of auxospores in most cases. Bozi (1914) and Fremi (1930) reported that short sections of living cells at the tips of the trichomes of *Wertiella lanosa* become invested by a thick, lamellated, pigmented sheath. Such multicellular spore like structures function as perennating bodies. They are specially modified hormogones and are called hormospores or hormocysts. Desikachary (1948) calls them pseudohormogonia.

140. Enzymes, vitamins and hormones are classified into a single category of biological chemical because all these help in regulation of metabolism. Enzyme is a proteinaceous catalyst produced by a cell and responsible for the high rate and specificity of one or more intercellular or intracellular biochemical reactions. Vitamin is an organic substance which generally synthesized by plants (exception vitamin-D). Absence of a vitamin from the diet for sufficient time gives symptoms of a resulting deficiency disease. Hormones are chemical messengers which on secretion bring about a specific and adaptive physiological response.
141. According to Darwin's concept of natural selection, the organisms which are provided with favourable variations would survive because, they are the fittest to face their surrounding while the organisms which are unfit for surrounding variations are destroyed. Prevalence of pesticide resistant insects is due to adaptability of these insects for the changes in environment (due to use of pesticides).
142. In C_4 plants every CO_2 molecule has to be fixed twice, so, these plants are needed more energy for the synthesis of hexose sugar molecules than C_3 plants in which CO_2 has to be fixed only once. 18 ATP molecules are required by C_3 plants for the synthesis of one molecule of hexose sugar while 30 ATP molecules are needed by the C_4 plants for the same. Thus C_4 plants have a need of 12 ATP molecules extra than C_3 plants for the synthesis of one molecule of hexose sugar.
143. Abducens (Abducent) nerve is a cranial nerve which originated from the ventral surface of medulla oblongata. It innervates the lateral rectus muscle of eye ball. It is a motor nerve and controls the movements of the eye ball. Hence, if abducens nerve is injured in a man, movement of eye ball will be affected.
144. Wood mainly consists of secondary xylem (sclerenchymatous cells). Lignin, in these cells provides strength to wood tissues. Preparation of pure cellulose for manufacture of pulp for paper industry from woody tissues of plants required removal of lignin from these woody tissues.
145. Protein synthesis takes place on ribosomes. In an eukaryotic cell ribosomes are present in cytoplasm, mitochondria and chloroplasts. So, in these places protein synthesis take place.
146. Gene flow means the spread of genes through populations as affected by movements of individual and their propagules e.g., Spores, seeds etc. Gene flow ensures that all populations of a given species share a common gene pool i.e., it reduces difference between populations. The interruption of gene flow between populations is a pre-requisite for the formation of new species.
147. A Botanical garden is a collection of various types of living plants. *Ex situ* conservation means conservation of plants or animals in the artificial habitats which are quite similar to the normal habitats of these organisms. In this way botanical gardens provide *ex situ* conservation of germplasm.
148. Insectivorous plants grow in water logged swampy soils, deficient in nitrogenous compounds. These plants obtain their nitrogen compounds from the insects. Due to this reason, these plants are called as semi-autotrophic or semi-heterotrophic. *Dionea* (an insectivorous plant) is commonly called as venus fly trap. Leaves of this plant have winged petiole and lamina modified into two toothed jaws. Each jaw bears several teeth. Upper surface of each jaw bears triangularly arranged long sensitive hairs or bristles and many glands, which are irregularly scattered. These hairs are very sensitive to touch stimulus. When an insect touches these hairs, this stimulus causes rapid turgor pressure changes which closes the leaf.
149. Animals resist predation by cryptic colouration, deceptive marking, behavioural defenses and the possession of mechanical or chemical defenses.
- Example :** A. Enlargement of body size by swallowing air in puffer fish.
B. Melanism in moths.
C. Colour change in chameleon.
150. Allele frequency is the relative proportion of a particular allele among individuals of a population. According to Hardy-Weinberg equation, the frequency of dominant and recessive alleles in a population will remain constant from generation to generation if there is no mutation, selection, random drift and migration.

As per Hardy-Weinberg equation

$$p^2 + 2pq + q^2 = 1$$

p = dominant allele frequency

q = recessive allele frequency

p^2 = homozygous dominant genotype

$2pq$ = heterozygous genotype

q^2 = homozygous recessive genotype

In question $p = 0.6$ and $q = 0.4$

Therefore, heterozygotes frequency is

$$= 2pq = 2 \times 0.6 \times 0.4 = 0.48.$$

151. Pasteur performed experiments in which he took sterilized (by boiling) yeast and sugar solution in a long necked, then he bent the neck of the flask like a neck of swan. After one month he observed that no life appeared in flask solution because the curved flask neck acts as a filter. He later on broken down the neck and observed the solution. He found that many micro-organisms were originated in solution.

152. According to the US office of technology assessment (1987) "biological diversity is the variety among living organisms and the ecological complexes in which they occur". Biodiversity act of India was passed by the Parliament in the year of 2002.

153. In glycolysis 4 ATP and 2 NADH_2 molecules are formed. These 2 NADH_2 molecules go to electron transport chain.

In oxidative decarboxylation no ATP molecule is formed but two molecules of NADH_2 are formed from two molecules of pyruvate. These two NADH_2 go to electron transport chain. In Krebs cycle 2 ATP, 6 NADH_2 and 2 FADH_2 molecules are formed from two molecule of acetyl Co-A. These NADH_2 and FADH_2 go to electron transport chain. In electron transport chain all NADH_2 and FADH_2 pass to electron carriers and yield 3 ATP and 2 ATP molecules per NADH_2 and FADH_2 respectively.

Thus,

4 ATP are formed in glycolysis

2 ATP in Krebs cycle and

34 ATP from electron transport chain

40 ATP

2 ATP molecules are used during glycolysis.

So, net gain of ATP molecules during one complete oxidation of a glucose molecule is 38 ATP.

154. Colourblindness is a sex linked (X-linked) trait. It always transfers from mother to son.

A woman, whose father was colour blind, will be carrier for colour blind trait. Marriage of this woman with a colourblind man will result of the above possibilities.

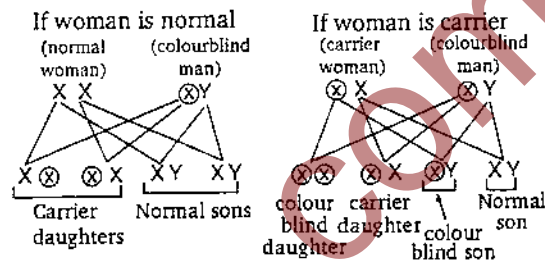

155. In the ectophloic siphonostele the xylem surrounds pith and this xylem is surrounded by phloem, pericycle and endoderm is respectively.

e.g., *Osmunda* and *Equisetum*.

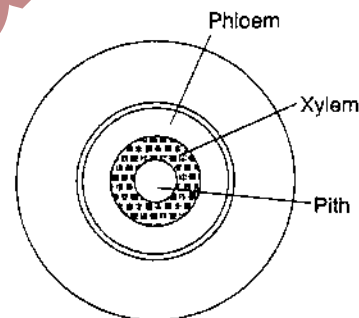

Ectophloic Siphonostele

156. The edible part of the fruit of litchi is juicy aril. Aril is an accessory seed covering formed by an outgrowth at the base of the ovule.

157. Some photosynthetic bacteria such as *Rhodospseudomonas* can prepare carbohydrates. But during this type of food synthesis O_2 does not evolved because in this case hydrogen donor is other than H_2O . Algae (green and blue green) and all green plant cells prepare their food (carbohydrate) through photosynthesis.

Here, hydrogen ions are donated by water molecules by the process of photolysis of water i.e., O_2 is released during this type of food synthesis.

158. In Kyoto protocol (Dec. 1997), it was determined that the climatic changes due to green house gases will be lower down till 2012.
159. Cretinism is a disorder which is caused by deficiency of thyroid hormones in infants. Symptoms of this disorder are slow body growth and mental development, slow heart beat, low blood pressure, stunted growth, retarded sexual development etc. This disease can be treated by an early administration of thyroid hormones.
160. Micronutrients are minerals obtained from the soil and present in plant tissues at concentrations usually less than $3 \mu\text{mol g}^{-1}$ dry matter. Cu (copper), Mn (manganese) and Fe (Iron) are those micronutrients which affect both photosynthesis and mitochondrial electron transport because they are the main constituents of various electron carriers.
161. Hugo de Vries (1848-1935) proposed mutation theory for the formation of new species. According to him, new species are not formed by continuous variations but by sudden appearance of variations which he assigned as mutations. He stated that these mutations are heritable and persist in successive generations. For proposing this theory he performed experiments on *Oenothera lamarckiana* (evening primrose).
162. Peristalsis of intestine is related with autonomous nervous system whereas knee-jerk response, pupillary reflex and swallowing of food are related to reflex action.
163. Phenyl is not used for disinfection of drinking water. Other three compounds are used in disinfection of drinking water.
164. Chemiosmotic hypothesis for oxidative phosphorylation (ATP synthesis) was proposed by Peter Mitchell in 1961 for this he was awarded Nobel prize in 1978. This theory is based on proton gradient.
165. Deficiency of dopamine in the human produces symptoms of Parkinson's disease.
166. *Frankia* is a bacterium, it grows in symbiotic association with the roots of at least eight families of higher non-leguminous plants. It can fix atmospheric nitrogen. But in the free living state it cannot do this.
167. An acromian process is found in pectoral girdle of mammals.
168. Apomixis does not involve gamete formation and fertilization as found in amphimixis. Adventive embryo formation is a type of apomixis in which embryos are formed from diploid integumental or nucellar cells.
169. Egg apparatus is present towards the micropylar end of an ovule. Egg apparatus has two lateral synergid cells and one centrally located egg cell. During entry of pollen tube within the ovule synergid cells become disintegrate and provide path for entry of pollen tube within the chamber of embryo sac.
170. The mucosa and sub-mucosa of small intestine are thrown into folds. Surfaces of these folds is covered by fine, fingerlike projections of the epithelium. These projections are called villi. In addition, the epithelial cells of the villi are covered on their exposed surface by cytoplasmic projections called microvilli.
171. The deficiency of proteins within the body is responsible for a disease, known as kwashiorkor. So, a kwashiorkor diseased patient is generally advised to specially, consume more meat, lentils, milk and eggs because these are rich sources of protein.
172. Prairies contain tall grasses and shrubs :
Savanna—Acacia trees
Tundra—permafrost
Coniferous forest—evergreen trees.
173. Electron spin resonance method is the most accurate method for dating of fossils.
174. In an amphitropous ovule, the embryo sac becomes horse-shoe shaped and the funiculus and micropyle are close to each other. This type of ovule is found in Alismaceae, Butamaceae families.

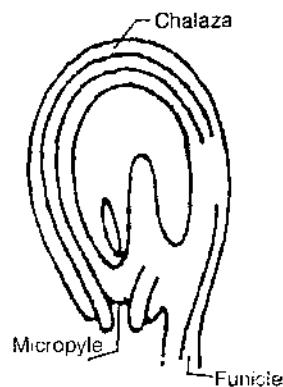

175. Evaporation of water in the form of vapours from aerial parts of a living plant is known as transpiration. Measurement of transpiration can be done with the help of potometer. It works on the principle of amount of water absorbed equals the amount of water transpired.
176. Primary tissues are those meristematic tissues which are derived directly from embryonal tissues.
e.g., Shoot apex and root apex.
177. In 1970 H. Temin and D. Baltimore independently discovered the enzyme reverse transcriptase. This enzyme uses RNA as template for the synthesis of C-DNA (Complementary DNA).
RNA
↓ Reverse transcriptase used RNA as template
C-DNA
178. Platyhelminths do not have a coelomic or pseudocoelomic cavity for digestion of food as found in higher organisms. Because these organisms obtain digested food directly.
179. A competitive inhibitor competes with substrate molecule for occupying the active site of an enzyme. These inhibitors have structural resemblance with substrate molecules due to which they easily get active site of an enzyme and form an enzyme-inhibitor complex.
$$E + I \rightarrow EI \text{ complex}$$

(enzyme) (inhibitor)
180. Gliding joint is present between zygapophyses of the successive vertebrae.
181. The K_m (Michaelis constant) can vary greatly from enzyme to enzyme and even for the different substrates of the same enzyme.
182. Plates having streptomycin allow to propagate only those bacteria which are resistant to the antibiotic.
183. Gamma rays (from cobalt 60) is generally used for induced mutation in crop plants.
184. Haemophilia, a hereditary (recessive X-linked) disease is caused due to fault in genes which controlling the factor VIII and IX, located on X-chromosome. The male carries only one X-chromosome, his other sex chromosome which carries no genes for blood clotting, so the condition is usually seen only in males where only one faulty chromosome is needed.
While a female with one faulty X-chromosome will be carrier. So, in females two faulty X-chromosomes are needed to cause the disease.
185. Down's syndrome is due to an extra chromosome which combines to the chromosome pair 21. Down syndrome is caused due to trisomy, in which the fusion of a normal n gamete (haploid) takes place with an $n + 1$ gamete (diploid). J. Langdon Down first described the developmental defect produced by trisomy in 1866. For this reason it is called Down's syndrome. Persons having Down's syndrome generally have a short, stocky build, short hands, flattened facial features and poor muscle tone. In addition they are mentally retarded.
186. Scientists perform test cross to find out the different types of gametes or the genotype of an unknown individual. Test cross is performed always between the F_1 heterozygous plants and pure recessive (homozygous) parent plant. So, in the given case $AaBb$ should be crossed with $aabb$.
187. The neuron are cells specialized to conduct an electrochemical current. Neuron cells do not have the capability of division (Cells are restricted in G_0 -phase).
188. Secretin and Cholecystokinin (CCK) are two main Gastrointestinal (GI) hormones secreted in duodenum of alimentary canal. CCK stimulates gall bladder contraction and thus increases the flow of bile salts into the intestine.
Secretin stimulates the release of an alkaline pancreatic fluid that neutralizes stomach acid as it enters the intestine.
189. *Paramecium* is a heterokaryotic organism i.e., it has two nuclei near the cytostome (oral shaped opening called mouth). The macronucleus, which is a conspicuous larger ellipsoidal vegetative nucleus, divides amitotically and controls the vegetative characters and micronucleus is a small compact reproductive nucleus which divides mitotically and controls the reproduction.
190. AIDS (Acquired Immuno Deficiency Syndrome) was described first time in 1981

- (Africa). It is the result of an infection by the Human Immuno Deficiency Virus (HIV). It is a lentivirus within the family of Retroviridae. Principal target cells for HIV are T₄ lymphocytes because these cells have CD₄ receptor proteins for interaction of HIV.
191. Flip-Flop or transmembrane movement is due to migration of lipid molecules from one lipid monolayer to other mono layer of lipid bilayer:
 192. If mammalian ovum fails to get fertilized, the estrogen secretion does not decrease further, while corpus luteum will disintegrate. Primary follicle starts developing and progesterone secretion rapidly declines.
 193. If a person is undergoing prolonged fasting, his urine will be found to contain abnormal quantities of ketones. During fasting energy is obtained by the oxidation of reserved fats. As a result of fatty acid oxidation large amount of ketone bodies are produced such as acetoacetate, β -hydroxybutyrate and acetone.
 194. Vivipary is the condition when seeds germinate on the plant. It is an undesirable character for annual crop plants because germinated seeds cannot be stored under normal conditions for the next season.
 195. Bioinsecticides are those biological agents which are used to control harmful insects. A bacterium, *Bacillus thuringiensis* is used for this purpose. Spores of this bacterium produce the insecticidal cry-protein. Therefore, spores, of this bacterium kill larvae of certain insects. The commercial preparations of *B. thuringiensis* contain a mixture of spores, cry-protein and an inert carrier.
 196. Balbiani (1881) was the first person who observed salivary gland chromosomes in the salivary glands of chironomous larvae. These chromosomes are very useful in gene mapping because they have endoreduplicated chromosomes. These chromosomes are formed due to the process of endoduplication or endopolyploidy or endomitosis, in this process the nuclear membrane does not rupture but chromosomes become double and they do not separate from each other.
 197. The deficiency of vitamin B₁ or thiamine is responsible for the disease beri-beri. This disease occurs in those countries where the staple diet is polished rice. The symptoms of this disease are pain from neuritis, paralysis, muscle wasting, progressive oedema, mental deterioration and finally heart failure.
 198. The cosmic rays, X-rays, UV-rays, the visible spectrum, infra red rays, radio waves, coming from sun are constituted electromagnetic spectrum. The waves of each of these types have a characteristic range of wavelengths. The visible spectrum, which is also known as Photosynthetic Active Radiation (PAR), has a range of wavelength of 380 nm to 760 nm. This part of electromagnetic spectrum is responsible for photosynthesis.
 199. Generally seeds of rice do not have vitamin A, but golden rice which is developed through genetic engineering has the high vitamin A content.
 200. Valium depresses brain activity and produces feeling of calmness, relaxation and drowsiness.

□