

Orkut community Link :

<http://www.orkut.co.in/Main#Community.aspx?cmm=87239458>

DRDO SET 2008 - Mechanical Engg. Question Paper

ME : Mechanical Engineering		Code
Time : 10.00 to 13.00 hrs	Name of the Candidate: _____	
Registration No.: _____	_____	
Signature of Candidate	Signature of Invigilator	

Please read the following instructions carefully

1. Verify that this question paper booklet contains **32 pages** (including **5 blank pages** for rough work) and **150 questions**.
2. There are **two sections** in this question paper - **Section A** with **100 questions** and **Section B** with **50 questions**.
3. This question paper booklet has a paper code either X or Y. **If your question paper code is X, then you must have an Objective Response Sheet (ORS) with code X. If your question paper code is Y, then you must have an Objective Response Sheet (ORS) with code Y. If there is a mismatch exchange the booklet.**
4. All answers are to be marked only on the **Objective Response Sheet (ORS)**.
5. Every question has 4 choices (A), (B), (C) and (D) for the answer and only **ONE** of them is the most appropriate answer. Darken only one bubble, which you consider to be the correct answer, from among the four choices.
6. The question booklet along with the ORS must be handed over to the Invigilator before leaving the examination hall.
7. Blank papers, clip boards, log tables, slide rules, calculators, cellular phones, pagers and electronic gadget in any form are **NOT** allowed.
8. Write your **Name** and **Registration Number** and put your **signature** in the space provided above.
9. **Using a good quality Blue/Black pen, write your Registration Number, Subject Code and Question Booklet Code in the boxes provided on the ORS answer sheet and darken the appropriate bubble under each digit with HB Pencil.**
10. Write your Name and put your signature in the appropriate boxes of ORS. Do **NOT** write these anywhere else.

Marking Scheme

- (a) In Section A, you will be awarded (+4) marks for each correct answer and (-1) mark for each wrong answer. In Section B, you will be awarded (+2) marks for every correct answer and (-½) mark for each wrong answer.
- (b) In case you have not darkened any bubble for a question you will be awarded Zero (0) marks for that question.

08-ME-Y-1/32

Orkut community Link :

<http://www.orkut.co.in/Main#Community.aspx?cmm=87239458>

Orkut community Link :

<http://www.orkut.co.in/Main#Community.aspx?cmm=87239458>

Section - A

- In the case of a curved beam subjected to pure bending, which of the following is true?
 - Neutral axis coincides with the centroidal axis.
 - Neutral axis lies between the centroidal axis and the center of curvature.
 - Location of neutral axis depends upon the magnitude of bending moment.
 - There is no neutral axis.
- A 10 m radius thin spherical tank is to be used to store gas. If the wall thickness of the tank is 10 mm and the allowable tensile stress for the material of the tank is 125 MPa, the maximum possible gas pressure (neglecting radial stress) is
 - 0.25 MPa
 - 0.125 MPa
 - 0.5 MPa
 - 1 MPa
- Natural frequency (rad/s) of mass M on the free end of a cantilever beam of negligible mass, length L and flexural rigidity EI (Fig.Q3) is

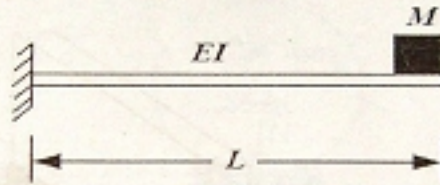

Fig.Q3

- $\sqrt{\frac{EI}{3ML^3}}$
- $\frac{1}{3}\sqrt{\frac{EI}{ML^3}}$
- $\sqrt{\frac{3EI}{ML^3}}$
- $3\sqrt{\frac{EI}{ML^3}}$

- For the system shown in Fig.Q4, the angular displacement θ is measured from the static equilibrium position. Assuming small θ , the undamped natural frequency of the system in rad/s is

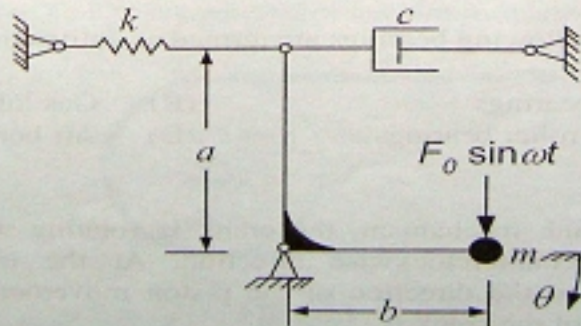

Fig.Q4

- $\frac{a}{b}\sqrt{\frac{k}{m}}$
- $\frac{b}{a}\sqrt{\frac{k}{m}}$
- $\sqrt{\frac{ak}{bm}}$
- $\sqrt{\frac{bk}{am}}$

Orkut community Link :

<http://www.orkut.co.in/Main#Community.aspx?cmm=87239458>

Orkut community Link :

<http://www.orkut.co.in/Main#Community.aspx?cmm=87239458>

5. For a one degree of freedom system described by the differential equation $10\ddot{x} + 200\dot{x} + 810x = 0$ (units as per SI system), which of the following is true?
- (A) The system is under damped.
 - (B) The system is over damped.
 - (C) The system is critically damped.
 - (D) The system has no damping.

6. Spur gears are used for
- (A) connecting two intersecting shafts
 - (B) transmitting power between two intersecting shafts
 - (C) transmitting power between two parallel shafts
 - (D) transmitting power between two inline shafts

7. A 6 mm fillet weld is 50 mm long and carries a steady load of 12000 N along the weld as shown in Fig.Q7. The weld metal has yield strength of 360 MPa. The value of factor of safety is

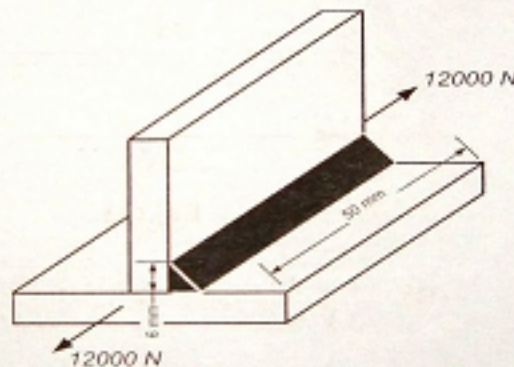

Fig.Q7

- (A) 1.59 (B) 3.18 (C) 4.18 (D) 6.36
8. Which of the following bearings are termed as antifriction bearings?
- (A) Journal bearings
 - (B) Gas lubricated bearings
 - (C) Ball and roller bearings
 - (D) Air bearings
9. In a slider-crank mechanism, the crank is rotating with an angular velocity of 20 rad/s in counterclockwise direction. At the instant when the crank is perpendicular to the direction of the piston movement, velocity of the piston is 2 m/s. Radius of the crank is
- (A) 100 cm
 - (B) 10 cm
 - (C) 1 cm
 - (D) 0.1 cm

Orkut community Link :

<http://www.orkut.co.in/Main#Community.aspx?cmm=87239458>

Orkut community Link :

<http://www.orkut.co.in/Main#Community.aspx?cmm=87239458>

10. Two parallel shafts whose axes are separated by a distance of 75 mm are to be connected by a spur gear set so that the output shaft rotates at 50% of the speed of the input shaft. Which of the following could be the possible pitch circle diameters of the gears?

- (A) 25 mm and 50 mm (B) 30 mm and 60 mm
(C) 50 mm and 100 mm (D) 60 mm and 120 mm

11. A square key is used to key a gear to a 40 mm diameter shaft. The hub length of the gear is 50 mm. Both shaft and the key are made of same material having allowable shear strength of 50 MPa. If a torque of 500 N-m is to be transmitted, what is the minimum value of the dimension of the sides of the square key?

- (A) 20 mm (B) 10 mm (C) 5 mm (D) 1 mm

12. A 250 mm radius brake drum contacts a single shoe as shown in Fig.Q12 and sustains a torque of 300 N-m at 500 rpm. Coefficient of friction is 0.3. Force F required for braking in the case of counterclockwise rotation of the brake drum is

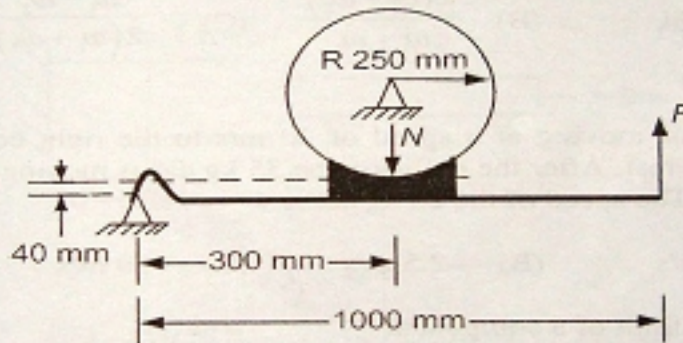

Fig.Q12

- (A) 1152 N (B) 1248 N (C) 4000 N (D) 2000 N

13. The motion of a pulley (Fig.Q13) is controlled by cable C which has a constant acceleration of 0.225 m/s^2 . The magnitude of angular acceleration of the pulley is

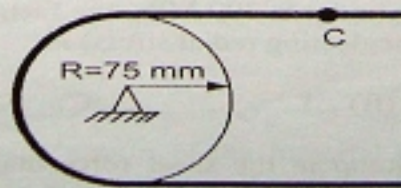

Fig.Q13

- (A) 3 rad/s^2 (B) 4 rad/s^2 (C) 225 rad/s^2 (D) 6 rad/s^2

Orkut community Link :

<http://www.orkut.co.in/Main#Community.aspx?cmm=87239458>

Orkut community Link :

<http://www.orkut.co.in/Main#Community.aspx?cmm=87239458>

14. Which of the following is a flexible coupling?
- (A) Muff coupling (B) Marine coupling
(C) Protected type flange coupling (D) Oldham coupling
15. Two concentric helical springs with spring constants 200 N/mm and 160 N/mm when subjected to a load of 1800 N will deflect by
- (A) 5 mm (B) 10 mm (C) 20.25 mm (D) 40.5 mm
16. Tearing efficiency of a double riveted lap joint having a pitch of 60 mm and rivet hole diameter of 18 mm is
- (A) 30% (B) 35% (C) 60% (D) 70%
17. For a fly wheel operating between maximum and minimum speeds of ω_1 and ω_2 respectively, coefficient of fluctuation of speed is
- (A) $\omega_1 - \omega_2$ (B) $\frac{2(\omega_1 - \omega_2)}{\omega_1 + \omega_2}$ (C) $\frac{\omega_1 - \omega_2}{2(\omega_1 + \omega_2)}$ (D) $\frac{\omega_1 - \omega_2}{\omega_1}$
18. A 20 kg car moving at a speed of 20 m/s to the right collides with a 35 kg car which is at rest. After the collision the 35 kg car is moving towards right at a speed of 10 m/s. The speed of the 20 kg car is
- (A) 2.5 m/s (B) -2.5 m/s (C) 50 m/s (D) 0
19. Endurance limit of a component
- (A) increases as the surface roughness increases
(B) decreases as the surface roughness increases
(C) initially increases with the increase in surface roughness and then decreases
(D) does not depend upon the surface roughness
20. A thin cylindrical pressure vessel with mean diameter 10 m and wall thickness 20 mm is subjected to an internal fluid pressure of 0.4 MPa. If the yield strength of the material of the cylinder is 200 MPa, the factor of safety according to maximum shear stress theory (neglecting radial stress) is
- (A) 0.5 (B) 1 (C) 1.5 (D) 2
21. A discontinuity or jump in the shear force diagram occurs whenever a beam is loaded by
- (A) a distributed moment
(B) a distributed force
(C) a concentrated moment
(D) a concentrated force

Orkut community Link :

<http://www.orkut.co.in/Main#Community.aspx?cmm=87239458>

22. For the beam loaded as shown in Fig.Q22 the magnitude of bending moment at the roller support is

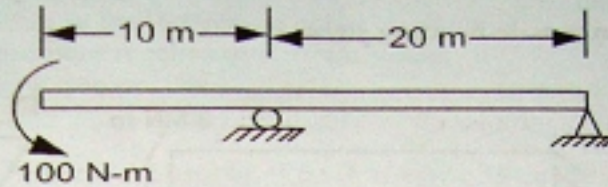

Fig.Q22

- (A) 100 N-m (B) 1000 N-m (C) 0 (D) 2000 N-m

23. A rod of variable cross-section (areas A_1 and A_2) fixed at one end is subjected to an axial force P as shown in Fig.Q23. If the allowable normal stress in tension is 100 MPa then the maximum allowable load P (neglecting stress concentration) is

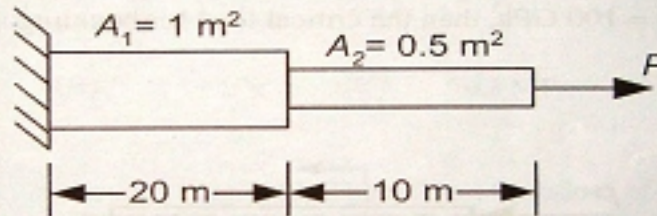

Fig.Q23

- (A) 100 MN (B) 200 MN (C) 50 MN (D) 50 N

24. When a solid circular shaft is in pure torsion and deforms elastically, the shearing stress in the shaft

- (A) is inversely proportional to the shear modulus of elasticity
 (B) varies linearly with the radial distance from the axis of the shaft
 (C) varies linearly with length of the shaft
 (D) is inversely proportional to the diameter of the shaft

25. At a point in a body the normal stresses are $\sigma_x = \sigma$ and $\sigma_y = \sigma$. E is the Young's modulus and ν is the Poisson's ratio of the material of the body. Assuming the material to be linearly elastic and isotropic, for plane stress condition the ratio of σ_x to ϵ_x is

- (A) $\frac{E}{(1-\nu)}$ (B) E (C) $\frac{E}{\nu}$ (D) $\frac{E}{(1+\nu)}$

Orkut community Link :

<http://www.orkut.co.in/Main#Community.aspx?cmm=87239458>

26. A cantilever beam has the cross-section of an isosceles triangle and is loaded as shown in Fig.Q26. If the moment of inertia of the cross-section $I_{zz} = \frac{1}{36} \text{ m}^4$, then the maximum tensile bending stress is

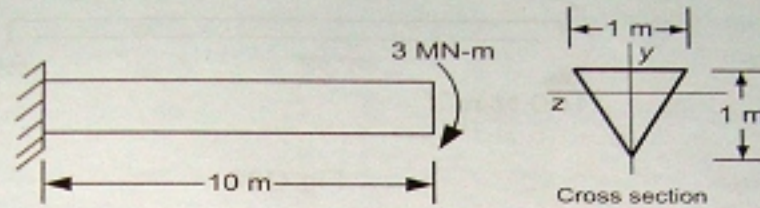

Fig.Q26

- (A) 1/16 MPa (B) 72 MPa (C) 36 MPa (D) 1/36 MPa
27. A long, slender column is pin-supported at the ends and compressed by an axial load P as shown in Fig.Q27. If $I_{11} = 100 \text{ cm}^4$, $I_{22} = 200 \text{ cm}^4$ and Young's modulus of elasticity = 100 GPa, then the critical load for buckling is

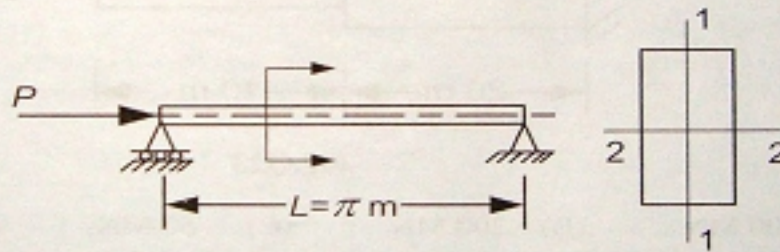

Fig.Q27

- (A) 500 kN (B) 200 kN (C) 100 kN (D) 1000 GN
28. The linear relation between the stress and strain of a material is valid until
- (A) fracture stress
(B) elastic limit
(C) ultimate stress
(D) proportional limit
29. Which of the following can be the measure of ductility of a material?
- (A) Area under engineering stress-strain curve
(B) Percent reduction in area in tension test
(C) Yield stress
(D) Ultimate stress

Orkut community Link :

<http://www.orkut.co.in/Main#Community.aspx?cmm=87239458>

Orkut community Link :

<http://www.orkut.co.in/Main#Community.aspx?cmm=87239458>

30. At the point of contraflexure of a beam
- (A) the shear force is zero
 - (B) sign of curvature in the deflection curve changes
 - (C) the bending moment reaches maximum value
 - (D) maximum deflection occurs
31. A material has a Poisson's ratio of 0.5. If a body is made of this material and subjected to external forces (within the elastic limit) then the final volume of the body is
- (A) thrice that of the initial volume of the body
 - (B) twice that of the initial volume of the body
 - (C) zero
 - (D) equal to the initial volume of the body
32. If at a point in a body $\sigma_x = 70$ MPa, $\sigma_y = 60$ MPa and $\tau_{xy} = -5$ MPa then the radius of the Mohr's circle is equal to
- (A) $5\sqrt{5}$ MPa
 - (B) $2\sqrt{5}$ MPa
 - (C) $5\sqrt{2}$ MPa
 - (D) 25 MPa
33. A rectangular area is shown in Fig.Q33. The value of product of inertia I_{xy} is

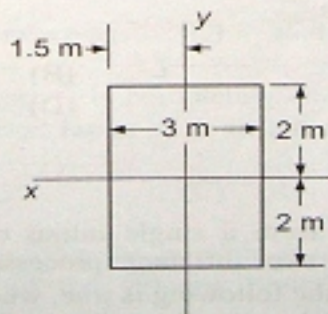

Fig.Q33

- (A) 12 m^4
 - (B) 16 m^4
 - (C) 9 m^4
 - (D) 0
34. Hinge support is not capable of resisting
- (A) horizontal force
 - (B) moment
 - (C) vertical force
 - (D) both horizontal and vertical forces

08-ME-Y-9/32

Orkut community Link :

<http://www.orkut.co.in/Main#Community.aspx?cmm=87239458>

Orkut community Link :

<http://www.orkut.co.in/Main#Community.aspx?cmm=87239458>

35. The axial force in the member BD of a steel truss shown in Fig.Q35 is

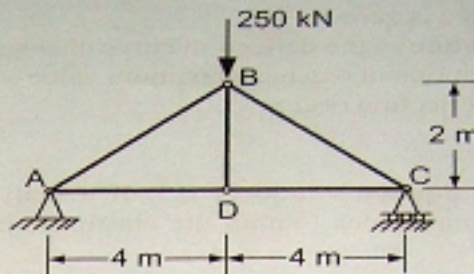

Fig.Q35

- (A) 250 kN (B) -250 kN (C) 0 (D) 125 kN
36. The motion of a particle is defined by the relation $x = \frac{5}{2}t^2 - 20t + 10$, where x and t are expressed in meters and seconds respectively. The position x of the particle at zero velocity is
- (A) 30 m (B) -30 m (C) -20 m (D) 50 m
37. For any process, the second law of thermodynamics requires that the entropy change of the system be
- (A) positive or zero (B) zero
(C) negative or zero (D) positive, zero or negative, but does not say which
38. A system is changed from a single initial equilibrium state to the same final equilibrium state by two different processes, one reversible and the other irreversible. Which of the following is true, where ΔS refer to the change in entropy of the system?
- (A) $\Delta S_{irr} = \Delta S_{rev}$ (B) $\Delta S_{irr} > \Delta S_{rev}$
(C) $\Delta S_{irr} < \Delta S_{rev}$ (D) either (B) or (C) depending on the nature of the process
39. An inventor claims to have devised an engine that produces 2000 kJ of work while receiving 1900 kJ of heat from a single reservoir during a complete cycle of the engine. Such an engine would violate
- (A) only the first law of thermodynamics and no other laws
(B) only the second law of thermodynamics and no other laws
(C) both the first and the second laws of thermodynamics
(D) neither the first nor the second laws of thermodynamics

08-ME-Y-10/32

Orkut community Link :

<http://www.orkut.co.in/Main#Community.aspx?cmm=87239458>

Orkut community Link :

<http://www.orkut.co.in/Main#Community.aspx?cmm=87239458>

40. The COP of a Carnot heat pump operating between -3°C and 27°C is
(A) 10.0 (B) 9.0 (C) 0.111 (D) 0.10
41. A vessel of volume 1 m^3 contains oxygen (molecular weight = 32) at $p = 1\text{ bar}$ and $T = 47^{\circ}\text{C}$. The mass of oxygen in the vessel is (take universal gas constant as 8314 J/kmol-K)
(A) 40.0 kg (B) 3.0 kg (C) 1.2 kg (D) 1.0 kg
42. For water boiling at constant pressure of 1 bar, the specific heat is
(A) zero (B) very small but positive
(C) negative (D) infinitely large
43. An inventor claims to have constructed a device that rejects 300 kJ of heat to a single reservoir while absorbing 300 kJ of work during a single cycle of the device. This device violates
(A) only the first law of thermodynamics and no other laws
(B) only the second law of thermodynamics and no other laws
(C) both the first and the second laws of thermodynamics
(D) neither the first nor the second law of thermodynamics
44. A man sits on the floor by a fire burning at some distance at the same level. The mode of heat transfer mainly responsible for the man receiving heat is
(A) conduction (B) convection (C) radiation (D) advection
45. A spherical body with surface A_1 is completely enclosed by another hollow body with inner surface A_2 . The shape factor of A_2 with respect to A_1 is
(A) 0.0 (B) 0.5 (C) 1.0 (D) π
46. For the laminar flow of air (Prandtl number = 0.71) over a flat plate at zero incidence, the thicknesses of the velocity boundary layer δ and the thermal boundary layer δ_t are such that
(A) $\delta_t > \delta$ (B) $\delta_t = \delta$ (C) $\delta_t < \delta$ (D) $0.5 \leq \delta_t/\delta \leq 1.5$
47. As the thickness of insulation around a heated cable gradually increases from zero, heat transfer from the conductor
(A) goes on decreasing monotonically
(B) goes on increasing monotonically
(C) first increases and then decreases
(D) first decreases and then increases

08-ME-Y-11/32

Orkut community Link :

<http://www.orkut.co.in/Main#Community.aspx?cmm=87239458>

Orkut community Link :

<http://www.orkut.co.in/Main#Community.aspx?cmm=87239458>

48. Arrangement of silver, air, aluminium and lead in the order of increasing thermal conductivity at room temperature yields
- (A) air, aluminium, silver, lead (B) air, aluminium, lead, silver
(C) lead, air, aluminium, silver (D) air, lead, aluminium, silver
49. For a 2D rotational flow the Laplacian of the stream-function at any point in the flow-field
- (A) is always very large (B) is always very small
(C) equals zero (D) equals vorticity
50. In passing through a standing normal shock-wave, a subsonic flow cannot turn supersonic as it will not satisfy the
- (A) continuity equation (B) momentum equation
(C) energy equation (D) second law of thermodynamics
51. In the fully developed laminar flow through a horizontal pipe of constant cross-section
- (A) static pressure remains constant in the direction of flow
(B) Bernoulli equation holds along the axis of the pipe
(C) static pressure increases in the direction of flow
(D) static pressure decreases in the direction of flow
52. For a 1D compressible flow through a stream-tube, if ρ , u and A denote density, velocity and cross-sectional area respectively, the continuity equation can be written as
- (A) $\ln \rho + \ln A + \ln u = 0$ (B) $\frac{d\rho}{\rho} + \frac{dA}{A} + \frac{du}{u} = 0$
(C) $\frac{d\rho}{\rho} + \frac{dA}{A} + \frac{du}{u} \geq 0$ (D) $\rho Au^2 = \text{a constant}$
53. A pitot static tube is to measure the velocity of air-stream in a pipe. If the difference between the stagnation and static pressures as indicated by a vertical tube manometer is 12.5 cm of water, the velocity of the air-stream is (take $\rho_{\text{air}} = 1 \text{ kg/m}^3$, $\rho_{\text{water}} = 1000 \text{ kg/m}^3$ and $g = 10 \text{ m/s}^2$)
- (A) $5\sqrt{10}$ m/s (B) 50 m/s (C) 400 m/s (D) 500 m/s

Orkut community Link :

<http://www.orkut.co.in/Main#Community.aspx?cmm=87239458>

Orkut community Link :

<http://www.orkut.co.in/Main#Community.aspx?cmm=87239458>

54. The flight Mach number of an aircraft flying at an altitude where the temperature is -48°C is 0.7. The speed of the aircraft is (take $\gamma = 1.4$, $R = 287 \text{ J/kg-K}$)
- (A) 100 m/s (B) 140 m/s (C) 210 m/s (D) 250 m/s
55. A cylindrical vessel of large diameter is filled with water to the brim. If a small hole is made in the wall of the vessel at a depth of 1.25 m, the velocity of outflow through the orifice is (take $g = 10 \text{ m/s}^2$)
- (A) 3.5 m/s (B) 5.0 m/s (C) 15.0 m/s (D) 25.0 m/s
56. The SI unit of the term $u^2 / 2g$ that appears in the Bernoulli equation is
- (A) N/m^2 (B) m (C) J/m^3 (D) bar
57. For a cylindrical wooden block completely submerged under water, the only correct statement among the following is
- (A) Buoyancy is the largest when the axis is horizontal
(B) Buoyancy is the largest when the axis is vertical
(C) Buoyancy increases with the depth at which the body is kept
(D) Buoyancy is independent of the vertical position and orientation
58. In the converging part of a horizontal venturi meter
- (A) static pressure gradually decreases
(B) static pressure gradually increases
(C) axial velocity gradually decreases
(D) both the static pressure and axial velocity gradually decreases
59. A steady flow of fluid crossing a normal shock-wave undergoes a sudden rise in
- (A) stagnation pressure
(B) stagnation temperature
(C) static pressure accompanied by a fall in static temperature
(D) both static pressure and static temperature
60. Cavitation is a phenomenon observed
- (A) only in centrifugal pumps
(B) only in hydraulic reaction turbines like Francis and Kaplan
(C) only in marine propellers
(D) in all of centrifugal pumps, hydraulic reaction turbines and marine propellers
61. For an axial-flow turbine rotor with mass flow rate 10 kg/s, a change in whirl of 60 m/s and a blade speed of 30 m/s, the Euler equation of turbomachines gives that the specific work done by
- (A) the fluid on the rotor is 1800 J/kg
(B) the fluid on the rotor is 18000 W
(C) the turbine rotor on the fluid is 18000 J/kg
(D) the turbine rotor on the fluid is 18000 W

08-ME-Y-13/32

Orkut community Link :

<http://www.orkut.co.in/Main#Community.aspx?cmm=87239458>

Orkut community Link :

<http://www.orkut.co.in/Main#Community.aspx?cmm=87239458>

62. In a variable speed SI engine
- (A) both the torque and power are maximum at the same speed
 - (B) maximum torque occurs at a speed higher than that at which maximum power occurs
 - (C) maximum torque occurs at a speed lower than that at which maximum power occurs
 - (D) power goes on increasing monotonically with speed
63. In an SI engine very high compression ratio cannot be used because
- (A) the engine efficiency would be unmanageably high
 - (B) the power required for compression would be high
 - (C) cylinders will require very thick walls
 - (D) self-ignition may take place before the spark occurs
64. In a centrifugal compressor the stagnation temperature across the impeller
- (A) increases
 - (B) decreases
 - (C) does not show a monotonic trend
 - (D) remains constant
65. When moist air in a closed vessel is heated the specific humidity
- (A) increases
 - (B) decreases
 - (C) remains constant
 - (D) may increase or decrease
66. The ideal cycle for a steam power plant is the Rankine cycle instead of the Carnot cycle because
- (A) the Rankine cycle has higher efficiency
 - (B) the Rankine cycle efficiency equals the Carnot cycle efficiency
 - (C) the Rankine cycle has higher work ratio and is easier to implement
 - (D) the Carnot cycle gives lower turbine work
67. The only correct statement related to hydraulic turbines among the following is
- (A) Pelton wheel and Francis turbine are impulse turbines
 - (B) The adjustable blade Kaplan turbine has a higher part-load efficiency compared to a Francis turbine
 - (C) A draft tube can improve the performance of a Pelton wheel
 - (D) Cavitation occurs at the entry to a Francis turbine
68. Clothes dry relatively easily in an environment where the
- (A) relative humidity is high
 - (B) specific humidity is high
 - (C) relative humidity is low
 - (D) relative humidity fluctuates

Orkut community Link :

<http://www.orkut.co.in/Main#Community.aspx?cmm=87239458>

Orkut community Link :

<http://www.orkut.co.in/Main#Community.aspx?cmm=87239458>

69. The main function of the draft tube in a hydraulic reaction turbine is to
- (A) reduce the effective head across the turbine
 - (B) increase the discharge and hence the work
 - (C) decrease the discharge to prevent flow separation
 - (D) increase the effective head across the turbine
70. In a 50% reaction stage of a gas turbine
- (A) the static enthalpy drop in the stator is greater than that in the rotor
 - (B) the static enthalpy rise in the rotor is greater than that in the stator
 - (C) the static enthalpy rise in the stator is greater than that in the rotor
 - (D) the stage static enthalpy drop is equally shared by the rotor and stator
71. The structure of austenite is
- (A) body-centered cubic
 - (B) face-centered cubic
 - (C) hexagonal close-packed
 - (D) body-centered tetragonal
72. Doubling the frequency of current in an induction hardening process
- (A) doubles the depth of hardening
 - (B) halves the depth of hardening
 - (C) increases the depth of hardening by a factor of $\sqrt{2}$
 - (D) reduces the depth of hardening by a factor of $\sqrt{2}$
73. When a uniaxial tensile load is applied to a rod fixed at one end,
- (A) both engineering stress and true stress in the rod depend on the type of material of the rod
 - (B) engineering stress in the rod depends on the type of material of the rod, but true stress in the rod does not depend on the type of material of the rod
 - (C) true stress in the rod depends on the type of material of the rod, but engineering stress in the rod does not depend on the type of material of the rod
 - (D) both engineering stress and true stress in the rod does not depend on the type of material of the rod
74. Chaplets are used in the mold for
- (A) enhancing the rate of solidification
 - (B) providing additional metal to the casting as it shrinks
 - (C) carrying off gases produced during casting
 - (D) providing support to the core
75. Keeping the surface area constant, if the volume of a casting is doubled by changing its design, the solidification time is expected to increase by a factor of
- (A) $\sqrt{2}$
 - (B) 2
 - (C) 4
 - (D) 8

08-ME-Y-15/32

Orkut community Link :

<http://www.orkut.co.in/Main#Community.aspx?cmm=87239458>

Orkut community Link :

<http://www.orkut.co.in/Main#Community.aspx?cmm=87239458>

76. When the molten metal is poured in a mold, it may pass through the following items in sequence:
- (A) sprue, runner, gate, top riser (B) runner, sprue, gate, top riser
(C) top riser, runner, sprue, gate (D) gate, sprue, top riser, runner
77. The shear yield stress of a ductile metal in plane-strain state is k . If the maximum shear stress in the material becomes k , the metal yields according to
- (A) Tresca criterion, but not according to von Mises criterion
(B) von Mises criterion, but not according to Tresca criterion
(C) von Mises as well as Tresca criteria
(D) Tresca criterion, but not according to maximum distortion energy criterion
78. Which of the following statements is true for a cold flat rolling process?
- (A) Both front and back tension reduce the roll force.
(B) Front tension increases the roll force and back tension reduces the roll force.
(C) Both front and back tension increase the roll force.
(D) Back tension increases the roll force and front tension reduces the roll force.
79. If the extrusion ratio is 20, the percentage reduction in the cross-sectional area of the billet after the extrusion will be
- (A) 98% (B) 95% (C) 20% (D) 5%
80. In a straight turning operation, if the depth of cut is doubled, then uncut chip thickness will
- (A) get doubled (B) get halved
(C) remain same (D) get quadrupled
81. For a single-pass turning process for which the tool life decreases with increase in cutting speed, the optimum cutting speed for maximum production rate is
- (A) always less than the optimum cutting speed for minimum cost per piece
(B) always more than the optimum cutting speed for minimum cost per piece
(C) always equal to the optimum cutting speed for minimum cost per piece
(D) less than the optimum cutting speed for minimum cost per piece, if the tool cost is very high
82. The process in which the material removal rate is governed by Faraday's law is
- (A) electro-chemical machining (B) electro-discharge machining
(C) abrasive jet machining (D) laser beam machining
83. 20 H7-g6 is a
- (A) clearance fit (B) transition fit
(C) interference fit (D) push fit

08-ME-Y-16/32

Orkut community Link :

<http://www.orkut.co.in/Main#Community.aspx?cmm=87239458>

Orkut community Link :

<http://www.orkut.co.in/Main#Community.aspx?cmm=87239458>

84. An optical flat measures the flatness of a surface by using the principle of
- (A) dispersion of light (B) interference
(C) total internal reflection of light (D) optical contour projection
85. The peak to valley surface roughness in a machining operation is $32 \mu\text{m}$. Assuming that the surface roughness profile is triangular, the center-line average surface roughness is
- (A) $4 \mu\text{m}$ (B) $8 \mu\text{m}$ (C) $16 \mu\text{m}$ (D) $32 \mu\text{m}$
86. Which of the following is a correct statement about spot welding, seam welding, friction welding and roll bonding?
- (A) All are fusion welding processes.
(B) All are solid-state welding processes.
(C) Seam welding is a fusion welding process and other three are solid-state welding processes.
(D) Roll bonding is a fusion welding process and other three are solid-state welding processes.
87. The temperatures employed in brazing are
- (A) below the melting point of the metals to be joined
(B) above the melting point of the metals to be joined
(C) below the melting point of the filler metal
(D) same as those employed in soldering
88. When two plates are butt welded, residual stresses get generated in the welded structure. The residual stresses are
- (A) tensile at the butt joint and compressive away from the joint
(B) compressive at the butt joint and tensile away from the joint
(C) tensile everywhere
(D) compressive in one plate and tensile in other plate
89. In the context of computer-aided design (CAD), STEP means
- (A) Standard for the Exchange of Product Model Data
(B) Solid Three-dimensional Engineering Product
(C) Solid Technology and Engineering Product
(D) Standard Three-dimensional Engineering Package

08-ME-Y-17/32

Orkut community Link :

<http://www.orkut.co.in/Main#Community.aspx?cmm=87239458>

Orkut community Link :

<http://www.orkut.co.in/Main#Community.aspx?cmm=87239458>

90. Determine the correctness or otherwise of the following **Assertion [a]** and the **Reason [r]**:
Assertion: The generative system of computer-aided process planning is more complex than the variant system.
Reason: The generative system has the capability of creating a new plan instead of using and modifying the existing plan. This system has to use some type of expert system.
- (A) Both [a] and [r] are true and [r] is the correct reason for [a]
(B) Both [a] and [r] are true, but [r] is not the correct reason for [a]
(C) Both [a] and [r] are false
(D) [a] is true but [r] is false
91. Which of the following is not a feedback device of a CNC machine?
- (A) Tachogenerator (B) Encoder
(C) Linear scale (D) Comparator
92. In orthogonal machining process, the shear angle decreases if the
- (A) rake angle decreases
(B) rake angle increases
(C) friction at the tool-chip interface decreases
(D) friction at the tool-work interface decreases
93. MRP-II means
- (A) Materials Requirement Planning (B) Manufacturing Resource Planning
(C) Man Requirement Planning (D) Money Requirement Planning
94. According to the simple exponential smoothing model of forecasting:
 $S_t = \alpha D_t + (1 - \alpha)S_{t-1}$
where D_t is the demand in period t , S_t is the estimated mean demand including all data up to period t and the parameter α is the proportion of weight of the most recent observation. If we choose $\alpha = 0.3$ for the monthly forecast, then for the estimation of mean demand up to March 2008, the weightage of data of January 2008 is
- (A) 0.3 (B) 0.09 (C) 0.027 (D) 0.147
95. In basic economic order quantity model, for the optimal order quantity,
- (A) holding cost is more than ordering cost
(B) holding cost is less than ordering cost
(C) holding cost is equal to ordering cost
(D) holding cost is two times the ordering cost

08-ME-Y-18/32

Orkut community Link :

<http://www.orkut.co.in/Main#Community.aspx?cmm=87239458>

Orkut community Link :

<http://www.orkut.co.in/Main#Community.aspx?cmm=87239458>

96. The probability distribution for the sale of a product is as follows:

Sale quantity	Probability
1	0.3
2	0.4
3	0.3

On the sale of an item the profit is Rs. 500. The expected profit is

- (A) Rs. 1000 (B) Rs. 500 (C) Rs. 250 (D) Rs. 200
97. The expected demand of a product is 150 per day. The lead time is 10 days. An order is placed when the inventory falls to 4000 units. The safety stock is
- (A) 1500 units (B) 2500 units (C) 3000 units (D) 4000 units
98. In a linear programming problem, if a constraint is inactive, then the unit worth of resource corresponding to that constraint is
- (A) zero (B) a high value (C) negative (D) undefined
99. Patients arrive at a doctor's clinic according to the Poisson distribution. Check up time by the doctor follows an exponential distribution. If on an average, 9 patients/hr arrive at the clinic and the doctor takes on an average 5 minutes to check a patient, the number of patients in the queue will be
- (A) 1 (B) 1.25 (C) 2.25 (D) 3.25
100. The pessimistic, most likely and optimistic times for an activity are 5 days, 3 days and 1 day respectively. Assuming Beta distribution, the expected duration of the activity is
- (A) 3 days (B) 3.5 days (C) 4 days (D) 5 days

Orkut community Link :

<http://www.orkut.co.in/Main#Community.aspx?cmm=87239458>

Orkut community Link :

<http://www.orkut.co.in/Main#Community.aspx?cmm=87239458>