

# CIVIL ENGINEERING

## (PAPER-II)

1. Match List I(Unit) with List II(Purpose) and select the correct answer :

**List I**

- A. Leaping weir
- B. Gutter inlet
- C. Inverted siphon
- D. Catch basin

**List II**

- 1. To prevent grit, sand, debris, etc. from entering the storm sewer
- 2. To carry the sewer below a stream or railway line
- 3. To drain rain water from roads to the storm sewer
- 4. To separate storm water and the sanitary sewage

	A	B	C	D
a.	4	3	1	2
b.	4	3	2	1
c.	3	4	2	1
d.	3	4	1	2

2. Match List I (Treatment units) with List II (Types of processes) and select the correct answer :

**List I**

- A. Trickling filter
- B. Activated sludge process
- C. Oxidation ditch
- D. Oxidation pond

**List II**

- 1. Symbiotic
- 2. Extended aeration
- 3. suspended growth
- 4. Attached growth

	A	B	C	D
a.	3	4	2	1
b.	4	3	1	2
c.	3	4	1	2
d.	4	3	2	1

3. If the moisture content of a sludge is reduced from 98% to 96% ,the volume of sludge will decrease by

- a. 2%
- b. 20%
- c. 25%
- d. 50%

4. In a high-rate trickling filter, the problem of ponding can be solved by

- a. flooding and raking
- b. chlorination and supply of air
- c. ranking and chlorination
- d. flooding and supply of air

5. Consider the following statements :

The process of activated sludge can be explained as

- 1. a physical action whereby the finer suspended particles of sewage form a sublayer for a bacterial film at the surface.
- 2. a chemical action whereby the finer suspended particles and colloidal solids are combined into masses of large bulk.
- 3. a biochemical action whereby the sludge flocs so formed act as vehicles for aerobic bacterial oxidizing the organic matter

Which of these statements are correct?

- a. 1, 2 and 3
- b. 1 and 2
- c. 2 and 3
- d. 1 and 3

6. Sewage may be disposed of without treatment into a water body if the available dilution is

- a. less than 150
- b. more than 150
- c. more than 300
- d. more than 500

7. A certain waste has a BOD of 162 mg/l and its flow is 1000 cubic meters per day. If the domestic sewage has a BOD of 80 gram per capita, then the population equivalent of the waste would be
- 20.25
  - 1296
  - 2025
  - 12960
8. In sanitary plumbing of buildings, a two-pipe system signifies
- Separate soil pipes and waste pipe without vent pipes
  - A soil-cum-waste pipe and a ventilating pipe
  - Separate soil and waste pipe and a common ventilating pipe
  - Separate soil pipe and waste pipe, each with its own vent pipe
9. Which of the following are storm water regulators ?
- Side weir
  - Leaping weir
  - symphonic spillway
  - Float actuated gates or valves.
  - Inverted syphon.
- Select the correct answer using the codes given below :
- 1, 2 3 and 4
  - 1, 3 and 5
  - 2, 3 4 and 5
  - 1, 2, 4 and 5
10. When wastewater is disposed of into a running stream, four zones are formed. In which one of the following zones will the minimum level of dissolved oxygen be found ?
- Zone of degradation
  - Zone of active decomposition
  - Zone of recovery
  - Zone of clear water
11. The least expensive and most suitable excrete disposal unit for rural areas would be the
- soak pit
  - pit privy
  - leaching cesspool
  - septic tank
12. Which of the following pairs are correctly matched ?
- Ringelmann chart : To grade density of smoke
  - Pneumoconiosis : Disease caused due to coal dust
  - PAN : Secondary air pollutant
- Select the correct answer using the codes given below :
- 2 and 3
  - 1 and 2
  - 1 and 3
  - 1, 2 and 3
13. Which one of the following terms correctly described 'Biomagnification'?
- Reproduction of micro-organisms
  - Observation of micro-organisms under a microscope
  - Ability of micro-organisms to form zoogeal film
  - Concentration of toxic materials in the food chain
14. Which one of the following comprehensive classifications is used for different types of solid wastes ?
- Residential, commercial and treatment plant wastes
  - Food, demolition and construction wastes
  - Municipal, industrial and hazardous wastes
  - Rubbish, special wastes and wastes from open areas
15. Which one of the following methods would be best suited for disposal of plastic and rubber waste ?
- Composting
  - Incineration
  - Pyrolysis
  - Sanitary landfill
16. Which of the following pairs are correctly matched ?
- Reverberation : time required to reduce noise by 60 dB time
  - NIPTS : Responsible for permanent hearing loss

3. Sound foci : Formed when sound waves are reflected from convex surface
4. TTS : Responsible for temporary hearing loss

Select the correct answer using the codes given below :

- a. 2, 3 and 4  
b. 1, 3 and 4  
c. 1, 2 and 4  
d. 1, 2 and 4

17. A dry soil sample has equal amounts of solids and voids by volume. Its void ratio and porosity will be

Void ratio	Porosity(%)
------------	-------------

- |        |      |
|--------|------|
| a. 1.0 | 100% |
| b. 0.5 | 50%  |
| c. 0.5 | 100% |
| d. 1.0 | 50%  |

18. Based on grain distribution analysis, the  $D_{10}$ ,  $D_{30}$  and  $D_{60}$  values of a given solid are 0.23 mm, 0.3 mm and 0.41 mm respectively. As per IS Code, the solid classification will be

- a. SW  
b. SP  
c. SM  
d. SC

19. The plasticity index and the percentage of grain size finer than 2 microns of a clay sample are 25 and 15, respectively. Its activity ratio is

- a. 2.5  
b. 1.67  
c. 1.0  
d. 0.6

20. A soil sample having a void ratio of 1.3, water content of 50% and a specific gravity of 2.60, is in a state of

- a. partial saturation  
b. full saturation  
c. oversaturation  
d. undersaturation

21. The natural void ratio of a san sample is 0.6 and its density index is 0.6. If its void ratio in the loosest state is 0.9, then the void ratio in the densest state will be

- a.

- b. 0.3  
c. 0.4  
d. 0.5

22. The following data were obtained when a sample of medium sand was tested in a constant heat permeameter :

Cross-section area of sample :  $100 \text{ cm}^2$

Hydraulic gradient : 10

Discharge collected : 10cc/s

The coefficient of permeability of the sand is

- a. 0.1 m/s  
b. 0.01 m/s  
c.  $1 \times 10^{-4}$  m/s  
d.  $1 \times 10^{-8}$  s m/s

23. Match List I (Test) with List II(Property) and select the correct answer :

**List I**

- A. Proctor Test  
B. Vane Test  
C. Penetration Test  
D. Hydrometer Test

**List II**

1. Grain Size Analysis  
2. Shear strength  
3. Bearing Capacity  
4. Compaction

	A	B	C	D
a.	2	4	1	3
b.	4	3	1	3
c.	4	2	3	1
d.	2	4	3	1

24. Which one of the following phase diagrams represents a clay at its shrinkage limit ?

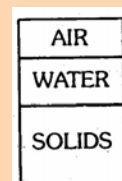

- a.

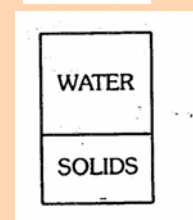

- b.

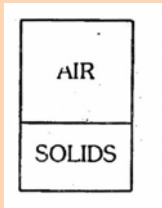

c.

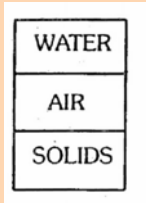

d.

25. Which one of the following correctly represents the dry unit weight of a soil sample which has a bulk unit weight  $\gamma_t$  of at a moisture content of  $\omega\%$  ?

- a.  $\frac{\omega\gamma_t}{100}$   
 b.  $\gamma_t \left(1 + \frac{\omega}{100}\right)$   
 c.  $\gamma_t \left(\frac{100}{100 + \omega}\right)$   
 d.  $\frac{\gamma_t(100 - \omega)}{100}$

26.

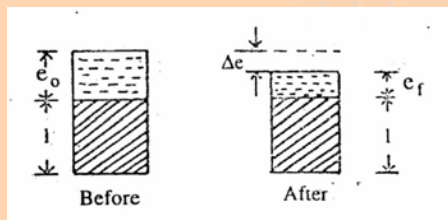

The figure given above shown the state of a sample of clay before and after consolidation. Based on these figures, the settlement of a clay layer of initial thickness H will be

- a.  $\frac{\Delta e}{(1 + e_0)}$   
 b.  $\frac{H\Delta e}{(1 + e_f)}$   
 c.  $\frac{\Delta e}{(1 + e_f)}$   
 d.  $\frac{H\Delta e}{(1 + e_0)}$

27. A soil sample test in a triaxial compression apparatus failed when the total maximum

and minimum principal stresses were 100 kPa and 40 kPa, respectively. The pore pressure measured at failure was 10 kPa. The effective principal stress ratio at failure is

- a. 2.5  
 b. 3.0  
 c. 2.75  
 d. 2.0

28. An earth-retaining structure may be subjected to the following lateral earth pressures :

1. Earth pressure at rest
2. passive earth pressure
3. Active earth pressure

The correct sequence of the increasing order of the magnitude of these pressure is

- a. 3, 2, 1  
 b. 1, 3, 2  
 c. 1, 2, 3  
 d. 3, 1, 2

29. For a sand having an internal friction of  $30^\circ$ , the ratio of passive to active lateral earth pressure will be

- a. 1  
 b. 3  
 c. 6  
 d. 9

30. The total, neutral and effective vertical stresses (in  $t/m^2$ ) at a depth of 5m below the surface of a fully saturated soil deposit with a saturated density of  $2 t/m^3$  would, respectively, be

- a. 5, 5 and 10  
 b. 5, 10 and 5  
 c. 10, 5 and 10  
 d. 10, 5 and 5

31.

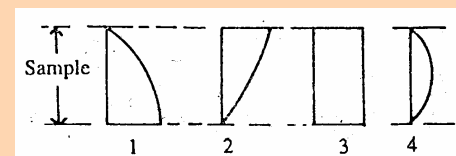

Excess pore pressure distribution within the thickness of a soil sample tested in oedometry sometime after loading is shown in the above figures labeled 1, 2, 3 and 4. Which one of these figures, refers to a situation where the operator forgot to put

on the porous stones at the top and bottom of the sample before the test ?

- 1
- 2
- 3
- 4

32. In soil consolidation process, the following events take place after loading :

1. Decrease in excess pore pressure
2. Increase in total stress
3. Development of excess pore pressure
4. Increase in effective stress.

The correct sequence of these events is:

- 3, 2, 1, 4
- 2, 3 1, 4
- 2, 3, 4, 1
- 3, 2, 4, 1

33.

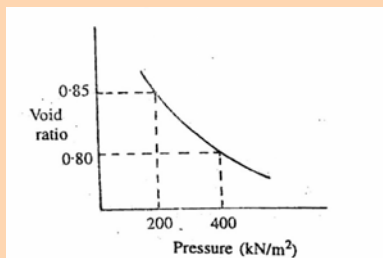

The e-p curve for a soil is shown in the above figure. The coefficient of compressibility (in m<sup>2</sup>/kN) of the soil is

- 4000
- 2000
- $2.5 \times 10^{-4}$
- $1.25 \times 10^{-4}$

34. A saturated clay layer with double drainage takes 5 years to attain 90% degree of consolidation under a structure. If the same layer were to be single drained, what would be the time (in years) required to attain the same consolidation under the same loading conditions ?

- 10
- 15
- 20
- 25

35. In the Engineering News Record formula for determining the safe load carrying capacity of a pile, the factor of safety used is

- 2.5

- 3
- 4
- 6

36. Two circular footings of diameters  $D_1$  and  $D_2$  are resting on the surface of a purely cohesive soil. The ratio  $D_1/D_2 = 2$ . If the ultimate load carrying capacity of the footing of diameter  $D_1$  is 200 kN/m<sup>2</sup>, then the ultimate bearing capacity (in kN/m<sup>2</sup>) of the footing of diameter  $D_2$  will be

- 100
- 200
- 314
- 571

37. The minimum bearing capacity of a soil under a given footing occurs when the groundwater table at the location is at

- the base of the footing
- the ground level
- a depth equal to one-half of the width of footing
- A depth equal to the width of footing

38. In a Newmark's influence chart for stress distribution, there are 10 concentric circles and 50 radial lines. The influence factor of the chart is

- 0.0002
- 0.002
- 0.02
- 0.2

39. In the case of a pile foundation, negative skin friction may occur at a load which is

- lower than the designed load
- higher than the designed load
- equal to the designed load
- of any magnitude

40. In under-reamed pile construction, the ratio of shaft diameter to bulb diameter is

- 1/1.5
- 1/2
- 1/2.5
- 1/4

41. Match List I (Field test) with List II (Property) and select the correct answer :

**List I**

- Pumping test
- Plate load test

C. Pile load test

**List II**

1. Bearing capacity
2. Load carrying capacity
3. Permeability

	A	B	C
a.	1	2	3
b.	3	1	2
c.	2	3	1
d.	3	2	1

42. Match List I (Distress) with List II(meaning) and select the correct answer :

**List I**

- A. Settlement
- B. Subsidence
- C. Depression
- D. Distortion

**List II**

1. A localized, rather abrupt lowering of the road surface
2. A general lowering of the road surface
3. Irregular deformation of the road
4. Dished localized deformations

	A	B	C	D
a.	2	1	4	3
b.	1	2	4	3
c.	2	1	3	4
d.	1	2	3	4

43. Consider the following stages in the construction of concrete roads :

1. Preparing the subgrade and the base course.
2. Mixing and placing the concrete.
3. Placing the framework and water the prepared base
4. Curing
5. Compaction and floating .

The correct sequence of these stages is

- a. 1, 2, 3, 4, 5
- b. 1, 3, 2, 5, 4
- c. 1, 2, 3, 5, 4
- d. 1, 3, 2, 4, 5

44. Given that

coefficient of curvature = 1.4,

$$D_{30} = 3 \text{ mm,}$$

$$D_{10} = 0.6 \text{ mm}$$

Based on this formation on particle size distribution for use as subgrade, this will be taken to be

- a. uniformly-graded sand
- b. well-graded sand
- c. very fine sand
- d. poorly-graded sand

45. Consider the following statements regarding soil stabilization :

1. Subgrade should be treated if it has a soaked CBR of 5 or less.
2. Sub-bases, after treatment, should have plasticity index not less than 5.
3. Base courses after treatment should have plasticity index of not more than 2 and a CBR in excess of 100.

Which of these statements(s) is/are correct?

- a. 1, 2 and 3
- b. 1 and 3
- c. 2 and 3
- d. 1 alone

46. While driving at a speed of 30 kmph (with available friction 0.4) down the grade, the driver requires a braking distance twice the required for stopping the vehicle when he travels up the same grade. The grade is

- a. 7%
- b. 10.6%
- c. 13.3%
- d. 33.3%

47. Modulus of subgrade reaction using 30 cm diameter plate is obtained as  $200 \text{ N/cm}^3$ . The value of the same (in  $\text{N/cm}^3$ ) using the standard plate will be

- a. 500
- b. 200
- c. 85
- d. 80

48. An observer travelling at a constant speed of 70 kmph with the traffic stream over a 5 km stretch is passed by 17 vehicles more than what he passes. When the observer travels against the stream at the same speed, the number of vehicles he meets is 303. the flow of the traffic stream is

- a. 4480 vph
- b. 4160 vph

- c. 2240 vph  
d. 2002 vph
49. If the total seven-day traffic volume for the week is 3625 and the traffic volume for Monday is 650, then the monthly expansion factor for Monday is would be
- 5.6
  - 1.25
  - 0.8
  - 0.25
50. Which one of the following is the purpose of divisional island ?
- To divert the traffic into definite travel path at the inter-section.
  - To reduce the speed of traffic entering the intersection
  - To divert traffic from obstacles and expedite the flow of traffic
  - To segregate opposing flow of traffic in a multi-lane high-way
51. Tunnel alignment is carried out y
- surface theodolite traverse
  - triangulation
  - compass traverse
  - aerial photography
52. With reference to tunneling, which of the following factors are to be considered for deciding the size to the shaft ?
- system used for hoisting
  - size of the muck car.
  - Quantity of muck to be lifted.
  - Eventual use of the shaft.
- Select the correct answer using the codes given below :
- 1, 2 and 3
  - 1 and 4
  - 2, 3 and 4
  - 1, 2, 3 and 4
53. Which one of the following is installed as the second signal on the main signal post for better visibility ?
- Routing signal
  - Calling on signal
  - Co-acting signal
  - Repeating signal
54. Squaring of sleepers through packing consists of
- adjusting the sleepers to be perpendicular to the rails
  - adjusting the ballast under sleepers to space them parallel to each other
  - cutting the edges of the sleepers to a square shape
  - adjusting the rails to be perpendicular to the sleepers
55. In deep water waves, individual particles
- are translated
  - are translated and rotated in a vertical plate about a horizontal axis
  - are not translate, but they rotate in a vertical plate about a horizontal axis
  - do not rotate in a vertical plate about a horizontal axis.
56. A surface longitudinally centered on the extended runway centre lie and extending outward and upward is called
- primary surface
  - conical surface
  - horizontal surface
  - approach surface
57. Which of the following factors are to be taken into consideration while designing the taxiway system ?
- Volume of air traffic.
  - Runway configuration.
  - Location of terminal building
  - Location of hangars.
- Select the correct answer using the codes given below :
- 1, 2 and 3
  - 2 and 3
  - 1 and 4
  - 1, 2, 3 and 4
- 58.

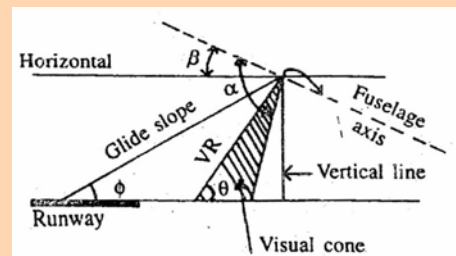

In the above figure shown, “cockpit cutoff angle” is the angle labelled

- $\alpha$
- $\beta$

- c.  $\phi$   
d.  $\theta$
59. Which of the following Pairs are correctly matched ?
1. Telemeter : Measurement of distance
  2. Price meter : Measurement of difference in elevation between points
  3. Sounding sextant : Measurement of horizontal angles
  4. Clinometer : Measurement of vertical angles
- Select the correct answer using the code given below :
- a. 2, 3 and 4
  - b. 1, 3 and 4
  - c. 1, 2 and 4
  - d. 1, 2 and 3
60. Consider the following steps :
1. Calculation of  $\sum L$  and  $\sum D$
  2. Correction of latitudes and departures.
  3. Calculation of bearings.
  4. Calculation of interior angles.
  5. Calculation of independent angles.
- The correct sequence of these steps in Gale's transverse table calculations is
- a. 3, 4, 5, 2, 1
  - b. 4, 3, 1, 2, 5
  - c. 2, 1, 3, 4, 5
  - d. 4, 3, 5, 2, 1
61. A tower appears in two successive photographs taken at an altitude of 4000 m above datum. The focal length of the camera is 160 mm. The length of the air base is 300 m. The parallax for the top and bottom of the pole are 72 mm and 63 mm respectively. The height of the top of the tower above its bottom is nearly
- a. 63 mm
  - b. 72 mm
  - c. 95 mm
  - d. 135 mm
62. A road section of length 1 km scales 8 cm on a vertical photograph. The focal length of the camera is 160 mm. If the terrain is fairly level, then the flying height will be
- a. 20 m
  - b. 2000 m
  - c. 20 km
  - d. 200 km
63. The sensitiveness of a bubble tube in a level would decrease if
- a. The radius of the curvature of the internal surface of the tube is increased
  - b. The diameter of the tube is increased
  - c. The length of the vapour bubble is increased
  - d. The viscosity of the liquid is increased
64. In a closed traverse with five sided, the error found from the fore bearing and back bearing of the last line is  $+2^\circ$ . The correction to the third line will be
- a.  $0^\circ 24'$
  - b.  $0^\circ 48'$
  - c.  $1^\circ 12'$
  - d.  $1^\circ 36'$
65. At a given place of observation, the declination of a circumpolar star is
- a. greater than the latitude
  - b. equal to the latitude
  - c. less than the co-latitude
  - d. greater than the co-latitude
66. Theory of errors and adjustments deals with minimizing the effects of
- a. instrumental errors
  - b. mistakes
  - c. systematic errors
  - d. personal and accidental errors
67. Assertion (A) : The available yield of a tubewell can be doubled by doubling the diameter of the well.  
Reason (R) : The yield of a tubewell varies inversely with the logarithm of the reciprocal of the diameter of the well.
- a. Both A and R are true and R is the correct explanation of A
  - b. Both A and R are true but R is NOT the correct explanation of A
  - c. A is true but R is false
  - d. A is false but R is true
68. Assertion (A) : Total drag is reduced if the boundary layer on the surface of a cylinder separated further downstream of the leading point.



Reason (R) : As the separation point moves further downstream, form drag is reduced and the skin drag is only marginally increased.

- Both A and R are true and R is the correct explanation of A
- Both A and R are true but R is NOT the correct explanation of A
- A is true but R is false
- A is false but R is true

69. Assertion (A) : Break-point chlorination is required to ensure free chlorine residuals for better disinfection.

Reason (R) : Free chlorine residuals have good disinfecting power and they are usually dissipated quickly in the distribution system.

- Both A and R are true and R is the correct explanation of A
- Both A and R are true but R is NOT the correct explanation of A
- A is true but R is false
- A is false but R is true

70. Assertion (A) : The design of all non-circular sections is based upon getting a “hydraulically equivalent section”.

Reason (R) : The chart of hydraulic elements is very useful in sewer design.

- Both A and R are true and R is the correct explanation of A
- Both A and R are true but R is NOT the correct explanation of A
- A is true but R is false
- A is false but R is true

71. Assertion (A) : black cotton soils are clays and they exhibit characteristic property of swelling.

Reason (R) : These clays contain montmorillonite which attracts external water into its lattice structure.

- Both A and R are true and R is the correct explanation of A
- Both A and R are true but R is NOT the correct explanation of A
- A is true but R is false
- A is false but R is true

72. Assertion (A) : The possibility of quicksand condition occurring is more on

the downstream of a weir on permeable foundation.

Reason (R) : Seepage lines are directed upwards at the downstream of such a weir.

- Both A and R are true and R is the correct explanation of A
- Both A and R are true but R is NOT the correct explanation of A
- A is true but R is false
- A is false but R is true

73. Assertion (A) : Effective vertical stress at some depth below a river bed is unaffected by the water depth in the river

Reason (R) : Equal amounts of increase in total stress and pore pressure will not change the effective stress.

- Both A and R are true and R is the correct explanation of A
- Both A and R are true but R is NOT the correct explanation of A
- A is true but R is false
- A is false but R is true

74. Assertion (A) : Permanent lowering of GWT result in settlements.

Reason (R) : Increase in effective stress results in settlement in soils.

- Both A and R are true and R is the correct explanation of A
- Both A and R are true but R is NOT the correct explanation of A
- A is true but R is false
- A is false but R is true

75. Assertion (A) : When a sharp horizontal curve is to be introduced on a road which already had the maximum permissible gradient, the gradient should be decreased.

Reason (R) : The gradient should be decreased to compensate for the loss of tractive effort due to the introduction of sharp horizontal curve on the road.

- Both A and R are true and R is the correct explanation of A
- Both A and R are true but R is NOT the correct explanation of A
- A is true but R is false
- A is false but R is true

76. Assertion (A) : The most common approach or control of beach erosion is to build groynes.

Reason (R) : Groynes are constructed parallel to the shore.

- Both A and R are true and R is the correct explanation of A
- Both A and R are true but R is NOT the correct explanation of A
- A is true but R is false
- A is false but R is true

77. Assertion (A) : Gradients much steeper than the ruling gradient are provide in a hilly terrain and they are negotiated with the help of a pusher engine.

Reason (R) : Restricting the gradient to the ruling gradient in hilly terrains would mean increasing the length of the track resulting considerably in heavy excavation.

- Both A and R are true and R is the correct explanation of A
- Both A and R are true but R is NOT the correct explanation of A
- A is true but R is false
- A is false but R is true

78. Assertion (A) : Whole circle bearing of a line is preferred to a quadrantal bearing.

Reason (R) : Bearing is completely specified by an angle.

- Both A and R are true and R is the correct explanation of A
- Both A and R are true but R is NOT the correct explanation of A
- A is true but R is false
- A is false but R is true

79. Assertion (A) : the centrifugal ratio decreases along the length of the transition curve.

Reason (R) : The superelevation increases along the length of the transition curve.

- Both A and R are true and R is the correct explanation of A
- Both A and R are true but R is NOT the correct explanation of A
- A is true but R is false
- A is false but R is true

80. Which of the following air pollutants are responsible for the green house effect ?

- Methane
- Carbon dioxide
- Flurocarbons

4. Nitrogen oxides

Select the correct answer using the codes given below :

- 2 and 3
- 1 and 2
- 1, 3 and 4
- 1, 2, 3 and 4

81. A soil sampler has inner and outer radii of 25 mm and 30 mm respectively. The area ratio of the sampler is

- 24%
- 34%
- 44%
- 54%

82. Match List I with List II and select the correct answer :

**List I**

- Concentrated sugar solution
- Sewage sludge
- Blood
- Air

**List II**

- Dilatant Fluid
- Bingham plastic fluid
- Pseudoplastic fluid
- Newtonia fluid.

	A	B	C	D
a.	1	2	3	4
b.	1	2	4	3
c.	2	1	3	4
d.	2	1	4	3

83. A metal cube of size 15 cm × 15 cm × 15 cm and specific gravity 8.6 is submerged in a two-layered liquid, the bottom layer being mercury and the top layer being water. The percentage of the volume of the cube remaining above the interface will be, approximately

- 68
- 63
- 40
- 25

84. A 30 cm diameter, 90° elbow has one limb vertical. Average velocity of flow of water through the elbow is 5 m/s and the pressure intensity is 4 kPa. The vertical

- component of force to keep the elbow in position will be
- 0.28 kN
  - 1.49 kN
  - 1.77 kN
  - 2.05 kN
85. Which one of the following statements relating to Vortex Flow is INCORRECT?
- In the formation of a free vortex, streamlines are axisymmetric and irrotational
  - In a forced vortex, work transfer between the fluid and the surroundings takes place and the flow is rotational
  - In a free vortex, radial motion towards the core takes place due to variation of depth of water in the whirlpool or due to the difference of pressure resulting from higher velocity near the core
  - In a free vortex, there is not variation of energy from streamline to streamline and irrotationality is not deviated from near the core
86. Consider the following measuring structures :
- submerged broad-crested weir
  - Free broad-crested weir.
  - Free sharp-crested weir.
  - Free ogee spillway.
- The correct sequence of the increasing order of the discharge coefficient of these structures is
- 1, 2, 4, 3
  - 2, 1, 3, 4
  - 2, 1, 4, 3
  - 1, 2, 3, 4
87. In a laminar flow between two static parallel plates, the velocity at mid-point is found to be 2.0 m/s. If the space between the plates is 10 cm, then the discharge per unit width (in  $\text{m}^3/\text{s}/\text{m}$ ) will be
- 0.01
  - 0.02
  - 0.10
  - 0.20
88. A fluid with kinematic viscosity  $\nu$  flows in laminar stage along a flat plate with free-stream velocity  $V$ . At a distance  $x$  from the leading edge, the Reynolds number of the flow is given by  $R = Vx/\nu$ . The thickness of the boundary layer at  $x$  will be proportional to
- $xR^{1/2}$
  - $xR^{-1/2}$
  - $R^{1/2}$
  - $R^{-1/2}$
89. Magnus effect may be used advantageously in games such as cricket, tennis, table tennis and golf. In order to obtain a lift, i.e. a rising curve for the trajectory of the ball, from left to right, the nature of the spin to be given is
- anticlockwise in the vertical plane
  - anticlockwise in the horizontal plane
  - clockwise in the vertical plane
  - clockwise in the horizontal plane
90. Two tanks are connected in parallel by two pipes A and B of identical friction factors and lengths. If the size of pipe A is double that of pipe B, then their discharges will be in the ratio of
- 2
  - 4
  - 5.66
  - 32
91. Water of  $\nu = 1$  centistoke flows through a 1 cm diameter pipe. Critical flow will correspond to a discharge of approximately
- 0.008 l/s
  - 0.013 l/s
  - 0.016 l/s
  - 0.025 l/s
92. Match List I (Surface) with List II (Approximate range of Manning's  $n$ ) and select the correct answer :
- List I**
- Gravel river bed with 50 mm diameter bed
  - Badly maintained unlined irrigation channel with weed growth
  - Concrete lined channel
  - Channel with brick lining
- List II**
- 0.02 to 0.022
  - 0.025 to 0.04
  - 0.013 to 0.017

4. 0.04 to 0.08

	A	B	C	D
a.	4	3	2	1
b.	4	2	3	1
c.	1	3	2	4
d.	1	2	3	4

93. Water surface profiles that are asymptotic at one end and terminated at the other and would include

- $H_2$  and  $S_2$
- $H_3$  and  $S_2$
- $M_2$  and  $H_2$
- $M_2$  and  $H_3$

94. A hydraulic jump is always needed in case of

- an  $A_2$  profile followed by an  $A_3$  profile
- an  $A_3$  profile followed by an  $M_2$  profile
- an  $H_2$  profile followed by an  $M_2$  profile
- and  $M_1$  profile followed by an  $M_3$  profile

95. Which of the following principles relate to a unit Hydrograph ?

- The hydrographs of direct run off due to effective rainfall of equal duration have the same time base.
- Effective rainfall is not uniformly distributed within its duration.
- Effective rainfall is uniformly distributed throughout the whole area of drainage basin.
- Hydrograph of direct run off from a basin due to a given period of-effective rainfall reflects the combination of all the physical characteristics of the basin.

Select the correct answer using the codes given below :

- 1, 2 and 3
- 1, 2 and 4
- 2, 3 and 4
- 1, 3 and 4

96. Match list I with list II and select the correct answer :

**List I**

- Anemometer
- Rain simulator
- Lysimeter

D. Hygrometer

**List II**

- Humidity
- Evapotranspiration
- Infiltration
- Wind speed

	A	B	C	D
a.	4	3	1	2
b.	3	4	1	2
c.	4	3	2	1
d.	3	4	2	1

97. The life of reservoir is determined by its capacity (C), volume of annual inflow into the reservoir (I) and concentration of sediment in the incoming flow ( $C_s$ ). Life will be more if

It has

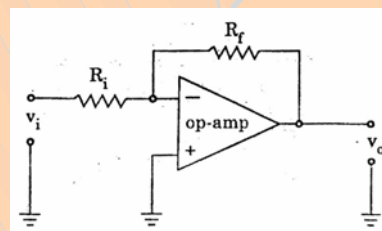

- voltage series feedback
- voltage shunt feedback
- current shunt feedback
- current series feedback

98. The IF amplifier in a superheterodyne receiver is

- single-stage single-tuned amplifier
- two stages of single-tuned amplifier
- double-tuned amplifier
- Class-C amplifier

99. RC network shown in the given figure can provide a maximum theoretical phase shift of

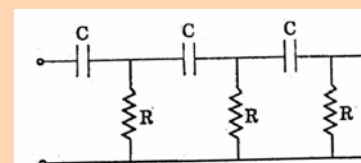

- $90^\circ$
- $180^\circ$
- $270^\circ$
- $360^\circ$

100. Which one of the following circuits is most suitable as an oscillator at a frequency of 100 Hz ?

- a. Hartley oscillator
- b. Colpitts oscillator
- c. Crystal oscillator
- d. Twin-T oscillator

101. A circuit is showing the given figure. The largest value of  $R_L$  that can be used, is

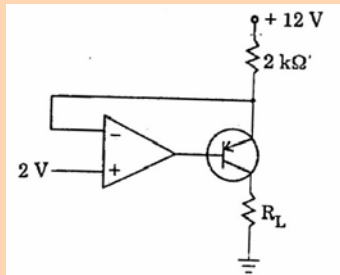

- a.  $100 \Omega$
  - b.  $400 \Omega$
  - c.  $2 \text{ k}\Omega$
  - d.  $20 \text{ k}\Omega$
102. A differential amplifier is invariably used in the input stage of all op-amps. This is done basically to provide the opamps with a very high
- a. CMRR
  - b. bandwidth
  - c. slew rate
  - d. open-loop gain
103. In the circuit shown in the given figure, the current  $I$  through the resistance  $R$  is

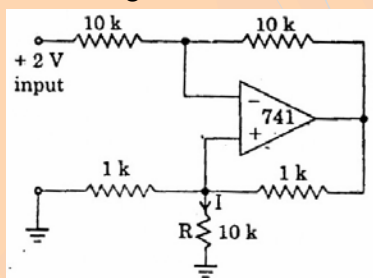

- a.  $100 \mu\text{A}$
  - b.  $-100 \mu\text{A}$
  - c.  $1 \text{ mA}$
  - d.  $-1 \text{ mA}$
104. The effect of a finite gain of an operational amplifier used in an integrator is that
- a. it would not integrate
  - b. the slope of the output will vary with time
  - c. the final value of the output voltage will reduce
  - d. there will be instability in the circuit

105. In a PLL, lock occurs when the
- a. input frequency and the VCO frequency are the same
  - b. phase error is  $180^\circ$
  - c. VCO frequency is double the input frequency
  - d. None of these

106.

Item	Canal data	Drainage data
Flow( $\text{m}^3/\text{s}$ )	5	500
Bed level(m)	120	116
Depth of flow (m)	0.8	10

Which one of the following types of cross-drainage should be recommended in this case ?

- a. Aqueduct
- b. Syphon aqueduct
- c. Syphon
- d. Superpassage

107. Consider the following statements :

The down stream impervious flow of concrete for a barrage has ruptured. This can be due to

1. insufficient length of upstream impervious floor.
2. insufficient length of downstream impervious floor.
3. insufficient depth of downstream pile.
4. choking of inverted filter.

Which of these statements are correct ?

- a. 1 and 2
- b. 1 and 4
- c. 2, 3 and 4
- d. 1, 2, 3 and 4

108. Ten  $\text{m}^3/\text{s}$  of water is diverted to a 32 hectare field for 4 hours. Soil proving after irrigation showed that 0.3 m of water had been stored in the root zone. Water application efficiency in this case would be

- a. 96%
- b. 66.67%
- c. 48%
- d. 24%

109. Which one of the following statements is correct ?

In a river, silt excluder and silt ejector are constructed

- at a location after the head regulator and at the head of the canal, respectively
- at the head of the canal and at a location after the head regulator, respectively
- at the same location
- at specific locations depending upon diverse factors and their locations do not follow a set pattern

110. The ideal efficiency of a single-jet Pelton wheel is given by

$$2/V^2 [Vv + v(V-v)\cos\phi - v^2]$$

(symbols have their usual meanings)

If friction on the buckets reduces the relative velocity by a factor  $k_1$  and if windage losses reduce the effectiveness of the affected parameters by a factor  $k_2$ , then the resulting efficiency multiplied by  $V^2$  is given by

- $2k_1k_2 [Vv + v(V-v)\cos\phi - v^2]$
- $2[k_2Vv + k_2v(V-v)\cos\phi - v^2]$
- $2[k_2Vv + k_1k_2v(V-v)\cos\phi - v^2]$
- $2[k_2Vv + k_1k_2v(V-v)\cos\phi - k_2v^2]$

111. Match list I (Units in water treatment plant) with list II (Impurities removed) and select the correct answer :

**List I**

- Aerator
- Rapid sand filter
- Slow sand filter
- Sedimentation tank(after coagulation and flocculation)

**List II**

- Excess  $CO_2$  and  $H_2S$
- Settleable and colloidal matter
- suspended matter
- suspended matter
- suspended, colloidal and bacteriological matter

	A	B	C	D
a.	1	3	2	4
b.	3	1	2	4
c.	3	1	4	2
d.	1	3	4	2

112. Which of the following statements are correct ?

- Groundwater is generally free from suspended and dissolved impurities
- Suspended matters often contain pathogenic bacteria
- rain water is soft and tasteless
- Lake water may contain microscopic organisms.

Select the correct answer using the codes given below :

- 1, 2, 3 and 4
- 1 and 2

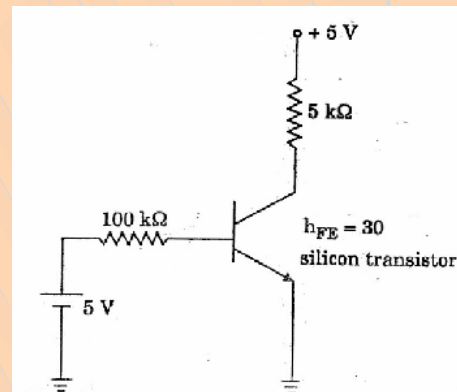

- in the active region
- in the saturation region
- in the saturation region
- either in the active or the saturation region.

113. Which of the following regions of operation are mainly responsible for heating of the transistor under switching operation ?

- Saturation region.
- cut-off region.
- Transition from saturation to cut-off.
- Transition from cut-off to saturation.

Select the correct answer using the codes given below :

- 1 and 2
- 2 and 3
- 3 and 4
- 1 and 3

114. The circuit shown in the given figure

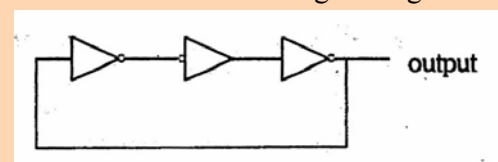

- a. is an oscillating circuit and its output is a square wave
- b. is an whose output remains stable in '1' state
- c. is one whose output remains stable in '0' state
- d. gives a single pulse of 3 times propagation delay

115. The circuit of a gate in the resistor transistor logic (RTL) family shown in the given figure is a/an

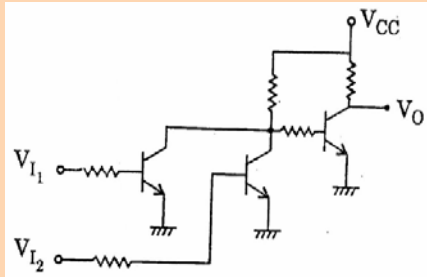

- a. AND gate
  - b. OR gate
  - c. NAND gate
  - d. NOR gate
116. The decoding error of the counter can be avoided by
- a. increasing propagation delay of flip-flops used in the counter
  - b. using very fast logic gates
  - c. using the strobe signal
  - d. reducing the propagation delay of flip-flops used in the counter
117. Which one of the following flags is not used for branching in a microprocessor ?
- a. Carry flag
  - b. Auxiliary carry flag
  - c. Overflow flag
  - d. Parity flag
118. The number of comparator circuits required to build a three-bit simultaneous A/D converter is
- a. 7
  - b. 8
  - c. 15
  - d. 16

determination) and select the correct answer :

#### List I

A. Hardness

- B. Chlorine
- C. D.O.
- D. Chloride

#### List II

1. Wenker's method
2. EDTA method
3. Orthotolidine test
4. Mohr method

	A	B	C	D
a.	2	3	1	4
b.	2	4	1	3
c.	1	3	2	4
d.	1	4	2	3

119. The amount of bleaching power containing 20% available chlorine needed to chlorinate a rural water supply covering a population of 10000 at 50 lpcd at the rate of 2 ppm is

- a. 1 kg
- b. 5 kg
- c. 0.2 kg
- d. 20 kg

120. Which of the following statements(s) regarding industrial water supply is/are correct ?

1. Industrial water supplies need not be disinfected.
2. Water for industrial use requires chemical treatment.
3. Standards of purity and methods of treatment of water for industrial use are often different from those for domestic water supplies
4. It is more economical to use water from surface sources than from groundwater sources for industrial water supplies.

Select the correct answer using the codes given below :

- a. 1, 2 and 4
- b. 2, 3 and 4
- c. 3 and 4
- d. 3 only