

**Q. 1 – Q. 25 Carry One Mark Each.**

- The parabolic arc  $y = \sqrt{x}$ ,  $1 \leq x \leq 2$  is revolved around the  $x$ -axis. The volume of the solid of revolution is  
 (A)  $\pi/4$  (C)  $3\pi/4$   
 (B)  $\pi/2$  (D)  $3\pi/2$
- The Blasius equation,  $\frac{d^3 f}{d\eta^3} + \frac{f}{2} \frac{d^2 f}{d\eta^2} = 0$ , is a  
 (A) second order nonlinear ordinary differential equation  
 (B) third order nonlinear ordinary differential equation  
 (C) third order linear ordinary differential equation  
 (D) mixed order nonlinear ordinary differential equation
- The value of the integral  $\int_{-\infty}^{\infty} \frac{dx}{1+x^2}$  is  
 (A)  $-\pi$  (C)  $\pi/2$   
 (B)  $-\pi/2$  (D)  $\pi$
- The modulus of the complex number  $\left(\frac{3+4i}{1-2i}\right)$  is  
 (A) 5 (C)  $1/\sqrt{5}$   
 (B)  $\sqrt{5}$  (D)  $1/5$
- The function  $y = |2 - 3x|$   
 (A) is continuous  $\forall x \in \mathbb{R}$  and differentiable  $\forall x \in \mathbb{R}$   
 (B) is continuous  $\forall x \in \mathbb{R}$  and differentiable  $\forall x \in \mathbb{R}$  except at  $x = 3/2$   
 (C) is continuous  $\forall x \in \mathbb{R}$  and differentiable  $\forall x \in \mathbb{R}$  except at  $x = 2/3$   
 (D) is continuous  $\forall x \in \mathbb{R}$  except at  $x = 3$  and differentiable  $\forall x \in \mathbb{R}$
- Mobility of a statically indeterminate structure is  
 (A)  $\leq -1$  (C) 1  
 (B) 0 (D)  $\geq 2$
- There are two points P and Q on a planar rigid body. The relative velocity between the two points  
 (A) should always be along PQ  
 (B) can be oriented along any direction  
 (C) should always be perpendicular to PQ  
 (D) should be along QP when the body undergoes pure translation
- The state of plane stress at a point is given by  $\sigma_x$  200MPa,  $\sigma_y$  100 MPa and  $\tau_{xy}$  100MPa. The maximum shear stress (in MPa) is  
 (A) 111.8 (C) 180.3  
 (B) 150.1 (D) 223.6
- Which of the following statements is INCORRECT  
 (A) Grashof's rule states that for a planar crank – rocker four bar mechanism, the sum of the shortest and longest link lengths cannot be less than the sum of the remaining two link lengths.  
 (B) Inversions of a mechanism are created by fixing different links one at a time.  
 (C) Geneva mechanism is an intermittent motion device.  
 (D) Gruebler's criterion assumes mobility of a planar mechanism to be one.
- The natural frequency of a spring – mass system on earth is  $\omega_n$ . The natural frequency of this system on the moon ( $g_{\text{moon}} = g_{\text{earth}}/6$ ) is  
 (A)  $\omega_n$  (C)  $0.204 \omega_n$   
 (B)  $0.408 \omega_n$  (D)  $0.167 \omega_n$
- Tooth interference in an external involute spur gear pair can be reduced by  
 (A) decreasing center distance between gear pair  
 (B) decreasing module

- (C) decreasing pressure angle  
(D) increasing number of gear teeth
12. For the stability of a floating body, under the influence of gravity alone, which of the following is TRUE?  
(A) Metacentre should be below centre of gravity.  
(B) Metacentre should be above centre of gravity.  
(C) Metacentre and centre of gravity must lie on the same horizontal line.  
(D) Metacentre and centre of gravity must lie on the same vertical line.
13. The maximum velocity of a one – dimensional incompressible fully developed viscous flow, between two fixed parallel plates, is  $6 \text{ ms}^{-1}$ . The mean velocity ( in  $\text{ms}^{-1}$ ) of the flow is  
(A) 2 (C) 4  
(B) 3 (D) 5
14. A phenomenon is modeled using  $n$  dimensional variables with  $k$  primary dimensions. The number of non – dimensional variables is  
(A)  $k$  (C)  $n - k$   
(B)  $n$  (D)  $n + k$
15. A turbo – charged four – stroke direct injection diesel engine has a displacement volume of  $0.0259 \text{ m}^3$  (25.9 litres). The engine has an output of 950 kW at 2200 rpm. The mean effective pressure (in MPa) is closet to  
(A) 2 (C) 0.2  
(B) 1 (D) 0.1
16. One kilogram of water at room temperature is brought into contact with a high temperature thermal reservoir. The entropy change of the universe is  
(A) equal to entropy change of the reservoir  
(B) equal to entropy change of water  
(C) equal to zero  
(D) always positive
17. A hydraulic turbine develops 1000 kW power for a head of 40m. If the head is reduced to 20m, the power developed (in kW) is  
(A) 177 (C) 500  
(B) 354 (D) 707
18. The material property which depends only on the basic crystal structure is  
(A) fatigue strength (C) fracture strength  
(B) work hardening (D) elastic constant
19. In a gating system, the ratio 1: 2: 4 represents  
(A) sprue base area : runner area : ingate area  
(B) pouring basin area : ingate area : runner area  
(C) sprue base area : ingate area : casting area  
(D) runner area : ingate area : casting area
20. A shaft has a dimension,  $\text{Ø } 35^{-0.009}_{-0.025}$ . The respective values of fundamental deviation and tolerance are  
(A)  $-0.025, \pm 0.008$  (C)  $-0.009, \pm 0.008$   
(B)  $-0.025, 0.016$  (D)  $-0.009, 0.016$
21. In a CNC program block, N002 G02 G91 X40 Z40..., G02 and G91 refer to  
(A) circular interpolation in counterclockwise direction and incremental dimension  
(B) circular interpolation in counterclockwise direction and absolute dimension  
(C) circular interpolation in clockwise direction and incremental dimension  
(D) circular interpolation in clockwise direction and absolute dimension
22. The demand and forecast for February are 12000 and 10275, respectively. Using single exponential smoothing method (smoothing coefficient = 0.25), forecast for the month of March is  
(A) 431 (B) 9587

- (C) 10706 (D) 11000
23. Little's law is a relationship between  
 (A) stock level and lead time in an inventory system  
 (B) waiting time and length of the queue in a queuing system  
 (C) number of machines and job due dates in a scheduling problem  
 (D) uncertainty in the activity time and project completion time
24. Vehicle manufacturing assembly line is an example of  
 (A) product layout (C) manual layout  
 (B) process layout (D) fixed layout
25. Simplex method of solving linear programming problem uses  
 (A) all the points in the feasible region  
 (B) only the corner points of the feasible region  
 (C) intermediate points within the infeasible region  
 (D) only the interior points in the feasible region

**Q. 26 – Q. 55 Carry Two Marks Each**

**Note: All length dimensions shown in the figures are in mm (unless otherwise specified).**

**Figures are not drawn to scale.**

26. Torque exerted on a flywheel over a cycle is listed in the table. Flywheel energy (in J per unit cycle) using Simpson's rule is

Angle (degree)	0	60	120	180	240	300	360
Torque (N m)	0	1066	-323	0	323	-355	0

- (A) 542 (C) 1444  
 (B) 993 (D) 1986
27. One of the eigen vectors of the matrix  $A = \begin{bmatrix} 2 & 2 \\ 1 & 3 \end{bmatrix}$  is  
 (A)  $\begin{Bmatrix} 2 \\ -1 \end{Bmatrix}$  (C)  $\begin{Bmatrix} 4 \\ 1 \end{Bmatrix}$   
 (B)  $\begin{Bmatrix} 2 \\ 1 \end{Bmatrix}$  (D)  $\begin{Bmatrix} 1 \\ -1 \end{Bmatrix}$
28. Velocity vector of a flow field is given as  $\vec{V} = 2xy\hat{i} - x^2z\hat{j}$ . The vorticity vector at (1, 1, 1) is  
 (A)  $4\hat{i} - \hat{j}$  (C)  $\hat{i} - 4\hat{j}$   
 (B)  $4\hat{i} - \hat{k}$  (D)  $\hat{i} - 4\hat{k}$
29. The Laplace transform of a function  $f(t)$  is  $\frac{1}{s^2(s+1)}$ . The function  $f(t)$  is  
 (A)  $t - 1 + e^{-t}$  (C)  $-1 + e^{-t}$   
 (B)  $t + 1 + e^{-t}$  (D)  $2t + e^t$
30. A box contains 2 washers, 3 nuts and 4 bolts. Items are drawn from the box at random one at a time without replacement. The probability of drawing 2 washers first followed by 3 nuts and subsequently the 4 bolts is  
 (A) 2/315 (C) 1/1260  
 (B) 1/630 (D) 1/2520
31. A band brake having band – width of 80 mm, drum diameter of 250 mm, coefficient of friction of 0.25 and angle of wrap of 270 degrees is required to exert a friction torque of 1000 N m. The maximum tension (in kN) developed in the band is  
 (A) 1.88 (C) 6.12  
 (B) 3.56 (D) 11.56
32. A bracket (shown in figure) is rigidly mounted on wall using four rivets. Each rivet is 6 mm in diameter and has an effective length of 12 mm.

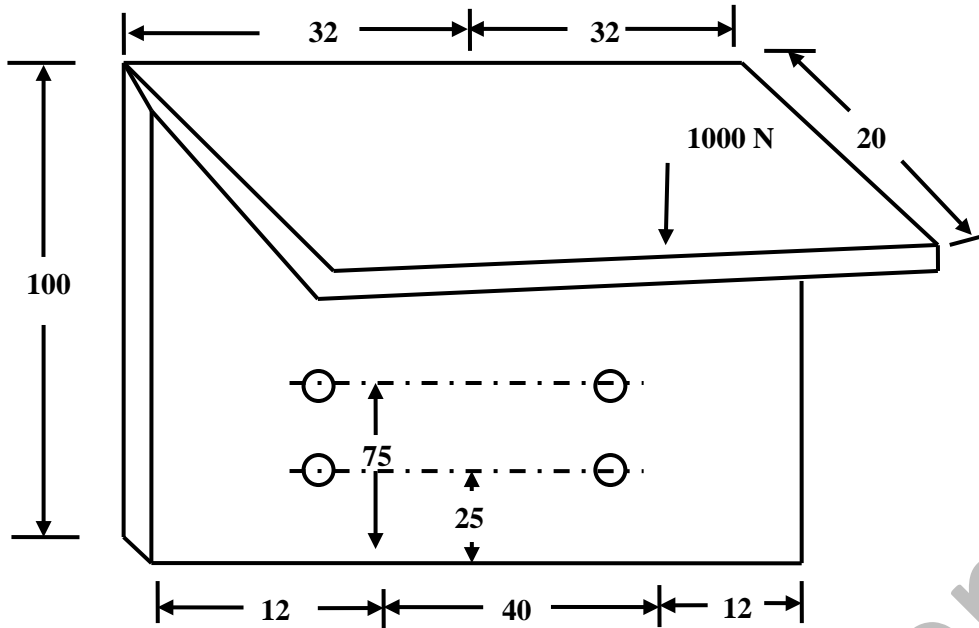

Direct shear stress (in MPa) in the most heavily loaded rivet is

- (A) 4.4 (C) 17.6  
(B) 8.8 (D) 35.2

33. A mass  $m$  attached to a spring is subjected to a harmonic force as shown in figure. The amplitude of the forced motion is observed to be 50 mm. The value of  $m$  (in kg) is

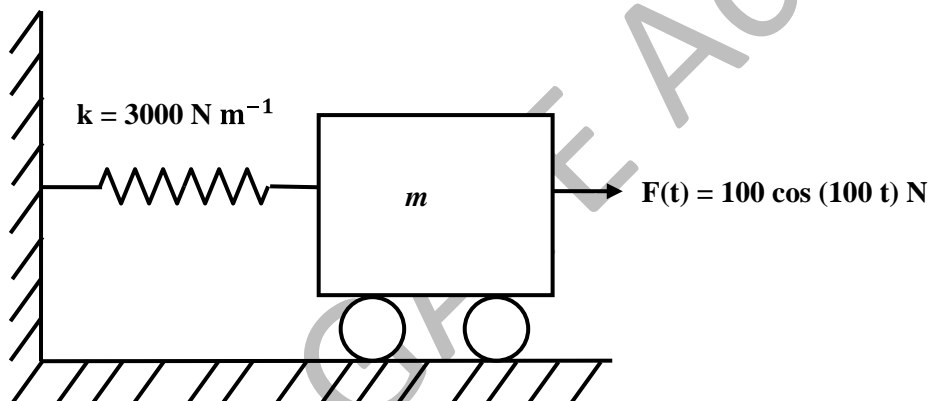

- (A) 0.1 (C) 0.3  
(B) 1.0 (D) 0.5

34. For the epicyclic gear arrangement shown in the figure,  $\omega_2 = 100$  rad/s clockwise (CW) and  $\omega_{arm} = 80$  rad/s counter clockwise (CCW). The angular velocity  $\omega_5$  (in rad/s) is

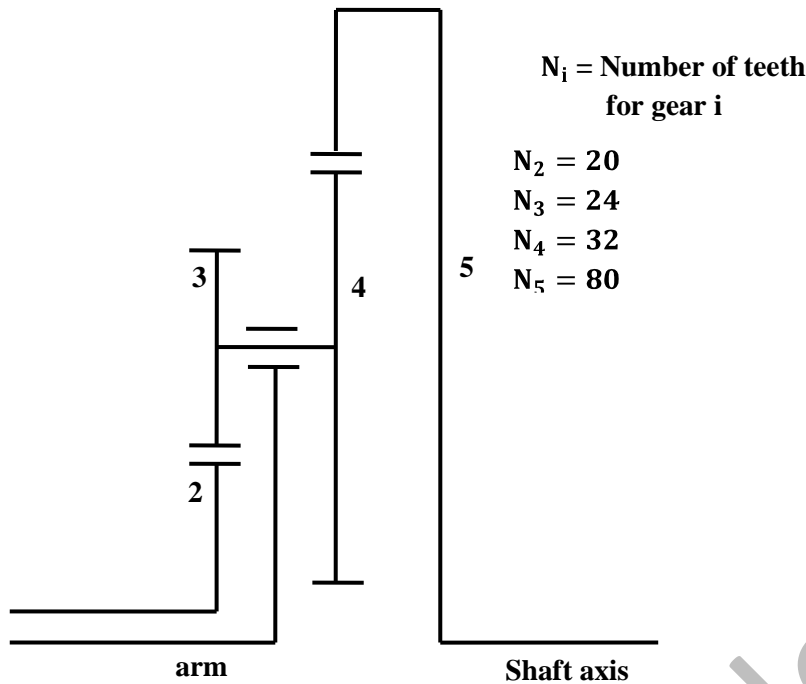

- (A) 0 (C) 140 CCW  
(B) 70 CW (D) 140 CW
35. A lightly loaded full journal bearing has journal diameter of 50 mm, bush bore of 50.05 mm and bush length of 20 mm. If rotational speed of journal is 1200 rpm and average viscosity of liquid lubricant is 0.03 Pa s, the power loss (in W) will be  
(A) 37 (C) 118  
(B) 74 (D) 237
36. For the configuration shown, the angular velocity of link AB is 10 rad/s counterclockwise. The magnitude of the relative sliding velocity (in  $\text{ms}^{-1}$ ) of slider B with respect to rigid link CD is

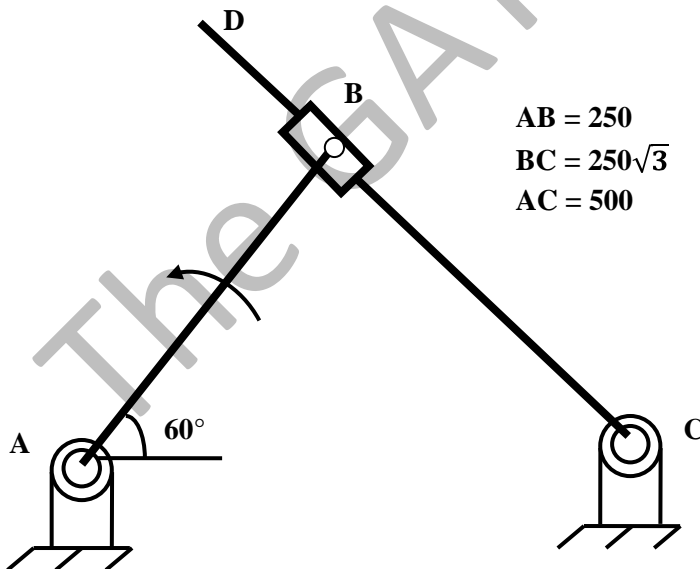

- (A) 0 (C) 1.25  
(B) 0.86 (D) 2.50
37. A smooth pipe of diameter 200 mm carries water. The pressure in the pipe at section S1 (elevation: 10m) is 50 kPa. At section S2 (elevation: 12m) the pressure is 20 kPa and velocity is  $2 \text{ ms}^{-1}$ . Density of water is  $1000 \text{ kgm}^{-3}$  and acceleration due to gravity is  $9.8 \text{ ms}^{-2}$ . Which of the following is TRUE  
(A) flow is from S1 to S2 and head loss is 0.53 m

- (B) flow is from S2 to S1 and head loss is 0.53 m  
 (C) flow is from S1 to S2 and head loss is 1.06 m  
 (D) flow is from S2 to S1 and head loss is 1.06m

38. Match the following

P: Compressible flow	U: Reynolds number
Q: Free surface flow	V: Nusselt number
R: Boundary layer flow	W: Weber number
S: Pipe flow	X: Froude number
R: Heat convection	Y: Mach number
	Z: Skin friction coefficient

- (A) P – U; Q – X; R – V; S – Z; T – W  
 (B) P – W; Q – X; R – Z; S – U; T – V  
 (C) P – Y; Q – W; R – Z; S – U; T – X  
 (D) P – Y; Q – W; R – Z; S – U; T – V
39. A mono – atomic ideal gas ( $\gamma = 1.67$ , molecular weight = 40) is compressed adiabatically from 0.1 MPa, 300 K to 0.2 MPa. The universal gas constant is  $8.314 \text{ kJ kmol}^{-1} \text{ K}^{-1}$ . The work of compression of the gas (in  $\text{kJ kg}^{-1}$ ) is  
 (A) 29.7  
 (B) 19.9  
 (C) 13.3  
 (D) 0
40. Consider the following two processes;  
 a. A heat source at 1200 K loses 2500 kJ of heat to a sink at 800 K  
 b. A heat source at 800 K loses 2000 kJ of heat to a sink at 500 K  
 Which of the following statements is true?  
 (A) Process I is more irreversible than Process II  
 (B) Process II is more irreversible than Process I  
 (C) Irreversibility associated in both the processes are equal  
 (D) Both the processes are reversible
41. A fin has 5 mm diameter and 100 mm length. The thermal conductivity of fin material is  $400 \text{ Wm}^{-1}\text{K}^{-1}$ . One end of the fin is maintained at  $130^\circ\text{C}$  and its remaining surface is exposed to ambient air at  $30^\circ\text{C}$ . If the convective heat transfer coefficient is  $40 \text{ Wm}^{-2}\text{K}^{-1}$ , the heat loss (in W) from the fin is  
 (A) 0.08  
 (B) 5.0  
 (C) 7.0  
 (D) 7.8
42. A moist air sample has dry bulb temperature of  $30^\circ\text{C}$  and specific humidity of 11.5 g water vapour per kg dry air. Assume molecular weight of air as 28.93. If the saturation vapour pressure of water at  $30^\circ\text{C}$  is 4.24 kPa and the total pressure is 90 kPa, then the relative humidity (in %) of air sample is  
 (A) 50.5  
 (B) 38.5  
 (C) 56.5  
 (D) 68.5
43. Two pipes of inner diameter 100 mm and outer diameter 110 mm each are joined by flash – butt welding using 30 V power supply. At the interface, 1 mm of material melts from each pipe which has a resistance of  $42.4 \Omega$ . If the unit melt energy is  $64.4 \text{ MJm}^{-3}$ , then time required for welding (in s) is  
 (A) 1  
 (B) 5  
 (C) 10  
 (D) 20
44. For tool A, Taylor's tool life exponent (n) is 0.45 and constant (K) is 90. Similarly for tool B,  $n = 0.3$  and  $K = 60$ . The cutting speed (in m/mm) above which tool A will have a higher tool life than tool B is  
 (A) 26.7  
 (B) 42.5  
 (C) 80.7  
 (D) 142.9
45. A taper hole is inspected using a CMM, with a probe of 2 mm diameter. At a height,  $Z = 10 \text{ mm}$  from the bottom, 5 points are touched and a diameter of circle (not compensated for probe size) is obtained as 20 mm. Similarly, a 40 mm diameter is obtained at a height  $Z = 40 \text{ mm}$ . The smaller diameter (in mm) of hole at  $Z = 0$  is

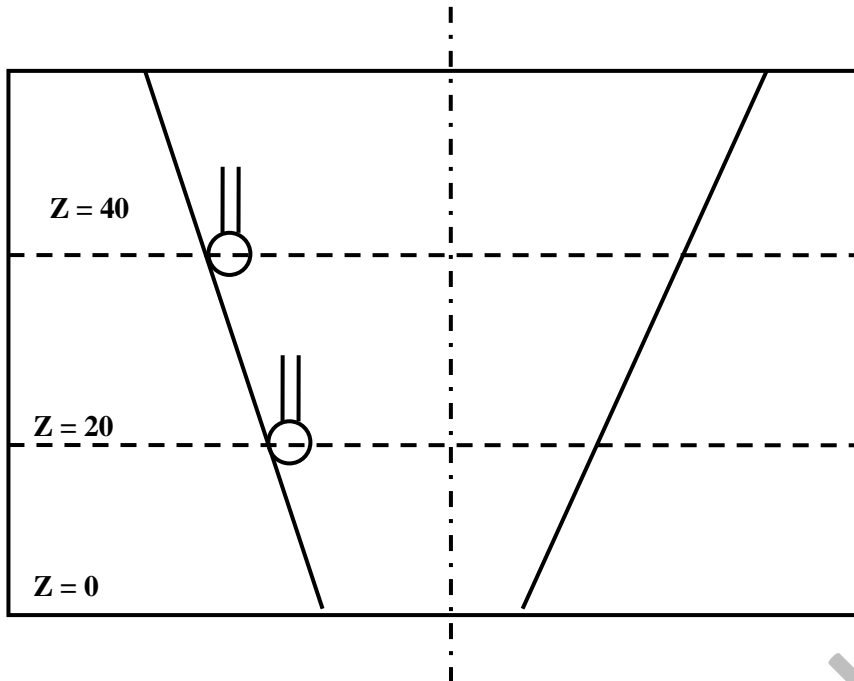

- (A) 13.334 (C) 15.442  
(B) 15.334 (D) 15.542
46. Annual demand for window frames is 10000. Each frame costs Rs. 200 and ordering cost is Rs. 300 per order. Inventory holding cost is Rs. 40 per frame per year. The supplier is willing to offer 2% discount if the order quantity is 1000 or more, and 4% if order quantity is 2000 or more. If the total cost is to be minimized, the retailer should
- (A) order 200 frames every time  
(B) accept 2% discount  
(C) accept 4% discount  
(D) order Economic Order Quantity
47. The project activities, precedence relationships and durations are described in the table. The critical path of the project is

Activity	Precedence	Duration (in days)
P	-	3
Q	-	4
R	P	5
S	Q	5
T	R,S	7
U	R,S	5
V	T	2
W	U	10

- (A) P – R – T – V (C) P – R – U – W  
(B) Q – S – T – V (D) Q – S – U – W

### Common Data Question

#### Common Data for Questions 48 and 49:

In a steam power plant operating on the Rankine cycle, steam enters the turbine at 4MPa, 350°C and exits at a pressure of 15 kPa. Then it enters the condenser and exits as saturated water. Next, a pump feeds back the water to the boiler. The adiabatic efficiency of the turbine is 90%. The thermodynamic states of water and steam are given in the table.

State	$h$ (kJ kg <sup>-1</sup> )	$s$ (kJ kg <sup>-1</sup> K <sup>-1</sup> )	$v$ (m <sup>3</sup> kg <sup>-1</sup> )
Steam: 4MPa, 350°C	3092.5	6.5821	0.06645

	$h_f$	$h_g$	$s_f$	$s_g$	$v_f$	$v_g$
Water: 15 kPa	225.94	2599.1	0.7549	8.0085	0.001014	10.02

$h$  is specific enthalpy,  $s$  is specific entropy and  $v$  the specific volume; subscripts  $f$  and  $g$  denote saturated liquid state and saturated vapour state.

48. The net work output ( $\text{kJ kg}^{-1}$ ) of the cycle is  
 (A) 498 (C) 860  
 (B) 775 (D) 957
49. Heat supplied ( $\text{kJ kg}^{-1}$ ) to the cycle is  
 (A) 2372 (C) 2863  
 (B) 2576 (D) 3092

**Common Data for Questions 50 and 51:**

Four jobs to be processed on a machine as per data listed in the table.

Job	Processing time (in days)	Due Date
1	4	6
2	7	9
3	2	19
4	8	17

50. If the Earliest Due Date (EDD) rule is used to sequence the jobs, the number of jobs delayed is  
 (A) 1 (C) 3  
 (B) 2 (D) 4
51. Using the Shortest Processing Time (SPT) rule, total tardiness is  
 (A) 0 (C) 6  
 (B) 2 (D) 8

**Linked Answer Questions**

**Statement for Linked Answer Questions 52 and 53:**

A massless beam has a loading pattern as shown in the figure. The beam is of rectangular cross – section with a width of 30 mm and height of 100mm

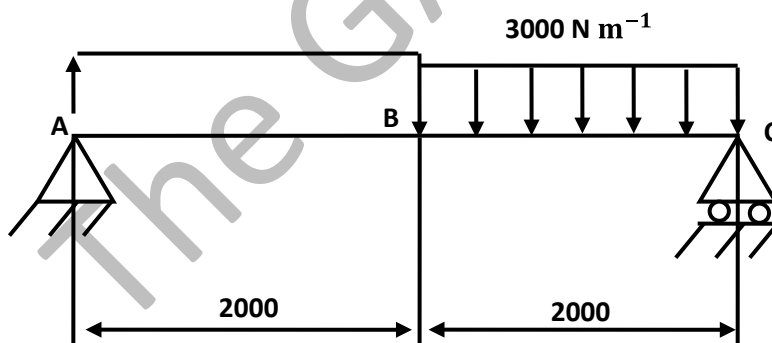

52. The maximum bending moment occurs at  
 (A) Location B (C) 2500 mm to the right of A  
 (B) 2675 mm to the right of A (D) 3225 mm to the right of A
53. The maximum magnitude of bending stress (in MPa) is given by  
 (A) 60.0 (C) 200.0  
 (B) 67.5 (D) 225.0



**Statement for Linked Answer Questions 54 and 55:**

In shear cutting operation, a sheet of 5 mm thickness is cut along a length of 200 mm. The cutting blade is 400 mm long (see figure) and zero – shear ( $S = 0$ ) is provided on the edge. The ultimate shear strength of the sheet is 100 MPa and penetration to thickness ratio is 0.2. Neglect friction.

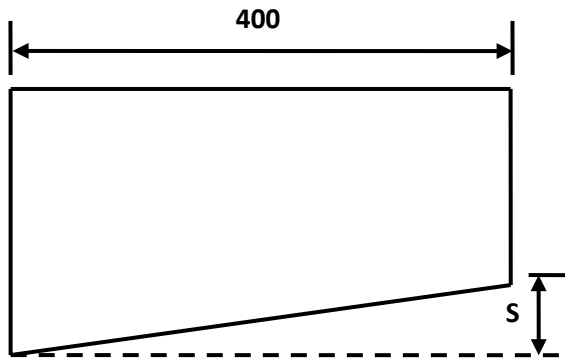

54. Assume force vs displacement curve to be rectangular, the work done (in J) is  
 (A) 100 (C) 250  
 (B) 200 (D) 300
55. A shear of 20 mm ( $S = 20$  mm) is now provided on the blade. Assuming force vs displacement curve to be trapezoidal, the maximum force (in kN) exerted is  
 (A) 5 (C) 20  
 (B) 10 (D) 40

**General Aptitude (GA) Question**

**Q. 56 – Q. 60 Carry One Mark Each.**

56. 25 persons are in a room. 15 of them play hockey, 17 of them play football and 10 of them play both hockey and football. Then the number of persons playing neither hockey nor football is:  
 (A) 2 (C) 13  
 (B) 17 (D) 3
57. Choose the most appropriate word from the options given below to complete the following sentence:  
 If we manage to \_\_\_\_\_ our natural resources, we would leave a better planet for our children.  
 (A) uphold (C) cherish  
 (B) restrain (D) conserve
58. The question below consists of a pair of related words followed by four pairs of words. Select the pair that best expresses the relation in the original pair.

**Unemployed : Worker**

- (A) fallow : land  
 (B) unaware : sleeper  
 (C) wit : jester  
 (D) renovated : house
59. Which of the following options is the closest in meaning to the word below:

**Circuitous**

- (A) cyclic  
 (B) indirect  
 (C) confusing  
 (D) crooked
60. Choose the most appropriate word from the options given below to complete the following sentence:

His rather casual remarks on politics \_\_\_\_\_ his lack of seriousness about the subject.

- (A) masked
- (B) belied
- (C) betrayed
- (D) suppressed

**Q. 61 – Q. 65 Carry Two Marks Each.**

61. Hari (H), Gita (G), Irfan (I) and Saira (S) are siblings (i.e. brothers and sisters). All were born on 1<sup>st</sup> January. The age difference between any two successive siblings (that is born one after another) is less than 3 years. Given the following facts:

- i. Hari's age + Gita's age > Irfan's age + Saira's age
- ii. The age difference between Gita and Saira is 1 year. However, Gita is not the oldest and Saira is not the youngest.
- iii. There are no twins.

In what order were they born (oldest first)?

- (A) HSIH
  - (B) SGHI
  - (C) IGSH
  - (D) IHSG
62. 5 skilled workers can build a wall in 20 days; 8 semi – skilled workers can build a wall in 25 days; 10 unskilled workers can build a wall in 30 days. If team has 2 skilled, 6 semi-skilled and 5 unskilled workers, how long will it take to build the wall?
- (A) 20 days
  - (B) 18 days
  - (C) 16 days
  - (D) 15 days
63. Modern warfare has changed from large scale clashes of armies to suppression of civilian populations. Chemical agents that do their work silently appear to be suited to such warfare; and regretfully, there exist people in military establishments who think that chemical agents are useful tools for their cause.

Which of the following statements best sums up the meaning of the above passage;

- (A) Modern warfare has resulted in civil strife.
  - (B) Chemical agents are useful in modern warfare.
  - (C) Use of chemical agents in warfare would be undesirable.
  - (D) People in military establishments like to use chemical agents in war.
64. Given digits 2, 2, 3, 3,3, 4, 4, 4, 4 how many distinct 4 digit numbers greater than 3000 can be formed?
- (A) 50
  - (B) 51
  - (C) 52
  - (D) 54
65. If  $137 + 276 = 435$  how must is  $731 + 672$ ?
- (A) 534
  - (B) 1403
  - (C) 1623
  - (D) 1513