

B.Tech Degree III Semester Examination in Marine Engineering December 2011

MRE 306 MACHINE DRAWING

Time : 4 Hours

Maximum Marks : 100

- I. The isometric view of a machine component is given in figure. Draw the plan and elevation of the component. (20)

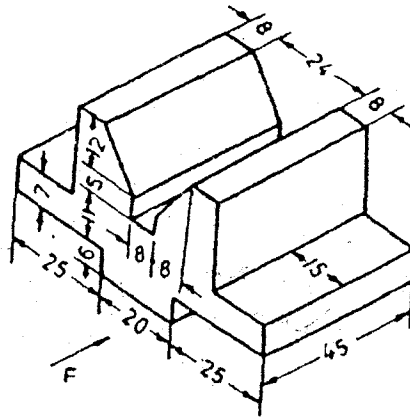

OR

- II. The isometric view of a machine component is given in figure. Draw the plan and elevation of the component. (20)

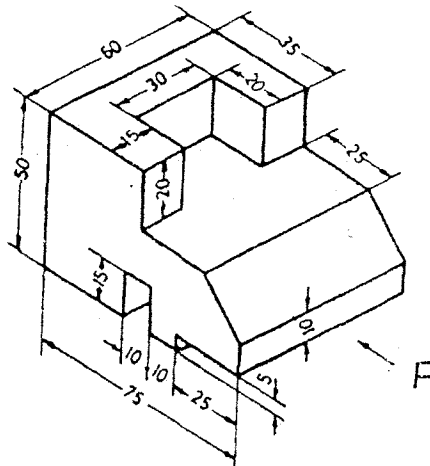

III. The isometric view of a Flanged Coupling is shown in figure. Draw the elevation with top half in section and end view. (30)

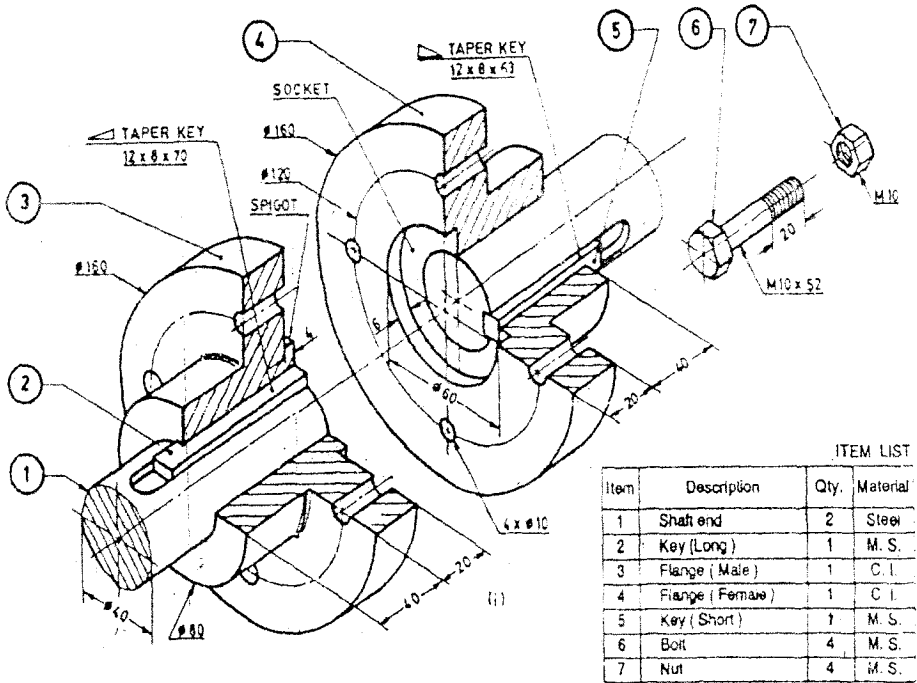

OR

IV. The isometric view of a bushed bearing is shown in figure. Draw the elevation with right half in section and full plan. (30)

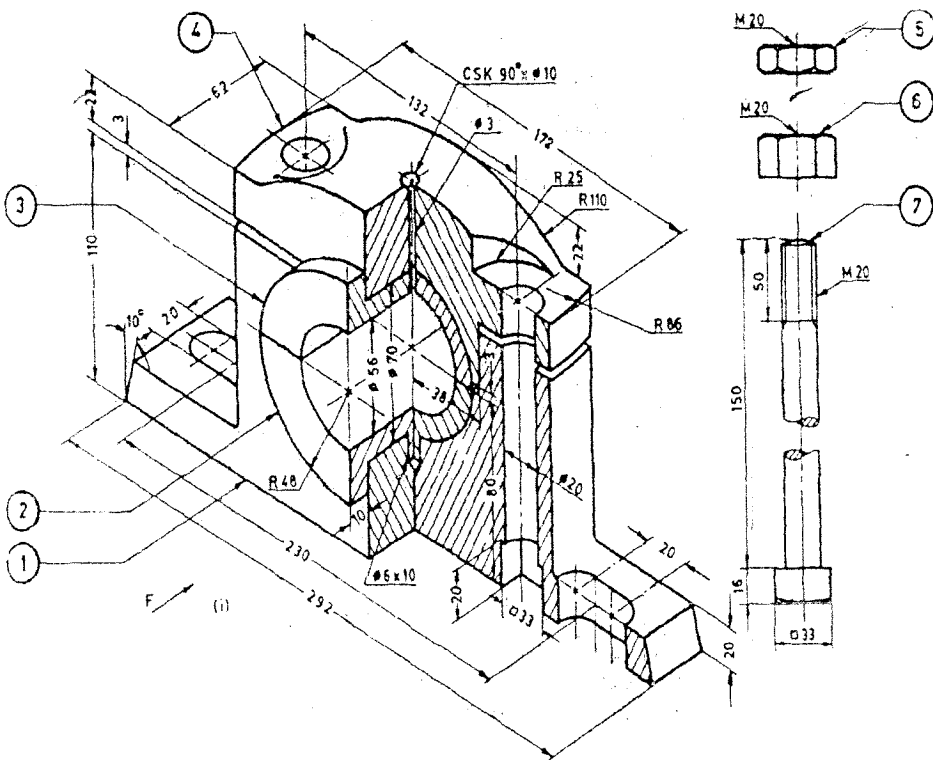

V.

The details of a Steam Stop Valve is shown in figure. Draw the elevation with right half in section and full plan.

(50)

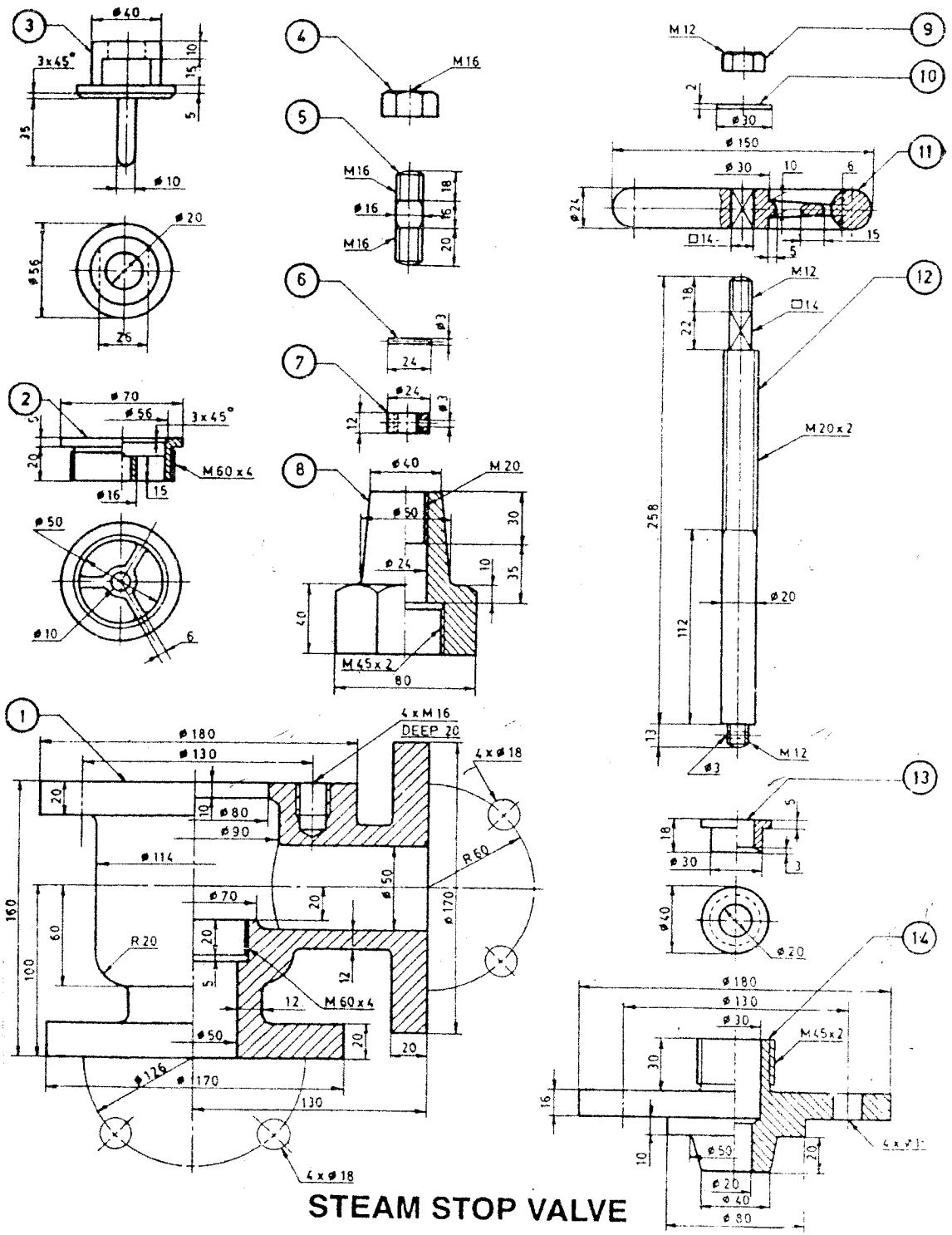

STEAM STOP VALVE

OR

(Contd.....4)

